

SWEEP

2026

SUZHOU SWEEP
ELECTRIC APPLIANCE CO.,LTD.

Tel.:0086-13812679805

E-mail: salassy@szsweep.cn

Add.: No.368, Xiecun Road, Xukou Town, Wuzhong District,
Suzhou City, Jiangsu Province, China

Company Website: www.sweep-vac.com

SWEEP



COMPANY PROFILE

We are a professional vacuum cleaner factory with BSCI & ISO 9001:2015. We have a professional research and development team that can design and manufacture vacuum cleaners. Meanwhile, we have our own laboratory and professional testing team to ensure product performance and quality. Our factory covers an area of 14,800 square meters, with six production lines and a monthly output of 200,000 pcs. All of our products have relevant certificates from a third-party laboratory. We are looking forward to cooperating with you!



THE CONTENT

About Company	01
Our Certification	03
Our Partner	04
Floor Cleaning Vacuum Cleaner	05
Cordless Vacuum Cleaner	09
Portable Vacuum Cleaner	55

ABOUT COMPANY



Quality assurance

ISO9001 standards provide guidance and tools for us who want to ensure our products and services consistently meet customer's requirement, and quality is consistently improved.



Reasonable price

Sweep's success is based on our customers' success. We believe in mutually respectful long-term relationships by providing prompt service, reasonable price and being responsive to our customers' requirements.



Punctual delivery

We owns a group of senior technicians, first-class molding and processing equipment, advanced machinery for molding plastics & hardware, and with over 500 skilled staffs efficient job, we can ensure punctual delivery.



SWEEP
Exhibition Hall



SWEEP
Laboratory



OUR CERTIFICATION

OUR PARTNER



Patent Certificate
2022



Patent Certificate
2021



Patent Certificate
2021

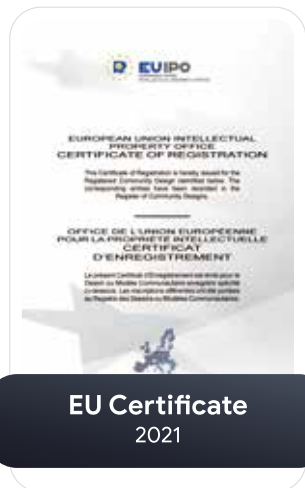

EU Certificate
2021



GS Certification
2020

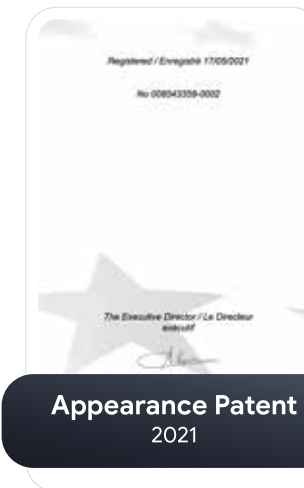

Appearance Patent
2021



PORTABLE VACUUM CLEANER

V1



28 min^(up to)
battery life



17 kPa^(up to)
vacuum



1.5 KGS
weight



Technical Parameter

Model No.	V1
Input	100-240V,50-60Hz,0.4A MAX
Output	Type C
Battery info	7.2V-4000mAh
motor power	150W (BLDC)
Charging time	3-4H
Working time	High:12mins, Low:28mins
Vacuum	High:17kPa, Low:8kPa
Air inlet filter	HEPA+stainless steel filter
Dust tank Capacity	350ml
Air Volume (m ³ /h):	55
Air Pressure (g):	70
Air Speed (m/s):	16

CORDLESS VACUUM CLEANER

V7



85 min^(up to)
battery life



31 kPa^(up to)
vacuum



650 W
motor

Technical Parameter

Model No.	V7	V7
Input	100-240V,50-60Hz,0.4A MAX	100-240V,50-60Hz,0.4A MAX
Output	27V 800mA	27V 500mA
Battery info	22.2V Li-ion 4000mAh	22.2V Li-ion 2200mAh
motor power	650W	250W
Charging time	5H	4.5H
Working time	High/Standard/Low:20/40/85 mins	High/Standard/Low:15/24/52mins
Vacuum	High/Standard/Low: 31/14/8kPa	High/Standard/Low:23/13/7kPa
Air inlet filter	Multi Cyclone+Stainless steel filter	Multi Cyclone+Stainless steel filter
Dust tank Capacity	650ml	650ml

PORTABLE VACUUM CLEANER

X3



LED Intelligent Display



35 min^(up to)
battery life



21 kPa^(up to)
vacuum



250 W
motor



reddot winner 2025

Credits

Manufacturer:
Suzhou Sweep Electric Appliance Co., Ltd., Suzhou, China



Technical Parameter

Model No.	X3
Input	110-240V,50-60Hz,0.5A MAX
Output	18V 500mA
Battery info	14.8V Li-ion 2600mAh
motor power	250W
Charging time	5.5H
Working time	High:17mins, Low:35mins
Vacuum	High: 21kPa, Low:10kPa
Air inlet filter	HEPA+stainless steel filter
Dust tank Capacity	150ml

PORTABLE VACUUM CLEANER

R7A



LED Intelligent Display



80 min^(up to)
battery life



34 kPa^(up to)
vacuum



500 W
motor



Technical Parameter

Model No.	R7A
Input	100-240V,50-60Hz,0.4A MAX
Output	36V 500mA
Battery info	28.8V Li-ion 3000mAh
motor power	500W
Charging time	6H
Working time	High/Standard/Low:25/47/80mins
Vacuum	High/Standard/Low: 34/13/8kPa
Air inlet filter	Multi Cyclone+Stainless steel filter
Dust tank Capacity	650 ml

PORTABLE VACUUM CLEANER

R7B



LED Intelligent Display



95 min^(up to)
battery life



38 kPa^(up to)
vacuum



800 W
motor



Technical Parameter

Model No.	R7B
Input	100-240V,50-60Hz,0.4A MAX
Output	30V 800mA
Battery info	25.2VLi-ion 4000mAh
motor power	800W
Charging time	5H
Working time	High/Standard/Low:23/45/95mins
Vacuum	High/Standard/Low: 38/17/8kPa
Air inlet filter	Multi Cyclone+Stainless steel filter
Dust tank Capacity	650ml

CORDLESS VACUUM CLEANER

X7A



60 min^(up to)
battery life



31 kPa^(up to)
vacuum



400 W
motor

Technical Parameter

Model No.	X7A	X7A
Input	100-240V,50-60Hz,0.4A MAX	100-240V,50-60Hz,0.4A MAX
Output	27V 500mA	36V 500mA
Battery info	22.2V Li-ion 2200mAh	29.6V Li-ion 2200mAh
motor power	300W	400W
Charging time	4.5H	4.5H
Working time	High/Standard/Low:15/30/52 mins	High/Standard/Low:17/35/60mins
Vacuum	High/Standard/Low:28/13/8kPa	High/Standard/Low:31/13/8kPa
Air inlet filter	Multi Cyclone+Stainless steel filter	Multi Cyclone+Stainless steel filter
Dust tank Capacity	650ml	650ml

CORDLESS VACUUM CLEANER

X7B



LED Intelligent Display



95 min^(up to)
battery life



34 kPa^(up to)
vacuum



500 W
motor

Technical Parameter

Model No.	X7B	X7B
Input	100-240V,50-60Hz,0.8A MAX	100-240V,50-60Hz,0.4A MAX
Output	30V 800mA	36V 500mA
Battery info	25.2V Li-ion 4000mAh	29.6V Li-ion 2200mAh
motor power	500W	500W
Charging time	5.5H	4.5H
Working time	High/Standard/Low:25/45/95 mins	High/Standard/Low:17/35/60mins
Vacuum	High/Standard/Low:34/18/8kPa	High/Standard/Low:34/13/8kPa
Air inlet filter	Multi Cyclone+Stainless steel filter	Multi Cyclone+Stainless steel filter
Dust tank Capacity	650ml	650ml

CORDLESS VACUUM CLEANER

X7C

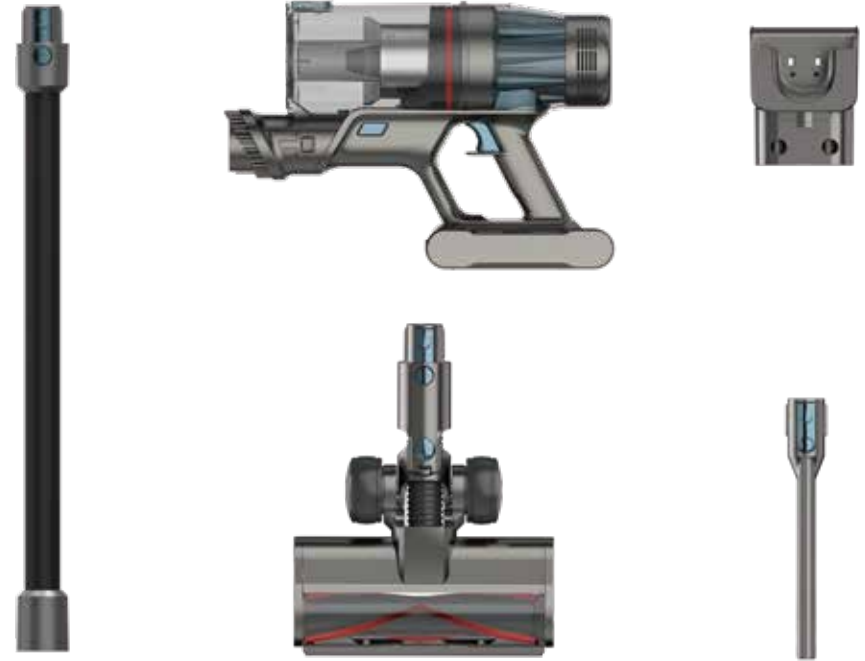

80 min^(up to)
battery life



34 kPa^(up to)
vacuum



500 W
motor

Technical Parameter

Model No.	X7C	X7C
Input	100-240V,50-60Hz,0.4A MAX	100-240V,50-60Hz,0.4A MAX
Output	36V 500mA	36V 500mA
Battery info	29.6V Li-ion 3000mAh	29.6V Li-ion 2200mAh
motor power	500W	500W
Charging time	6.5H	4.5H
Working time	High/Standard/Low:25/47/80mins	High/Standard/Low:17/35/60mins
Vacuum	High/Standard/Low:34/13/8kPa	High/Standard/Low:34/13/8kPa
Air inlet filter	Multi Cyclone+Stainless steel filter	Multi Cyclone+Stainless steel filter
Dust tank Capacity	650ml	650ml

PORTABLE VACUUM CLEANER

X7D

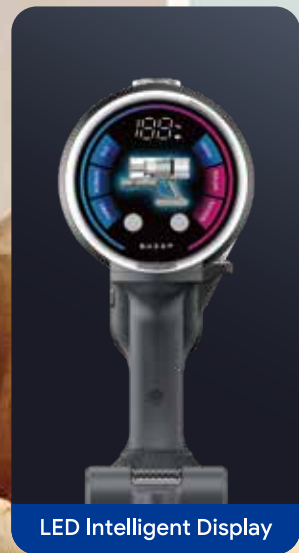

60 min^(up to)
battery life

33 kPa^(up to)
vacuum

450 W
motor

Technical Parameter

	X7D	X7D
Model No.	X7D	X7D
Input	100-240V,50-60Hz,0.5A MAX	100-240V,50-60Hz,0.4A MAX
Output	27 V 500mA	36 V 500mA
Battery info	22.2V Li-ion 2200mAh	29.6V Li-ion 2200mAh
motor power	250 W	450W
Charging time	5H	5H
Working time	High/Standard/Low: 15/25/47 mins	High/Standard/Low:17/35/60mins
Vacuum	High/Standard/Low:23/13/10kPa	High/Standard/Low:33/13/8kPa
Air inlet filter	Multi Cyclone+Stainless steel filter	Multi Cyclone+Stainless steel filter
Dust tank Capacity	650ml	650ml

CORDLESS VACUUM CLEANER

X7E



LED Intelligent Display



45 min^(up to)
battery life



22 kPa^(up to)
vacuum



250 W
motor

Technical Parameter

Model No.	X7E	X7E(BLDC)
Input	100-240V,50-60Hz,0.4A MAX	100-240V,50-60Hz,0.4A MAX
Output	27V 500mA	27V 500mA
Battery info	22.2V Li-ion 2200mAh	22.2V Li-ion 2200mAh
motor power	140W (DC)	250W
Charging time	4.5H	4.5H
Working time	High:22mins, Low:40mins	High/ Low:15 / 45mins
Vacuum	High:11kPa, Low:6kPa	High/ Low:22 / 8kPa
Air inlet filter	HEPA+stainless steel filter	Multi Cyclone+Stainless steel filter
Dust tank Capacity	500ml	650ml

PORTABLE VACUUM CLEANER

X7A Plus



60 min^(up to)
battery life



31 kPa^(up to)
vacuum



400 W
motor



Technical Parameter

Model No.	X7A Plus
Input	100-240V,50-60Hz,0.4A MAX
Output	36V 500mA
Battery info	29.6V Li-ion 2200mAh
motor power	400W
Charging time	5H
Working time	High/Standard/Low:17/35/60mins
Vacuum	High/Standard/Low:31/13/8kPa
Air inlet filter	Multi Cyclone+Stainless steel filter
Dust tank Capacity	650ml

PORTABLE VACUUM CLEANER

X7B Plus



95 min^(up to)
battery life



34 kPa^(up to)
vacuum



500 W
motor



Technical Parameter

Model No.	X7B Plus
Input	100-240V,50-60Hz,0.4A MAX
Output	30V 800mA
Battery info	25.2V Li-ion 4000mAh
motor power	500W
Charging time	5H
Working time	High/Standard/Low:25 /45 / 95 mins
Vacuum	High/Standard/Low:34/17/8kPa
Air inlet filter	Multi Cyclone+Stainless steel filter
Dust tank Capacity	650ml

PORTABLE VACUUM CLEANER

X7C Plus



80 min^(up to)
battery life



34 kPa^(up to)
vacuum



500 W
motor



Technical Parameter

Model No.	X7C Plus
Input	100-240V,50-60Hz,0.4A MAX
Output	36V 500mA
Battery info	29.6V Li-ion 3000mAh
motor power	500W
Charging time	6H
Working time	High/Standard/Low:22/40/80mins
Vacuum	High/Standard/Low: 34/14/8kPa
Air inlet filter	Multi Cyclone+Stainless steel filter
Dust tank Capacity	650ml

PORTABLE VACUUM CLEANER

R01



45 min^(up to)
battery life



22 kPa^(up to)
vacuum



200 W
motor



Technical Parameter

Model No.	R01 A	R01 B
Input	100-240V,50-60Hz,0.4A MAX	110-240V,50-60Hz,0.5A MAX
Output	27V 500mA	27V 500mA
Battery info	22.2V Li-ion 2200mAh	22.2V Li-ion 2200mAh
motor power	140W (DC)	200W (BLDC)
Charging time	4.5H	4.5H
Working time	High:22mins, Low:40mins	High:15mins, Low:45mins
Vacuum	High:11kPa, Low:6kPa	High:22kPa, Low:8kPa
Air inlet filter	HEPA+stainless steel filter	HEPA+stainless steel filter
Dust tank Capacity	500ml	500ml

PORTABLE VACUUM CLEANER

R02

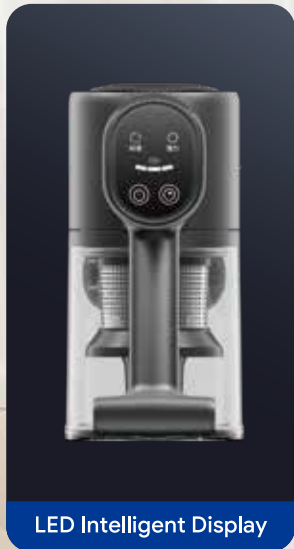

LED Intelligent Display



45 min^(up to)
battery life



11 kPa^(up to)
vacuum



140 W
motor



Technical Parameter

Model No.	R02 A	R02 B
Input	100-240V,50-60Hz,0.4A MAX	110-240V,50-60Hz,0.5A MAX
Output	27V 500mA	27V 500mA
Battery info	22.2V Li-ion 2200mAh	22.2V Li-ion 2200mAh
motor power	140W	200W (BLDC)
Charging time	4.5H	4.5H
Working time	High:22mins, Low:45mins	High:15mins, Low:45mins
Vacuum	High:11 kPa, Low:6kPa	High:22 kPa, Low:8kPa
Air inlet filter	Multi Cyclone+Stainless steel filter	HEPA+stainless steel filter
Dust tank Capacity	500ml	500ml

PORTABLE VACUUM CLEANER

R3



85 min^(up to)
battery life



31 kPa^(up to)
vacuum



450 W
motor



Technical Parameter

Model No.	R3
Input	100-240V,50-60Hz,0.4A MAX
Output	30V 800mA
Battery info	21.6V Li-ion 4000mAh
motor power	450W
Charging time	5H
Working time	High/Standard/Low:25/45/85mins
Vacuum	High/Standard/Low: 31 /13 /8kPa
Air inlet filter	Multi Cyclone+Stainless steel filter
Dust tank Capacity	650 ml

FLOOR CLEANING VACUUM CLEANER

M1



UI Display



13 kPa^(up to)
vacuum



230 W
MAX



50 min^(up to)
battery life

M3

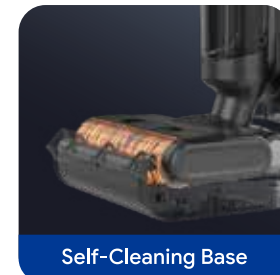

Self-Cleaning Base



LED Intelligent Display

Technical Parameter

	M1	M3
Model No	M1	M3
Input	100-240V,50-60Hz,0.5A MAX	100-240V, 0-60Hz0.5A MAX
Output	27V 500mA	36V 500mA
Battery info	21.6V Li ion 2600mAh	28.8V Liion 2600mAh
motor power	180W	High:230W,Standard:120W
Charging time	5.5h	5.5h
Workong time	High: 15min, Low: 25min	High:22min,Standard:50min
Vacuum	High: 6kPa , Low: 4kPa	High: 13kPa,Low: 7kPa
CWT Capacity	630ml	630ml
DWT Capacity	500ml	500ml

FLOOR CLEANING VACUUM CLEANER

M7



6 kPa^(up to)
vacuum



23 min^(up to)
battery life



180 W
MAX



Self-Cleaning Base



LED Intelligent Display

Technical Parameter

Model No	M7
Input	100-240V,50-60Hz,0.5A MAX
Output	27V 500mA
Battery info	21.6V Li ion 2600mAh
motor power	180W
Charging time	5.5h
Workong time	High: 15min, Low: 25min
Vacuum	High: 6kPa, Low: 4kPa
CWT Capacity	630ml
DWT Capacity	500ml

CORDLESS VACUUM CLEANER

X5 Ultra



LED Intelligent Display



V-Shaped Roller Brush



Stainless Steel Filter

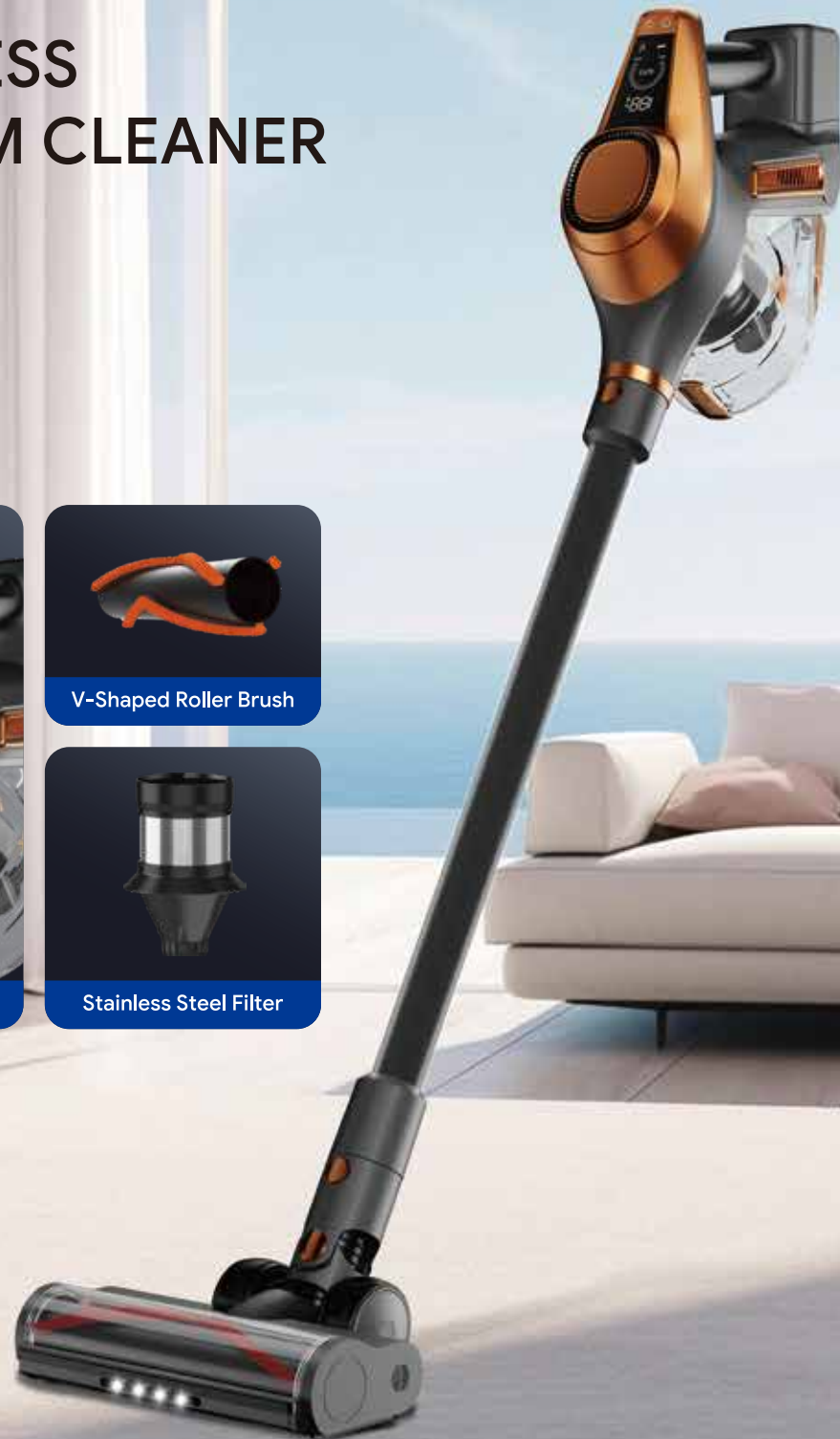

55 min^(up to)
battery life



31 kPa^(up to)
vacuum



450 W
motor

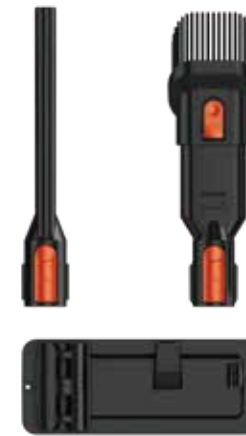

Technical Parameter

Model No.	X5 Ultra
Input	100-240V,50-60Hz,0.4A MAX
Output	36V 500mA
Battery info	29.6V Li-ion 2200mAh
motor power	450W
Charging time	4.5H
Working time	High/Standard/Low:17/33/55 mins
Vacuum	High/Standard/Low:31/14/8kPa
Air inlet filter	Multi Cyclone+Stainless steel filter
Dust tank Capacity	800ml

CORDLESS VACUUM CLEANER

X5 Pro



LED Intelligent Display



V-Shaped Roller Brush



Stainless Steel Filter

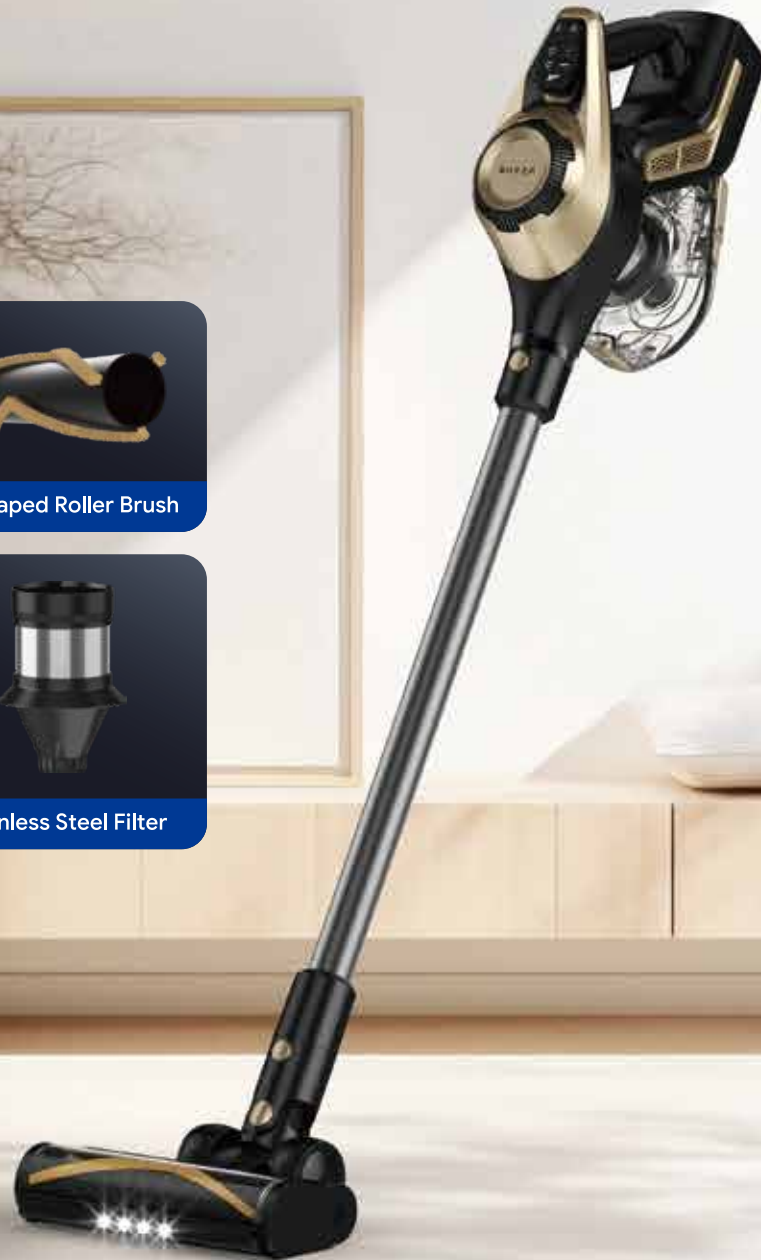

45 min^(up to)
battery life



23 kPa^(up to)
vacuum



250 W
motor



Technical Parameter

Model No.	X5 Pro 140W	X5 Pro 250W
Input	100-240V,50-60Hz,0.4A MAX	100-240V,50-60Hz,0.4A MAX
Output	27V 500mA	27V 500mA
Battery info	22.2V Li-ion 2200mAh	22.2V Li-ion 2200mAh
motor power	140W(DC)	250W
Charging time	4.5H	4.5H
Working time	High/Low:20/40mins	High/ Low:15/45 mins
Vacuum	High/ Low:11/7kPa	High/ Low:23/8kPa
Air inlet filter	HEPA +Stainless steel filter	HEPA +Stainless steel filter
Dust tank Capacity	800ml	800ml

CORDED VACUUM CLEANER

X5 AC



Stainless Steel Filter



Powerful Motor



LED Lights



15 kPa^(up to)
vacuum



500 W
motor



Technical Parameter

Model No.	X5 AC
Input	100-240V,50-60Hz
motor power	500W
Vacuum	15kPa
Air inlet filter	HEPA +Stainless steel filter
Dust tank Capacity	800ml

CORDLESS VACUUM CLEANER

P11 PRO MAX

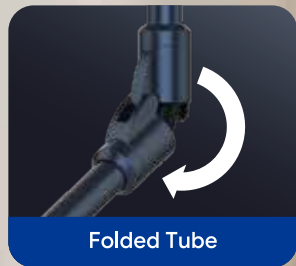

Folded Tube



LED Intelligent Display



60 min^(up to)
battery life



31 kPa^(up to)
vacuum



400 W
motor



Technical Parameter

Model No.	P11 PRO MAX
Input	100-240V,50-60Hz,0.4A MAX
Output	36V 500mA
Battery info	29.6V Li-ion 2200mAh
motor power	400W
Charging time	4.5H
Working time	High/Standard/Low:12/22 /60mins
Vacuum	High/Standard/Low:31/18/8kPa
Air inlet filter	Multi Cyclone+Stainless steel filter
Dust tank Capacity	500ml

CORDLESS VACUUM CLEANER

P13



LED Intelligent Display



V-Shaped Roller Brush



Multi-Cyclone Filtration



Metal Telescoping Tube

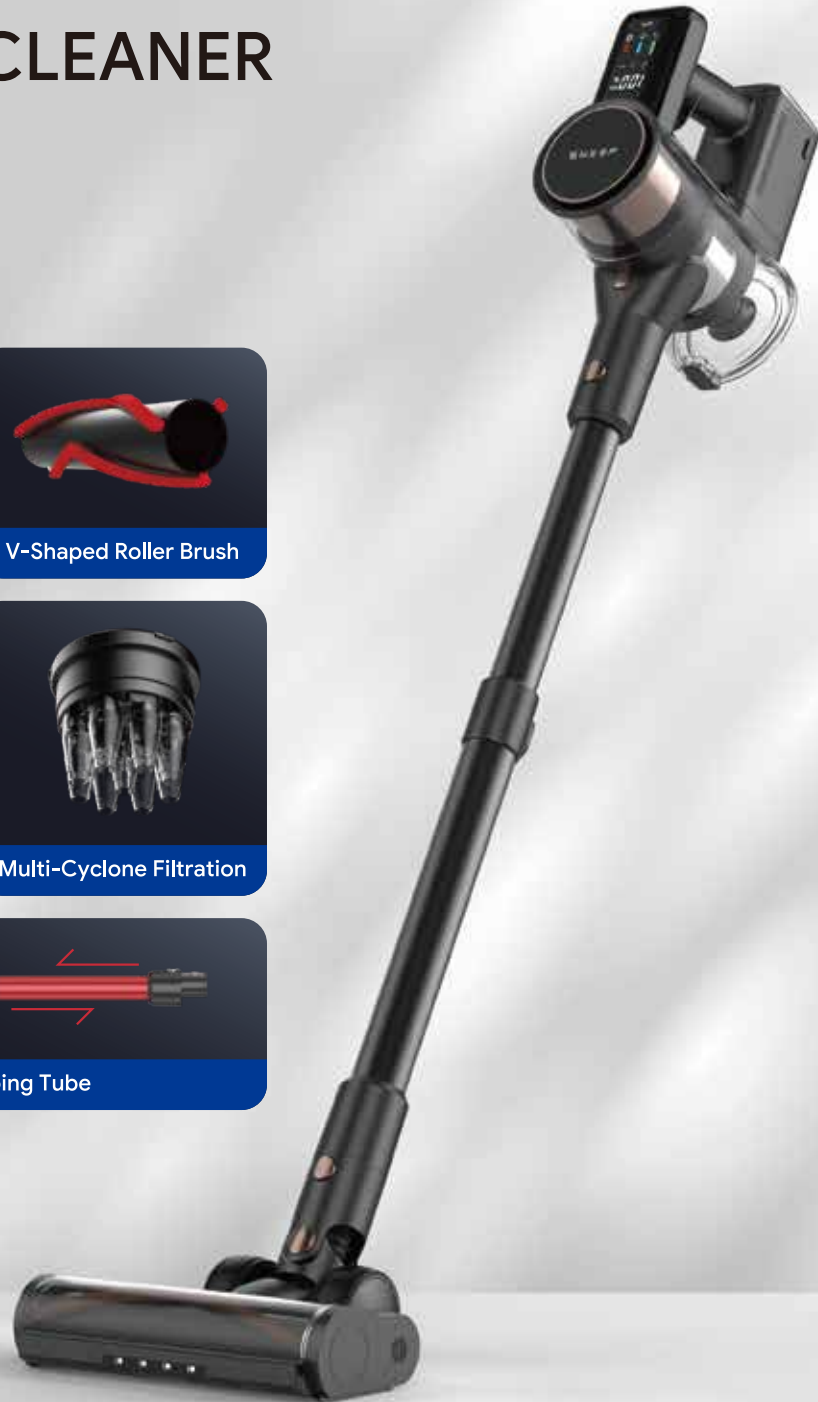

60 min^(up to)
battery life



31 kPa^(up to)
vacuum



400 W
motor



Technical Parameter

Model No.	P13
Input	100-240V,50-60Hz,0.4A MAX
Output	36V 500mA
Battery info	29.6V Li-ion 2200mAh
motor power	400W
Charging time	4.5H
Working time	High/Standard/Low:12/22/60mins
Vacuum	High/Standard/Low:31/18/8kPa
Air inlet filter	Multi Cyclone+Stainless steel filter
Dust tank Capacity	500ml

PORTABLE VACUUM CLEANER

XP1



Working Status Indicator



Charging Storage



One-click To Dump Dust



35 min^(up to)
battery life



20 kPa^(up to)
vacuum



200 W
motor



Technical Parameter

	XP1-A	XP1-B
Model No.	XP1-A	XP1-B
Input	100-240V,50-60Hz,0.4A MAX	100-240V,50-60Hz,0.4A MAX
Output	18V 500mA	23V 500mA
Battery info	14.8V Li-ion 2200mAh	18.5V Li-ion 2200mAh
motor power	160W BLDC motor	200W BLDC motor
Charging time	4.5H	4.5H
Working time	High:12mins/Low:30mins	High:14mins/Low:35mins
Vacuum	High:18kPa/Low:8kPa	High:20kPa/Low:8kPa
Air inlet filter	Multi Cyclone+Stainless steel filter	Multi Cyclone+Stainless steel filter
Dust tank Capacity	300ml	300ml

CORDLESS VACUUM CLEANER

S5



55 min^(up to)
battery life



30 kPa^(up to)
vacuum



400 W
motor

Technical Parameter

	S5 A	S5 B
Model No.	S5 A	S5 B
Input	100-240V,50-60Hz,0.4A MAX	100-240V,50-60Hz,0.4A MAX
Output	30V 500mA	30V 500mA
Battery info	25.9V Li-ion 2200mAh	25.9V Li-ion 2200mAh
motor power	300W	400W
Charging time	4.5H	4.5H
Working time	High/Standard/Low:15/25/45 mins	High/Standard/Low:13/25/55 mins
Vacuum	High/Standard/Low:27/13/8kPa	High/Standard/Low:30/18/10kPa
Air inlet filter	Multi Cyclone+Stainless steel filter	Multi Cyclone+Stainless steel filter
Dust tank Capacity	500ml	500ml

CORDLESS VACUUM CLEANER

P11



40 min^(up to)
battery life



20 kPa^(up to)
vacuum



250 W
motor



Technical Parameter

Model No.	P11
Input	100-240V,50-60Hz,0.4A MAX
Output	27V 500mA
Battery info	22.2V Li-ion 2200mAh
motor power	250 W
Charging time	4.5H
Working time	High/ Low:15/40mins
Vacuum	High/ Low:20/8kPa
Air inlet filter	HEPA+Stainless steel filter
Dust tank Capacity	500ml

CORDLESS VACUUM CLEANER

S7A



35 min^(up to)
battery life



20 kPa^(up to)
vacuum



200 W
motor



Technical Parameter

	S7A	S7B
Model No.	S7A	S7B
Input	100-240V,50-60Hz,0.4A MAX	100-240V,50-60Hz,0.4A MAX
Output	27V 500mA	27V 500mA
Battery info	22.2V Li-ion 2200mAh	22.2V Li-ion 2200mAh
motor power	140W(DC)	200W
Charging time	4.5H	4.5H
Working time	High/ Low: 18 / 40mins	High/ Low: 12/ 35 mins
Vacuum	High/ Low: 11/ 6kPa	High/ Low: 20/ 10kPa
Air inlet filter	HEPA +Stainless steel filter	HEPA +Stainless steel filter
Dust tank Capacity	500ml	500ml

CORDLESS VACUUM CLEANER

S7C



55 min^(up to)
battery life



24 kPa^(up to)
vacuum



300 W
motor



Technical Parameter

Model No.	S7C
Input	100-240V,50-60Hz,0.4A MAX
Output	30V 500mA
Battery info	25.9V Li-ion 2200mAh
motor power	300W
Charging time	4.5H
Working time	High/Standard/Low:16/30/55mins
Vacuum	High/Standard/Low:24/12/7kPa
Air inlet filter	HEPA+Stainless steel filter
Dust tank Capacity	500ml

CORDLESS VACUUM CLEANER

SP-003



Multi-layer Filtering



Electric Roller Brush



LED Intelligent Display



35 min^(up to)
battery life



19 kPa^(up to)
vacuum



200 W
motor



Technical Parameter

	SP-003 E	SP-003 D
Model No.	SP-003 E	SP-003 D
Input	100-240V,50-60Hz,0.4A MAX	100-240V,50-60Hz,0.4A MAX
Output	27V 500mA	27V 500mA
Battery info	22.2V Li-ion 2200mAh	22.2V Li-ion 2200mAh
motor power	140W (DC)	200W
Charging time	4.5H	4.5H
Working time	High:22mins, Low:40mins	High:13mins, Low:35mins
Vacuum	High:11kPa, Low:6kPa	High:19kPa, Low:10kPa
Air inlet filter	HEPA+stainless steel filter	HEPA+stainless steel filter
Dust tank Capacity	500ml	500ml

CORDLESS VACUUM CLEANER

SP-002



35 min^(up to)
battery life



20 kPa^(up to)
vacuum



200 W
motor



Technical Parameter

	SP-002 A	SP-002 B
Model No.	SP-002 A	SP-002 B
Input	100-240V,50-60Hz,0.4A MAX	100-240V,50-60Hz,0.4A MAX
Output	27V 500mA	27V 500mA
Battery info	22.2V Li-ion 2200mAh	22.2V Li-ion 2200mAh
motor power	120W (DC)	200W
Charging time	4.5H	4.5H
Working time	High:18mins, Low:35mins	High:12mins, Low:35mins
Vacuum	High:11kPa, Low:7kPa	High:20kPa, Low:10kPa
Air inlet filter	HEPA+stainless steel filter	HEPA+stainless steel filter
Dust tank Capacity	500ml	500ml

PORTABLE VACUUM CLEANER

SP-001



Charging Base



2 in 1 Brush



Stainless Steel Filter



35 min^(up to)
battery life



14 kPa^(up to)
vacuum



0.82 KGS
weight



Technical Parameter

	SP-001 A	SP-001 B
Model No.	SP-001 A	SP-001 B
Input	100-240V,50-60Hz,0.4A MAX	100-240V,50-60Hz,0.4A MAX
Output	14V 500mA	18V 500mA
Battery info	11.1V Li-ion 2600mAh	14.8V Li-ion 2600mAh
motor power	90W (BLDC)	120W (BLDC)
Charging time	5.5H	5.5H
Working time	High:18mins, Low:25mins	High:18mins, Low:35mins
Vacuum	High:12kPa, Low:8kPa	High:14kPa, Low:8kPa
Air inlet filter	HEPA+stainless steel filter	HEPA+stainless steel filter
Dust tank Capacity	100ml	100ml

PORTABLE VACUUM CLEANER

S6



BLDC Motor



Charging Base



Stainless Steel Filter



35 min^(up to)
battery life



15 kPa^(up to)
vacuum



0.82 KGS
weight

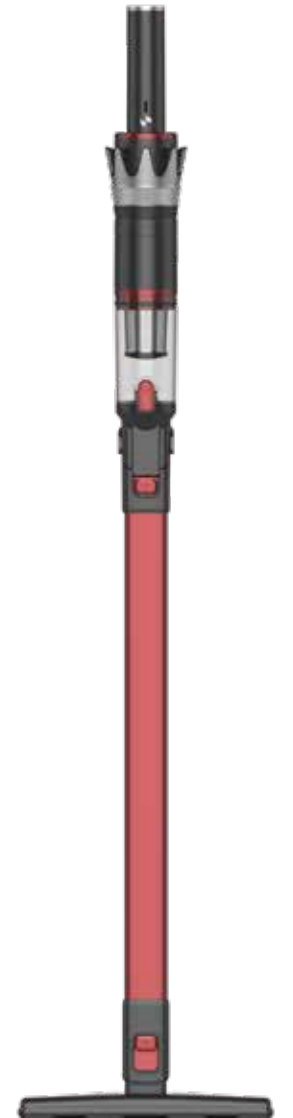

Technical Parameter

	S6 A	S6 B
Model No.	S6 A	S6 B
Input	100-240V,50-60Hz,0.4A MAX	100-240V,50-60Hz,0.4A MAX
Output	14V 500mA	18V 500mA
Battery info	11.1V Li-ion 2600mAh	14.8V Li-ion 2600mAh
motor power	90W	120W
Charging time	5.5H	5.5H
Working time	High:18mins, Low:35mins	High:19mins, Low:35mins
Vacuum	High:12kPa, Low:9kPa	High:15kPa, Low:9kPa
Air inlet filter	HEPA+stainless steel filter	HEPA+stainless steel filter
Dust tank Capacity	100ml	100ml

PORTABLE VACUUM CLEANER

S8



15 min (up to)
battery life



11 kPa (up to)
vacuum



0.45 KGS
weight

Technical Parameter

	S8 A	S8 B
Model No.	S8 A	S8 B
Input	100-240V,50-60Hz,0.4A MAX	100-240V,50-60Hz,0.4A MAX
Output	5V 2A Type C	5V 2A Type C
Battery info	7.4V Li-ion 2600mAh	7.4V Li-ion 2600mAh
motor power	65W (DC)	65W
Charging time	5.5H	5.5H
Working time	15mins	20mins
Vacuum	5kPa	11 kPa
Air inlet filter	HEPA+stainless steel filter	HEPA+stainless steel filter
Dust tank Capacity	80ml	80ml

Floor brush series



Charging station



Optional accessories

