

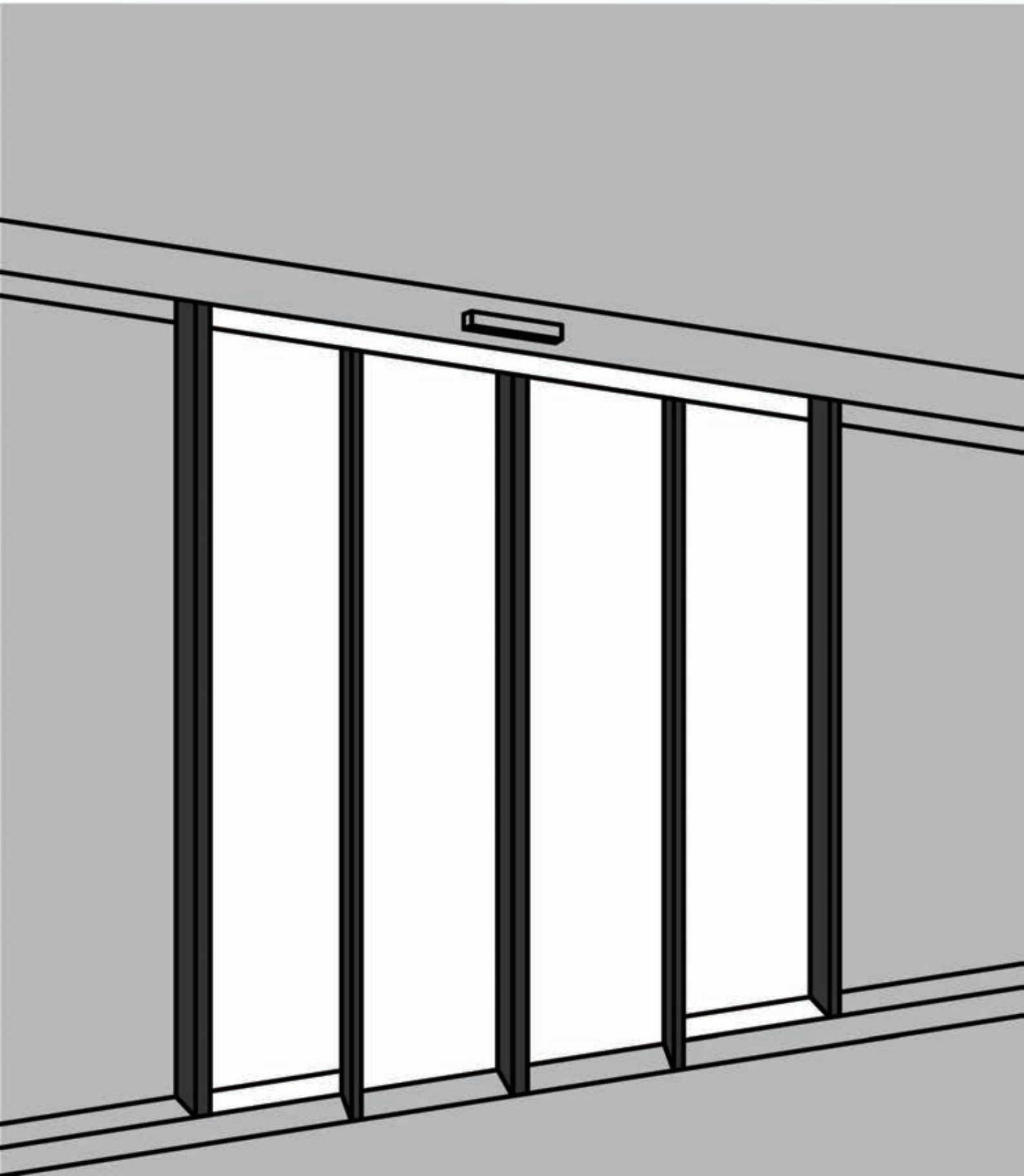

Installation Manual

Telescopic door





- Installation of automatic door should be entrusted to the appointed distributor or professional installation personnel, or it may be dangerous.
 - Installation must be performed by professional installation personnel according to local law.
 - This manual must be kept well for maintenance.
-

Contents

1、 Safety Precautions	1-2
2、 Components of mechanism	3-5
3、 Sectional view of track and cover	4
4、 Components List	5
5、 Installation process	6
6、 Product features and technical specifications.....	7
7、 Installation of hanger.....	8
8、 Installation of hanger and stopper.....	9
9、 Installation and adjustment of door leaf.....	10
10、 Installation of trackA and track B	11
11、 Installation and adjustment of door leaf.....	12
12、 Installation of belt fix plate	13
13、 Installation of motor,controller and idler pulley.....	14
14、 Installation of belt link plate	15
15、 Installation of belt connector	16
16、 Adjustment of idler pulley(long belt).....	17
17、 Belt length table	17
18、 Adjustment of idler pulley(short belt).....	18
19、 Installation of sensor.....	19
20、 Installation of door leaf guide	19
21、 Connection of motor.....	20
22、 Learning cycle setting.....	20
23、 Connection of sensor.....	21-22
24、 Connection of access keypad	23
25、 Connection of inter-lock and photocell	24
26、 Connection of UPS and electronic lock	25
27、 Connection of function keypad.....	26
28、 Date setting	27
29、 Trouble shooting	28-30

Safety Precautions

- The contents and categories a user must abide by are presented and described by the following graphic expressions.



Warning

Misoperation may cause injury even death to the operator.



Caution

Misoperation may cause injury or physical loss to the operator.



This stands for the contents prohibited.



This stands for compulsory contents.



Warning

- Installation and adjustment must be carried out according to the Installation Manual. Carelessness in installation and adjustment will lead to such accidents as fire, electric shocks or fall off.
- During the installation never allow the pedestrians to pass through the automatic door or approach the work site. Because any tools or parts falling off during the installation will cause injury to the pedestrians.
- Never remodel the parts, otherwise fire, electric shocks or fall will occur.
- Never use the power beyond the stipulated voltage or frequency, otherwise fire or electric shocks will occur.
- The sensor should be set and adjusted to make sure that the opening area of the door will fully fall into the range of sensor detection without any blind area. If the detecting range is too small or having blind area, the pedestrians will be collided or squeezed by the door, causing injury.
- Do fix up photocell to ensure the detecting range for the walking area of the door leaf, otherwise the pedestrians will be collided or squeezed by the door leaf, causing injury.

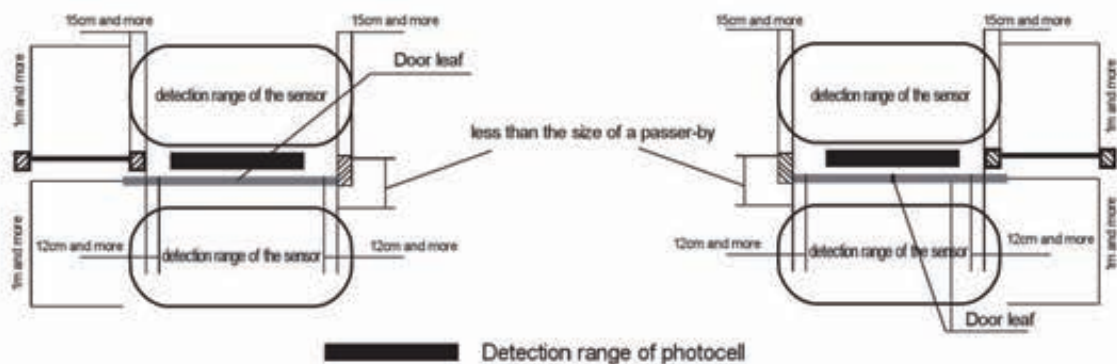





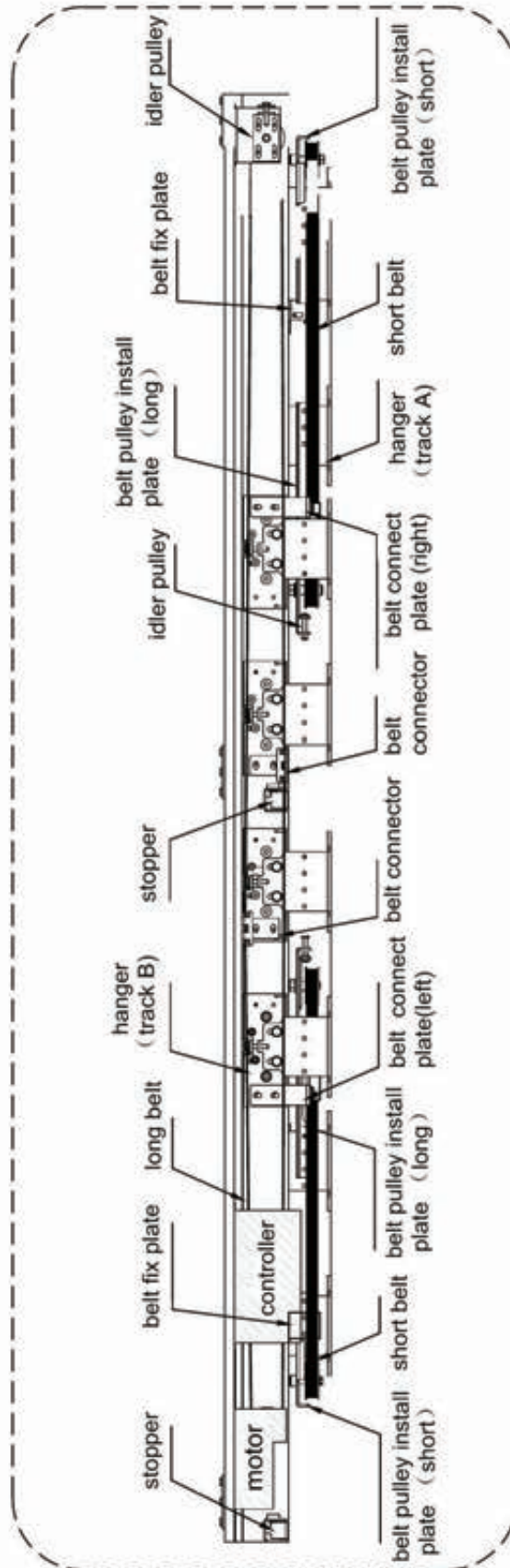



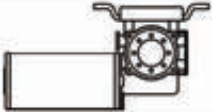

Components of mechanism

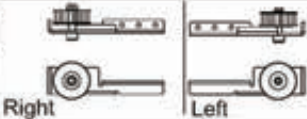
● Name of components

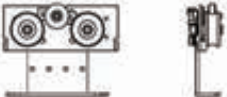

Components of mechanism

● Components list

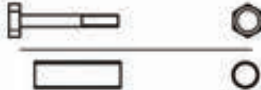
Description	Schematic diagram	Quantity
Motor		1
Controller		1
Belt pulley install plate (short)		2 (left,right)
Stopper		2
Hanger		8
belt pulley install plate (long)		2 (Left,right)
Belt		1 (20M)
Idler pulley		1
Belt connector		2
belt fix plate		2
belt connect plate		2 (Left,right)
Screw		3 SET
Attachment	Installation manual /Certificate of Approval / Product quality certification	1 SET

Product features

- Microprocessor control technology and advanced mechanical manufacture.
- Self-learning when power on, this function is selectable by user.
- Manual adjustment, easy to adjust.
- Opening and closing smoothly, low noise.
- Brushless DC motor, long working life and low noise (less than 40dp).
- Inter-lock: support multiple access control systems. Bounce after meeting resistance when close or open .
- Humanized control function for electronic lock.

Technical specifications

Specifications	Telescopic door	
Door leaf mode	Double-opening	
Door leaf weight	Max 4*120kg	
Door leaf width	DW=450-1450mm	
Voltage	AC 90-240V, 50-60Hz	
Opening speed	20-55cm/s (Adjustable)	
Closing speed	20-55cm/s (Adjustable)	
Opening time	0-20second (Adjustable)	
Manual open force	<40N	<50N
Motor	24V, 100W brushless DC motor	
Operating temperature	-20℃ ~ +70℃	

Installation of hanger

● Hanger installation

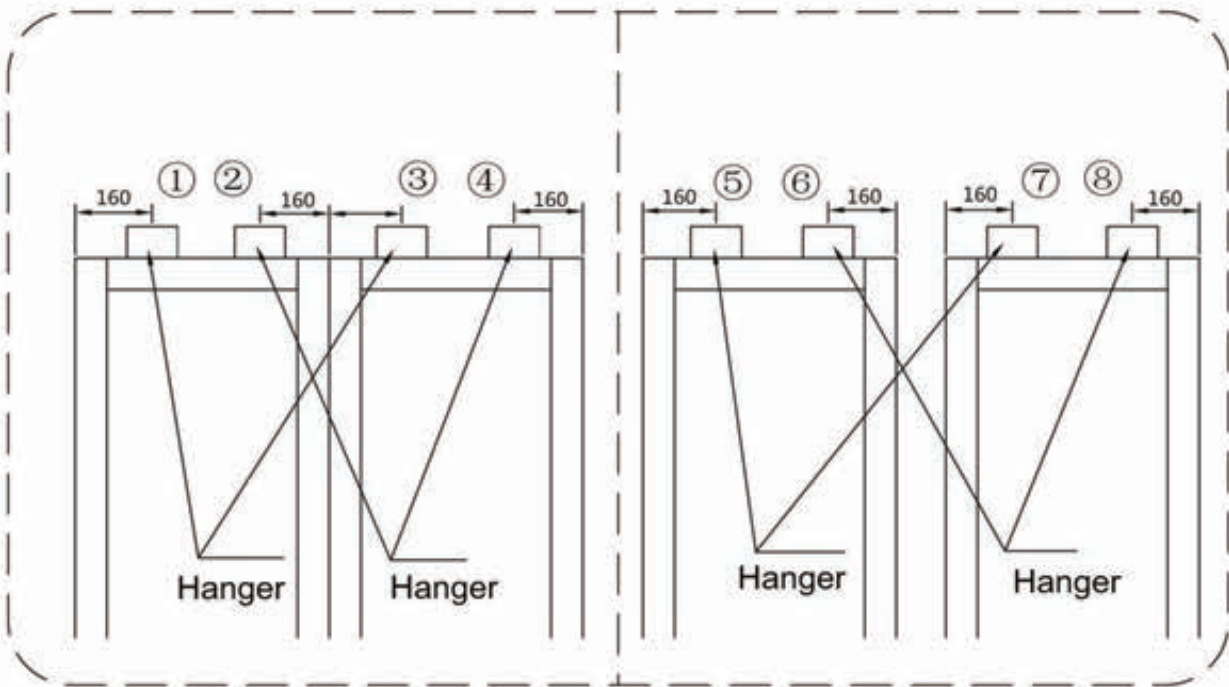

Caution

- (1) In installation, the pulley center of the hanger should be in full parallel with the door leaf. If not, the service life of the pulley will be shortened.
- (2) Please don't collide track and its inner parts. Otherwise, it will cause failure to parts, shorter service life to pulley and noise, etc

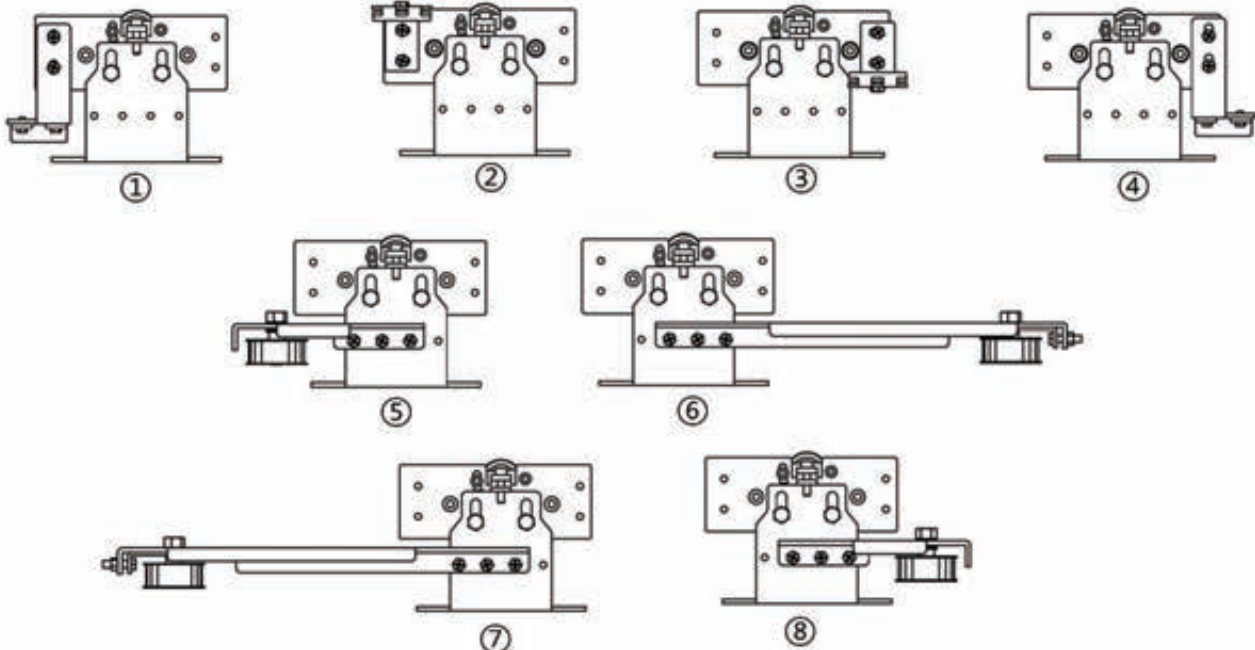

Installation and adjustment of door leaves

● Installation of track A door leaf

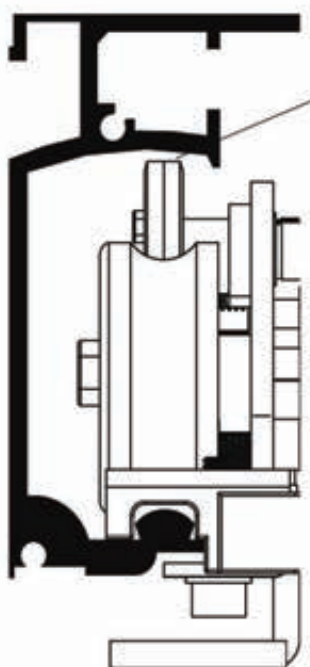
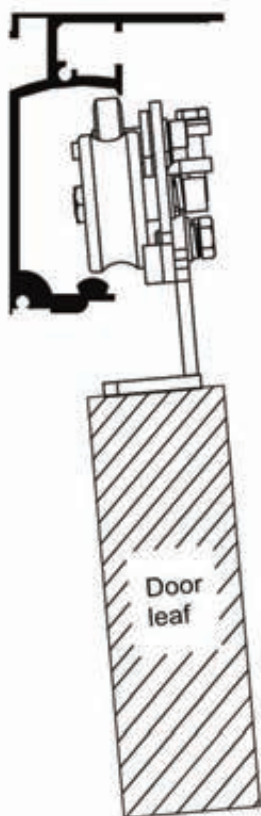

the gap between anti-drop wheel and the top of the track keep 0.5mm (according to the actual adjustment)

As is shown in the left figure, if the door leaf can't be installed horizontally, it can be tilted for installation

- 1、Lassen anti-drop wheel to make the anti-drop wheel at the lowest position.
- 2、Connect door leaf with hanger.
- 3、Door leaf is tilted by 5°-10° to make the hanger can be smoothly embedded within the track.
- 4、Check the gap at the top of the track at 0.5mm (according to the actual adjustment), then tighten the screw on the anti-drop Wheel.
- 5、Confirm the friction during the operation.

If the door leaf is hard to move, the following items should be checked to solve the problem:

- (1) The hanger is mounted vertically on the door leaf.
- (2) Any friction between the anti-drop wheel and the top of the track.
- (3) Any friction between the door leaf and frame.
- (4) Any friction between the hanger and anti-drop device, any friction between the hanger and the rail.

Anti-drop device

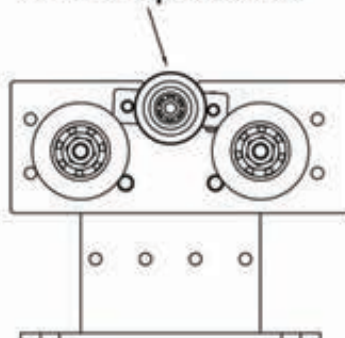

Screw A

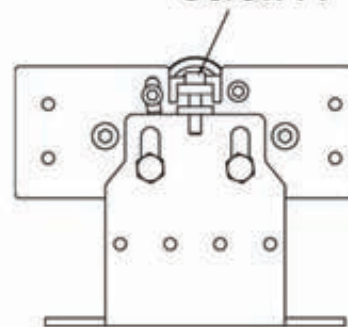

Installation of track A and track B

1. place two track according to figure (pay attention keep both side in a straight line) .
2. fix plate on the top of track with screw.
3. Put Sleeves between two track, fix with screw B and tighten nut.
4. Repeat from step 1 to step 3 at the middle of track & another end of track.

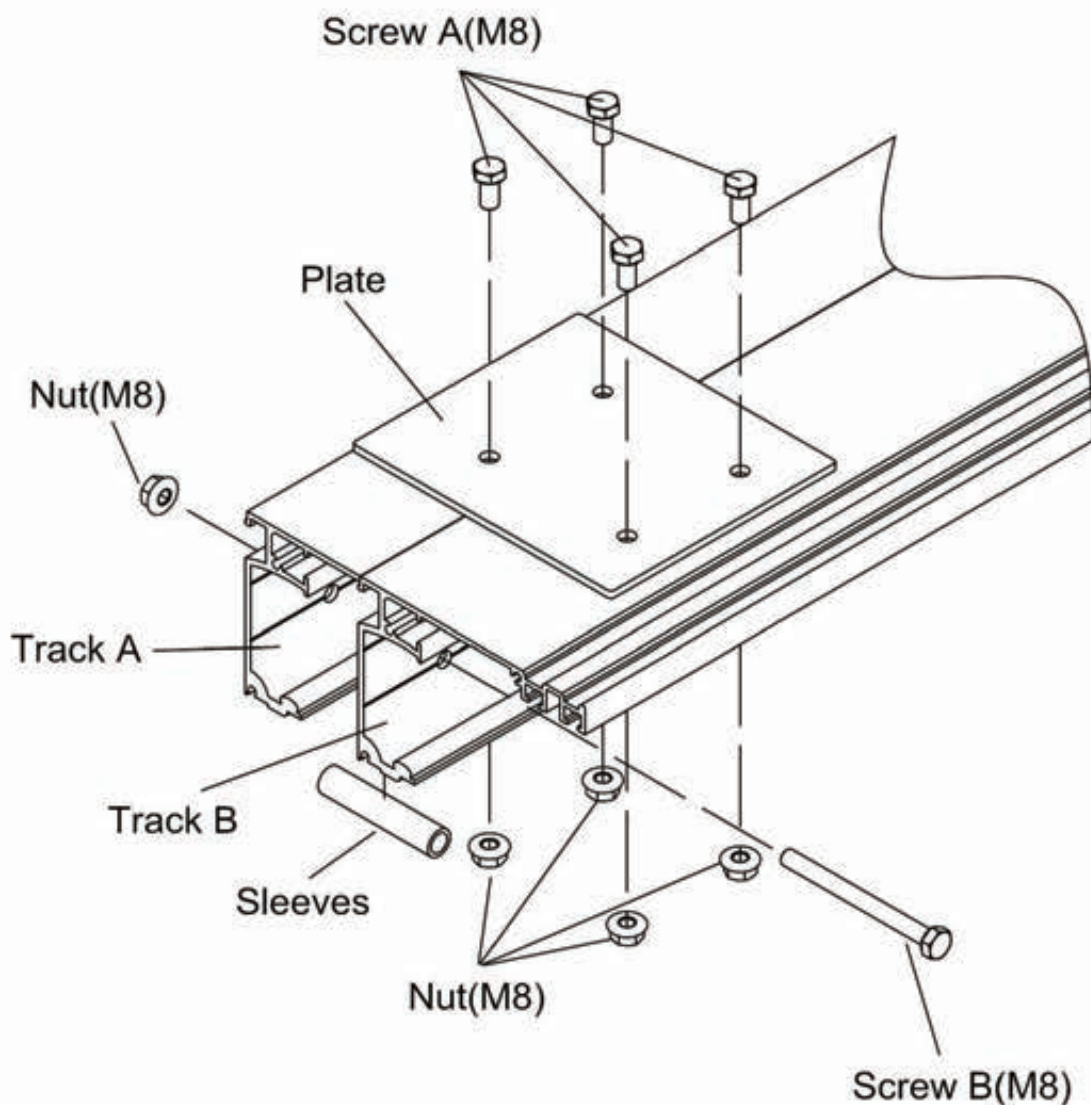

installation and adjustment of door leaves

● Installation of track A door leaf

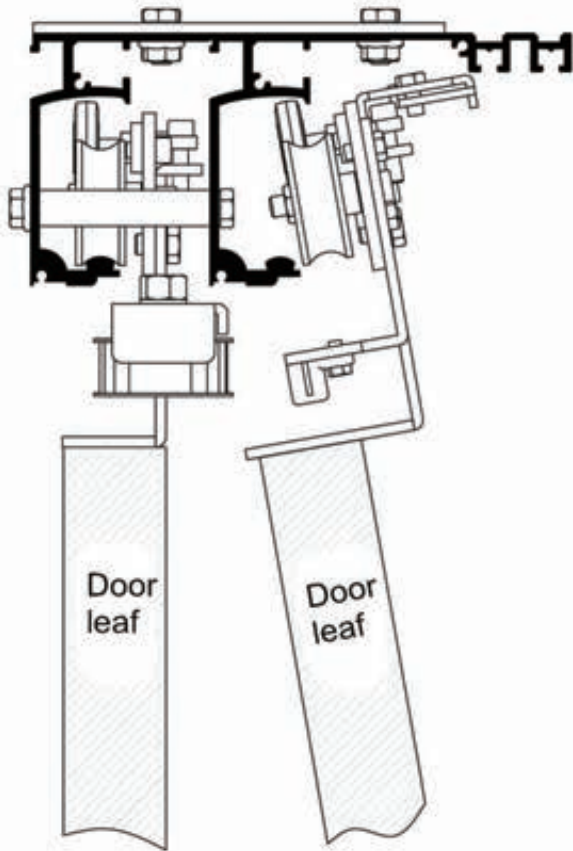

As is shown in the left figure, if the door leaf can't be installed horizontally, it can be tilted for installation

- 1、Losen anti-drop wheel to make the anti-drop wheel at the lowest position.
- 2、Connect door leaf with hanger.
- 3、Door leaf is tilted by 5° - 10° to make the hanger can be smoothly embedded within the track.
- 4、Check the gap at the top of the track at 0.5mm (according to the actual adjustment), then tighten the screw on the anti-drop Wheel.
- 5、Confirm the friction during the operation.

If the door leaf is hard to move, the following items should be checked to solve the problem:

- (1) The hanger is mounted vertically on the door leaf.
- (2) Any friction between the anti-drop wheel and the top of the track.
- (3) Any friction between the door leaf and frame.
- (4) Any friction between the hanger and anti-drop device, any friction between the hanger and the rail.

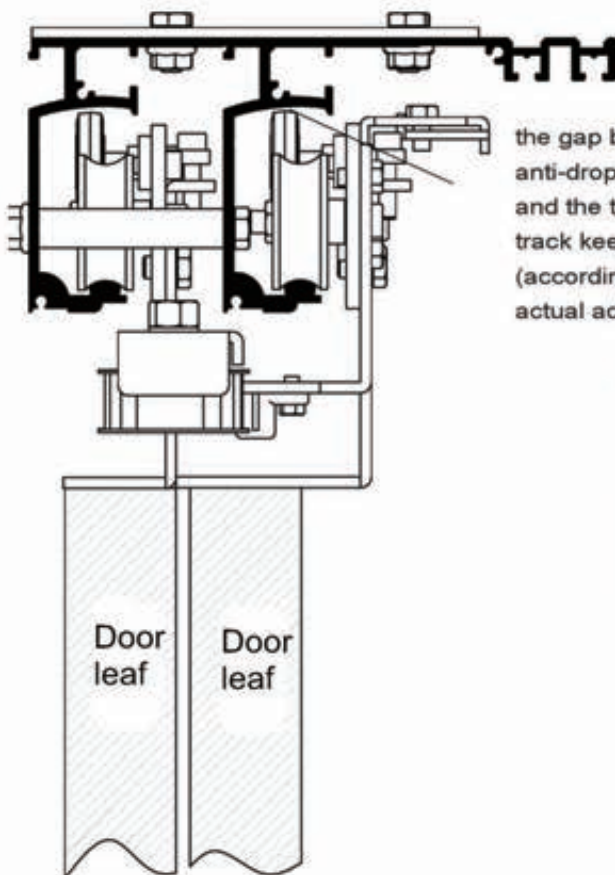

the gap between anti-drop wheel and the top of the track keep 0.5mm (according to the actual adjustment)

Anti-drop device

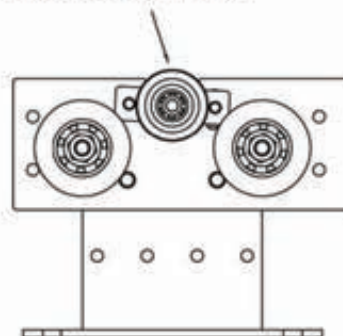

Screw A

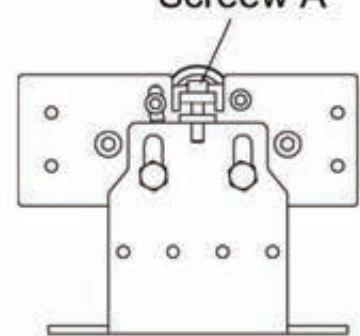

Installation of belt fix plate

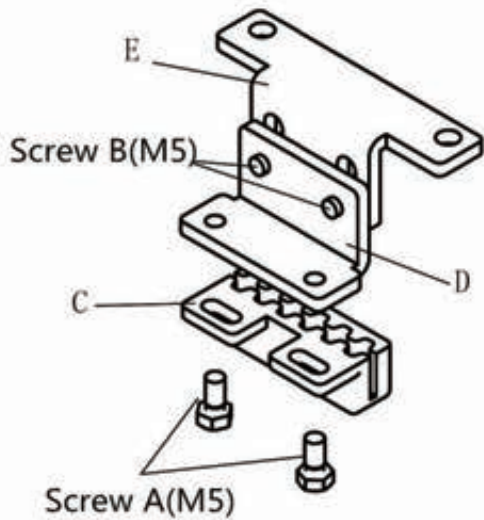

1. Remove the screw A , take off the C.
2. Cut the belt according to the belt cutting.
3. Hang belt to belt wheel of each side.
4. Adjust the short belt tension with reference to the adjustment of the belt tension.
5. Tighten screw A, make the C and B fixed together.
6. Put the E as shown in the figure , keep belt horizontally.
7. fix The E onto track (Attention : The position of belt install plate should not affect door operation) .

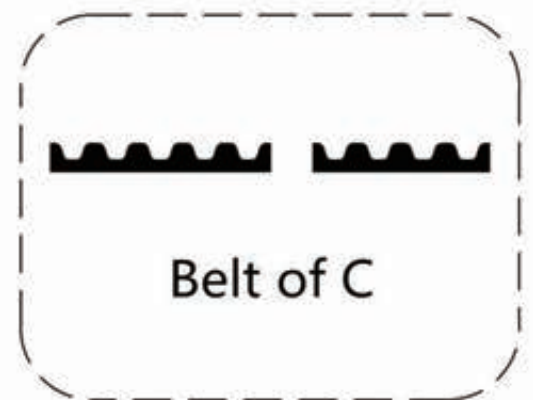
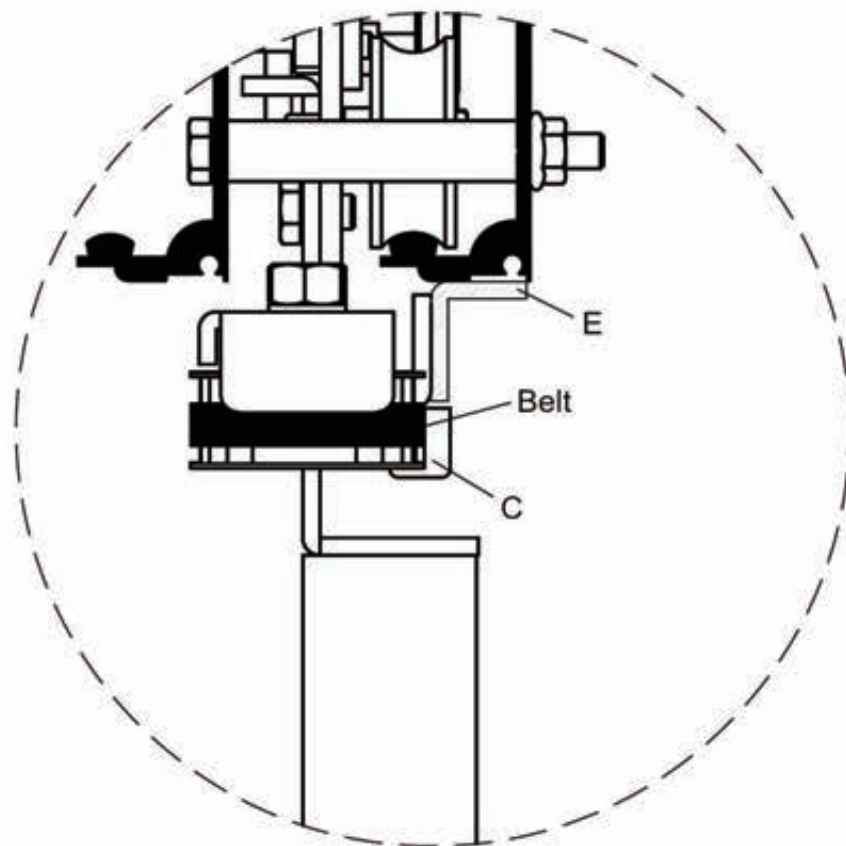

Installation of motor

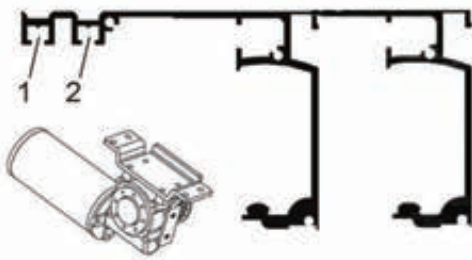

1. Put respectively four square screws in grooves number 1 and 2 before installing the motor.
2. According to the graphical position fasten the motor on the track by four square screw. Then put spring washer and tighten mounting nuts.

Caution: Driving wheel on the motor must deflect towards the inside of the track.

installation of controller

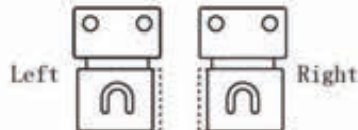
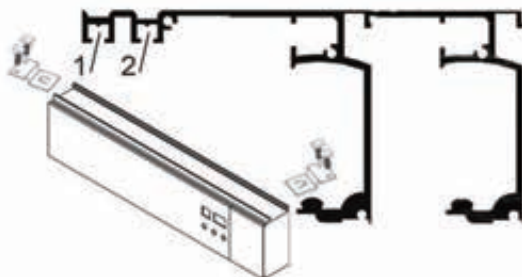

1. Put respectively four square screws in grooves number 1 and 2 before installing the controller.
2. Connect the controller fittings with four square screws, Place spring washers and slightly tighten nuts.
3. Buckle the controller main body into the controller fittings, to a suitable location, and tighten the mounting nut.

Caution : There is the difference between right and left for the controller fittings. please confirm as the graphic logo.

Installation of idler pulley

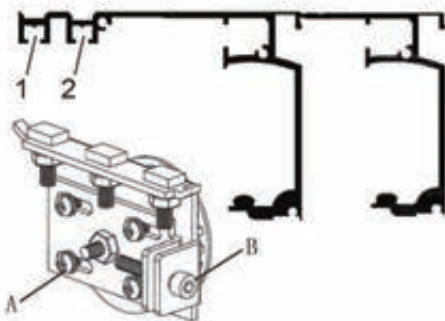

1. Put three square screws in groove number 2 before installing the idler pulley. (If place in groove number 1 groove, the driving wheels on the pulley and motor are not in a straight line ,which will cause wear and distortion for belt, and even cause the belt fall off.)
2. Connect the pulley main body with three square screws, Place spring washers and slightly tighten nuts.
3. Lossen four screws like A and socket head screw B.
4. Place the belt on the driving wheels of the motor and the pulley .Adjust the position of the pulley's three square screws on the track, then tighten.

Installation of belt connect plate

● Installation of belt connect plate A

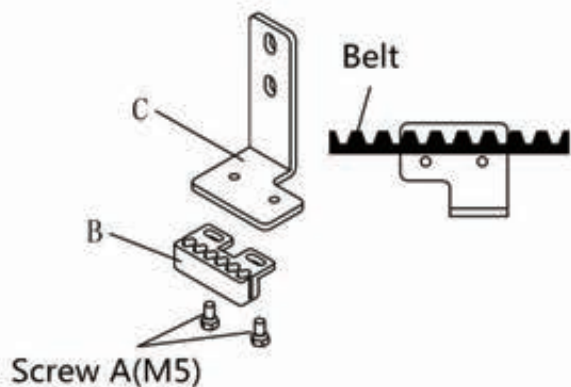

1. Loosen the screw A and remove The B.
2. Move two outer door leaf to close position.
3. Adjust position of inner door leaf, make the overlap distance of inner door and outer door among 3-5CM (at same side).
4. Belt let into B according to the position of C.
5. Fix B to C by tighten screw A.

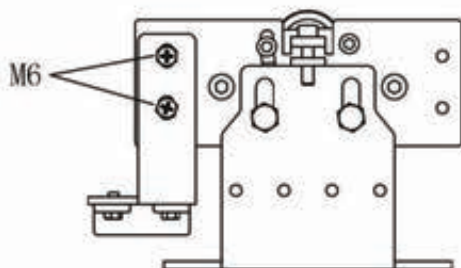

● Installation of belt connect plate B

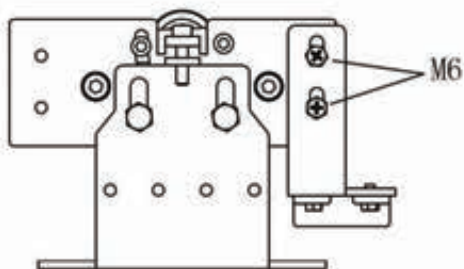
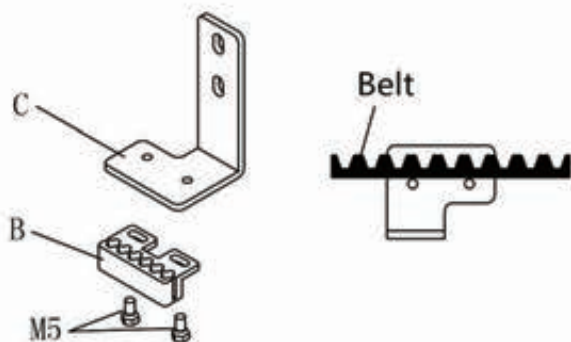

Belt installation of double opening

● Installation of belt connector A(1-6)

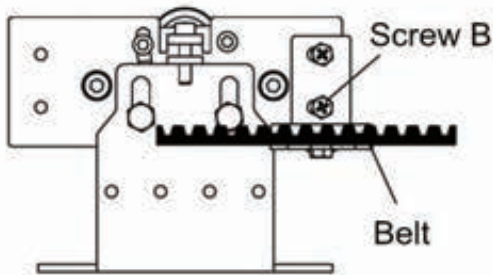
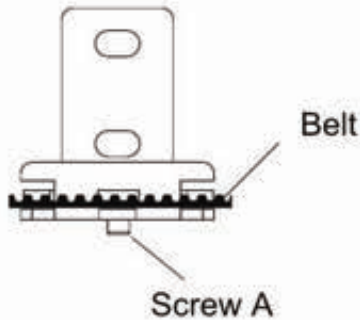

● Installation of belt connector A(7-11)

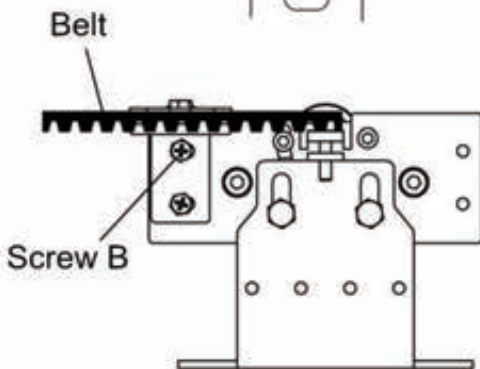
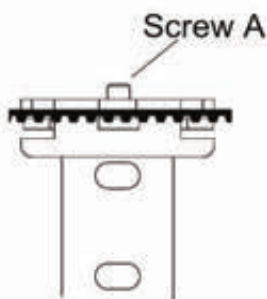

1. Remove the screwA and loosen the belt connectorA.
2. Cut the belt according to the belt cutting table.
3. Both ends of the belt are put into the fastening part from the center of the fastening part.
4. Fix the fastening part to the belt connector part.
5. Hang the belt to the belt wheel on the side of the motor, then hang up to the pulley.
6. Tighten screw B and fix the belt connectorA to the hanger.
7. Adjust the belt tension with reference to the adjustment of the belt tension.
8. Makes the two doors really in the closed position.
9. Remove the screwA and loosen the belt connectorB.
10. Install belt device to belt, then fix with screwA.
11. Tighten screw B after adjusting the position of the door.
12. Tighten screw B after adjusting the position of the door.

Belt in the belt connector A

Belt in the belt connector B

Adjustment of idler pulley

1. Loosen the four fastening screw and adjusting screw to make the adjustment plate in the far right (adjustable range of the tention increase).
2. Put belt into the driving wheel of the motor on one side and into driving wheel of the pulley on the other side. Adjust the three square screws. Make the belt tight as far as possible, then tighten the three nuts to fix pulley
3. Turn the adjusting screw clockwise with socket head (M5) so that the adjusting plate will be moved to the right and the belt tension increased gradually. Adjusting the belt tension to tighten four fasening screw suitably.

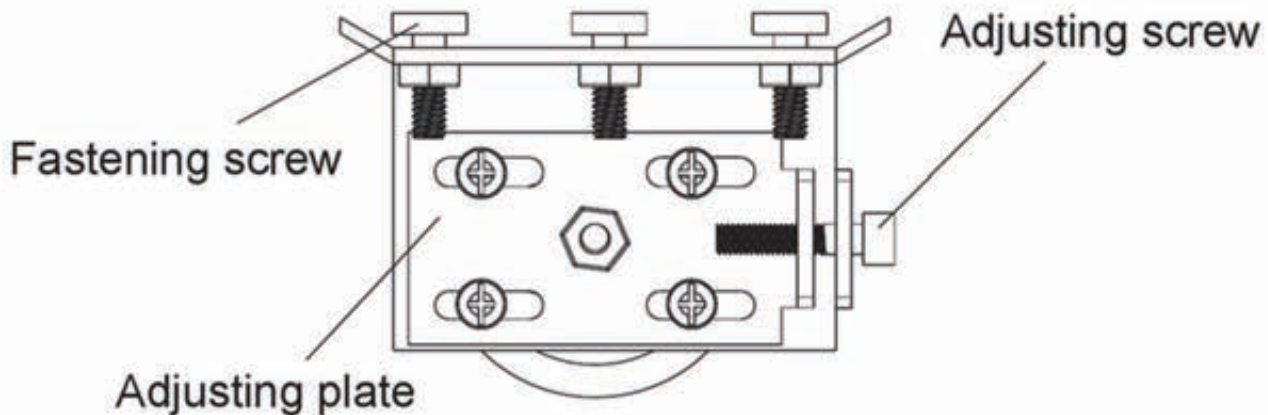

Adjustment of idler pulley (short belt)

1. Loosen fastening nuts and adjusting nut to make adjusting plate in the far left (adjustable range of the tension increase) .
2. Put one side of belt into the driving wheel of the tightening device ,another side put into the driving wheel of another hanger.
3. Turn the adjusting nut clockwise with Six angle wrench (10mm) , so that the adjusting plate will be moved to the right and the belt tension increased gradually. Adjusting the belt tension to tighten r fastening nut suitably.

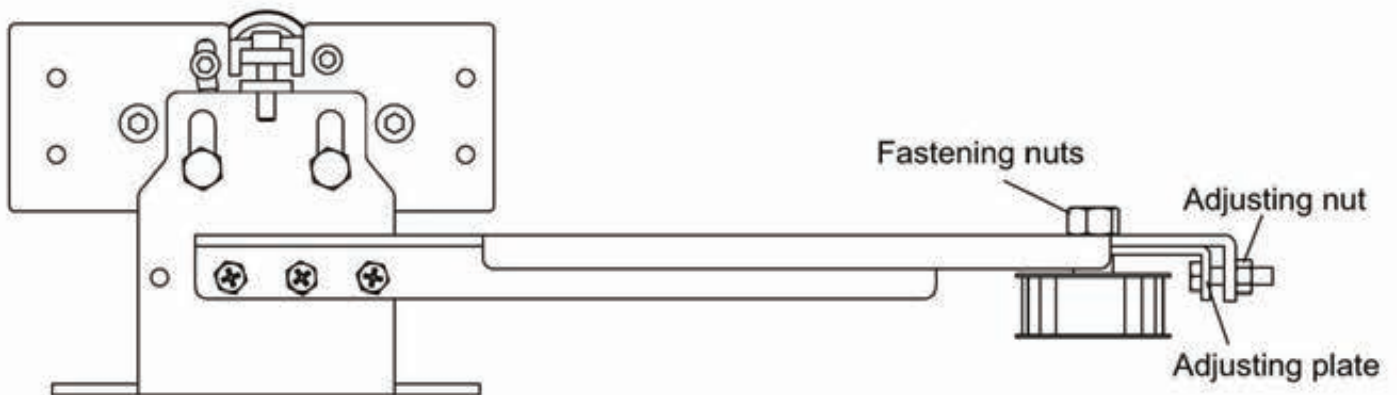

Installation of sensor

The sensor should be installed at the center of the door leaf.

The max installing height of sensor is 3m. If more than 3 m,

Please configure special sensor. Generally, install on both indoor and outdoor separately.

Please refer to the circuit diagram when wiring. More detailed installation details

please refer to the installation manual of our company.

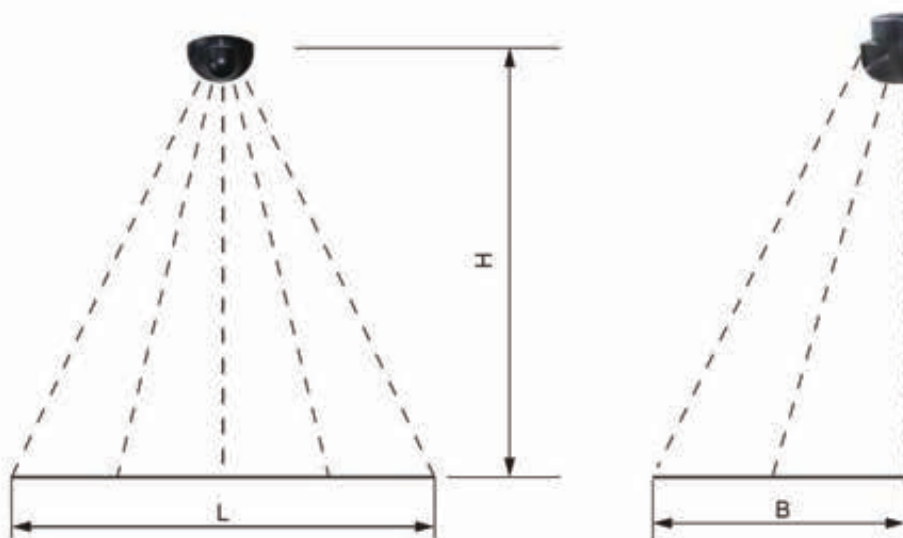

Caution: Sensor terminal voltage of different manufacturers, different types varies, don't literally change.

Installation of door leaf guider

- Two types of door leaf guider:

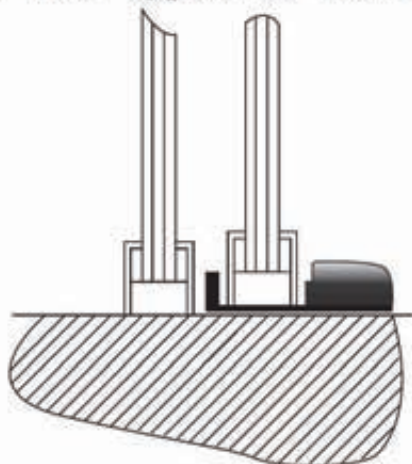

Suitable for framed door

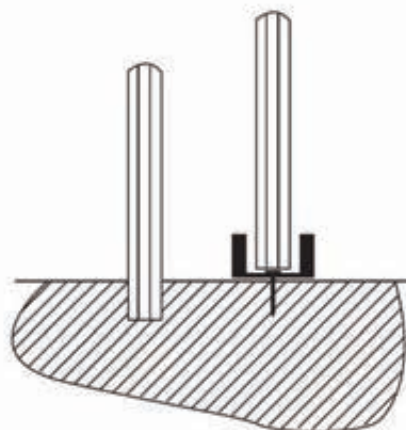

Suitable for frameless door

- 1. Door leaf guide should be installed in the center of the movable door leaf .
Axis coincides with the center line of the door leaf
- 2. Center distance between two door leaf guides must be less than the total width of two door leaves : $2DW$

Connection of motor, controller and power switch

Connection of motor, controller and power switch

Caution: All the connection should be finished under the power off status.

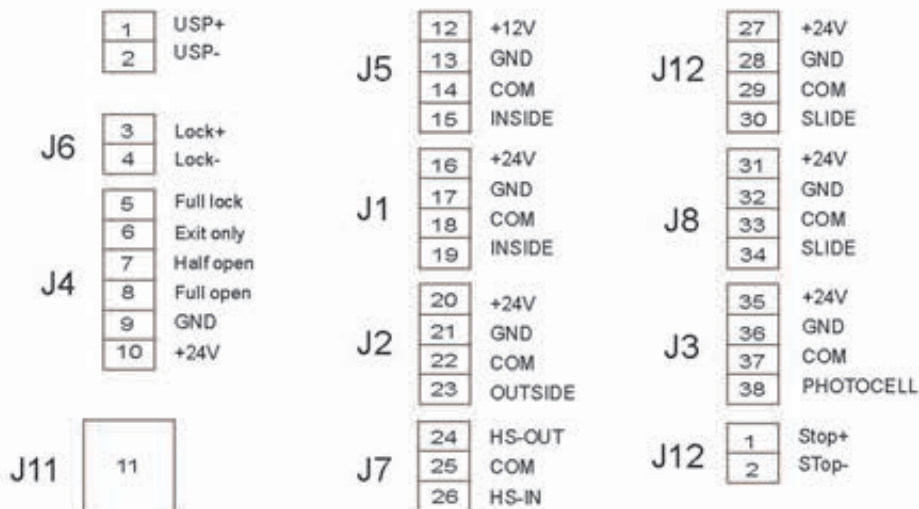
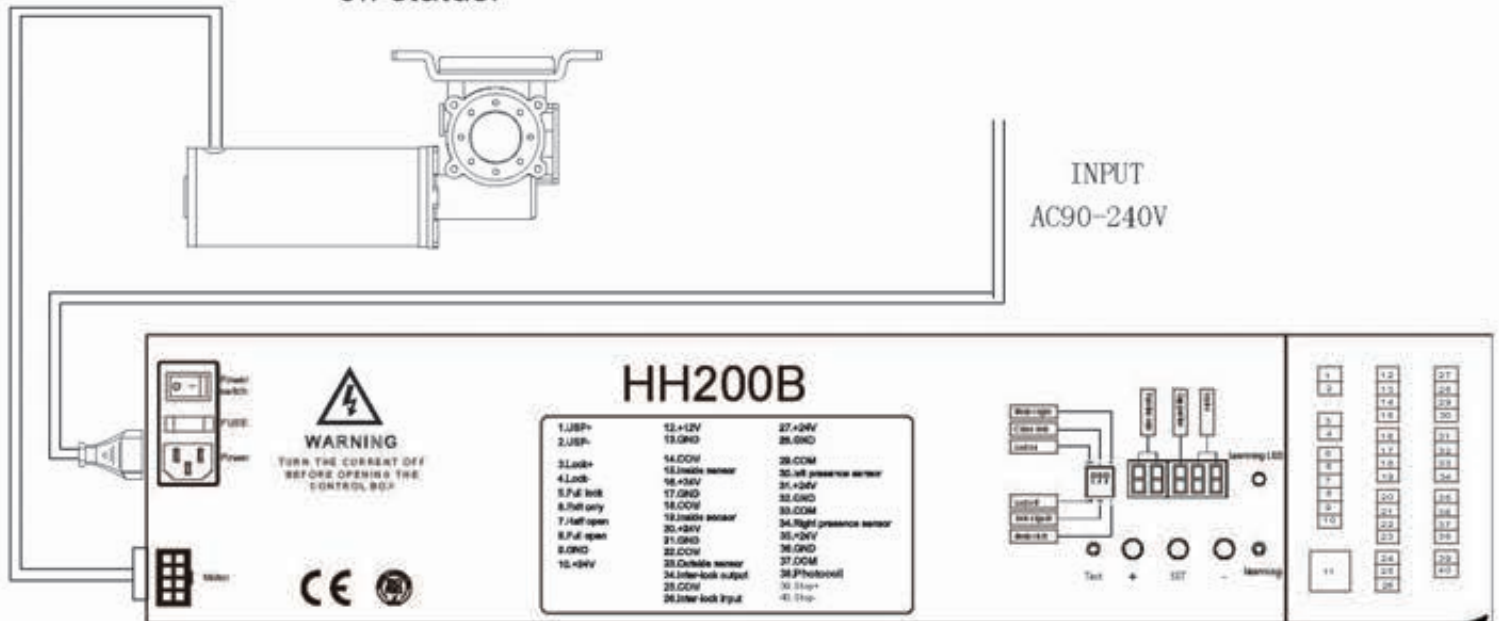

Learning cycle setting

At first time using, power on, the door will do self-learning. After first learn cycle, the controller will record the working cycle.

If you want to do self-learning cycle again, please do following steps.

1. When power is off, press the TEST key.
2. Then power on, press the TEST key always 3 second. then the led will show the number '12121'.
3. The door start learning cycle.

Connection of sensor

Caution: All the connection should be conducted under the power off status.

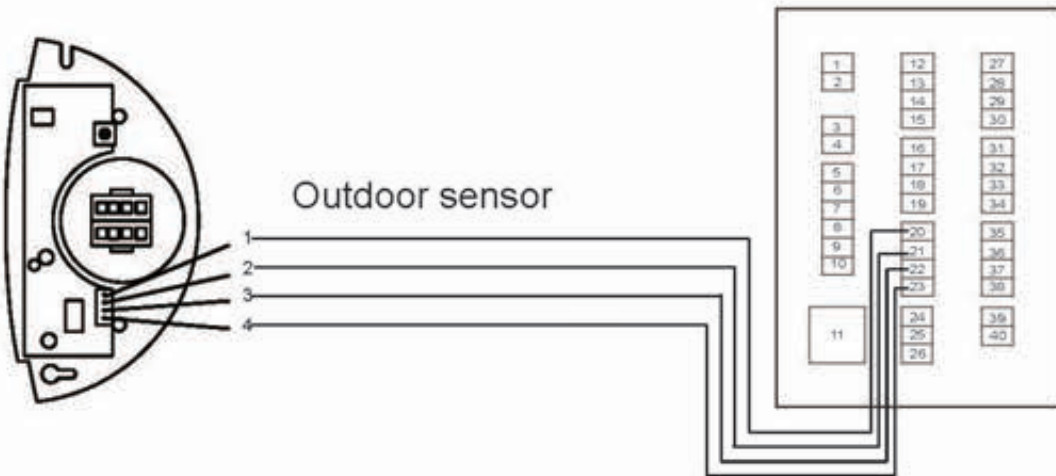
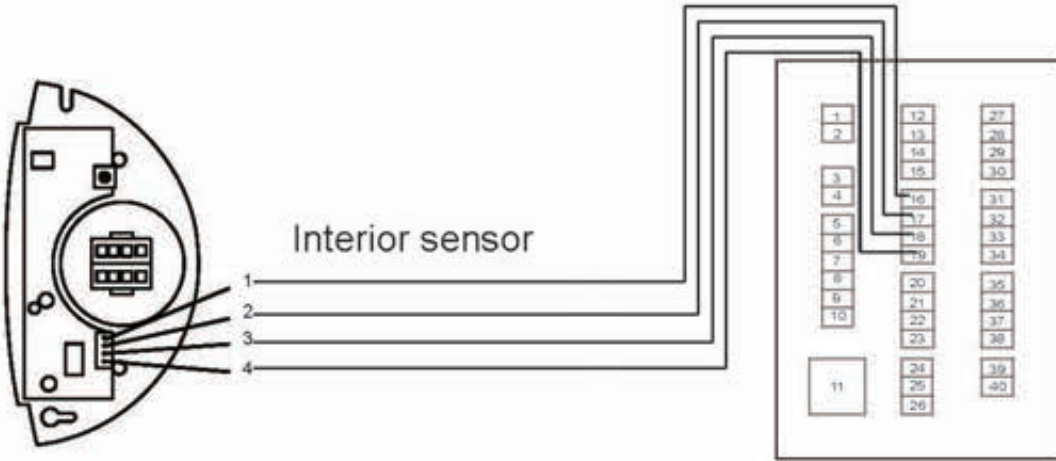

1.Brown 2.Green 3.White 4.Yellow

Connection of sensor

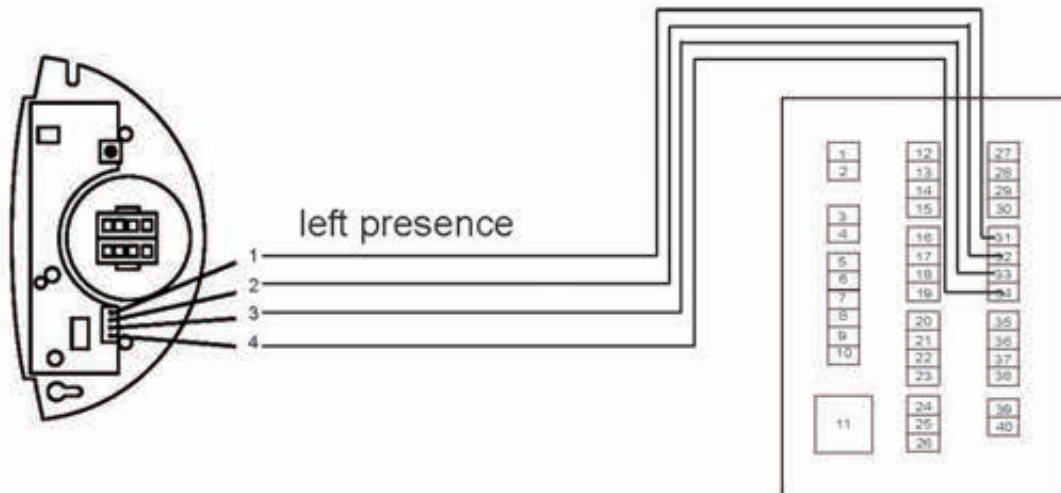
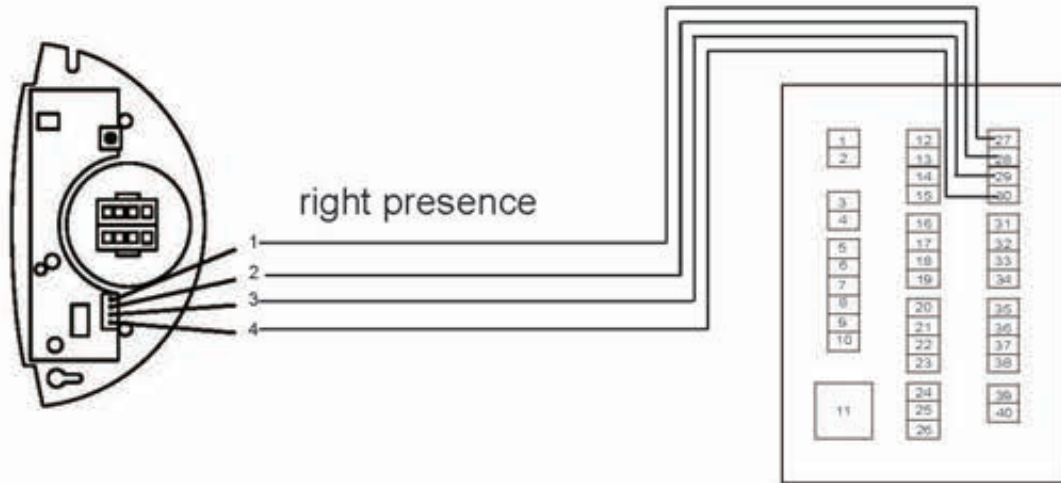

1.Brown 2.Green 3.White 4.Yellow

Connection of access keypad

Caution: All the connection should be conducted under the power off status.

When connect the access keypad should pay attention of positive and negative poles.

If the rate of work for access keypad is more than 2.4W, it needs the external power of 12V DC power.

● AK02

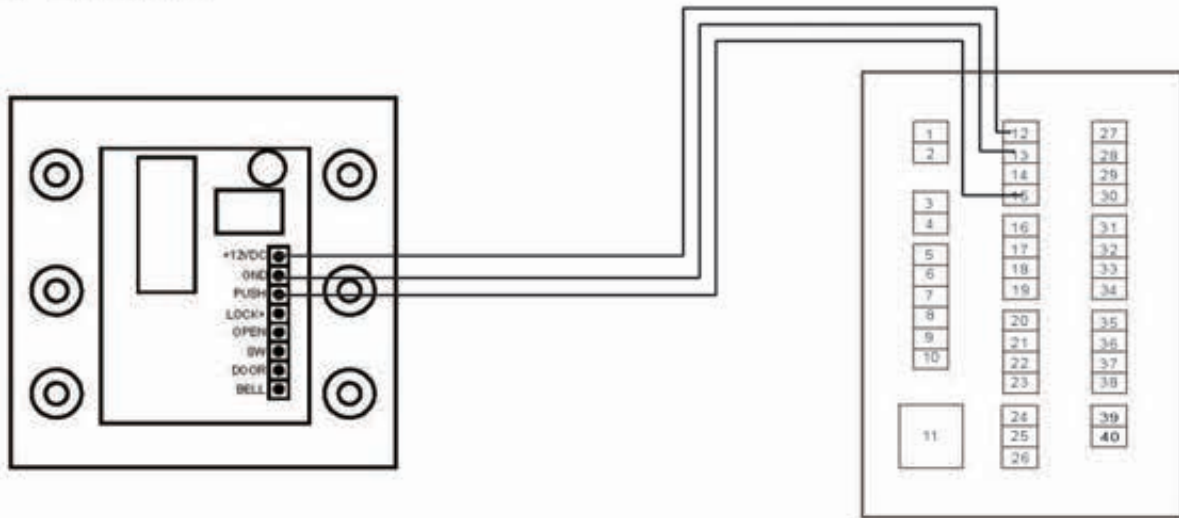

● AK04

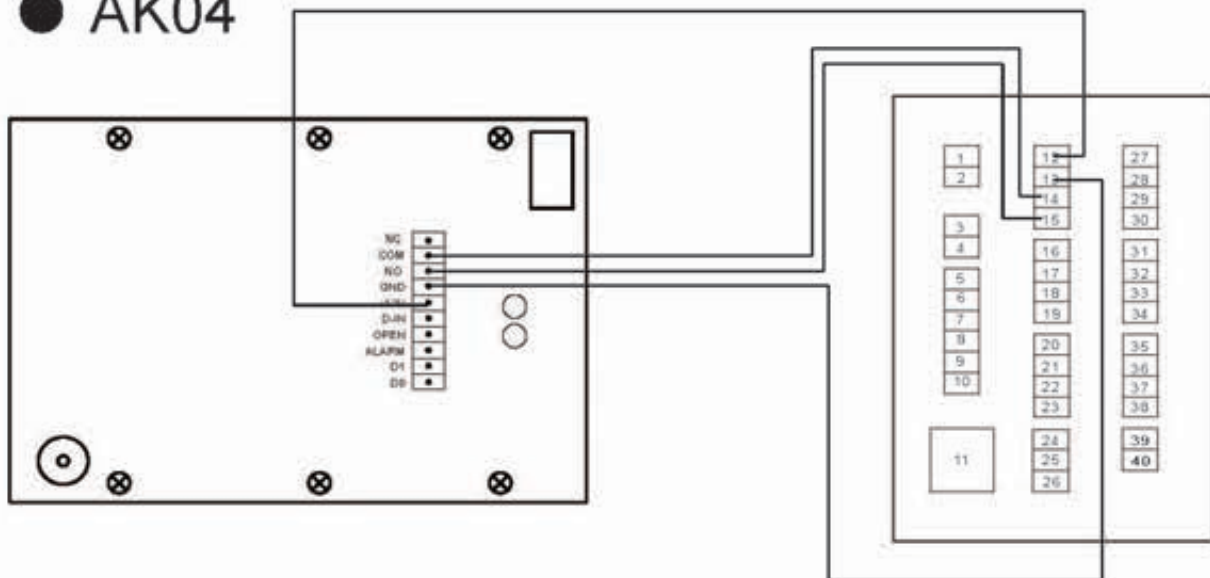

Connection of inter-lock



Connection of photocell

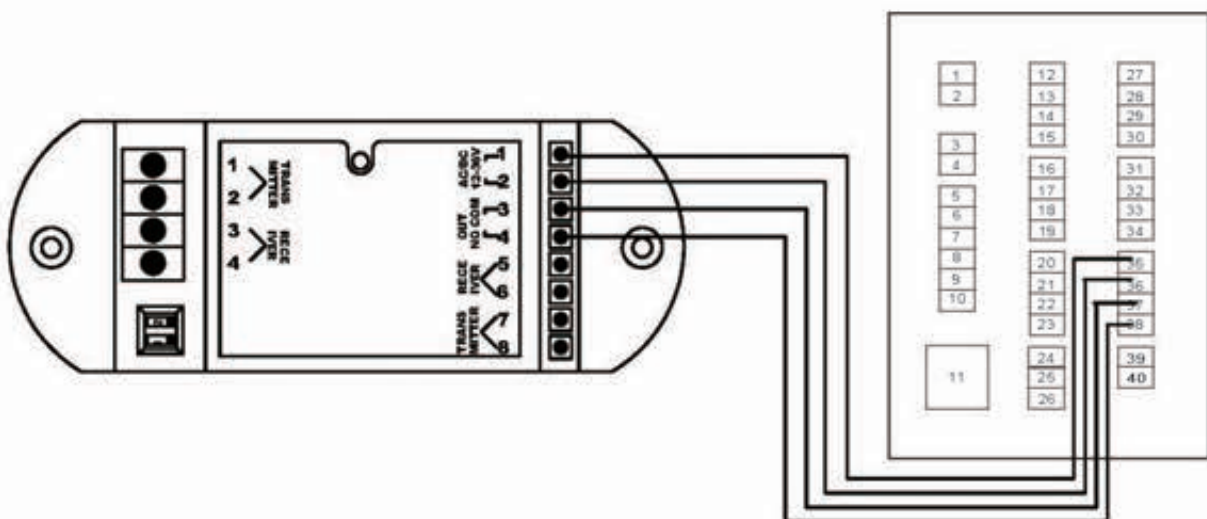

Connection of UPS

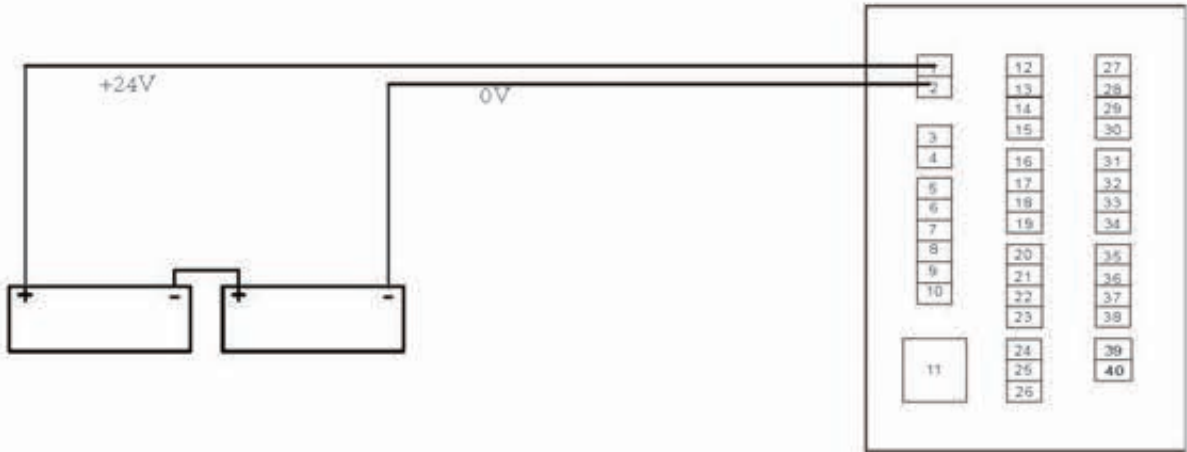

Connection of electronic lock

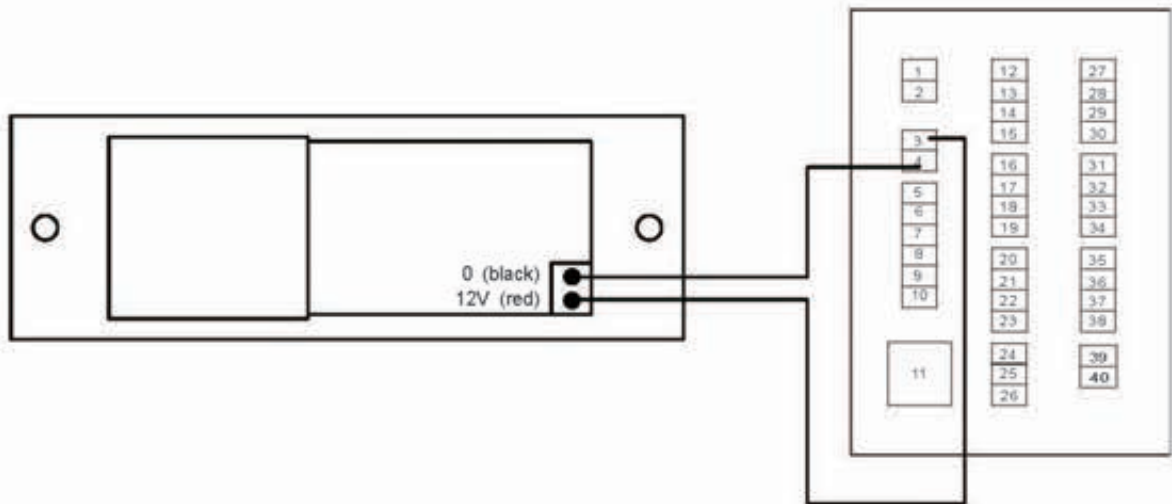

Connection of function keypad

● FC03

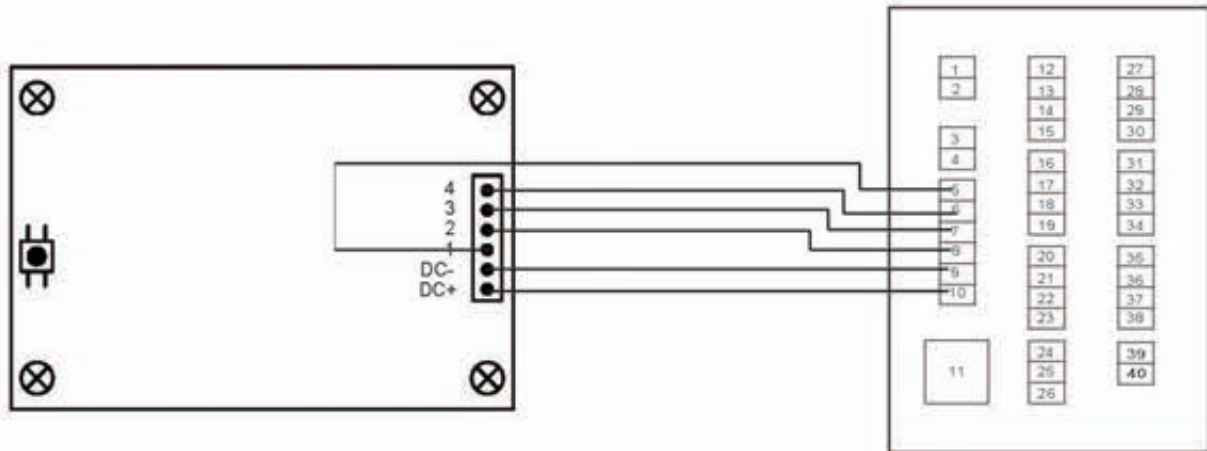

● FC06

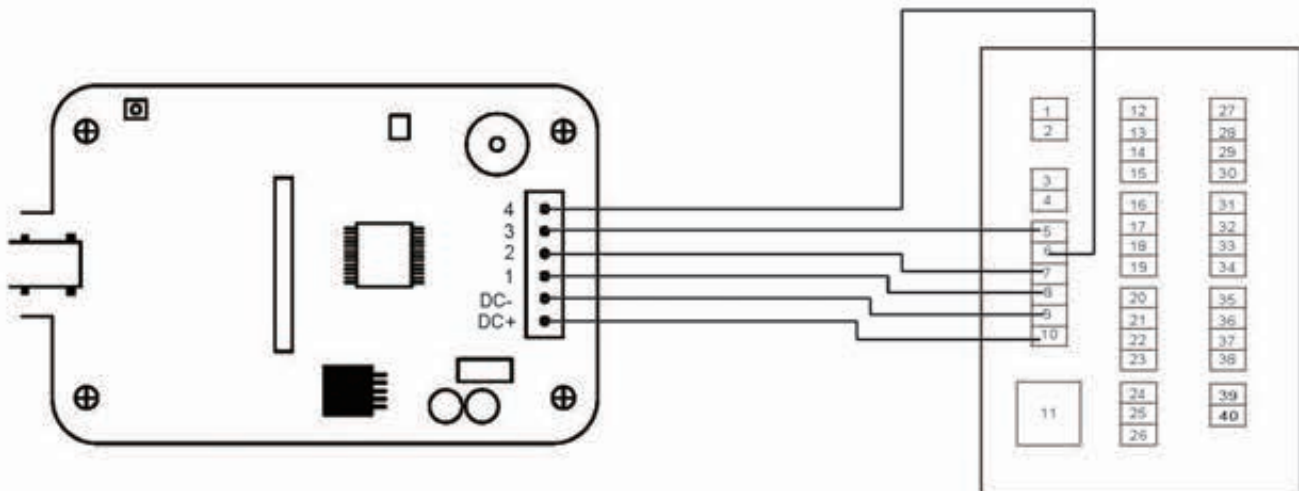

Data setting

Attention: Setting need to press the test button, Make sure mechanism stable operating, and not adjust data during operating.

Data adjustment is not allowed when door is operating

Code no.	Value range	Default value	Details
00	001	001	Software vision code
01	30-99	80	Opening speed
02	30-99	65	Closing speed
03	05-30	06	Braking speed when opening
04	05-30	06	Braking speed when closing
05	20-50	30	Braking distance when opening
06	10-50	30	Braking distance when closing
07	01-03	02	Auto reverse force when opening
08	01-03	02	Auto reverse force when closing
09	01-03	02	Holding force-closed
10	20-90	60	Partial opening(20%-90%)
11	00-60	02	Door hold time(0-60s)
12	00-01	00	Aux lock type(00: lock with power, 01: lock without power)
13	00-02	00	Battery mode(00: open/01: Closed/02: automatic)
14	00-01	00	Fire alarm mode(00: open:01: Closed)
15	00-01	00	Photocell signal (00: no/01: nc)
16	00-01	00	emergency stop NO signal active or NC signal active (00: no/01: nc)
17	00-01	01	External photocell status (00: disable/01: enable)
18	00-02	00	operating times selection: (00: unlimited 01:100000/02:10000)

reminder Er001 over-current protection
reminder Er002 Motor error

Description of operation

1. Power on, the mechanism start to self-learning. The door will open and close to find the opening and closing position.

2. The mechanism's working steps are as following:

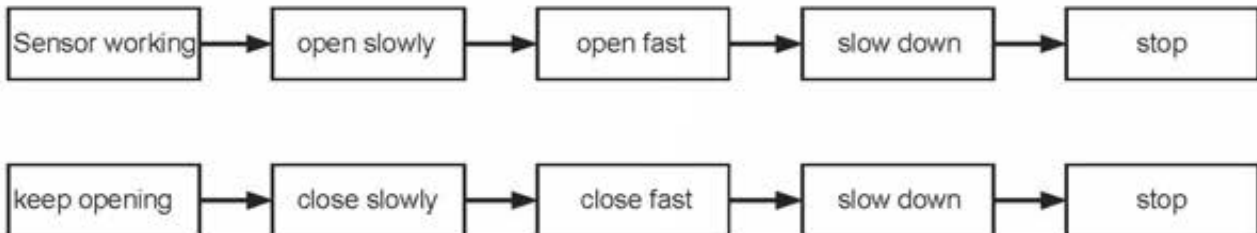

Trouble shooting

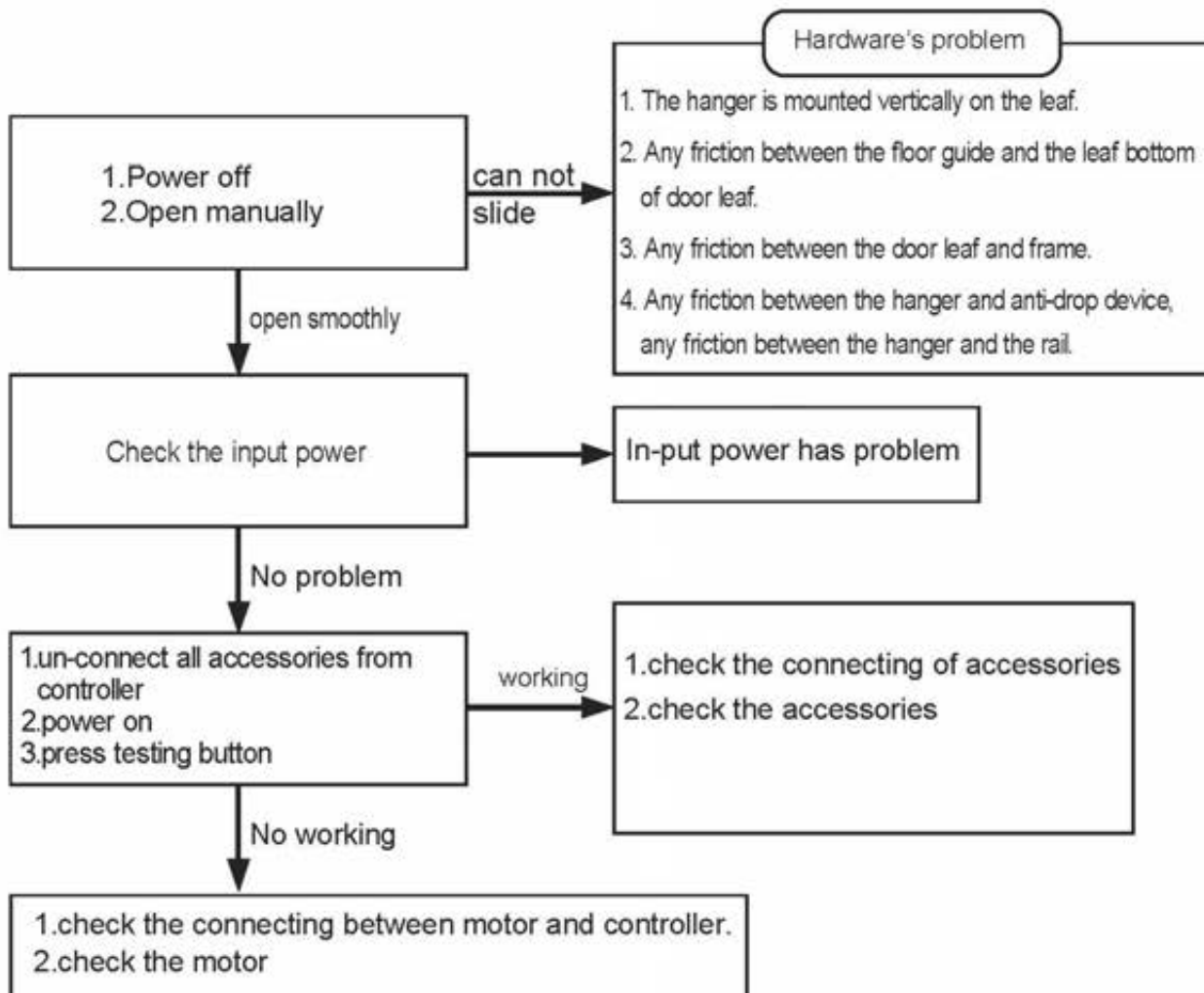

Trouble shooting

Symptoms	Causes	Troubles shooting	Remedy
Door leaves open or close un-smoothly	Opening or closing speed is set too slow	Check the data of opening and closing speed.	Adjust the opening or closing speed.
	Too much resistance when no power.	Any damager or loosen at hangers, floor guide or anti-drop device.	Fix the parts strongly. Fix the guide at the right position. Fix the anti-drop device.
		Any obstacle on the track.	Clean the track.
Door leaves hit each other when closing	Stopper is fixed not strongly.	Check the stopper.	Adjust the stopper's position and fix it.
	Closing speed is too fast and the buffer distance when closing is too small.	Check the closing speed and buffer distance when closing on controller.	Turn down the closing speed, and turn up the buffer distance when closing.
Door not working	No power input.	Check the outside input power.	Connection the power.
		Check the fuse of power switch.	Change a new fuse.
	Door is locked.	Check the lock is working or not.	Un-lock the door.
	Connection between motor and controller is not good.	Check the connection is good or not.	Connect them strongly.
	Inter-lock is working.	Check it works as inter-lock or not.	Waiting another door close.
Door does not close	Sensor is working.	Check the sensor is broken or not.	Use a new sensor.
		Check any stuff at the detecting area.	Clean the detecting area.
		Check the sensor is fixed stably.	Fix the sensor well.

Trouble shooting

Door does not close	Photocell is working.	Check the receiver and emitter are at same level or not.	Adjust position of receiver and emitter at same level.
		The surface of receiver and emitter is clean or not.	Clean the surface.
		Connection is good or not.	Connect the photocell the controller well.
	Function keypad or remote is working.	Check the button of always opening.	Re-set the function.
Door open by itself	Sensor work mistakes	Any stuff at the detecting area.	Move the stuff out the detecting area.
		Any fluorescent light near sensor.	Don't install the fluorescent light near sensor.
		Any strong microwave machine working near sensor.	Move the machine away sensor.