

# FLOOR SCRUBBER MODEL: F660

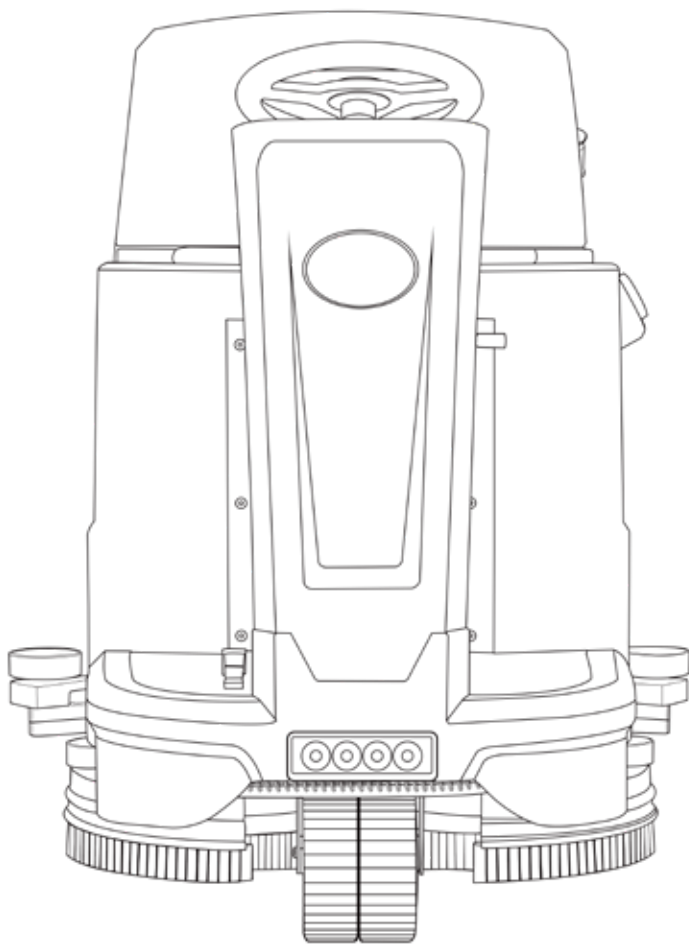

**INSTRUCTION MANUAL**

## ► INTRODUCTION

Each new machine is supplied with this Operation Manual, containing complete operating instructions and maintenance procedures.



**Before performing any operation or maintenance work, you must read this operation manual in full and familiarize yourself with the equipment.**

This equipment delivers exceptional floor maintenance and cleaning performance. To ensure optimal performance at the lowest operating costs, please strictly adhere to the following operating guidelines.

- The equipment must be operated in strict compliance with the operating procedures.
- This equipment must be maintained strictly in accordance with the maintenance instructions.
- This equipment must be maintained using original manufacturer parts or parts of equivalent quality.

### PROTECT THE ENVIRONMENT



Please dispose of packaging materials and used components (such as batteries and liquids) in an environmentally friendly manner and comply with local waste disposal regulations.



Please always consider possible recycling.

## ► INTENDED PURPOSE

The F660 is an industrial/commercial ride-on floor scrubber designed for cleaning flat and hard surfaces (e.g., concrete, tiles, stone, and plastic). Typical application scenarios include educational facilities, hospitals/medical institutions, office complexes, and retail centers.



**Do not use this machine on soil, grass, artificial turf, or carpeted surfaces.**

**The machine is intended for indoor use only and is not suitable for public roads.**

**Do not use the machine for purposes other than those described in this operating manual.**

---

**TABLE OF CONTENTS**

Safety precautions .....	01
Machine components .....	02
Operating controls .....	04
Main structure .....	05
Installation and operation .....	06
Operational precautions .....	08
Brushes and scouring pads .....	09
Drain the water tank .....	09
Battery installation .....	10
Battery charging .....	10
Circuit diagram .....	12
Troubleshooting guide .....	13
Machine maintenance .....	19
Machine parameters .....	20

## ► SAFETY PRECAUTIONS

This manual uses the following hazard symbols to alert operators to potential hazards.



**WARNING: Hazards or unsafe operations that may result in serious or fatal injury.**

**CAUTION: This notice covers the operational procedures that must be strictly followed to ensure safe machine operation.**

The following information alerts operators to potential hazards. Always remain vigilant to scenarios where these hazards may occur and thoroughly familiarize yourself with the locations of all safety devices on the machinery. Immediately cease operation if any machine damage or operational malfunction is detected.



### WARNING

- ① Ensure no electrical sparks or open flames are near the battery, as this poses a risk of explosion or fire.
- ② Flammable liquids may cause explosions or fires.  
Never inhale any flammable liquids, flammable gases, solvents, or acidic/alkaline liquids.
- ③ Flammable materials or reactive metals may cause explosions or fires.  
Never use this machine to process such substances.
- ④ Operation of the equipment by untrained or unauthorized personnel is strictly prohibited.  
The use of this equipment by children or individuals with disabilities is not allowed.
- ⑤ In case of fire, use a dry powder fire extinguisher. Water must not be used under any circumstances.
- ⑥ The machine's operational atmospheric humidity range is 30% to 95% (non-condensing).
- ⑦ Operate strictly within the manufacturer-specified climbing angle limit. When working on slopes with minimal gradients and elevations:
  - Exercise extreme caution during lateral operation.
  - Reverse operation is strictly prohibited.
  - Retract brush disc and water absorption rake assemblies when traversing inclines.
- ⑧ All machine maintenance and repair operations must be performed with the battery terminals disconnected.
- ⑨ Operation in special environments (e.g., pharmaceutical industry, hospitals, chemical plants) must strictly comply with all applicable safety standards and regulations.
- ⑩ Ensure no tools are left above battery terminals to prevent potential short circuits and explosion risks.
- ⑪ The machine's circuits and motors are water-resistant treated, however, the following cleaning specifications must be strictly observed:
  - High-pressure water jet cleaning is strictly prohibited.
  - Cleaning must be performed using low-pressure, non-corrosive water.
- ⑫ The filling funnel must remain installed during water tank refilling operations to prevent foreign object ingress that may damage the pump or clog the hydraulic system.

► MACHINE COMPONENTS

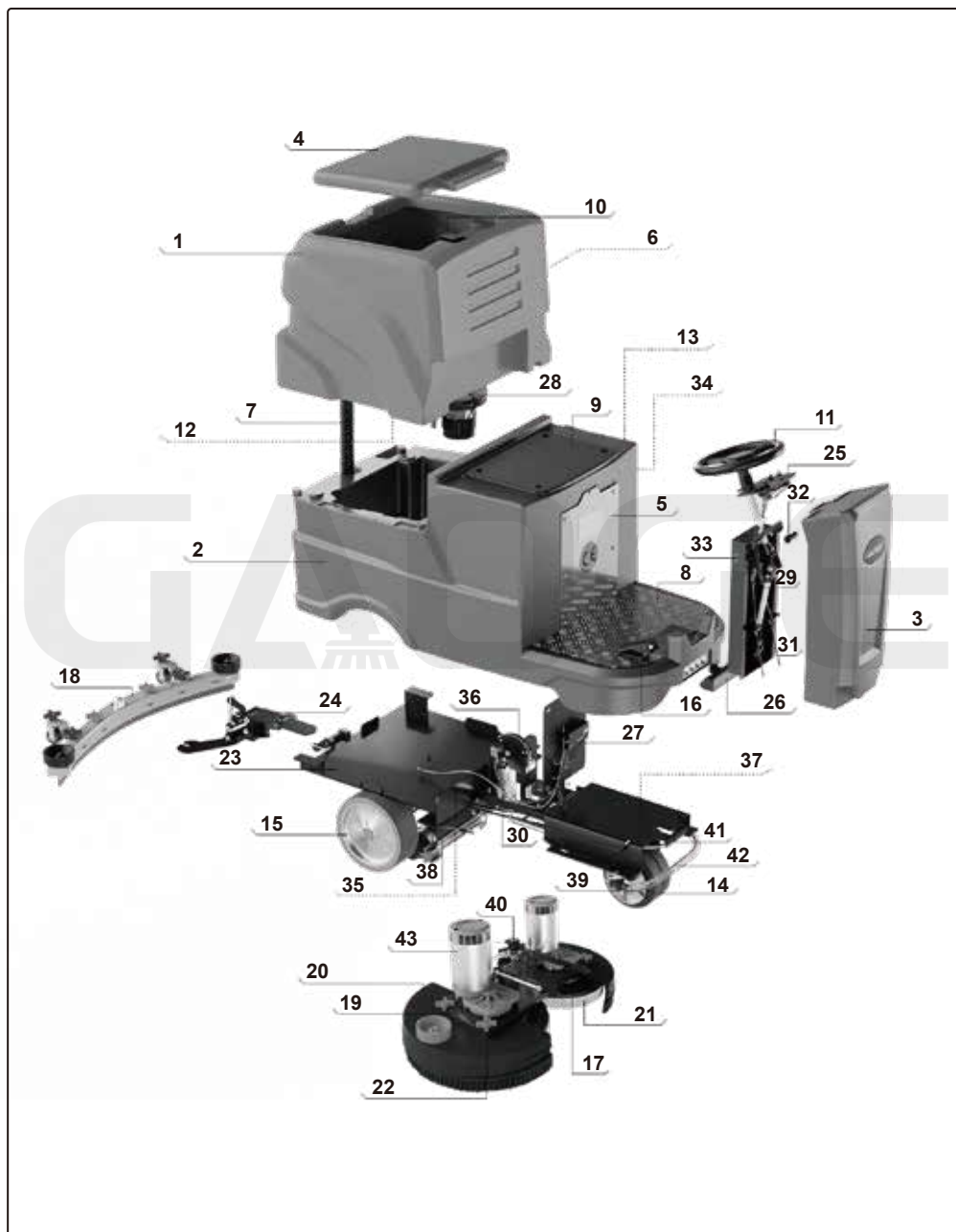

1. Dirty water tank
2. Clean water tank
3. Console housing
4. Sewage tank lid
5. Stainless steel electrical cover plate
6. Drain pipe
7. Suction hose
8. Aluminum step
9. Cushion
10. Float cage
11. Steering wheel
12. Submersible pump motor cover
13. Clean water tank Lid
14. Front wheel
15. Drive wheel
16. Accelerator pedal
17. Flange
18. Squeegee
19. Motor base
20. Water baffle
21. Brush
22. Nut
23. Chassis
24. Squeegee kit holder
25. Control panel
26. Lighting lamp
27. Controller
28. Vacuum motor
29. Steering linkage assembly
30. Push rod
31. Steel wire rope
32. Handle
33. Socket
34. Liquid level tube
35. Tension spring
36. Chain
37. Steering large gear
38. Rear axle assembly
39. Filter
40. Solenoid Valve
41. Valve
42. Steel wire hose
43. Brush motor

# GAODGE



## ► OPERATING CONTROLS

Centralized control panel, designed for intuitive and easy operation. When operating, please strictly follow these steps: Turn on the key switch and select the forward direction, then rotate the function knob to the "Brush Disc + Water Suction" position to start the system running.



**1** Trumpets

**2** Forward and backward

**3** LED light

**4** Key switch

**5** Squeegee and brush disk gear adjustment

## ► MAIN STRUCTURE

### DIRTY WATER TANK

The large-capacity dirty water tank design ensures operational efficiency, while the integrated water float ball device provides enhanced protection for the motor.

#### Before use, check the following:

1. Whether the dirty water tank lid is securely closed.
2. Whether the cleaning access cover at the bottom of the dirty water tank is properly closed and tightened.
3. Whether there is air leakage in the suction hose.



### CLEAN WATER TANK

The water tank features a sandwich-structured design with enlarged and thickened dimensions. Its hollow inner wall allows clean water to be filled, saving space and enhancing equipment efficiency.

### SQUEEGEE

The cast aluminum water absorption squeegee is robust and durable, while the natural rubber strip offers wear-resistant longevity. During machine operation, the scraping rubber of the suction squeegee maintains a slight rearward tilt at a specific angle relative to the ground surface. The enlarged and widened design doubles the cleaning efficiency.



### BRUSH

Wider dual brushes, paired with dual motors, significantly enhance efficiency.

Check the height of the brush plate of the floor scrubber every week. If the brush is worn out or the bristles are twisted, it is best to reassemble them to avoid the different inclinations of the bristles causing the brush motor to overload and vibrate too much.



► **INSTALLATION AND OPERATION**

**STEP 1**

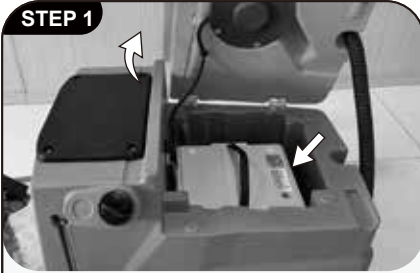

Open the dirty water tank cover and put in the battery.

**STEP 2**

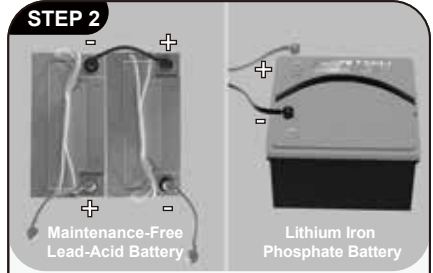

Connect the battery's positive and negative terminals with wires as shown in the picture, and then connect them to the device.

**STEP 3**

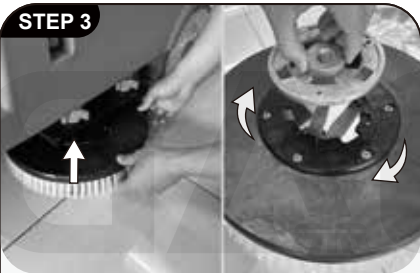

Align the brush plate with the upper flange, rotate it clockwise until the brush plate locks into place with the flange, and the installation is then complete.

**STEP 4**

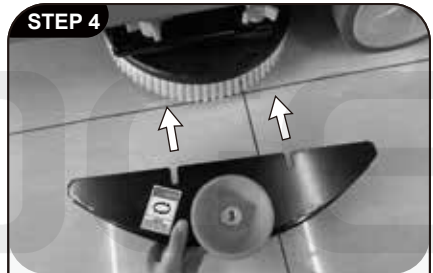

Align the grooves of the water shield with the two nuts on the brush plate, secure them in place, then tighten the nuts to complete the water shield installation.

**STEP 5**

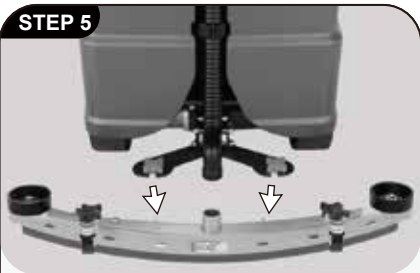

Install the squeegee assembly and tighten the knob securely. Connect the vacuum hose to the squeegee assembly, inspect the rubber blade, and make necessary adjustments.

**STEP 6**

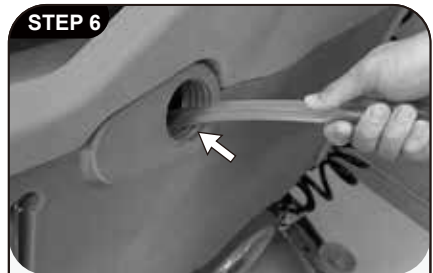

Open the water filler lid, align the hose with the water filler port, and fill the tank.

Note: If cleaning agent is added, an antifoaming agent must be simultaneously added to the dirty water tank to prevent motor damage.



Turn the ignition key switch to ON, select forward direction, then rotate the gear selector to engage brush and squeegee positions.

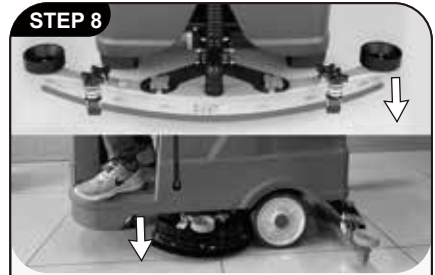

Lower both the brush plate handle and suction squeegee handle simultaneously.



Step on the accelerator pedal to begin efficient operation.

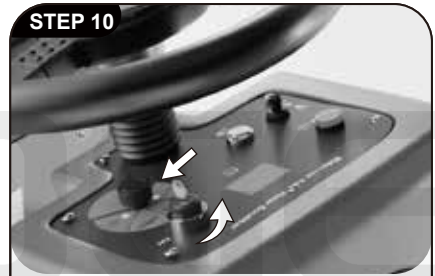

After cleaning completion, turn the ignition key to OFF, then rotate the gear selector to disengage squeegee and brush assemblies.



When the dirty water reaches full capacity, immediately disconnect the wastewater hose to drain the sewage.

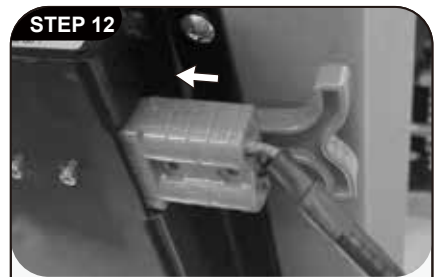

Recharge promptly after machine operation if insufficient charge remains!

## ▶ OPERATIONAL PRECAUTIONS

### PRE-OPERATION CHECK

- Remove dust from the floor.
- Verify the charge level indicators on the battery gauge. (refer to the battery gauge)
- Inspect wear condition of brushes/cleaning pads.
- Check the wear of the squeegee rubber blade and adjust the angle appropriately.
- Check the wear on the brush head skirt.
- Ensure the wastewater tank is empty and that a clean floating filter ball cage has been installed.

**NOTE: Before starting the machine, ensure all safety devices are properly positioned and functioning correctly.**

### DURING MACHINE OPERATION

- Ensure a 5 cm overlap between adjacent cleaning paths.
- Maintain continuous machine travel to prevent floor damage.
- If streaking occurs after using the squeegee, clean the rubber blade with a lint-free cloth to remove debris. Pre-sweep surfaces to eliminate potential contaminants that cause streaks.
- Do not operate the machine on slopes exceeding a 5% (3°) incline.
- When using detergent for cleaning, add defoamer solution to the wastewater tank to suppress foam formation.



**WARNING: Prevent foam ingress into the filter assembly to avoid suction motor damage. Foam accumulation may disable the safety switch mechanism.**

- When cleaning heavily soiled areas, first raise the squeegee to begin cleaning and allow the solution to soak for 3-5 minutes. Then lower the squeegee and repeat the cleaning process.
- Replace the scouring pad as needed based on the cleaning scenario.
- Monitor the battery power consumption (refer to the battery gauge).
- Check the remaining liquid level through the clean water tank level gauge. The traditional floor cleaning method consumes approximately 10 liters every 10 minutes.
- When the solution in the clean water tank is depleted, empty the waste water tank first before refilling with fresh solution.
- When the operator leaves the machine, park it on level ground and remove the key.
- After cleaning is completed, perform the daily maintenance procedures.

**NOTE: It is recommended to use a cleaning speed of 45-60 meters per minute.**

## ► BRUSHES AND SCOURING PADS

To ensure optimal performance, always use the correct brush type for cleaning tasks. Recommendations for using brushes and scouring pads are as follows:

### **White soft nylon brush**

Recommended for cleaning coated floors without damaging the surface.

### **White polishing pad**

Recommended for maintaining high-gloss or polished floors.

### **Red buffer pad**

Recommended for gently scrubbing away light dirt without damaging the floor.

### **Black gravity scrub pad**

Recommended for aggressively removing heavy coatings or substrates, or for ultra-intensive cleaning.

## INSTALL BRUSH AND SCRUB PAD

1. Park the machine on level ground and remove the key.
2. First place the scrub pad on the needle adapter, then install the drive plate. Secure the scrub pad by tightening the central lock.
3. Align the needle adapter/brush mounting stud with the motor drive plate latch, then press the brush motor switch.
4. To remove the needle adapter and brush, step on the brush head lifting pedal to raise the brush head off the ground, then press the brush motor switch.
5. Step on the brush head lifting pedal to raise the brush head off the ground.

**NOTE: For instructions on using brushes and scrub pads, refer to the usage recommendations for brushes and scrub pads provided above.**

## ► DRAIN THE WATER TANK

Drain and clean the dirty water tank after each use.  
Regularly clean the clean water tank to remove any corrosion.

Move the machine to the drainage area, turn off the power key, and drain the water according to the following instructions:

1. Rotate the drain pipe cap of the dirty water tank counterclockwise and remove it.
2. Open the dirty water tank cover and rinse the tank.
3. Remove and rinse the floating filter screen located inside the dirty water tank.

**NOTE: For safety reasons, before leaving the machine to drain, please ensure that the machine is parked on level ground, turned off, and the key is removed.**

## ► BATTERY INSTALLATION



**WARNING:** When installing the battery, ensure the machine key is in the OFF position and remove the key to prevent electric shock hazards!

**FOR SAFETY REASONS:** Wear protective gloves and eye protection when servicing the machine or handling the battery and battery terminals. Avoid contact with battery acid.

- Park the machine on level ground, shut down the machine, and remove the key.
- Lift the wastewater tank and place it into the battery compartment. Before connecting the battery, ensure that the electrodes and terminals are clean. Use an electrode cleaning wave and a soft brush as needed.

**NOTE:** Do not drop the battery into the battery compartment, as this may cause damage to both the battery and the machine.

- Connect the cables correctly according to the battery electrodes.

**NOTE:** Apply a thin layer of non-metallic grease or protective spray to the connected terminals to prevent battery corrosion.

- After the battery is securely installed, check the charge level on the battery indicator. Recharge the battery as needed.

## ► BATTERY CHARGING



### WARNING

To extend the battery life and ensure the machine's optimal performance, the battery must be charged only after the machine has been used for at least 30 minutes. Do not leave the battery in an uncharged state for extended periods. The following charging instructions apply to the charger provided with this machine.

**NOTE:** The battery's lifespan is limited by the number of charging cycles. To avoid permanent damage, ensure the battery is never fully discharged. Charge immediately when the battery indicator shows two bars remaining!

Battery voltage range: 21.2 V - 24.5 V, low voltage protection: 21.2 V, high voltage protection: 36 V.

**NOTE:** When the voltage is below 18.5 V, the low voltage protection will not report any undervoltage faults.

The brush motor, solenoid valve, and suction motor will stop operating if the battery voltage falls below the low voltage protection threshold or exceeds the high voltage protection threshold during operation. (When low or high voltage protection is triggered, the fault indicator light will turn off.)

## CHARGE THE BATTERY USING AN EXTERNAL CHARGER

**IMPORTANT NOTE:** Before charging, ensure the charger settings match the battery type.

1. Move the machine to a well-ventilated area.
2. Place the machine on a flat, dry surface and turn it off.
3. Before charging, check the electrolyte level in each cell of the battery.

**FOR SAFETY REASONS:** When servicing the machine, wear protective gloves and eye protection when handling the battery and battery terminals. Avoid contact with battery acid.

4. When charging, open the side of the wastewater tank to ensure ventilation. (As shown in the figure)



**WARNING:** The battery releases hydrogen gas, which poses a risk of explosion or fire. Keep away from electrical sparks or open flames near the battery. Keep the battery compartment open during charging.

5. Plug the charger into the machine's charging port.
6. Plug the battery charger into the power outlet.
7. The charger will automatically shut off after the battery is fully charged.

**NOTE:** The machine cannot be operated when connected to the charger.



**WARNING:** Do not disconnect the charger's DC cable from the machine's charging port while the charger is operating, as this may cause an arc discharge. If it is necessary to disconnect the charger during charging, first unplug the power cord from the outlet.

8. After charging is complete, check the electrolyte level again.



### WARNING

Please select the appropriate charger based on the battery type. Before charging, ensure that the charger settings match the battery type.

This device must be charged using the original manufacturer's charger or a charger with equivalent quality specifications.

►CIRCUIT DIAGRAM

ELECTRICAL SCHEMATIC—F660

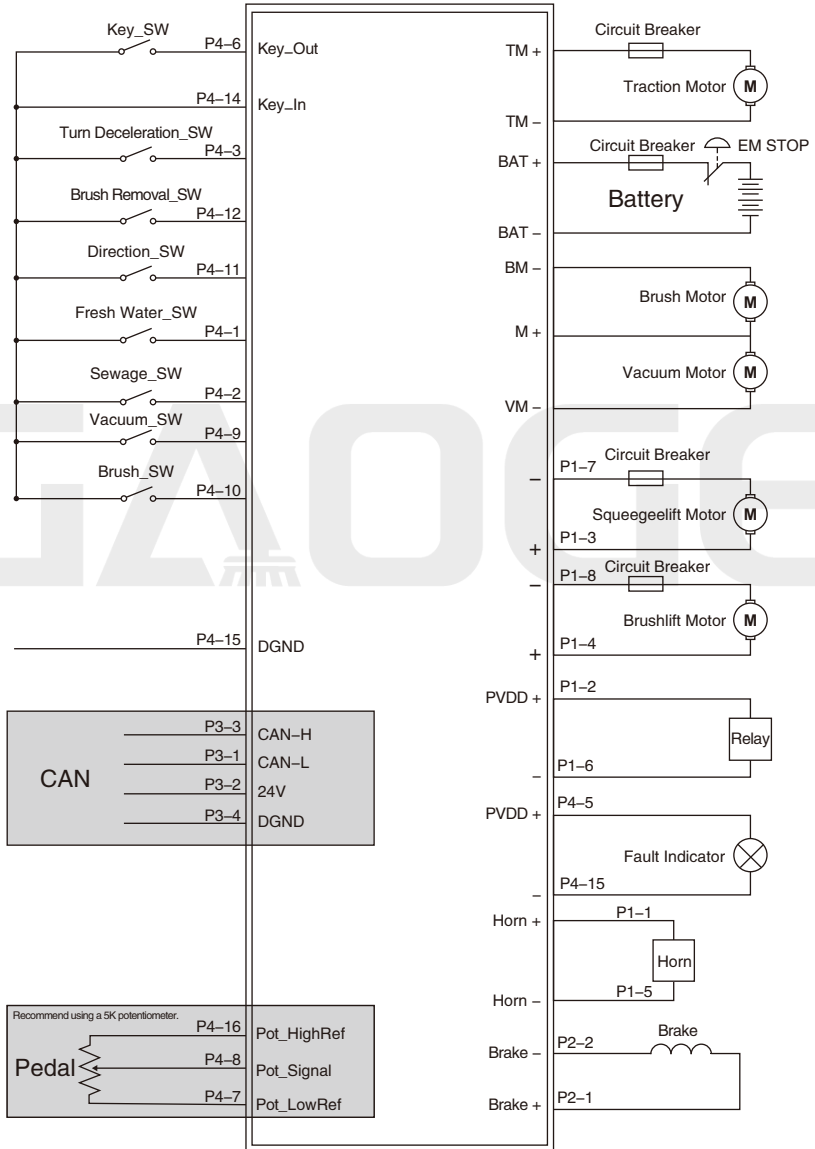

## ► TROUBLESHOOTING GUIDE

When a fault is detected in the drive system, operation should be halted. Please refer to the table below to determine the cause of the fault.

FAULT CODE	LED BLINKING	FAULT DESCRIPTION	DIAGNOSIS
E[01]	1 quick flash	Precharge fault 1.	1. Brake output short to ground. 2. Drive motor control mosfet or brake control mosfet failure in controller.  Troubleshooting: Disconnect the brake from the controller. If the fault clears: Check for brake circuit short to ground. If the fault persists: Confirm internal controller failure.
E[03]	3 quick flashes	PVDD1 over-voltage fault.	P2-1 voltage exceeds 34V.
E[04]	4 quick flashes	PVDD1 under-voltage fault.	P2-2 voltage drops below 12V.
E[07]	7 quick flashes	12V-CPU over-voltage fault.	Controller internal malfunction.
E[08]	8 quick flashes	12V-CPU under-voltage fault.	Controller internal malfunction.
E[12]	1 Slow, 2 Fast	Key Switch over-voltage fault.	P4-14/13 voltage above 34V.
E[13]	1 Slow, 3 Fast	Key Switch under-voltage fault.	P4-14/13 voltage below 12V.
E[14]	1 Slow, 4 Fast	Battery under-voltage fault.	Battery voltage below 12V.
E[15]	1 Slow, 5 Fast	Battery over-voltage fault.	Battery voltage above 34V.
E[16]	1 Slow, 6 Fast	Battery voltage limit low fault.	Battery voltage below 12V.
E[17]	1 Slow, 7 Fast	Battery voltage limit high fault.	Battery voltage above 36V.
E[25]	2 Slow, 5 Fast	UART over-voltage fault.	Controller internal malfunction.
E[26]	2 Slow, 6 Fast	UART under-voltage fault.	Controller internal malfunction.
E[29]	2 Slow, 9 Fast	Relay 1 connection fault.	Short circuit of traveling motor or ground fault of electromagnetic brake.
E[30]	Slow flash 3 times	Traveling motor Phase A NTC fault.	Controller internal malfunction.
E[31]	3 Slow, 1 Fast	Traveling motor Phase B NTC fault.	Controller internal malfunction.
E[32]	3 Slow, 2 Fast	Brush disk motor NTC fault.	Controller internal malfunction.
E[33]	3 Slow, 3 Fast	Suction fan motor NTC fault.	Controller internal malfunction.
E[34]	3 Slow, 4 Fast	Traveling motor Phase A control temperature overheat fault.	The temperature of the traveling motor drive circuit exceeds 75°C.
E[35]	3 Slow, 5 Fast	Traveling motor Phase A control temperature over-limit fault.	The temperature of the traveling motor drive circuit exceeds 85°C.



<b>FAULT CODE</b>	<b>LED BLINKING</b>	<b>FAULT DESCRIPTION</b>	<b>DIAGNOSIS</b>
E[36]	3 Slow, 6 Fast	Traveling motor Phase B control temperature overheat fault.	The temperature of the traveling motor drive circuit exceeds 75°C.
E[37]	3 Slow, 7 Fast	Traveling motor Phase B control temperature over-limit fault.	The temperature of the traveling motor drive circuit exceeds 85°C.
E[38]	3 Slow, 8 Fast	Brush disk motor control temperature overheat fault.	The temperature of the brush disk motor drive circuit exceeds 75°C.
E[39]	3 Slow, 9 Fast	Brush disk motor control temperature over-limit fault.	The temperature of the brush disk motor drive circuit exceeds 85°C.
E[3A]	3 Slow, 10 Fast	Suction fan motor control temperature overheat fault.	The temperature of the suction fan motor drive circuit exceeds 75°C.
E[40]	Slow flash 4 times	Suction fan motor control temperature over-limit fault.	The temperature of the suction fan motor drive circuit exceeds 85°C.
E[41]	4 Slow, 1 Fast	Traveling motor Phase A MOS high voltage fault	The Phase A voltage of the traveling motor is excessive. Disconnect the traveling motor wiring from the controller, restart the controller, and observe the fault. If the fault persists, it indicates an internal fault within the controller. If the fault disappears, check whether the traveling motor wiring has a short circuit with the battery positive (+) terminal.
E[42]	4 Slow, 2 Fast	Traveling motor Phase A MOS low voltage fault.	The Phase A voltage of the traveling motor is too low. Disconnect the traveling motor wiring from the controller, restart the controller, and observe the fault. If the fault persists, it indicates an internal fault within the controller. If the fault disappears, check whether the traveling motor wiring has a short circuit with the battery positive (+) terminal.
E[43]	4 Slow, 3 Fast	Traveling motor Phase B MOS high voltage fault	The Phase B voltage of the traveling motor is excessive. Disconnect the traveling motor wiring from the controller, restart the controller, and observe the fault. If the fault persists, it indicates an internal fault within the controller. If the fault disappears, check whether the traveling motor wiring has a short circuit with the battery positive (+) terminal.
E[44]	4 Slow, 4 Fast	Walking motor Phase B MOSFET low voltage fault.	If the Phase B voltage of the drive motor is too low, disconnect the drive motor wiring from the controller and restart the controller. If the fault persists, it indicates an internal fault in the controller. If the fault disappears, check whether the drive motor wiring is shorted to the battery positive (+) terminal.
E[45]	4 Slow, 5 Fast	Brush disk motor MOSFET high voltage fault.	/

FAULT CODE	LED BLINKING	FAULT DESCRIPTION	DIAGNOSIS
E[46]	4 Slow, 6 Fast	Brush disk motor MOS low voltage fault.	Brush disk BM- undervoltage. Troubleshooting: Disconnect the brush disk motor from the controller and restart the system. If the fault disappears, check for a ground short circuit in the brush disk motor. If the fault persists, the issue is likely an internal fault within the controller.
E[47]	4 Slow, 7 Fast	Suction motor MOS high voltage fault.	/
E[48]	4 Slow, 8 Fast	Suction motor MOS low voltage fault.	Suction motor VM low voltage fault. Troubleshooting: Disconnect the suction motor from the controller and restart the controller. If the fault disappears, check whether the suction motor is shorted to ground. If the fault persists, the issue is likely an internal fault within the controller.
E[63]	6 Slow, 3 Fast	Walking motor open circuit fault.	Troubleshooting: 1. Check for an open circuit in the drive motor: Disconnect the drive motor from the controller and measure the continuity between the two motor wires. 2. Verify proper wiring: Ensure the connections between the drive motor and the controller are correctly configured.
E[64]	3 Slow, 4 Fast	Travel motor MOS-A short circuit fault.	For a drive motor short circuit, restart and check if the fault disappears. If the fault occurs every time it runs, inspect whether the motor is damaged or if there is a short circuit to external components.
E[65]	6 Slow, 6 Fast	Travel motor MOS-B short circuit fault.	Travel motor short circuit. Restart and check if the fault clears. If it consistently recurs during operation, inspect the motor for damage or any external short circuit.
E[66]	6 Slow, 6 Fast	Travel motor overload fault.	/
E[67]	6 Slow, 7 Fast	Brush motor open circuit fault.	Troubleshooting: 1. Check for open circuit in the brush motor: Disconnect the brush motor from the controller and measure continuity between the two motor wires. 2. Verify wiring connections between brush motor and controller: Inspect whether the motor-circuit connections to the controller terminals are properly configured.
E[68]	6 Slow, 8 Fast	Brush motor short circuit fault.	Brush motor short circuit. Restart and check if the fault clears. If it consistently recurs during operation, inspect the motor for damage or any external short circuit.

FAULT CODE	LED BLINKING	FAULT DESCRIPTION	DIAGNOSIS
E[69]	6 Slow, 9 Fast	Brush motor overload fault.	Brush motor operating current and duration have exceeded the preset protection thresholds. Check for stall conditions or other unexpected situations.
E[6A]	6 Slow, 10 Fast	Suction motor open circuit fault.	<p>Troubleshooting:</p> <ol style="list-style-type: none"> <li>1. Check for open circuit in the suction motor: Disconnect the suction motor from the controller and measure continuity between the two motor wires.</li> <li>2. Verify wiring connections between suction motor and controller: Inspect whether the motor-circuit connections to the controller terminals are properly configured.</li> </ol>
E[70]	Slow flash 7 times	Suction motor short circuit fault.	Suction motor short circuit. Restart and check if the fault clears. If it consistently recurs during operation, inspect the motor for damage or any external short circuit in the wiring harness.
E[71]	7 Slow, 1 Fast	Suction motor overload fault.	Suction motor operating current and duration have exceeded the preset protection thresholds. Check for impeller jam or other system anomalies.
E[86]	8 Slow, 6 Fast	Output point 1 (P1-5) open circuit fault.	<p>Output point 1 horn connection fault.</p> <p>Troubleshooting:</p> <ol style="list-style-type: none"> <li>1. Disconnect the horn and test for continuity: Remove the horn assembly and measure continuity across its terminals to verify open circuit status.</li> <li>2. Inspect wiring integrity and connections: Verify correct wiring configuration between controller and horn, including checking the entire wire run for breaks.</li> </ol>
E[87]	8 Slow, 7 Fast	Output point 1 (P1-5) short circuit fault.	<p>Output point 1 horn short circuit detected.</p> <p>Troubleshooting:</p> <ol style="list-style-type: none"> <li>1. Test for internal short in horn: Measure resistance between the two horn wires. An abnormally low reading (<math>&lt;1\Omega</math>) indicates a short circuit.</li> <li>2. Check whether the horn is short-circuited to B- or B+.</li> </ol>
E[88]	8 Slow, 8 Fast	Output point 2 (P1-6) open circuit fault.	<p>Output point 2 incorrectly connected—solenoid valve.</p> <p>Troubleshooting:</p> <ol style="list-style-type: none"> <li>1. Remove the solenoid valve and measure whether it has an open circuit.</li> <li>2. Check if the wiring is correct and if there are any broken wires in the connections.</li> </ol>

FAULT CODE	LED BLINKING	FAULT DESCRIPTION	DIAGNOSIS
E[89]	8 Slow, 9 Fast	Output point 2 (P1-6) short circuit fault.	<p>Output point 2: Solenoid valve connection short circuit.</p> <p>Troubleshooting:</p> <ol style="list-style-type: none"> <li>1.Check for a short circuit between the two wires of the solenoid valve (low resistance).</li> <li>2.Check whether the solenoid valve is shorted to ground (B-) or power supply (B+).</li> </ol>
E[8A]	8 Slow, 10 Fast	Output point 3 (P2-2 Electromagnetic Brake) open circuit fault.	<p>Output point 3: Electromagnetic brake not properly connected.</p> <p>Troubleshooting:</p> <ol style="list-style-type: none"> <li>1.Remove the electromagnetic brake and test for an open circuit in the brake coil.</li> <li>2.Verify correct wiring connections and check for wire breaks along the wiring harness.</li> </ol>
E[90]	Slow flash 9 times	Output point 3 (P2-2 Electromagnetic Brake) short circuit fault.	<p>Output point 3: Electromagnetic brake connection short circuit.</p> <p>Troubleshooting:</p> <ol style="list-style-type: none"> <li>1.Check for a short circuit between the two wires of the electromagnetic brake (low resistance).</li> <li>2.Check whether the electromagnetic brake is shorted to ground (B-) or power supply (B+).</li> </ol>
E[91]	9 Slow, 1 Fast	Output point 4 (P4-5) open circuit fault.	<p>Output point 4: Malfunction indicator lamp not properly connected.</p> <p>Troubleshooting:</p> <ol style="list-style-type: none"> <li>1.Remove the malfunction indicator lamp and test for an open circuit.</li> <li>2.Verify correct wiring connections and check for wire breaks along the wiring harness.</li> </ol>
E[92]	9 Slow, 2 Fast	Output point 4 (P4-5) short circuit fault.	<p>Output point 4: Malfunction indicator lamp connection short circuit.</p> <p>Troubleshooting:</p> <ol style="list-style-type: none"> <li>1.Check for a short circuit between the two wires of the malfunction indicator lamp (low resistance).</li> <li>2.Check whether the malfunction indicator lamp is shorted to ground (B-) or power supply (B+).</li> </ol>
E[99]	9 Slow, 9 Fast	Throttle connection fault.	<p>Check if the throttle input voltage is within the controller-configured operational range.</p>
E[A1]	10 Slow, 1 Fast	High pedal inhibit fault.	<p>High Pedal Inhibit - The vehicle enters a drivable state immediately upon power-on. Verify the directional gear position and throttle input.</p> <p>Check whether the throttle input voltage is within the controller-configured operational voltage range.</p>

<b>FAULT CODE</b>	<b>LED BLINKING</b>	<b>FAULT DESCRIPTION</b>	<b>DIAGNOSIS</b>
E[A2]	10 Slow, 2 Fast	Rotary brush low voltage fault.	The battery voltage is below the configured brush protection voltage threshold; refer to the battery type to determine the required protection voltage.
E[A3]	10 Slow, 3 Fast	Suction blower low voltage fault.	The battery voltage is below the configured suction blower protection voltage threshold; refer to the battery type to determine the required protection voltage.
E[A4]	10 Slow, 4 Fast	System time memory corruption.	Controller internal fault.
E[A5]	10 Slow, 5 Fast	Parameter storage failure.	Controller internal fault.
E[A6]	10 Slow, 6 Fast	System information storage error.	Controller internal fault.
E[A7]	10 Slow, 7 Fast	PFC file storage fault.	Controller internal fault.
E[A8]	10 Slow, 8 Fast	Program file corruption.	Controller internal fault.
E[A9]	10 Slow, 9 Fast	Emergency stop activation fault.	Controller internal fault.
E[AA]	10 Slow, 10 Fast	Reverse lockout failure.	Controller internal fault.
E[97]	9 Slow, 8 Fast	CAN bus offline fault.	/

## ► MACHINE MAINTENANCE

Please strictly adhere to the daily, weekly, and monthly maintenance procedures to ensure the machine remains in optimal working condition!



**Warning: Electric shock hazard. Disconnect the battery terminals before servicing the machine.**

### DAILY MAINTENANCE (AFTER EACH USE)

1. Drain and clean the dirty water tank.
2. Remove and rinse the floating filter screen inside the dirty water tank.
3. Drain the clean water tank, and rinse the tank with hot water not exceeding 60°C if necessary.
4. Remove the cleaning pad/brush for cleaning. If worn, flip or replace the cleaning pad.
5. Wipe the squeegee blade. Store the squeegee assembly in the raised position to prevent blade damage.
6. Check the wear on the scraper edge of the squeegee blade. If worn, swap the blade ends.
7. Wipe the machine with a multi-purpose cleaner and a damp cloth.

**NOTE: For safety purposes, do not use high-pressure spray or flush the machine with a water hose during cleaning to avoid causing malfunctions in electronic components.**

8. Check the wear condition of the brush head skirt. Replace immediately if worn or damaged.
9. Charge the battery only after the machine has been used for more than 30 minutes each time, to prolong the battery's service life and ensure optimal machine performance.

### MONTHLY MAINTENANCE (EVERY 80 HOURS OF USE)

1. Remove and clean the clean water tank filter from beneath the machine.  
Ensure the clean water tank is emptied before removing the filter.
2. Clean the battery terminals to prevent corrosion (refer to "Battery Maintenance").
3. Check the battery terminals for looseness.
4. Inspect and clean the seal on the dirty water tank lid. Replace if damaged.
5. Spray silicone-based dry lubricant on all pivots and rollers, then apply a layer of water-resistant lubricating oil to maintain smooth axle operation.
6. Check all nuts and bolts on the machine for tightness.
7. Inspect the machine for leaks.

### QUARTERLY MAINTENANCE

1. Every 250 hours: Inspect the carbon brush wear on the drive motor (drive-type models), vacuum motor, and brush motor.
2. Replace carbon brushes when their length is worn down to within 10 mm. If the machine requires servicing, contact an authorized service center.

**► MACHINE PARAMETERS**

<b>MODEL</b>	<b>F660</b>	<b>COMMENTS</b>
Working width	660mm	
Squeegee width	920mm	
Working capacity	3955m <sup>2</sup> /h	
Brush diameter	330mm*2	
Brush motor	24V/380W*2	
Motor speed	180rpm	
Vacuum motor	24V/500W	
Motor pressure	145mbar	
Clean/Dirty water tank	85L/85L	
Batteries	12V/100Ah*2	
Noise level	≤68dB(A)	
Net/Gross weight	215/325kg	
Brush pressure	38kg/cm <sup>2</sup>	
Max gradient	16%	
Drive motor	24V/500W	
Machine size(L*W*H)	1370*690*1085mm	

**GAOGE<sup>®</sup>**

**FLOOR SCRUBBER  
INSTRUCTION MANUAL**

**Zhangjiagang Gaoge Cleaning Equipment Co. , Ltd.**

 [www.gaogecleaning.com](http://www.gaogecleaning.com)

 Houcheng Tanshang Industrial Park , zhangjiagang , Jiangsu , China