



Professional Air Tank Manufacturer

Customized Solutions



Providing High-quality Products & Service to
Global Automation Equipment Enterprises





Company Information

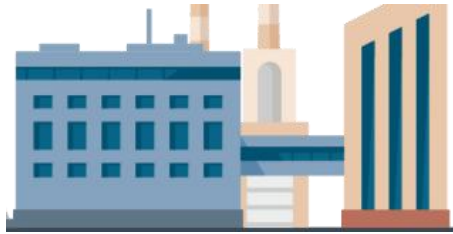

3 Factories

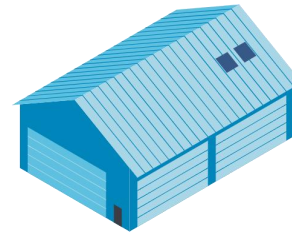

4 Warehouses

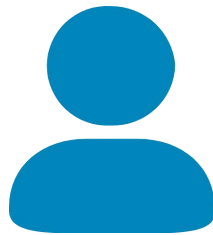

200 staff

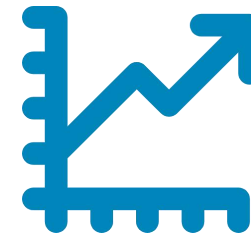

\$15M Annual Sales



Development:



2013

Established in Jiangsu



2017

Set up Jiangxi Guangfeng Plant



2020

Set up Jiangsu Sufit Plant



2025

Build automation production line



2025

Enlarge to 25000m²



2024

Got ASME certification



3 Factories



**YCZX- headquarter
in Kunshan**



**Sufit-plant
in Yangzhou**



**Guangfeng-plant
in Jiangxi**

3 Warehouses in China

01



Kunshan

02



Yangzhou

03



Guangdong



Main Products:

Air Tank



Electric Motor



Defoam Tank



Booster Tank



Pump Station



Air Tanks



Horizontal carbon steel air tank



Vertical carbon steel air tank



Horizontal aluminum alloy air tank



Horizontal stainless steel mirror air tank



Vertical stainless steel mirror air tank

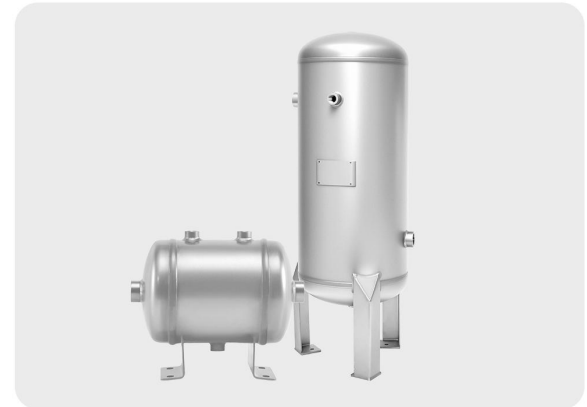

Stainless steel frosted air tank



Booster Valve & booster tank



Air pressure boosting valve



VBA booster valve

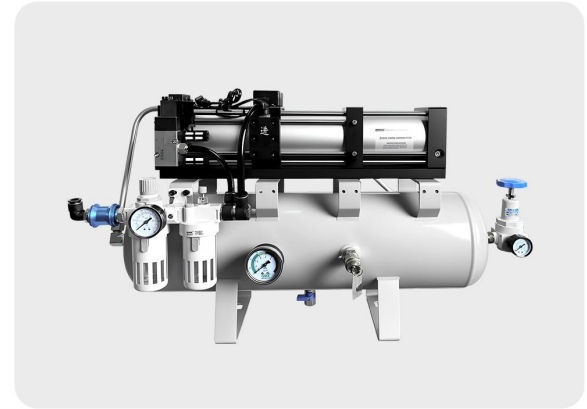

Air pressure booting valve set



Stainless steel booster tank



Carbon steel booster tank



Boost valve boost tank two-piece kit

Pump Stations



air compressor



Oil free vacuum pump station



Rotary vane vacuum pump station



Water ring vacuum system



Automatic drainage negative pressure station





Dofoam Bucket



SS defoam bucket (transparent cover)



SS defoam bucket



SS pressure tank



Foam bucket combination



Foam bucket combination



Foam bucket combination



Customized Air Tanks



Workshops & Machines



Crafts



Polishing



Plate Rolling



Welding

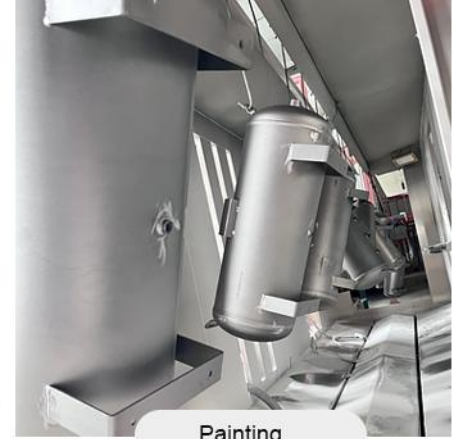

Painting

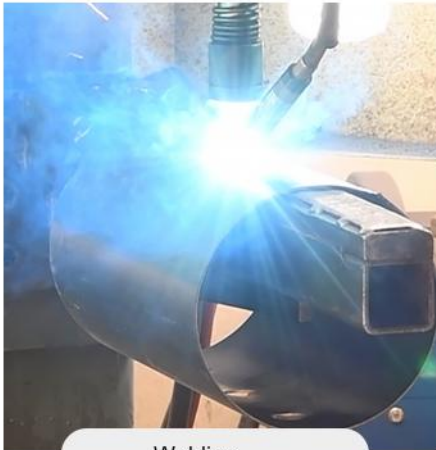

Welding



Polishing



Water Pressure Test



Punching



Quality Control-Certificates



The American Society of Mechanical Engineers

CERTIFICATE OF AUTHORIZATION

The named company is authorized by The American Society of Mechanical Engineers (ASME) for the scope of activity shown below in accordance with the applicable rules of the ASME Boiler and Pressure Vessel Code. The use of the ASME Single Certification Mark and the authority granted by this Certificate of Authorization are subject to the provisions of the agreement set forth in the application. Any construction stamped with the ASME Single Certification Mark shall have been built strictly in accordance with the provisions of the ASME Boiler and Pressure Vessel Code.

COMPANY:

Jiangsu Sufit Machinery Equipment Co., Ltd.
Building 3, Baqiao Industrial Parks, Xiejia Town, Gaoyou City
Yangzhou City, Jiangsu Province ,
People's Republic of China

SCOPE:

Manufacture of pressure vessels at the above location only

AUTHORIZED: **March 11, 2024**
EXPIRES: **March 11, 2027**
CERTIFICATE NUMBER: **61438**

Gary L. Scribner
Board Chair,
Conformity Assessment



Matthew Vangues
Senior Director,
Engineering Operations

ASME-U



The American Society of Mechanical Engineers

CERTIFICATE OF AUTHORIZATION

The named company is authorized by The American Society of Mechanical Engineers (ASME) for the scope of activity shown below in accordance with the applicable rules of the ASME Boiler and Pressure Vessel Code. The use of the ASME Single Certification Mark and the authority granted by this Certificate of Authorization are subject to the provisions of the agreement set forth in the application. Any construction stamped with the ASME Single Certification Mark shall have been built strictly in accordance with the provisions of the ASME Boiler and Pressure Vessel Code.

COMPANY:

Jiangsu Sufit Machinery Equipment Co., Ltd.
Building 3, Baqiao Industrial Parks, Xiejia Town, Gaoyou City
Yangzhou City, Jiangsu Province ,
People's Republic of China

SCOPE:

Manufacture of miniature pressure vessels at the above location only

AUTHORIZED: **March 11, 2025**
EXPIRES: **March 11, 2026**
CERTIFICATE NUMBER: **61437**

Gary L. Scribner
Board Chair,
Conformity Assessment



Matthew Vangues
Senior Director,
Engineering Operations

ASME-UM

Certificate

Module A2
in accordance with Directive 2014/68/EU

Certificate no.: 01 202 CHN-U-240012

Name and address of the manufacturer: Jiangsu Sufit Machinery Equipment Co., Ltd.
Building 3, Baqiao Industrial Parks, Xiejia Town, Gaoyou City,
Yangzhou City, Jiangsu Province, 225600, P. R. China

According to the test results, the manufacturer is entitled to mark the pressure equipment produced within the range of this module with the mark

CE 0035

Tested acc. to Directive 2014/68/EU: **Module A2 - Internal production control plus supervised pressure equipment checks at random intervals**

Test report no.: CHN-U-240012M1

Description of pressure equipment: Air Tank in Category II according to Drawing No.: SFT-100(350)0.8-CE, Rev.0.

Manufacturing plant/Supplier: Jiangsu Sufit Machinery Equipment Co., Ltd.
Building 3, Baqiao Industrial Parks, Xiejia Town, Gaoyou City,
Yangzhou City, Jiangsu Province, 225600, P. R. China

During the periodical monitoring, compliance with the directive has been demonstrated.
The next monitoring will be performed until: January / 2025

Shanghai, July 03, 2024



LU Ping
Expert

TÜV Rheinland Industrie Service GmbH
Notified Body for Pressure Equipment, ID-No. 0035
Am Grauen Stein, D-51105 Köln, GERMANY

www.tuv.com
T1.30 MS-0001602 Rev.6



TÜVRheinland®
Precisely Right.

CE



Quality Control-Certificates

上海市特种设备监督检验技术研究院
中国上海金沙江路915号
电话总机: 86-21-32584900
传真: 86-21-32584961
邮政编码: 200062



SHANGHAI INSTITUTE OF SPECIAL EQUIPMENT
INSPECTION & TECHNICAL RESEARCH
915 Jin Sha Jiang Road Shanghai China
Tel: 86-21-32584900
Fax: 86-21-32584961
Zip Code: 200062

MR2024-351

CERTIFICATE OF INSPECTION

I, Sun Jiexi being an Approved Inspector of Shanghai Institute of Special Equipment Inspection and Technical Research, an authorized inspecting body named in the First Schedule to the Occupational Safety And Health (Plant Requiring Certificate Of Fitness) Regulations 2024, P.U.(A)99/2024, Malaysia, hereby certify that AIR TANK, Serial No. A240637 was constructed by Jiangsu Suifu Machinery Equipment Co., Ltd. in accordance with their drawing number SFTT-10(203)1.3-00, Rev.0

It was surveyed during construction by me and the scantlings are in accordance with ASME BPV Code Section VIII Div.1 2023 Edition for a design pressure of 1.3MPa. The workmanship is good.

The reports of samples of all materials used in its construction were reviewed by me and found to comply with the provisions of the above-mentioned Code.

On completion the pressure vessel was tested hydrostatically to 1.2MPa for a period of 30 minutes in my presence on Nov. 28, 2024. It showed no signs of weakness and was found tight and sound in every respect at that pressure. It was stamped by me as follows:

Dated this 3rd day of December 2024.

(Signed) Sun Jiexi
孙界喜 (Sun Jiexi)
Approved Inspector

王海荣
王海荣 (Wang Hairong)
Chief Engineer to Inspecting Authority



www.ssei.cn

SSEI

中华人民共和国 特种设备生产许可证

Production License of Special Equipment
People's Republic of China

编号: TS2236605-2029

单位名称: 江西光丰机械有限公司
住所: 江西省萍乡市萍乡经济技术开发区彭高镇 319 国道边动漫工业园内 2 号靠近 X121、朝阳中路辅路和 X121 辅路 (5 号车间)
制造地址: 江西省萍乡市萍乡经济技术开发区彭高镇 319 国道边动漫工业园内 2 号靠近 X121、朝阳中路辅路和 X121 辅路 (5 号车间)

经审查,获准从事以下特种设备生产活动:

许可项目	许可子项目	许可参数	备注
压力容器制造(含安装、修理、改造)	固定式压力容器 中、低压容器 (D)		(设计外委) 限: 第一类固定式压力容器, 设计压力范围无限制, 持证

发证机关: 江西省市场监督管理局
有效期至: 2029 年 03 月 08 日 发证日期: 2024 年 12 月 26 日

Production License



质量管理体系认证证书

兹证明
江苏苏飞特机械设备有限公司
统一社会信用代码: 91321084MA21N55X23

注册地址: 高邮市八桥工业集中区 (扬州市飞扬电器有限公司内) 邮编: 225600
审核地址: 江苏省扬州市高邮市八桥集中区 邮编: 225600

其质量管理体系经中盛认证有限公司评定符合
GB/T19001-2016/ISO9001:2015 标准
认证范围:
资质范围内压力容器的生产

证书编号: ZSRZ231454QZRO8
证书签发日期: 2023 年 10 月 24 日
初次获证日期: 2023 年 10 月 24 日
证书有效期至: 2026 年 10 月 23 日



证书签发: 李娟
证书专用章

本证书的有效性由中国国家认证认可监督管理委员会官方网站(www.cca.gov.cn)上查询
获证组织必须每年定期接受监督审核,并符合获证条件方可保持有效
地址: 江苏省徐州市铜山区淮海文化科技产业园 A1 楼 329
电话: 400-100-2902

ISO9001

Quality Control Process



Incoming Inspection



Welding Inspection



Welding non-destructive testing



Pressure Testing



Dimension Inspection



Painting Inspection

Quality Control-Inspection



ASME water pressure inspection



Corrosion Inspection



Leakage test



Worldwide Customers



Exported to 155 countries, including Europe, North America, South America, Asia, etc



Customer Reference

HITOP

 **E·MC[®]**

FOXCONN[®]
富士康

FESTO

 **SMC[®]**

 **昊华科技**
HAOHUA TECHNOLOGY

CATL
宁德时代

BYD
比亚迪汽车

LUXSHARE ICT
立讯精密

 **清华大学**
Tsinghua University

 **北京大学**
PEKING UNIVERSITY

 **武汉大学**
WUHAN UNIVERSITY

 **湖南大学**
HUNAN UNIVERSITY

 **上海交通大学**
SHANGHAI JIAO TONG UNIVERSITY

 **中国海洋大学**
OCEAN UNIVERSITY OF CHINA

 **河北工业大学**
HEBEI UNIVERSITY OF TECHNOLOGY



Shipments





New Products-inside rustproof

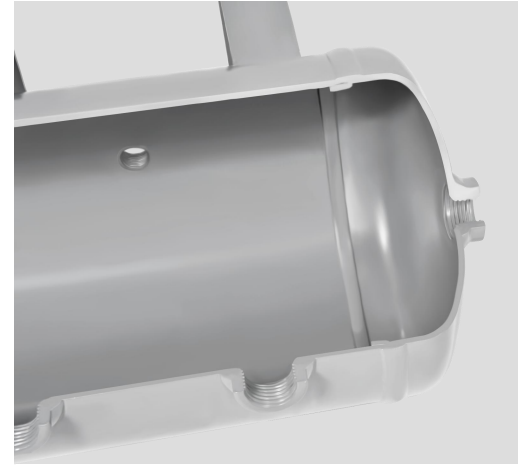

Carbon Steel Air Tanks with inside rustproof



New Products-inside rustproof

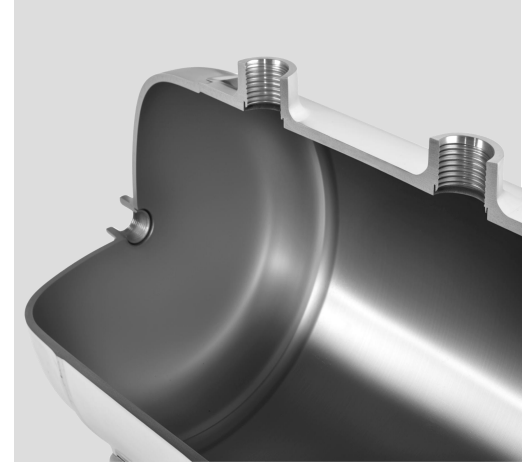
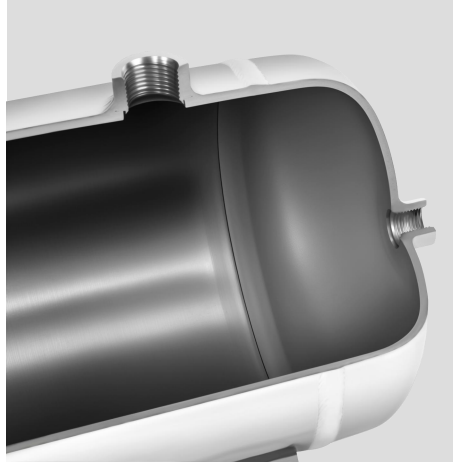

Stainless Steel Air Tanks with inside rustproof



New Product-Automatic Prouduction line

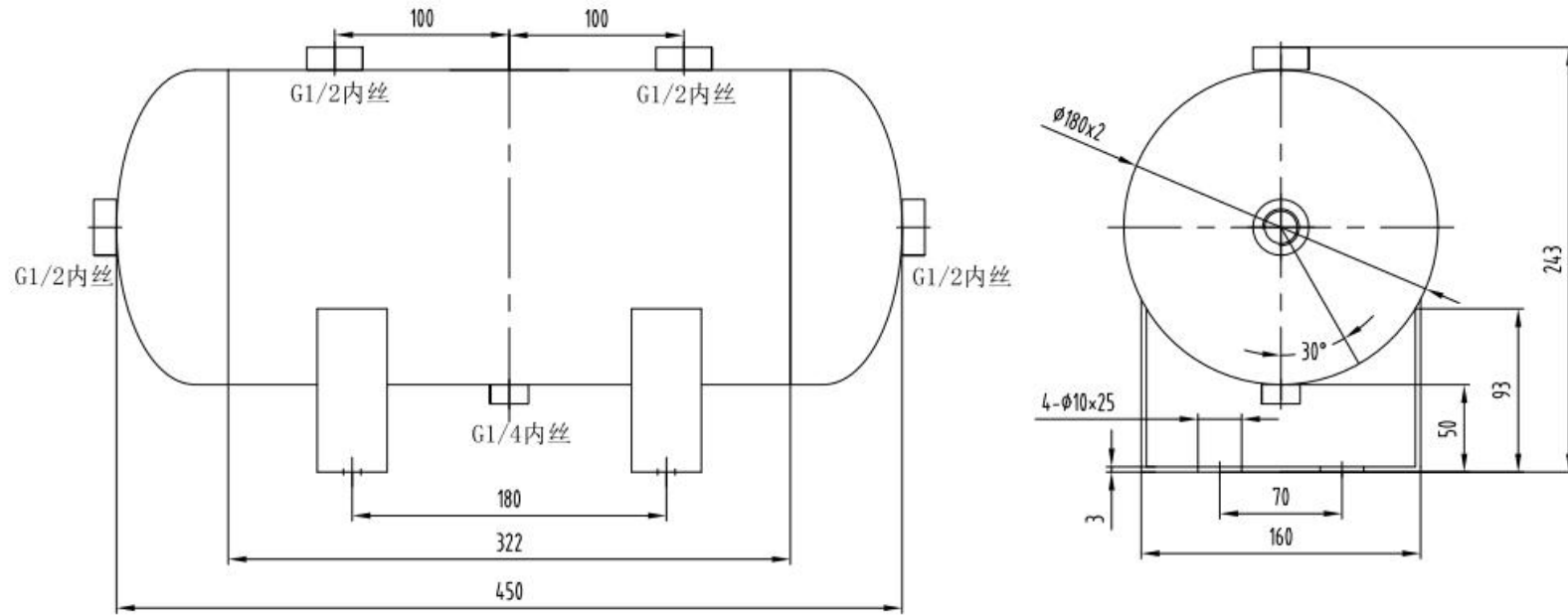

10L-180x450x2



New Product-Automatic Prouduction line

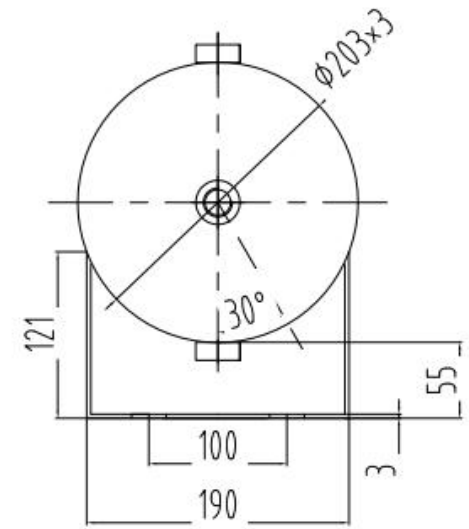
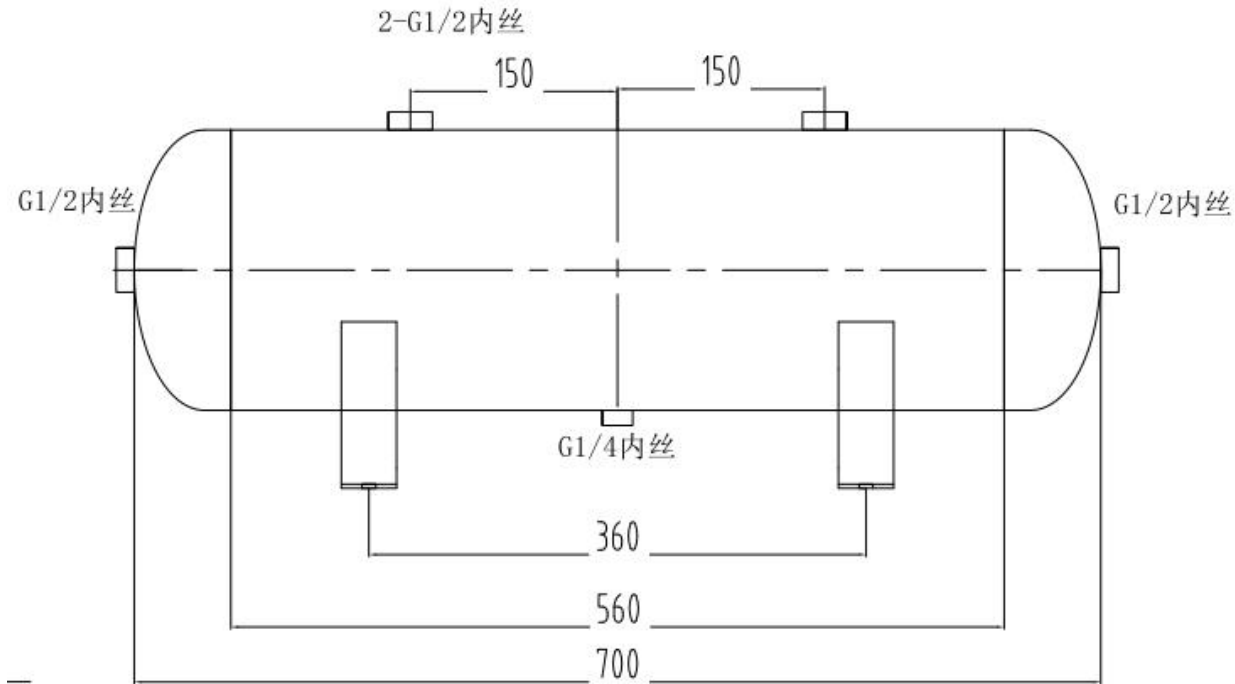

20L-203x700x3



New Product-Automatic Prouduction line

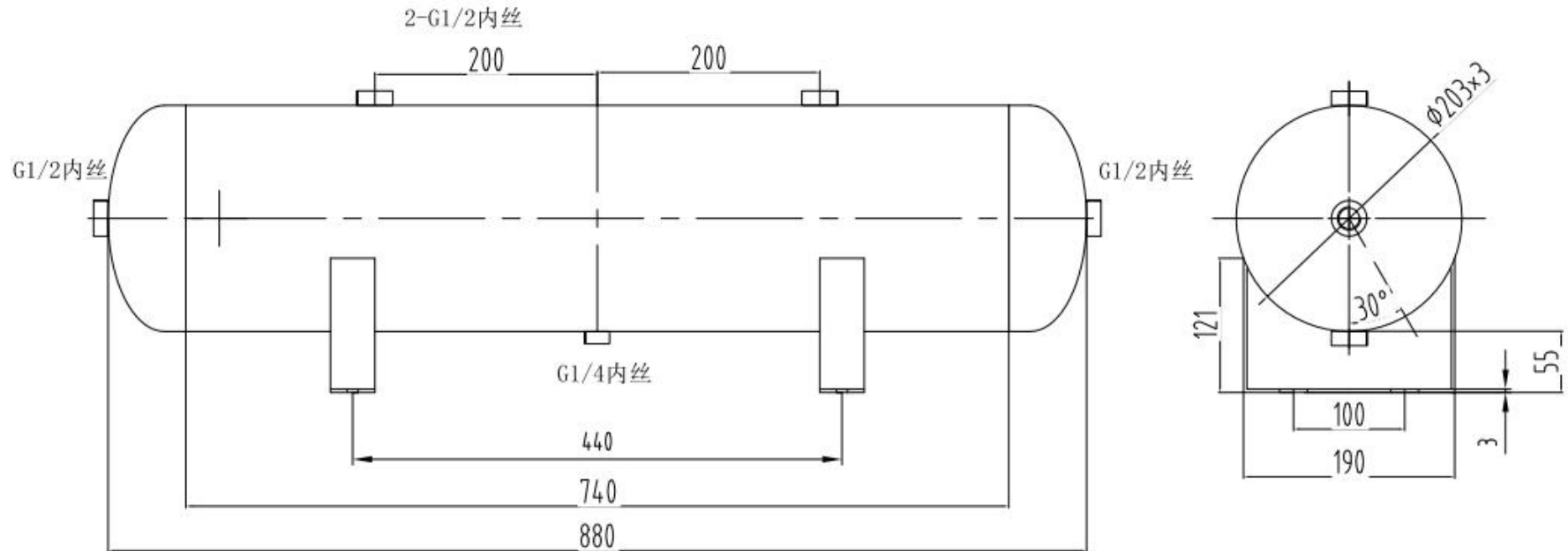

25L-203x880x3



Contact us

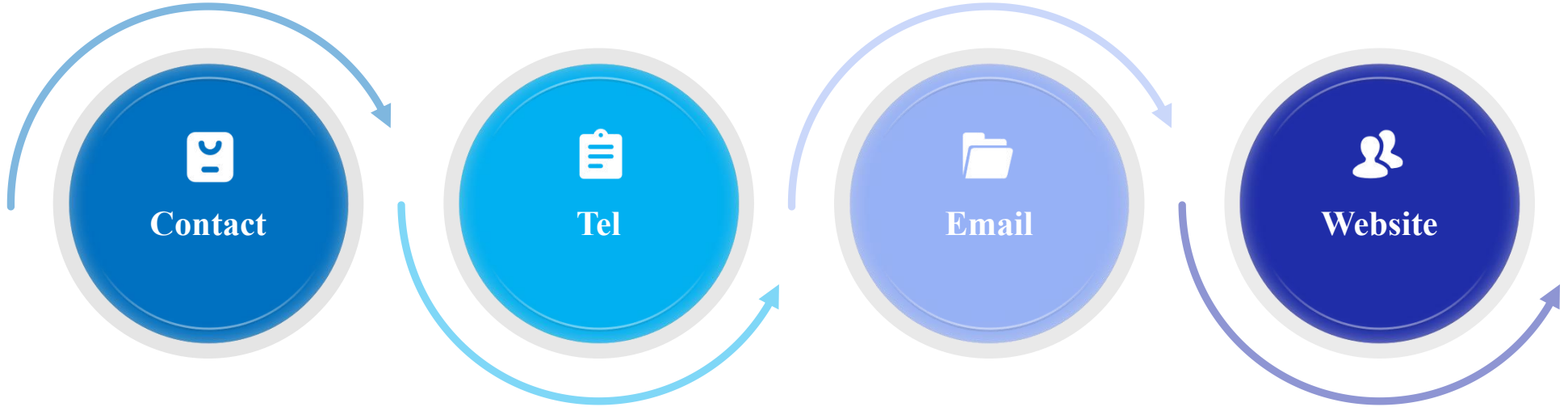

Sally PAN

+86-18963671291

sally.pan@youchengzhixin.com

www.youchengzhixin.com



Contact us

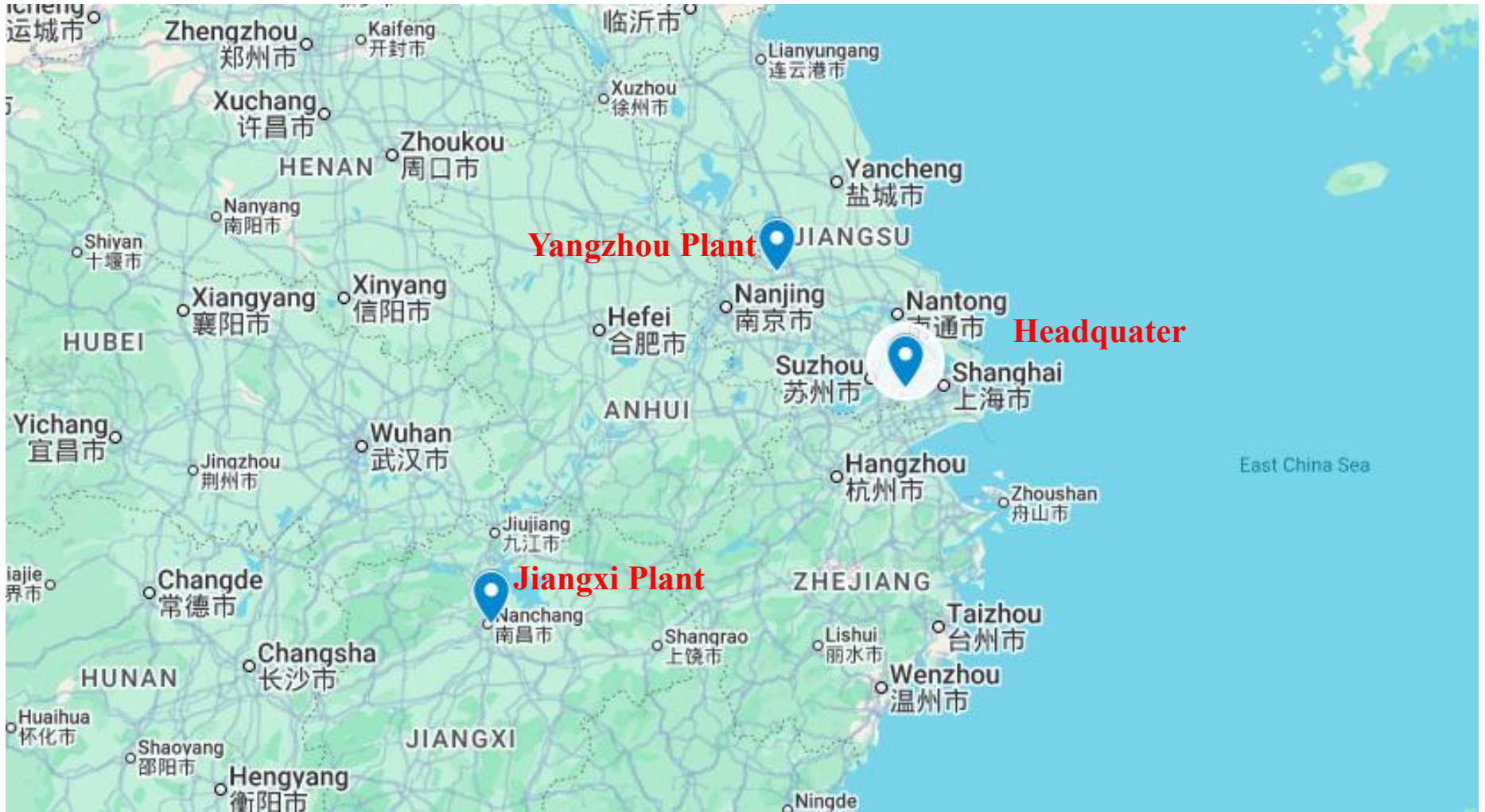

A series of approximately ten thin, light blue wavy lines that flow from the left side of the slide towards the right, creating a sense of movement and depth.

Thanks