



YORKLUN

# **CURTAIN TRACKS & CURTAIN RODS RIPPLE FOLD CURTAIN TRACKS**

HOSPITALITY | COMMERCIAL | PRIVATE CLUB | APARTMENT

## INTRODUCTION

If windows are the eyes of a room, curtains and tracks are the eyelashes. To ensure the curtain system can be well finished, curtain track is essential and required to be flexible.

Our curtain track comply various functions, the unique overlap carriers are able to fully block the lights, the magnetic carriers are able to close the joint. The tracks can be mounted on walls or mounted on ceilings, it can also be embedded to be invisible.

All curtain rails are equipped with needed accessories and guidance for installation, we are confident to guarantee 10 years warranty under normal conditions.



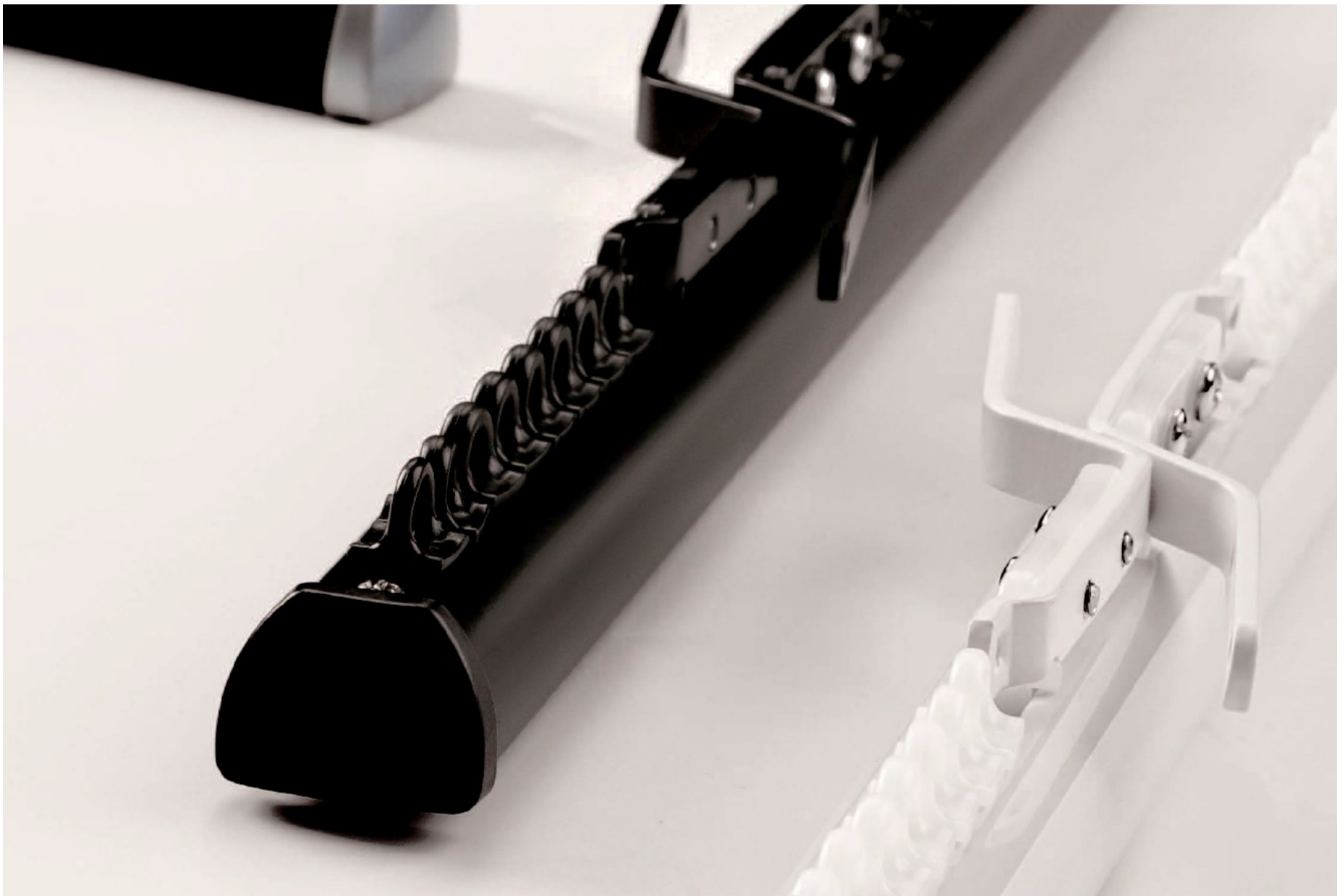

**6300 MAGNATIC / 6400 OVERLAP  
CURTAIN TRACK SYSTEM**



## 6300 MAGNETIC -

magnetic and silent hand drawn system for **light to medium** weight draperies



### COLORWAYS

6300-01      BLACK MATT



6300-02      IVORY WHITE



# 6300 MAGNETIC -

magnetic and silent hand drawn system for **light to medium** weight draperies

## PRODUCT INFORMATION

- **Track finish:** 6063-T5 aluminium with electrophoretic coating
- **Dimension:** 26 mm x 18.3 mm
- **Thickness:** 1.9 mm aluminum extrusion
- **Weight capacity:** 6-8 kg per meter
- **Durability:** able to run over 5000 times with 4kg on each carrier
- **Bendable:** it can be bent and reversed bent using a 10 cm (4") radius or continuous curve, available on request
- **Suitable for special window decoration** as circular, arch and triangle window models
- **Special colors:** available on request

## PRODUCT DIMENSION

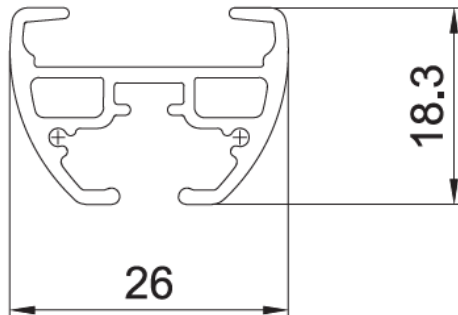

## Mount on ceiling - single track instruction

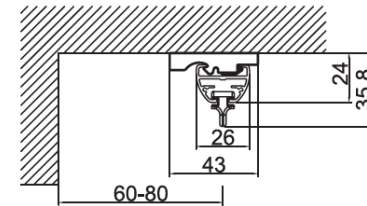

## Mount on ceiling - double track instruction

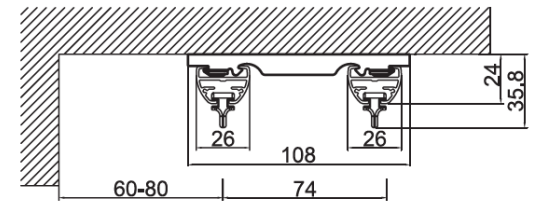

## Mount on wall - single track instruction

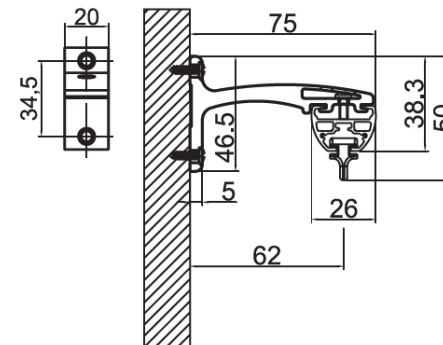

## Mount on wall - double track instruction

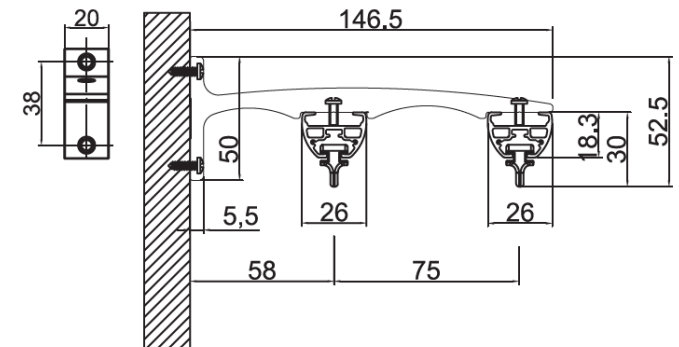

# 6400 OVERLAP -

highly efficient hand drawn system for **light to medium** weight draperies



## COLORWAYS

6400-01 BLACK MATT



6400-02 NAVY BLUE



6400-03 CHAMPAGNE GOLD



6400-04 IVORY WHITE

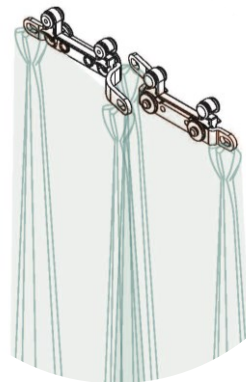

\* two more pleats are suggested for overlap carrier  
\* 2.3 - 2.5 times fabric quantity is suggested



# 6400 OVERLAP -

highly efficient hand drawn system for **light to medium** weight draperies

## PRODUCT INFORMATION

- **Track finish:** 6063-T5 aluminium with electrophoretic coating
- **Dimension:** 26 mm x 18.3 mm
- **Thickness:** 1.9 mm aluminum extrusion
- **Weight capacity:** 6-8 kg per meter
- **Durability:** able to run over 5000 times with 4kg on each carrier
- **Bendable:** it can be bent and reversed bent using a 10 cm (4") radius or continuous curve, available on request
- **Suitable for special window decoration** as circular, arch and triangle window models
- **Special colors:** available on request

## PRODUCT DIMENSION

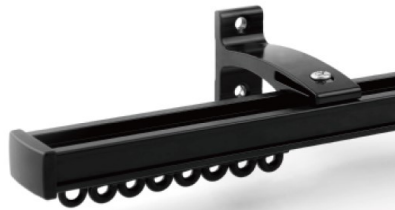
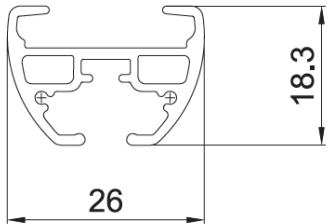

## Mount on ceiling - single track instruction

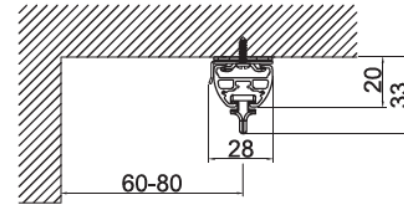

## Mount on ceiling - double track instruction

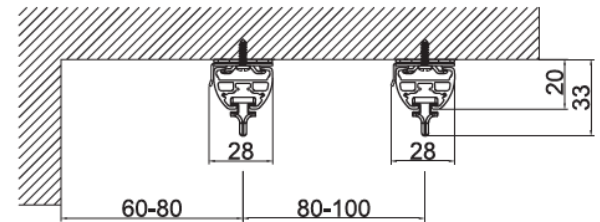

## Mount on wall - single track instruction

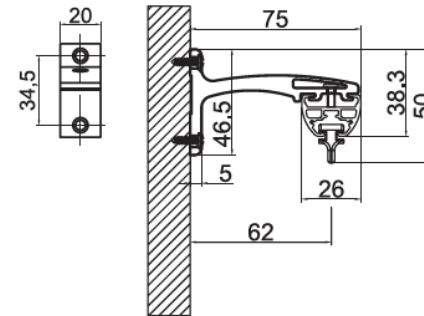

## Mount on wall - double track instruction

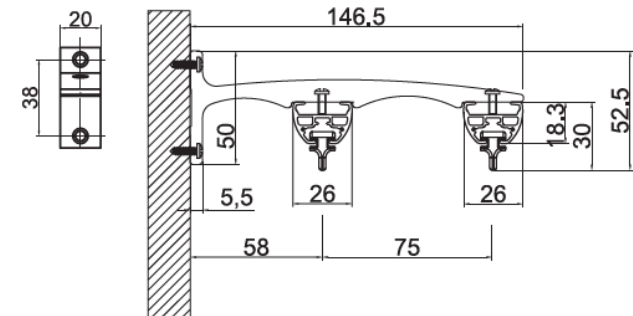

# 6300 / 6400 SERIES –





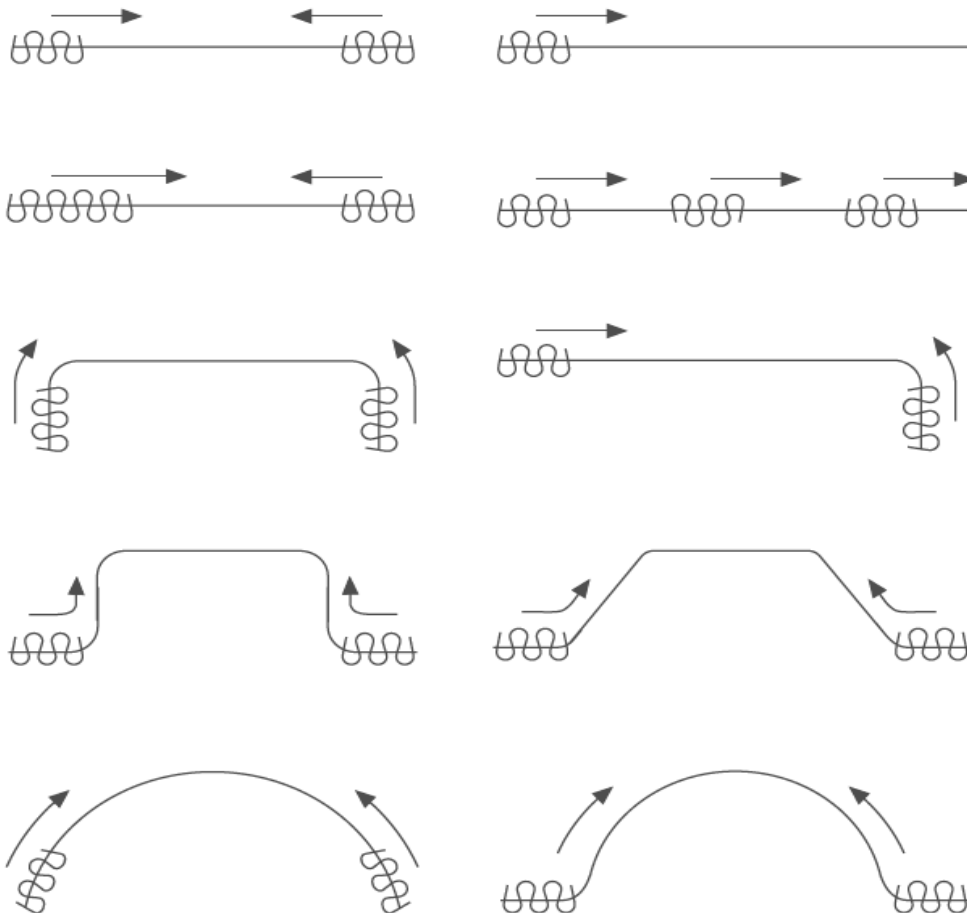

highly efficient hand drawn system for light to medium weight draperies

## BENDING & CURVING

The track can be curved and reversed curved using a 10 cm (4") radius. Additionally there is a curving possibility for special windows like arches, bows and circles. Bending instructions available on request.

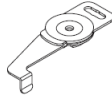
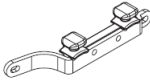

## 6400 / 6300 ACCESSORIES

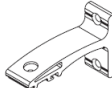
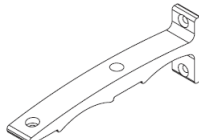
-  end stop carrier with cap
-  symmetrical carrier a
-  symmetrical carrier b
-  symmetrical carrier c
-  end stop carrier
-  ceiling bracket
-  master overlap carrier
-  master magnetic carrier
-  wall bracket single
-  wall bracket double





**5500 MAGNATIC / 5600 OVERLAP  
CURTAIN TRACK SYSTEM**

# 5500 MAGNETIC -

magnetic and silent hand drawn system  
for **medium to heavy** weight draperies



## COLORWAYS

5500-01      BLACK MATT



5500-02      IVORY WHITE



# 5500 MAGNETIC -

magnetic and silent hand drawn system for **medium to heavy** weight draperies

## PRODUCT INFORMATION

- Track finish: 6063-T5 aluminium with electrophoretic coating
- Dimension: 28 mm x 17.5 mm
- Thickness: 1.9 mm aluminum extrusion
- Weight capacity: 8-10 kg per meter
- Durability: able to run over 5000 times with 4kg on each carrier
- Bendable: it can be bent and reversed bent using a 10 cm (4") radius or continuous curve, available on request
- Suitable for special window decoration as circular, arch and triangle window models
- Special colors: available on request

## PRODUCT DIMENSION

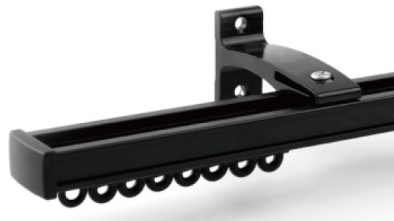
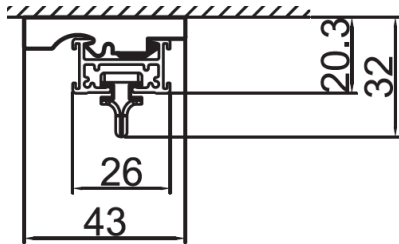

## Mount on ceiling - single track instruction

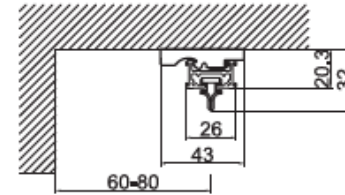

## Mount on ceiling - double track instruction

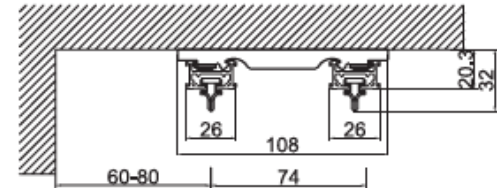

## Mount on wall - single track instruction

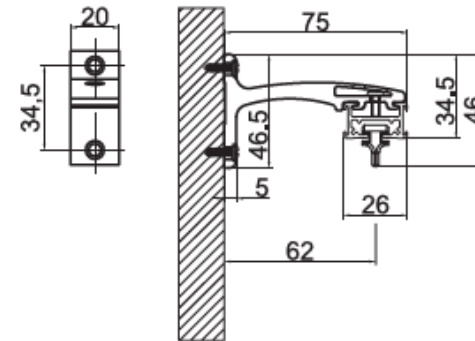

## Mount on wall - double track instruction

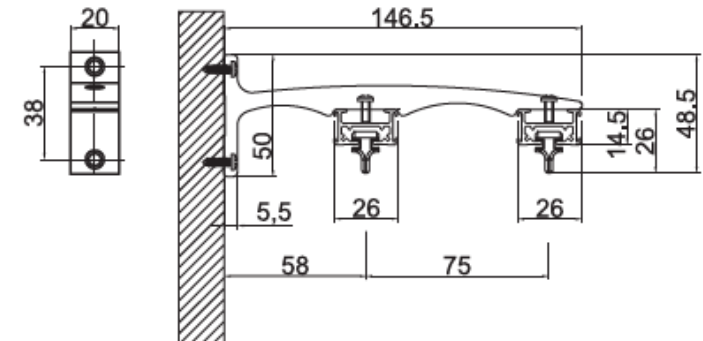

# 5600 OVERLAP -

highly efficient hand drawn system for medium to heavy weight draperies



## COLORWAYS

5600-01 BLACK MATT



5600-02 IVORY WHITE



5600-03 NAVY BLUE



5600-04 CHAMPAGNE GOLD



\* two more pleats are suggested for overlap carrier  
\* 2.3 - 2.5 times fabric quantity is suggested



# 5600 OVERLAP -

highly efficient hand drawn system for **medium to heavy** weight draperies

## PRODUCT INFORMATION

- **Track finish:** 6063-T5 aluminium with electrophoretic coating
- **Dimension:** 28 mm x 17.5 mm
- **Thickness:** 1.9 mm aluminum extrusion
- **Weight capacity:** 8-10 kg per meter
- **Durability:** able to run over 5000 times with 4kg on each carrier
- **Bendable:** it can be bent and reversed bent using a 10 cm (4") radius or continuous curve, available on request
- **Suitable for special window decoration** as circular, arch and triangle window models
- **Special colors:** available on request

## PRODUCT DIMENSION

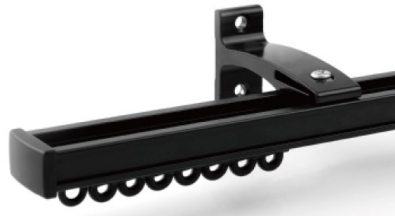
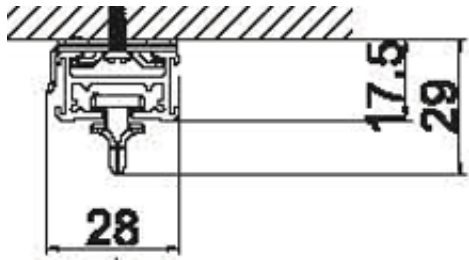

## Mount on ceiling - single track instruction

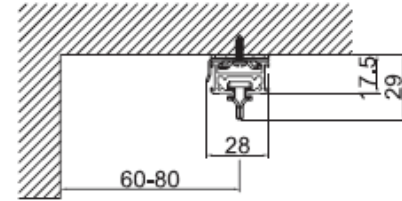

## Mount on ceiling - double track instruction

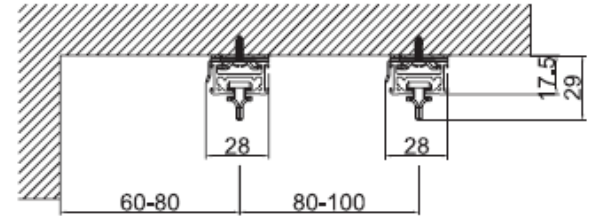

## Mount on wall - single track instruction

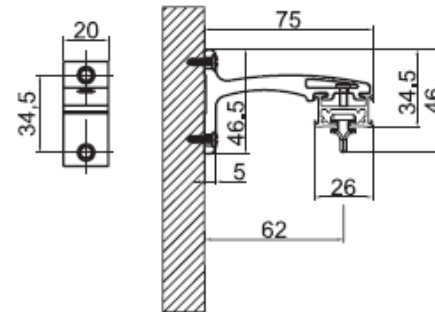

## Mount on wall - double track instruction

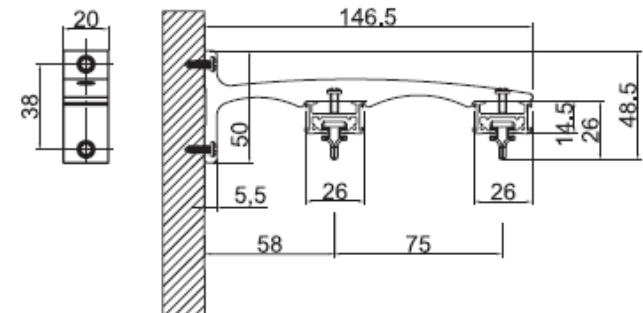

# 5500 / 5600 SERIES –

highly efficient hand drawn system for **medium to heavy** weight draperies

## BENDING & CURVING

The track can be curved and reversed curved using a 10 cm (4") radius. Additionally there is a curving possibility for special windows like arches, bows and circles. Bending instructions available on request.

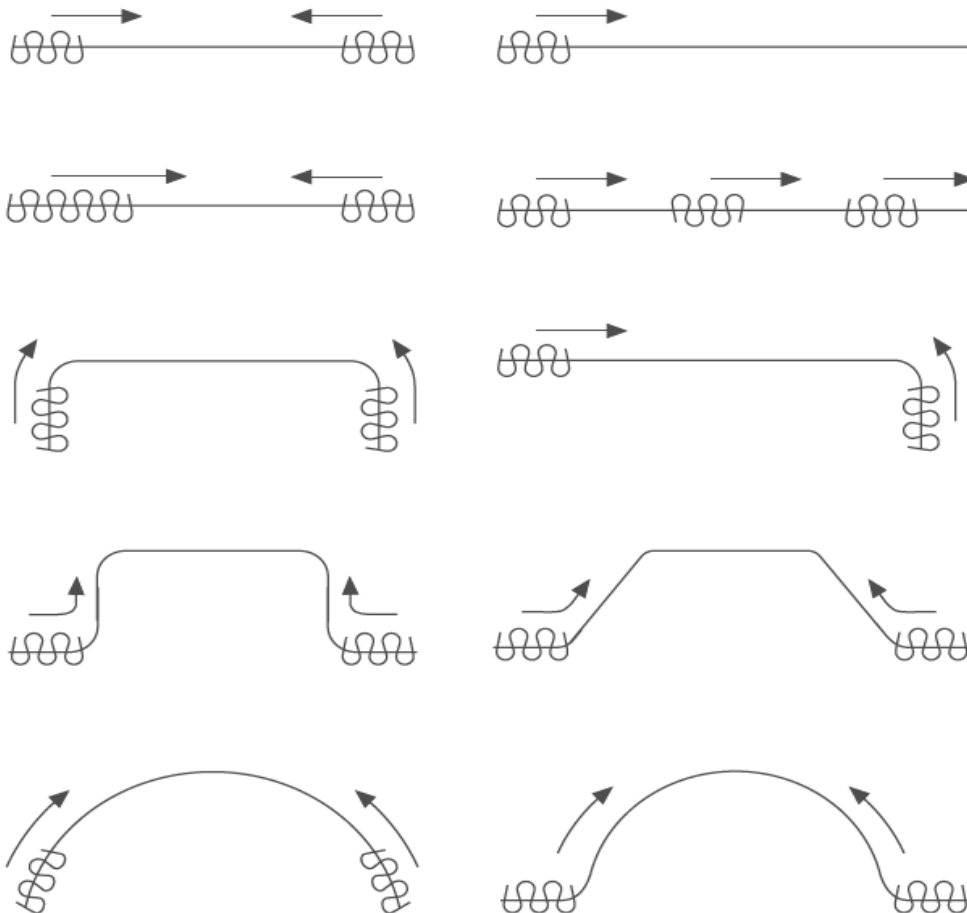

## 5600 / 5500 ACCESSORIES

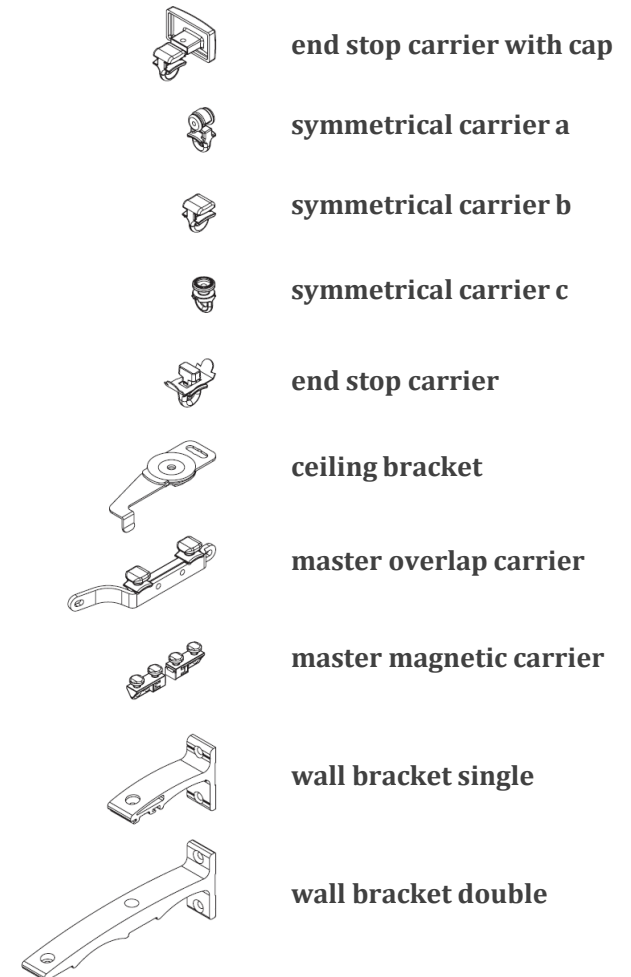



**2700 RIPPLE FOLD  
S WAVE CURTAIN TRACK**

## 2700 RIPPLE FOLD -

ripple fold hand drawn system for  
**light to medium** weight draperies



### COLORWAYS

**2700-01**  
**IVORY WHITE**

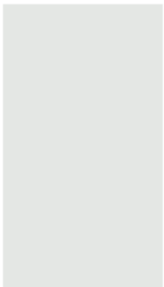

**2700-02**  
**BLACK MATT**





# 2700 RIPPLE FOLD –

ripple fold hand drawn system for **light to medium** weight draperies

## PRODUCT INFORMATION

- **Track finish:** 6063-T5 aluminium with electrophoretic coating
- **Dimension:** 20 mm x 178.6 mm
- **Thickness:** 1.4 mm aluminum extrusion
- **Weight capacity:** 8-10 kg per meter
- **Durability:** able to run over 5000 times with 4kg on each carrier
- **Bendable:** it can be bent and reversed bent using a 10 cm (4") radius or continuous curve, available on request
- **Suitable for special window decoration as circular, arch and triangle window models**
- **Special colors:** available on request
- **The track can be embedded on ceiling per dimensions, be careful to measure the distance for the wave finish**

## PRODUCT DIMENSION

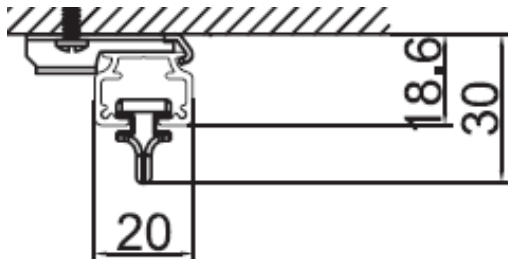

## RIPPLE FOLD ACCESSORIES



curtain hooks



base roller

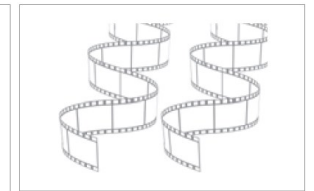

wave tape



# 2700 RIPPLE FOLD –

ripple fold hand drawn system for  
**light to medium** weight draperies

## \* HOW TO MEASURE INTERVAL DISTANCE

Formula:  $(6 \times \text{fabric quantity}) + 1 \text{ cm}$

### Example:

If fabric quantity is 2, interval is suggested to be  $(6 \times 2) + 1 = 13 \text{ cm}$

If fabric quantity is 2.5, interval is suggested to be  $(6 \times 2.5) + 1 = 16 \text{ cm}$

### 1-1/ Mount on ceiling – single ripple fold drapery

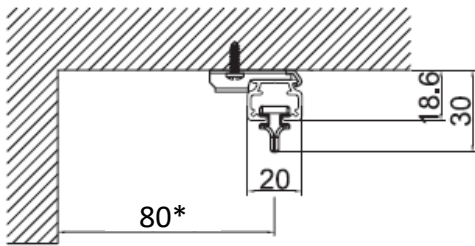

### 1-2/ Mount on ceiling – double ripple fold drapery

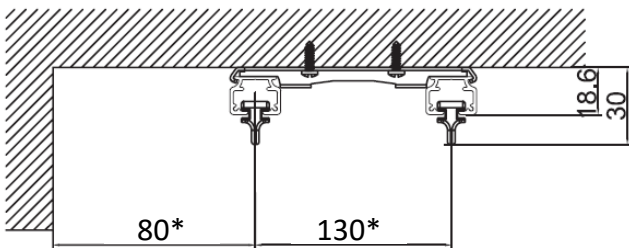

### 1-3/ Mount on ceiling – pleat sheer with ripple fold drapery

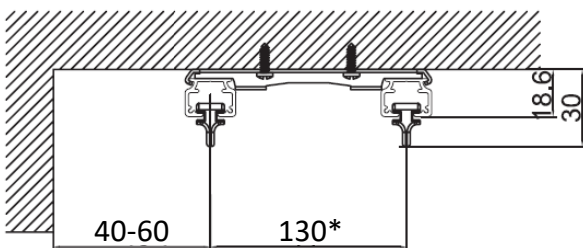

## 2/ Embedded Drapery Track Instruction

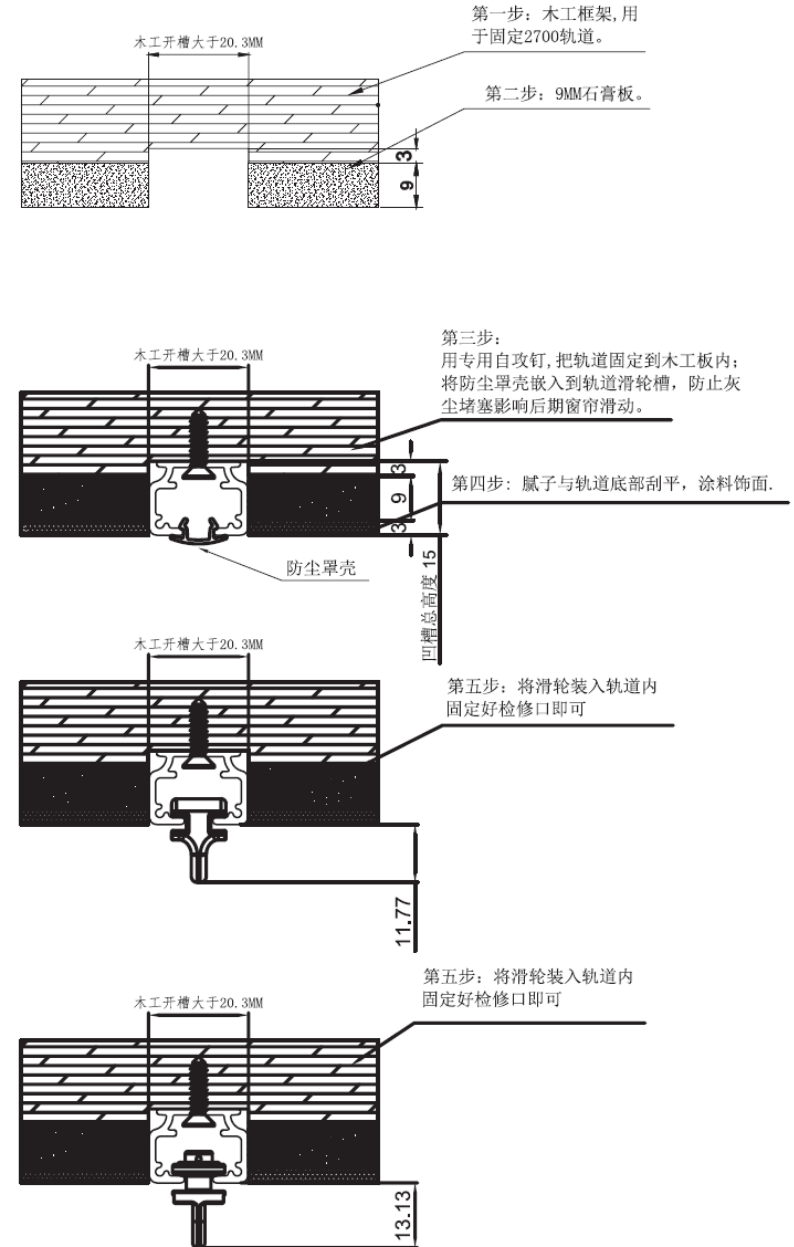

\* 4200 manual bending track is suggested for ceiling requires a special curve or shape, the track can be bent on-site



## **4200 MANUAL BENDING CURTAIN TRACK**

# 4200 MANUAL BENDING –

flexible and easy to adjust hand drawn system  
for **light to medium** weight draperies



## PRODUCT INFORMATION

- **Track finish:** 6063-T5 aluminium with electrophoretic coating
- **Dimension:** 13.2 mm x 18 mm
- **Thickness:** 1.2 mm aluminum extrusion
- **Weight capacity:** 6-8 kg per meter
- **Durability:** able to run over 5000 times with 4kg on each carrier
- **Bendable:** it can be bent and reversed bent according to site condition manually
- **Suitable for special window decoration** as circular, arch and triangle window models
- **Special colors:** available on request

## COLORWAYS

4200-02 BLACK MATT



4200-01 IVORY WHITE



## PRODUCT DIMENSION

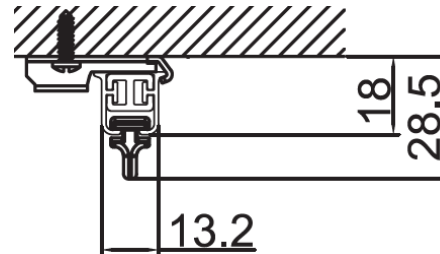



# 4200 MANUAL BENDING -

flexible and easy to adjust hand drawn system for **light to medium** weight draperies



## 4200 ACCESSORIES

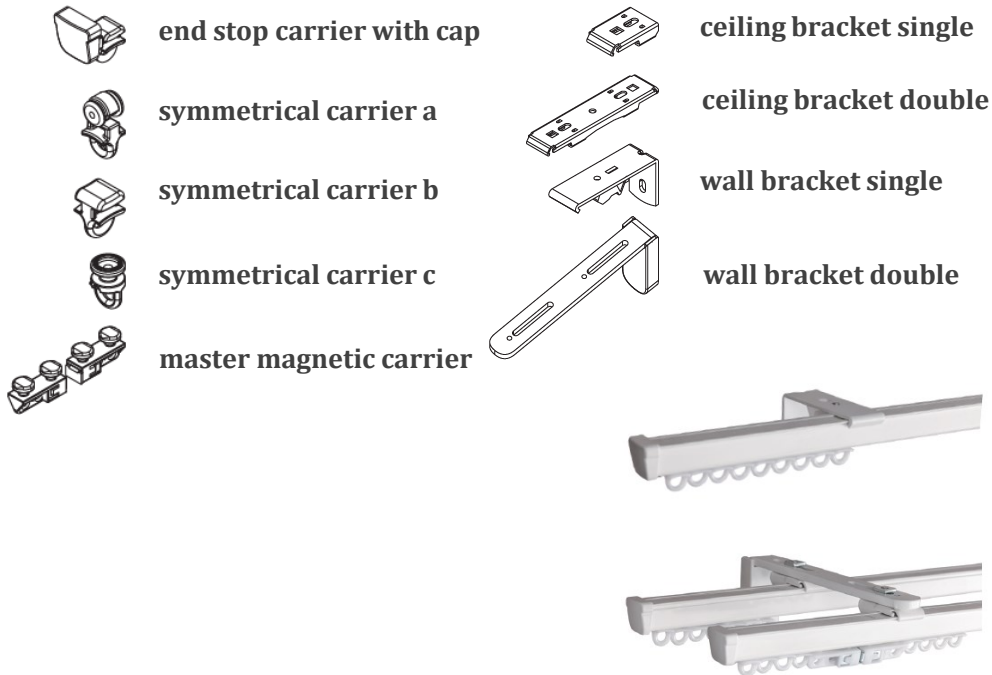

Mount on ceiling - single track instruction

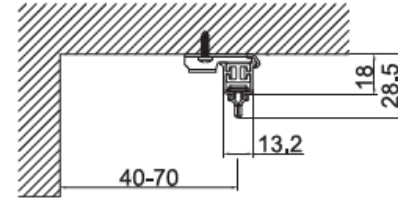

Mount on ceiling - double track instruction

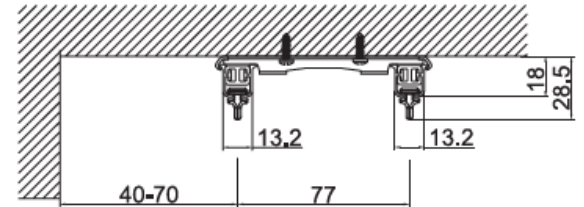

Mount on wall - single track instruction

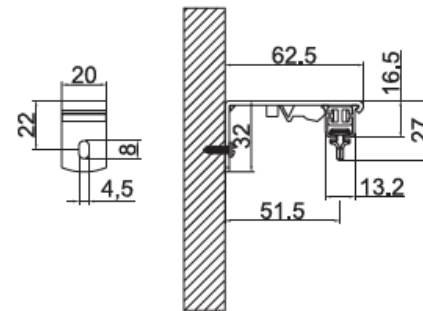

Mount on wall - double track instruction

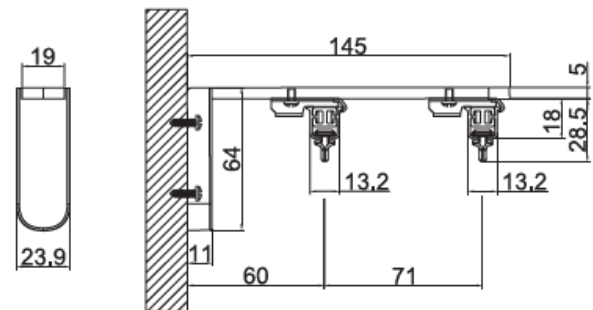



**4300 CEILING EMBEDDED  
CURTAIN TRACK**

# 4300 EMBEDDED TRACK –

invisible ceiling embedded hand drawn system  
for **medium to heavy** weight draperies

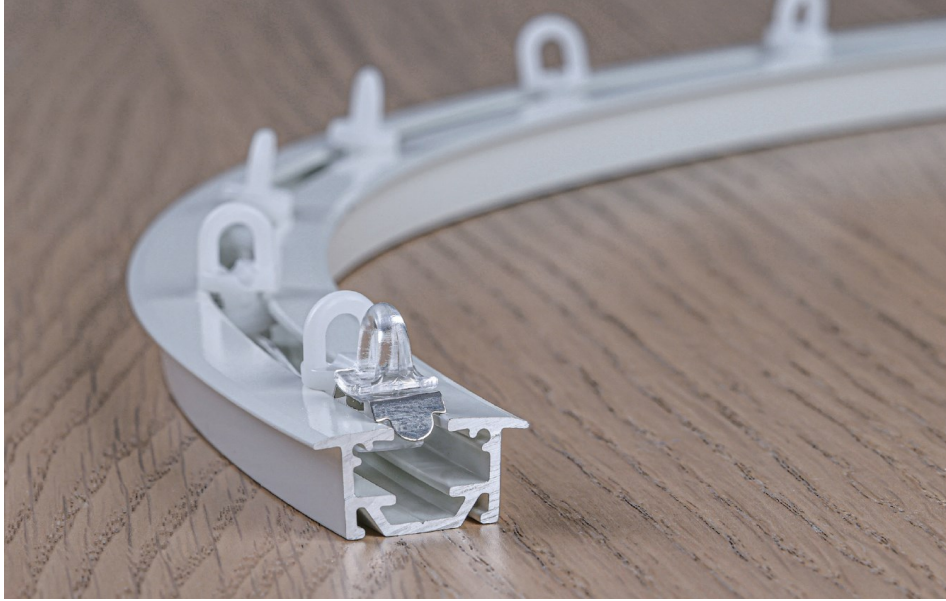

## PRODUCT INFORMATION

- **Track finish:** 6063-T5 aluminium with electrophoretic coating
- **Dimension:** 27 mm x (14.5 mm + 12 mm)
- **Thickness:** 1.4 mm aluminum extrusion
- **Weight capacity:** 15 kg per meter
- **Durability:** able to run over 5000 times with 4kg on each carrier
- **Bendable:** it can be bent and reversed bent using a 10 cm (4") radius or continuous curve, available on request
- **Suitable for special window decoration as circular, arch and triangle window models**
- **Special colors:** available on request

## COLORWAYS

**4300-01**  
**IVORY WHITE**

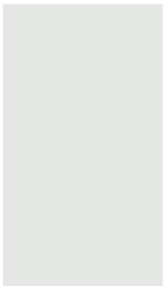

**4300-02**  
**BLACK MATT**



## PRODUCT DIMENSION

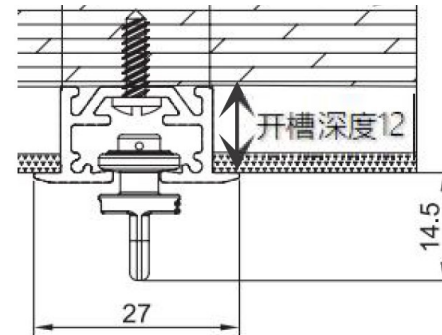





## **CURTAIN RODS COLLECTION**



# VANDEN 27 GOLD -

premium hand drawn rod system for  
**light and medium** weight curtains

## COLORWAYS

Vanden 2705 Gold Color



Vanden 2706 Gold Color



Vanden 2707 Gold Color



Vanden 2708 Gold Color



Vanden 2716 Gold Color

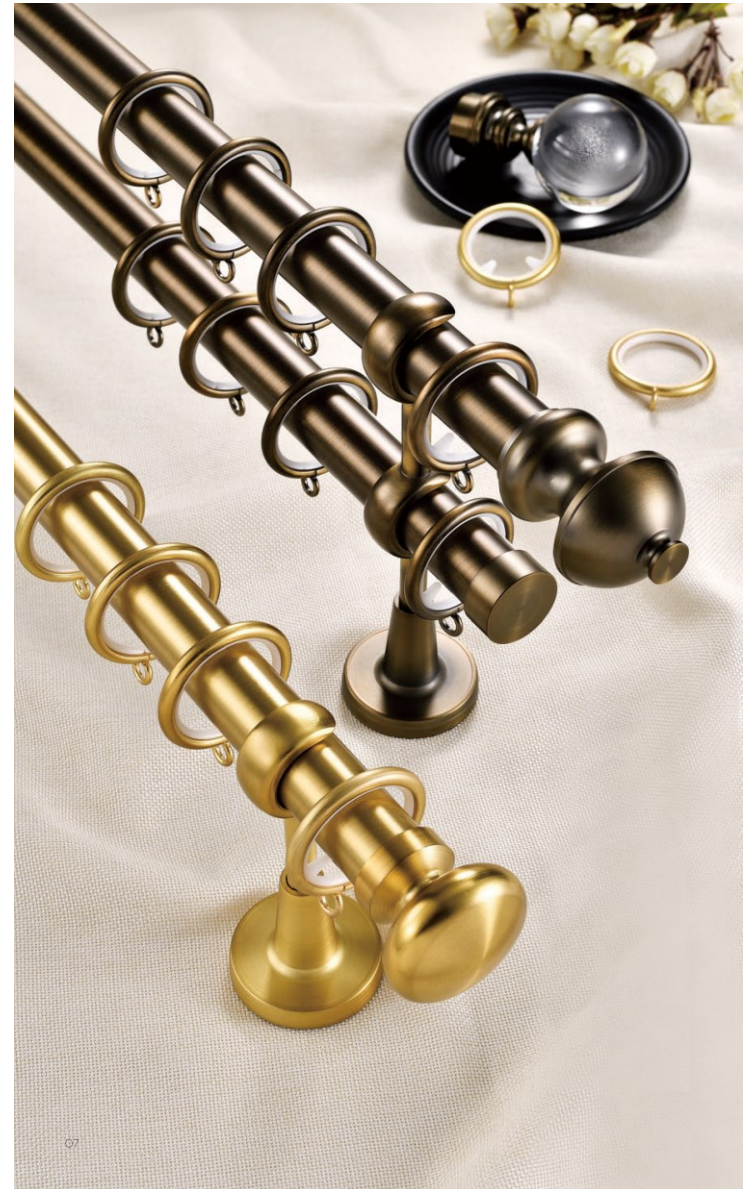

# VANDEN 27 BRONZE -

premium hand drawn rod system for  
**light and medium** weight curtains

## COLORWAYS

Vanden 2709

Bronze Color



Vanden 27010

Bronze Color



Vanden 27011

Bronze Color



Vanden 27012

Bronze Color





# VANDEN 27 SERIES -

premium hand drawn rod system for  
**light, medium and heavy** weight curtains

## PRODUCT INFORMATION

- **Track finish:** 6063-T5 aluminium with electroplating coating
- **Dimension:** 27.4 mm diameter
- **Thickness:** 1.85 mm aluminum extrusion
- **Weight capacity:** 5-8 kg per meter
- **Durability:** able to run over 5000 times with 4kg on each carrier

## PRODUCT DIMENSION

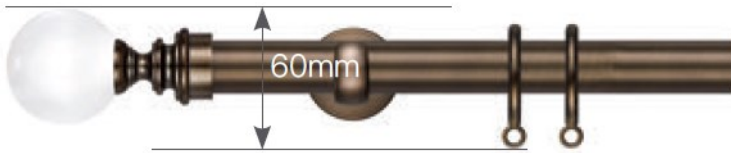

## VANDEN 27 ACCESSORIES



**Stainless Steel  
Rod Hooks**



**Single Track  
Ceiling Bracket**

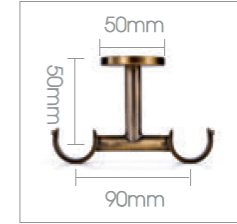

**Double Track  
Ceiling Bracket**

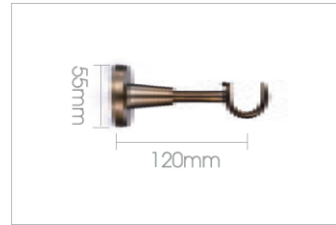

**Single Track  
Wall Bracket**

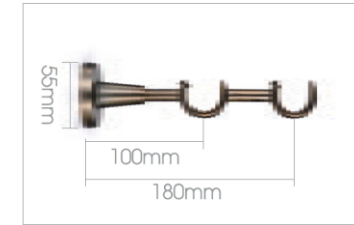

**Double Track  
Wall Bracket**

**Single track -  
mount on ceiling**



**Double track -  
mount on ceiling**



# VANDEN WHITE -

premium hand drawn rod system for  
**light and medium** weight curtains

## COLORWAYS

Vanden 27017 White Color



Vanden 270218 White Color



Vanden 270219 White Color



Vanden 27020 White Color



Vanden 2201 White Color



Vanden 2202 White Color



Vanden 2203 White Color





# VANDEN BLACK -

premium hand drawn rod system for  
**light and medium** weight curtains

## COLORWAYS

Vanden 27021 Black Color



Vanden 27022 Black Color



Vanden 27023 Black Color



Vanden 27024 Black Color



Vanden 2204 Black Color



Vanden 2205 Black Color



Vanden 2206 Black Color



# 7500 SERIES -

premium minimalist style hand drawn system for **light, medium to heavy** weight draperies

## PRODUCT INFORMATION

- Track finish: 6063-T5 aluminium with electrophoretic coating
- Dimension: 16 mm x 50 mm
- Thickness: 2.2 mm aluminum extrusion
- Weight capacity: 8-20 kg per meter
- Durability: able to run over 5000 times with 4kg on each carrier
- Special colors: available on request



## PRODUCT DETAILS

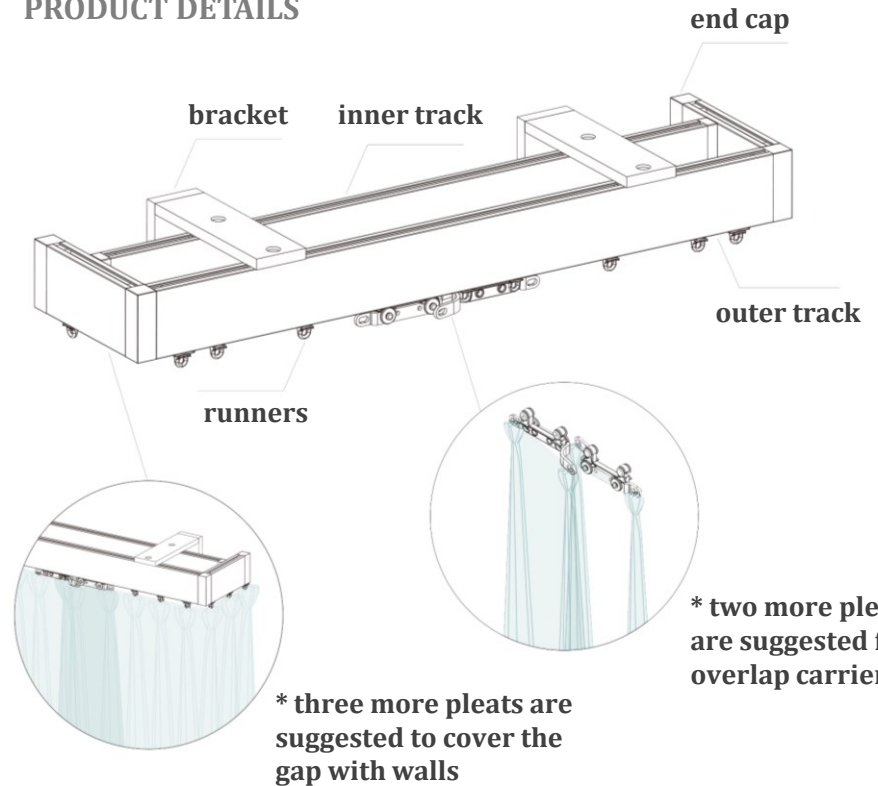

## COLORWAYS

7500-01  
BLACK

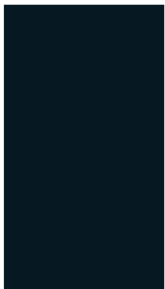

7500-02  
SILVER

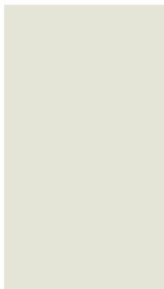

7500-03  
CHAMPAGNE



# 7500 SERIES -

premium minimalist style hand drawn system for  
**light, medium to heavy weight draperies**



**Mount on ceiling - single track instruction**

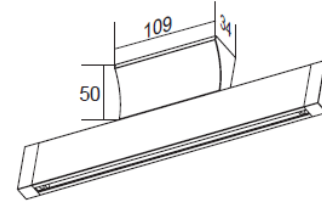

**Mount on ceiling - double track instruction**

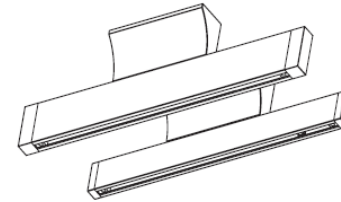

**Mount on wall - single track instruction**

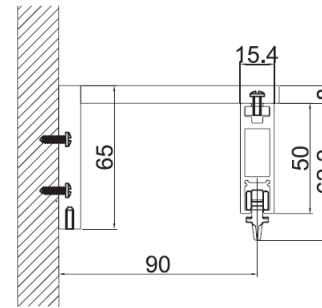

**Mount on wall - double track instruction**

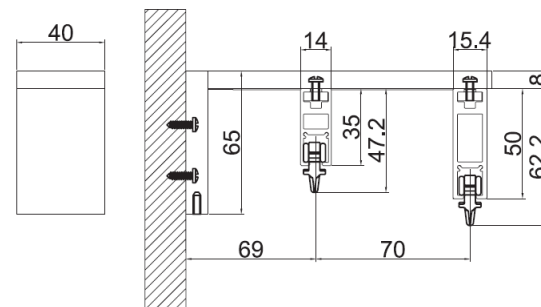

## PRODUCT DIMENSION

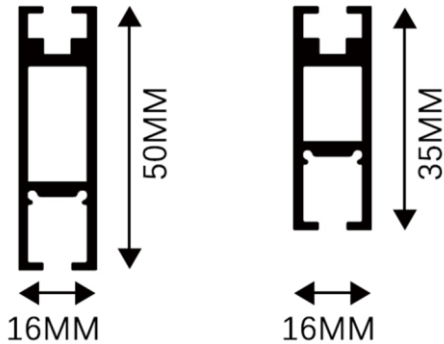



**CONTACT US FOR SAMPLES!**

For latest update:  
[www.yorklon.en.alibaba.com](http://www.yorklon.en.alibaba.com)  
[www.yorklonltd.com](http://www.yorklonltd.com)