

Oil-Injected Screw Air Compressor

OPERATION & MAINTENANCE & INSTALLATION MANUAL

Introduction

This manual introduces the working principle and main structure of screw air compressor. In order to enable our users to make full use of products, we make our efforts to provide operators with abundant information, functions, operation and maintenance of air compressor.

Before the first installation and startup of the compressor, please read the manual carefully, so as to acquire the knowledge on operation and maintenance. If any items missed in this manual, please feel free to contact service department, who are ready to help you at any time.

CONTENTS

Chapter 1 Brief introduction of screw air compressor.....	1
1. Summary of screw air compressor	1
2. Body structure of screw air compressor	1
2.1 Basic structure	1
2.2 Meshing	1
3. The compression principle of screw air compressor.....	1
3.1 Suction process	1
3.2 Compression and injection process	2
3.3 Discharge process	2
Chapter 2 Exterior drawing	3
Chapter 3 Installation.....	11
1. Installation	11
2. Air circulation	11
3. Installation of inlet pipe	11
4. Cooling water volume of screw air compressor.....	11
Chapter 4 System flow of air compressor and function of parts.....	13
1. Brief introduction	13
2. Transmission system	13
3. Inlet and exhaust system	13
4. Function description of main parts.....	13
4.1 Air Filter	13
4.2 Air intake valve	13
4.3 Compressor air end	14
4.4 Oil/Air Separator tank	14
4.5 Safety valve	14
4.6 High precision oil/air separation element.....	15
4.7 Minimum Pressure Valve	15
5. Cooling and lubricating system	15
5.1 System flow	15
5.2 Function description of main parts	15
5.2.1 Lubricate oil	15
5.2.2 Oil cooler	16
5.2.3 Oil Filter	16
5.2.4 Cooling Fan	16
5.3 Control system and electrical circuit	16
5.3.1 Motor start(lower voltage or Y start).....	16
5.3.2 Start delta conversion(motor full voltage operation) and loading.....	16
5.3.3 Heavy load / empty load operation	16
5.3.4 Shut down	17

5.3.5 Emergency shutdown	17
5.3.6 Electrical circuit and cables	17
Chapter 5 Operation and use	19
1. Safety operation regulations	19
2. Inspection of the rotary direction of the compressor.....	19
3.Start	19
4. Normal operation	20
5.Shut down	20
6.Attentions of the running	20
Chapter 6 Maintenance and Repairs	21
1. Brief introduction	21
2. Daily maintenance	21
3. Belt adjustment (Belt driven air compressor).....	21
4. Replacement and adjustment of parts	22
4.1 Maintenance of air filter	22
4.2 Maintenance of oil filter	22
4.3 Maintenance of oil/air separation element.....	22
5.Discharge condensate	23
6.Replace the lubricate oil	23
7.Fill new oil according to the following steps	24
8.Compressor oil supplement	24
9.Compressor lubricate oil	24
Chapter 7 Fault analysis and troublesjooting.....	27
Chapter 8 Storage requirements	31
1. Safety attentions	31
2. Maintenance and repairs	32
To user	33

Chapter 1 Brief introduction of screw air compressor

1. Summary of screw air compressor

Oil-injected screw air compressor has the characteristics of high reliability, less wearing parts, good dynamic balance, small vibration, low noise and high efficiency. During the compress process, the lubricating oil is continuously injected into the compression chamber and the bearings by means of the pressure difference generated by itself.

This design has the following characteristics:

1.1 The injected lubricant can form oil film between the rotors, and the negative rotor can be driven directly by the positive rotor and play the role of sealing.

1.2 Lubricant oil can reduce the noise generated by high frequency compression.

1.3 Lubricant oil can absorb a large amount of compression heat.

2. Structure of screw air compressor

2.1 Basic structure

The oil injected screw air compressor is a kind of rotary compressor, and a pair of positive and negative rotors is located inside the airend.

2.2 Meshing

Because the two rotors are inter-meshed with each other, the positive rotor directly drives the negative rotor to rotate together. The cooling lubricant oil is sprayed directly into the inter-meshed portion of the rotors through the nozzle from the lower part of the airend, the cooling effect can be reached through mixed with air, take away heat generated due to compression. At the same time, the oil film is formed to prevent direct contact between the rotors and to close the gap between the rotors and the shell. The injected lubricant oil can also reduce the noise caused by high-speed compression.

3. The compression principle of screw air compressor

3.1 Suction process

The suction port of the screw air compressor is designed to make the compression chamber

fully aspirated, and the intake volume is regulated only by the opening and closing of the intake control valve. When the rotors rotate, the space of the rotor slot is maximum when it turns to the opening of inlet side. At this time the slot space of the rotor is connected to the free air of the inlet, because the air in the rotor slots is completely discharged when the exhaust finish. When the exhaust is over, the rotor slot is in a vacuum state, and when the rotor slot turns to the inlet port, the outside air is inhaled and along the axis. And the air fills the slot completely with the rotation of the rotors, inter-mesh gradually complete until the air is closed completely well between the meshing line and closed slots.

3.2 Compression and injection process

As the rotors continue to rotate, the meshing lines of the closing chamber composed of the positive rotor and negative rotor and the casing of the airend move to the exhaust end, that is, the slot volume between the meshing line and the discharge port gradually decreases, and the air in it is gradually compressed, and the pressure gradually increases. At the same time, the lubricating oil is injected into the compression chamber and mixed with the air.

3.3 Discharge process

When the meshing end faces of the rotors are connected to the exhaust port of the airend, the pressure of the compressed air reaches the highest, the mixed air with the lubricating oil is discharged until the rotor slots are completely separated from the exhaust port. At this time the rotor slot volume is zero and the exhaust is finished, and the new round of suction, compression and exhaust will be repeated.

Chapter 2 Exterior drawing

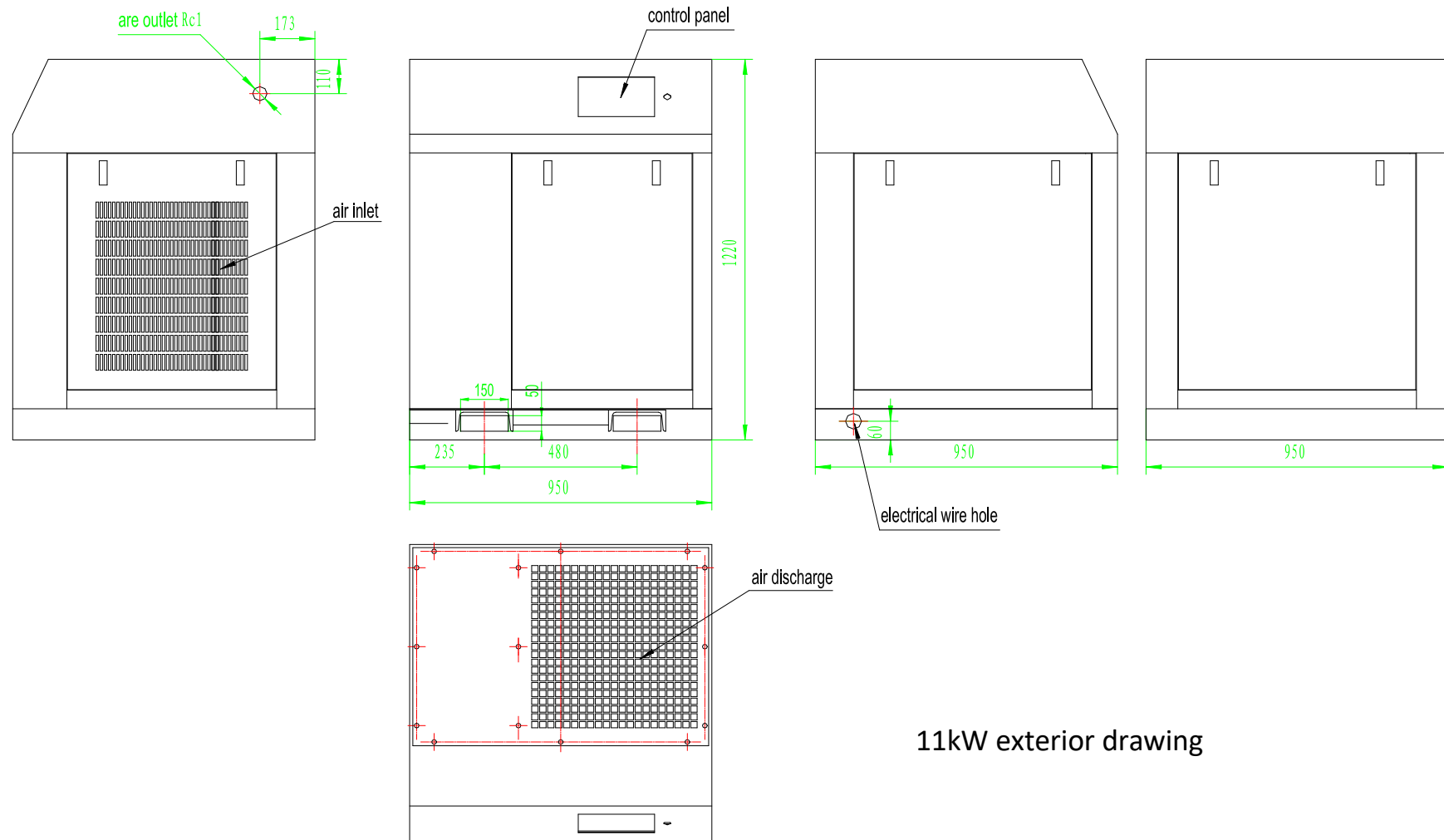

11kW exterior drawing

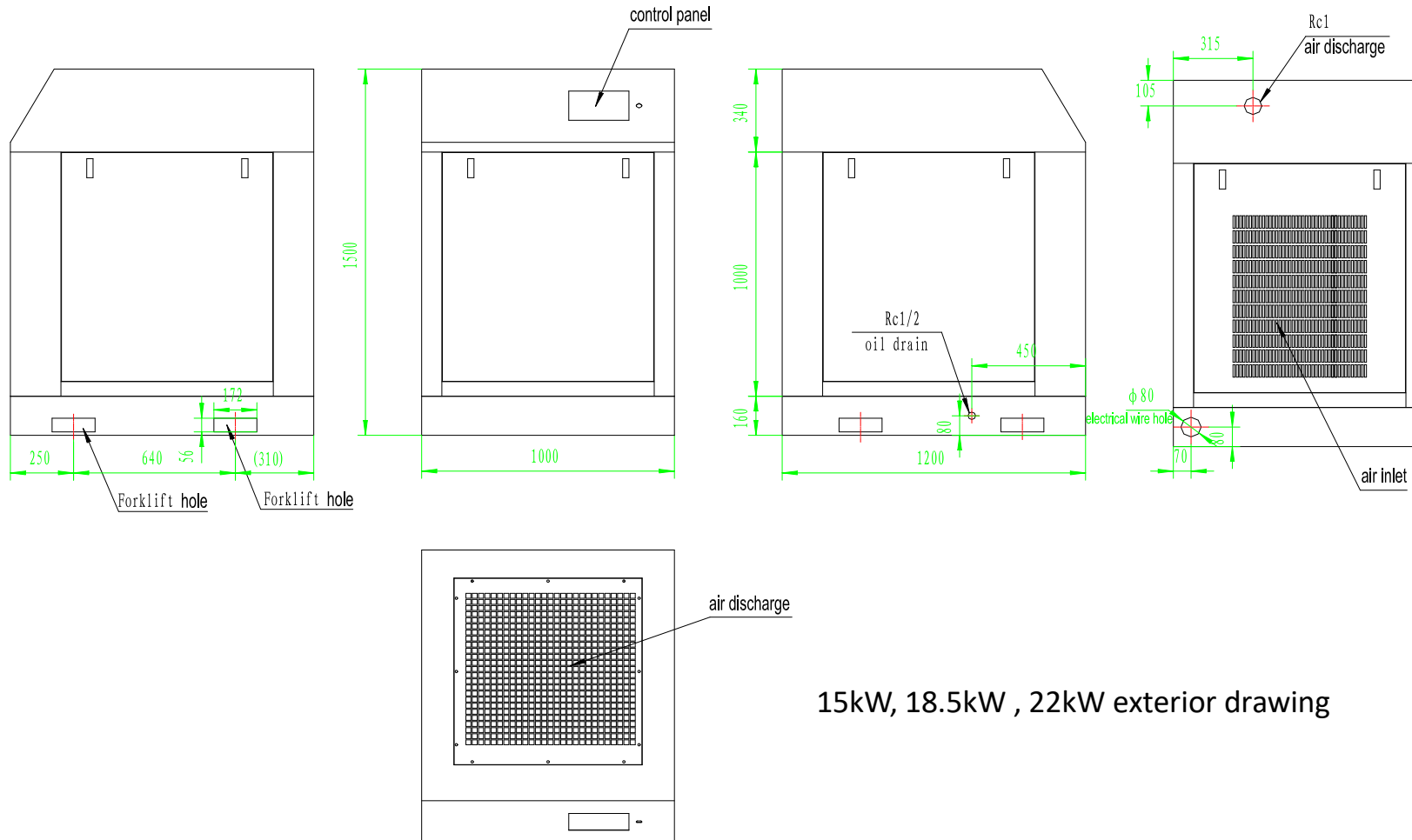

15kW, 18.5kW , 22kW exterior drawing

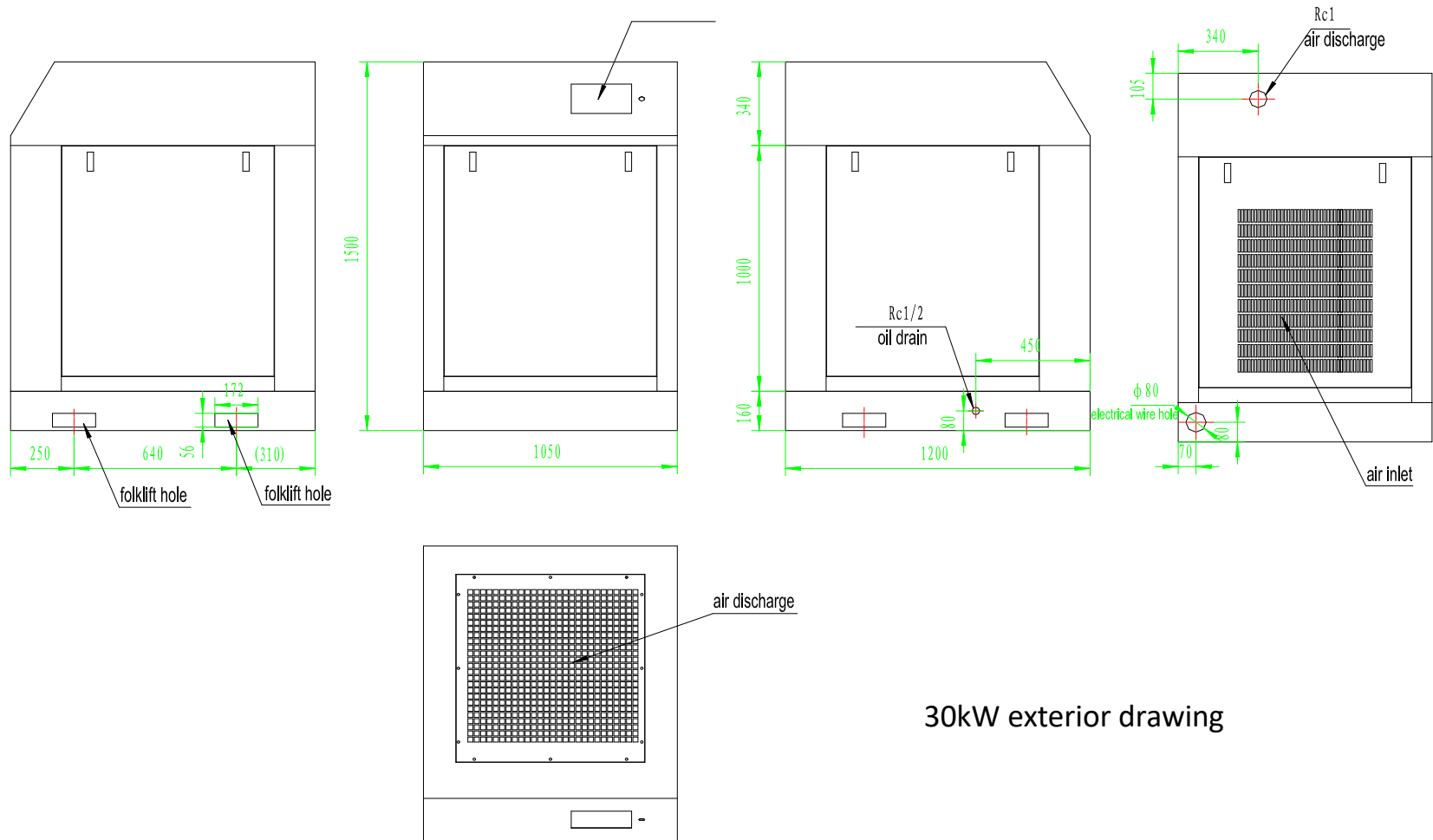

30kW exterior drawing

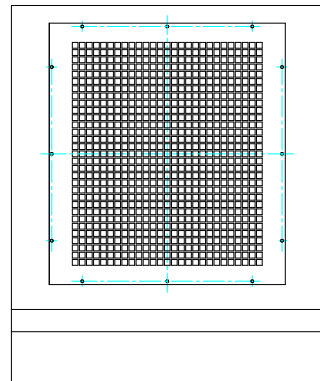
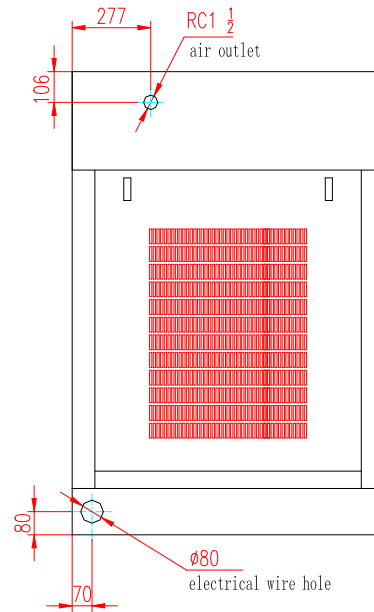
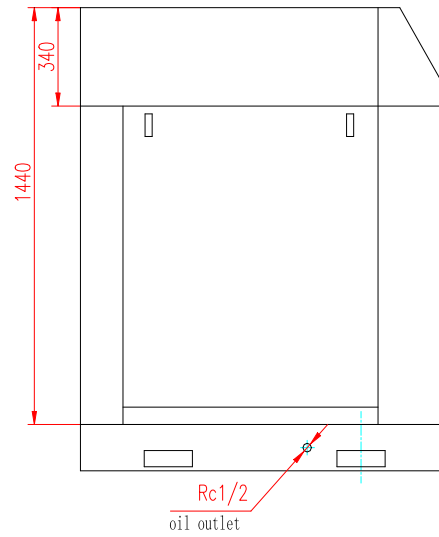
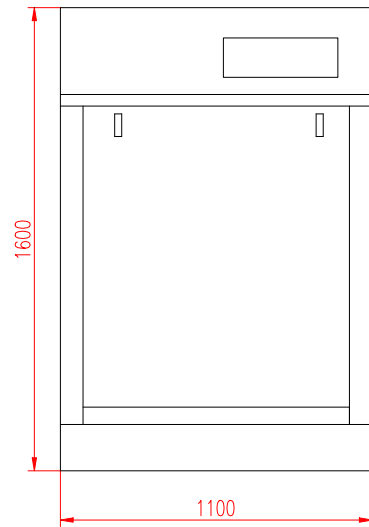
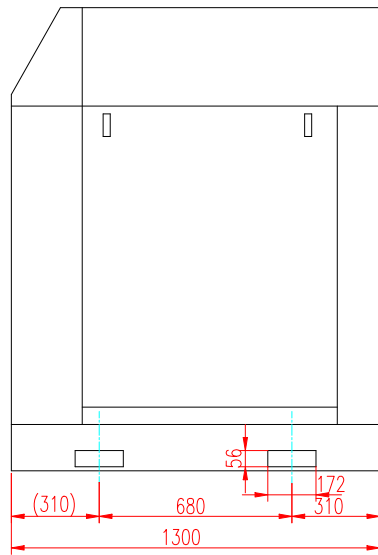

37kW , 45kW exterior drawing

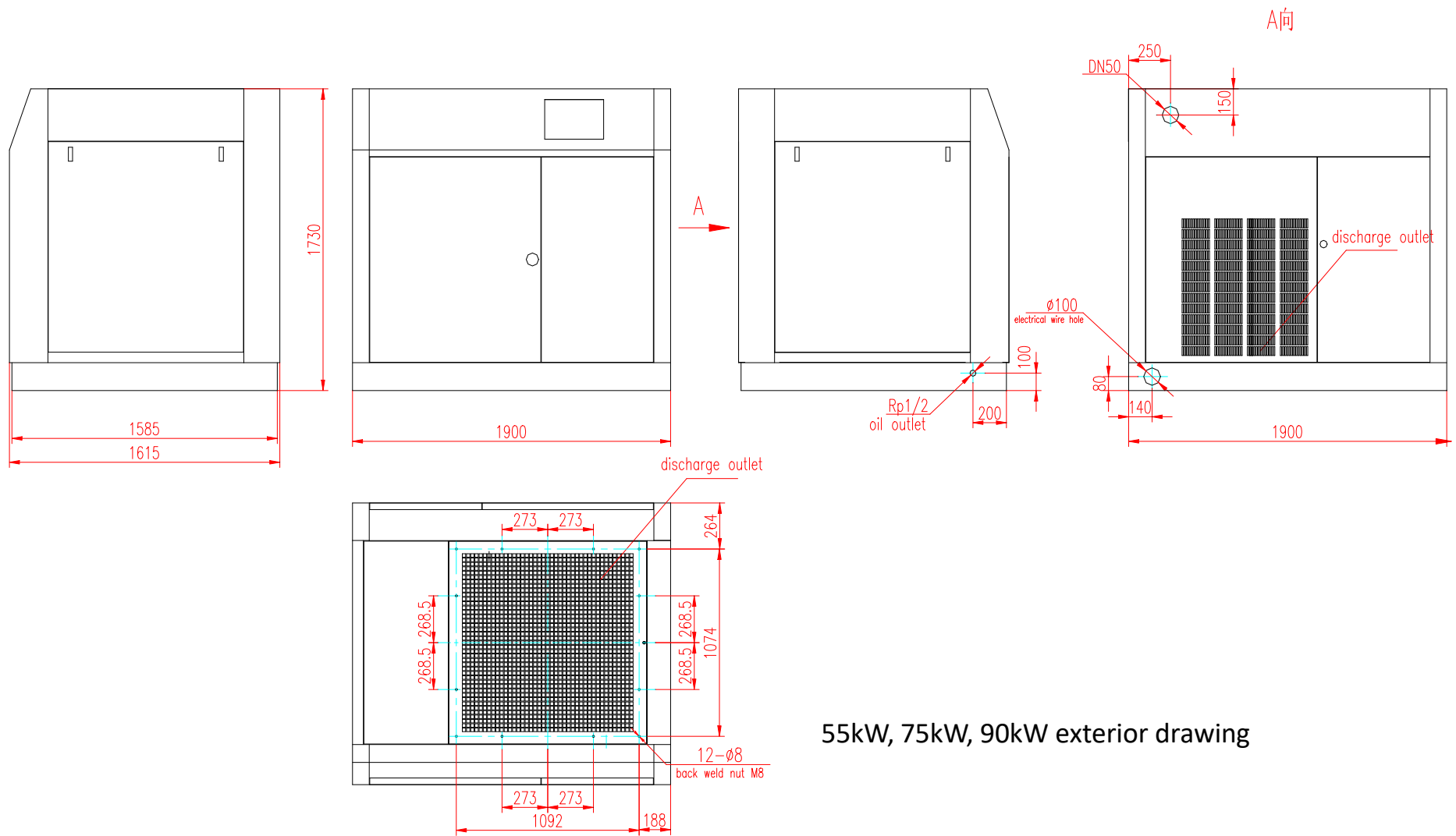

55kW, 75kW, 90kW exterior drawing

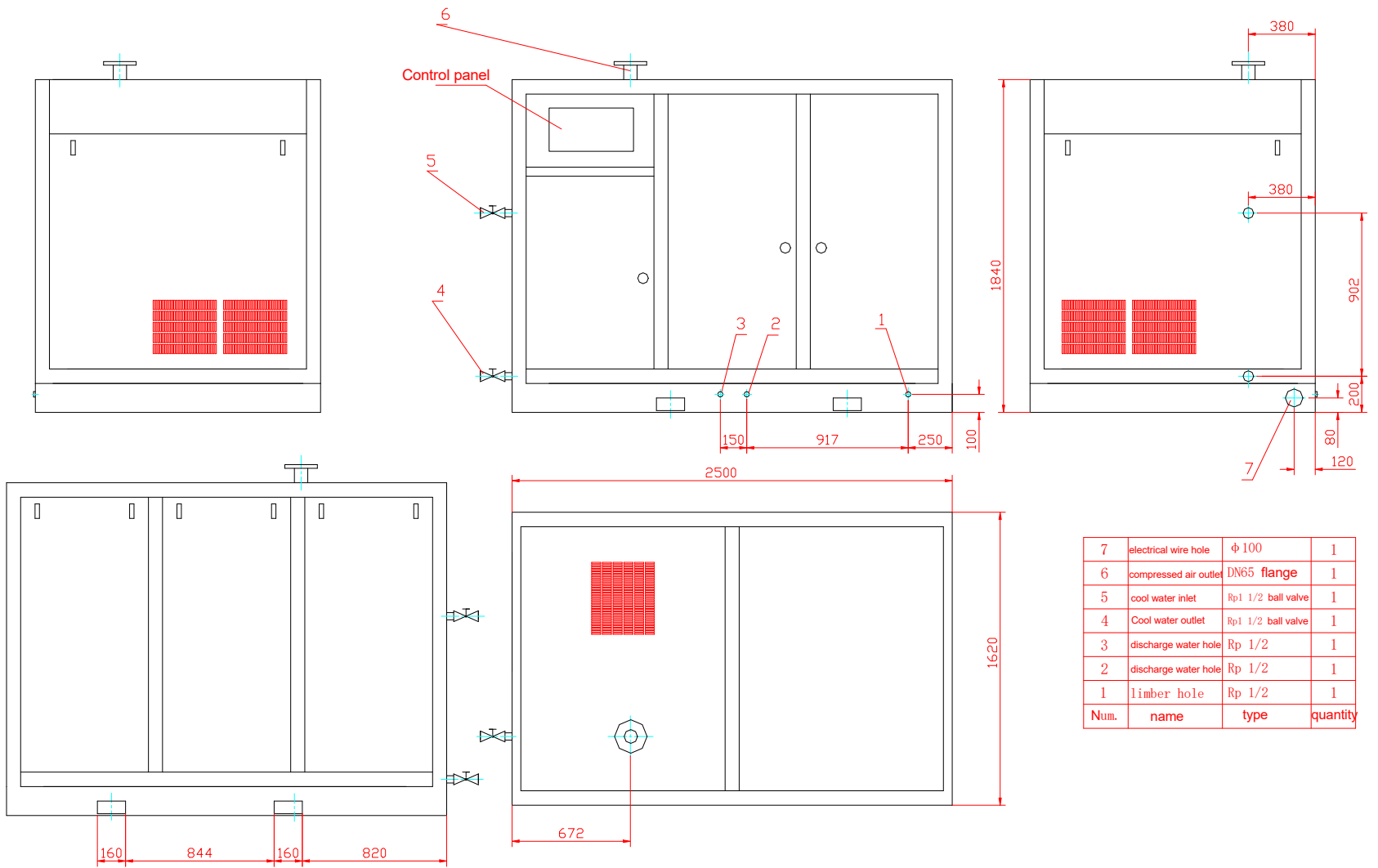

7	electrical wire hole	Φ 100	1
6	compressed air outlet	DN65 flange	1
5	cool water inlet	Rp1 1/2 ball valve	1
4	Cool water outlet	Rp1 1/2 ball valve	1
3	discharge water hole	Rp 1/2	1
2	discharge water hole	Rp 1/2	1
1	limber hole	Rp 1/2	1
Num.	name	type	quantity

back view

110kW, 132kW exterior drawing

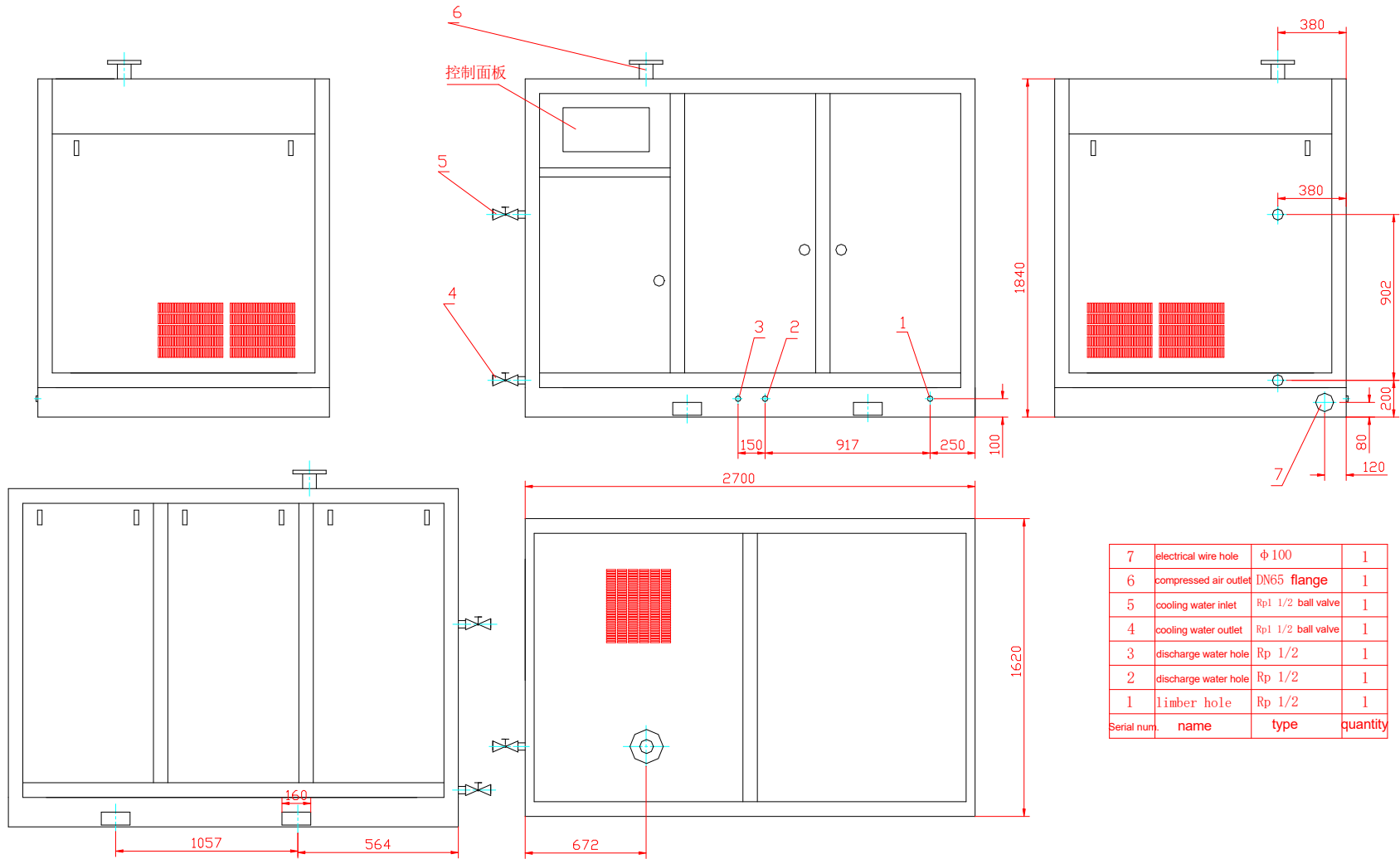

7	electrical wire hole	Φ100	1
6	compressed air outlet	DN65 flange	1
5	cooling water inlet	Rp1 1/2 ball valve	1
4	cooling water outlet	Rp1 1/2 ball valve	1
3	discharge water hole	Rp 1/2	1
2	discharge water hole	Rp 1/2	1
1	limber hole	Rp 1/2	1
Serial num.	name	type	quantity

back view

160kW, 185kW exterior drawing

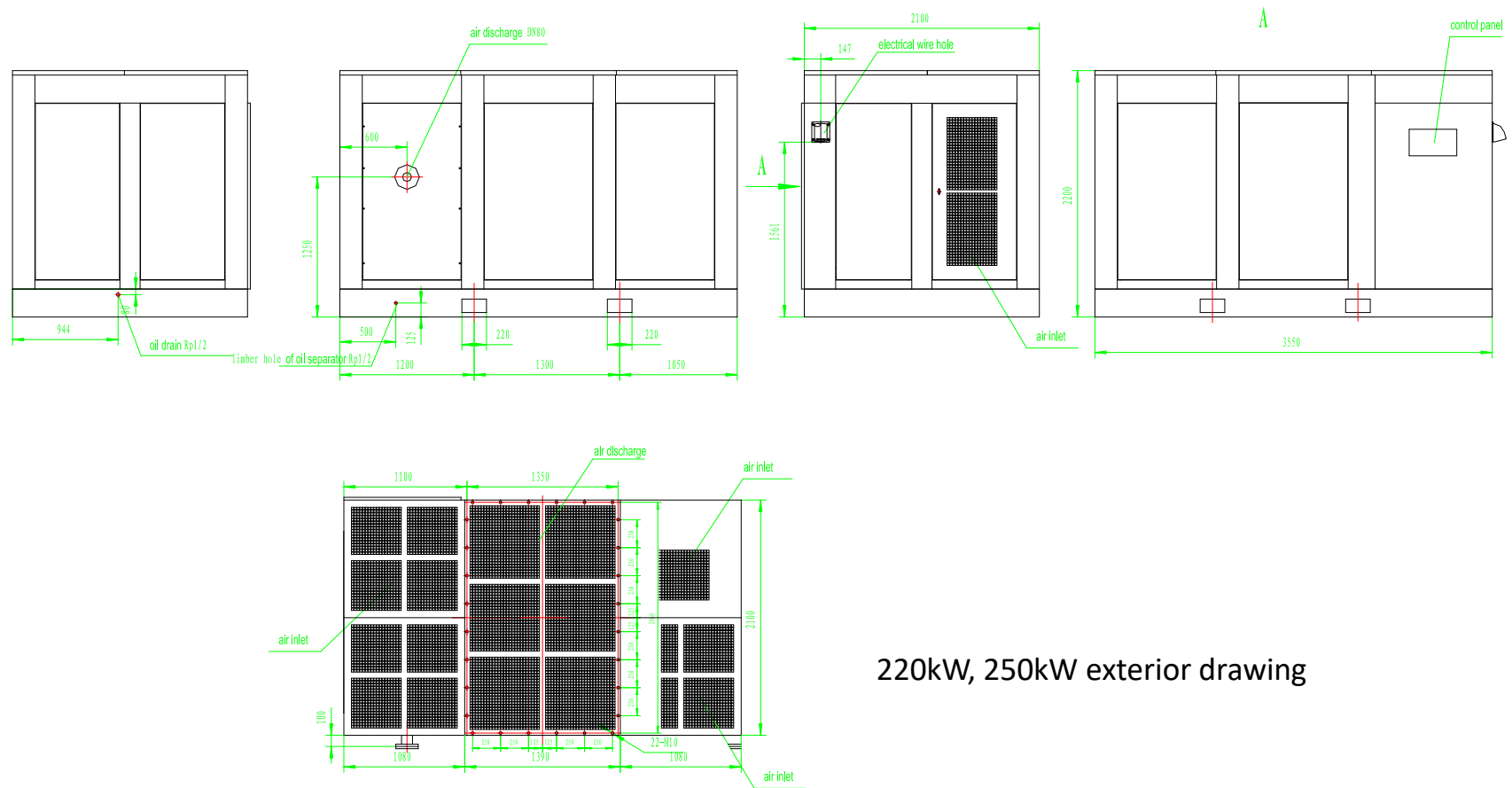

220kW, 250kW exterior drawing

Chapter 3 Installation

1. Installation

The compressor should be placed horizontally on ground.

The ground should be flat to avoid vibration and noise.

2. Air circulation

In order to keep the working temperature of the air compressor stable and ensure the air flow in and out of the compressor freely, we should reserve some space for the suction port and the discharge pipe.

The ambient temperature should be below 45°C. The higher the ambient temperature, the less the air capacity.

3. Installation of inlet pipe

There is a block valve on the inlet pipe of the air compressor. The pipeline should have a gradient of 1-2° , which is conducive to the discharge of condensate water in the pipeline.

If the system needs a lot of compressed air in a short time, you'd better use an air tank as a buffer. This helps the compressor to extend its life.

4. Cooling water volume of screw air compressor

No.	Model	Water flow volume(liters/min)	Remarks
1	75W	55	
2	100W	75	
3	120W	90	
4	150W	110	
5	175W	132	

Chapter 4 System flow of air compressor and function of parts

1. Brief introduction

The air compressor unit is a closed box structure, which includes air compressor, transmission system, inlet and exhaust system, cooling and lubricating system, control system and electrical system. All parts are mounted on high strength structural base.

2. Transmission system

The motor drives the air end of air compressor through belt or gear.

The cooling fan is driven by a separate fan motor.

3. Inlet and exhaust system

After the air is removed from the dust by the air filter, the air is compressed within the compression chamber of air end through the intake valve and mixed with the lubricating oil. The mixed air after the compression enters into the Oil/Air separator tank for the initial separation. The mixed air after the initial separation enters the precision Oil/Air separator for precision separation and enters the post cooler through the minimum pressure valve and then enters the gas pipeline through outlet valve.

4. Function of main parts

4.1 Air Filter

The air filter is a dry type heavy load paper filter. Usually, the dust on the surface should be removed every 1000 hours. The way to remove the dust is through the blow from the inside port.

4.2 Air intake valve

The working principle of piston type intake valve: the use of piston forward and backward action to do empty load control. When the star phase is changed to triangle phase, the controller opens the normally closed solenoid valve, the compressed air pushes the piston backward, opens the intake valve, and the compressor is in the state of full load. When the

rated pressure is reached, the controller will close the normally closed solenoid valve, the compressed air pushes the piston forward, closes the intake valve and the compressor is in the state of no load. Release valve release the pressure.

The working principle of butterfly intake valve: when the air compressor starts, the plate of intake valve is close to ensure that no load start. When load, if the system uses much less air, the pressure rise speed exceeds the reaction capacity of the valve adjustment, then the pressure switch will act to makes the solenoid valve to be turned off, the valve stem is back to the bottom of the cylinder under the action of the spring force, and the plate of the intake valve is in the whole close state, at the same time, the pressure in the air compressor system is discharged through the relief valve, and the air end is in no load status. When the system pressure drops to the set value, the controller lets the electromagnetic valve to get electricity and returns to the loading state.

4.3 Airend

Our company adopts the high-quality airend for double screw air compressor. The inlet port is located at the upper portion of the casing, the discharge port is located at the lower portion the casing, a pair of high precision positive rotor and negative rotor is parallel mounted in the casing.

4.4 Oil/Air separator tank

The Oil/Air Separator tank is an oil storage equipment of lubricate oil, and it is also the primary separation device for the Oil/Air mixture. The compressed air enters into the Oil/Air separator tank, the big oil droplet can be separated through impact, the cyclone separation and the flow velocity reduction, and so on.

4.5 Safety valve

When the pressure in the Oil/Air separator tank reach more than 10% higher than the rated pressure, the safety valve opens, which reduces the pressure to the set exhaust pressure and protects the whole system.

Notice! The safety valve has been adjusted before leaving the factory, please do not

adjust it at will.

4.6 High precision Oil/Air separator element

The high precision Oil/Air separator element is made of multi-layer micron grade glass fiber. Most of the oil is separated from the compressed air, and the oil content can be less than 3ppm after the compressed air passes through the Oil/Air separator element.

4.7 Minimum Pressure Valve

The minimum pressure valve is located at the outlet of Oil/Air separator element on the upper part of the Oil/Air separator tank, the opening pressure is about 0.45Mpa. When the system pressure reaches the pressure, the minimum pressure valve works. Its main function is to set up the circulation pressure of the system first, ensure the lubrication of the system; to protect the precision Oil/Air separator element not to be damaged by the big pressure difference; to reduce the flow velocity through the precision Oil/Air separator tank element and to improve the effect of Oil/Air separation.

5. Cooling and lubricating system

5.1 System flow

The lubricate oil enters into oil cooler from Oil/Air separator tank through system pressure, after cooled in the oil cooler, then goes into oil filter and then the impurities to be removed. And the lubricate oil routes will be divided into 2 directions: One route is sprayed into the compression chamber at the lower portion of the airend to cool the compressed air; the other route enters into to the other side of the airend to lubricate the bearings, and then enters the Oil/Air separator tank accompanied with the compressed air. Most of the oil will be separated here, the rest compressed air with oil enters the precision Oil/Air separator element, the separated oil is gathered at the bottom of the separator element and to be discharged into airend from the oil return pipe.

5.2 Function of main parts

5.2.1 Lubricate oil

Adopting the special lubricate oil of the compressor, the flash point is 257°C and the pour

point is -42°C . It can be operated normally at the extremely bad climate and temperature environment (-5°C -45°C).

5.2.2 Oil cooler

The oil cooler is made of aluminum. The cooling air is sucked by the cooling fan, and the lubricate oil is cooled by the oil cooler.

5.2.3 Oil Filter

Adopting precision filter, the filtration accuracy is less than $15\mu\text{m}$, which ensures the lubricate oil clean, and has good protection for bearings and rotors. If the pressure difference of oil filter with differential pressure indicator is too high, indicating that the oil filter is blocked, the oil filter element should be replaced in time.

5.2.4 Cooling Fan

The cooling fan is driven by a single fan motor, and the cold air is sucked from the outside. After cooling the lubricate oil and compressed air through the cooler, the hot air is discharged out.

5.3 Control system and electrical circuit

5.3.1 Motor start (lower voltage or Y start)

The air intake valve is completely closed and the discharge valve is fully opened. The lubricate oil needed in the compression chamber and bearing is ensured by the vacuum of the compression chamber and the pressure difference of the Oil/Air separator tank.

5.3.2 Star delta conversion (motor full voltage operation) and loading

After the control is converted to the full pressure operation, the discharge valve is completely closed and the air intake valve opens, so the pressure in the Oil/Air separator tank rises rapidly. When the pressure rises to 0.45 Mpa , the MPV (short for Minimum Pressure Valve) is fully open and the compressed air is discharged.

5.3.3 Heavy load / Empty load operation

When the discharged pressure reaches the rated pressure, the control system cuts off the power supply, the release valve opens, the air intake valve closes, and the air in the Oil/Air

separator tank is discharged into the atmosphere. At this time the air compressor runs under the condition of empty load, and the lubricate oil required is ensured by the vacuum of the compression chamber and the pressure difference of the Oil/Air separator tank.

5.3.4 Shut down

After pressing the OFF button, the release valve is opened, the air intake valve is closed, and the air in the Oil/Air separator tank is discharged into the atmosphere, the motor stops after a certain period of time.

5.3.5 Emergency shutdown

When the exhaust temperature exceeds the maximum exhaust temperature, or overload of the motor leads to the overflow device to work, the power supply will be cut off and the motor can be stopped. At the same time, the release valve is opened and the air intake valve is closed.

Notice! The emergency stop button is allowed only when an abnormal condition occurs during the operation of the machine.

5.3.6 Electrical circuit and cables

The compressor circuit has two systems: one is the computer controller (refer to the computer controller manual), the other is the boot disk.

Chapter 5 Operation and use

1. Safety operation regulations

In order to avoid body injury to the person and damage to the machine, the customer should make detailed safety procedures. The following points are for reference.

1.1 The operators should be rigorously trained in advance and carefully read and understand the instructions.

1.2 The installation, use and operation of compressor shall comply with the relevant laws and regulations of the country and the local.

1.3 It is strictly prohibited to change the structure and control method of the air compressor at will, unless there is a written permission from the manufacturer.

1.4 Abnormal conditions should be stopped immediately and power to be cut off.

1.5 Flammable, explosive, toxic and corrosive gases should not exist in the surrounding environment.

1.6 The air compressor must be shut down, unloaded and cut off the power supply before service or adjusting the compressor.

2. Inspection of the rotary direction of the compressor

After the compressor is connected to the power supply, pressing start button for a few seconds (the shorter the time is, the better it is), then press the red emergency button. At the same time, check the rotary direction of the compressor main shaft (there is rotary arrow logo on air end), compressor rotary direction must be consistent with the arrow sign. If the rotary direction is not correct, please replace any two cables of the 3 phase wires.

3.Start

The following steps should be followed when starting the air compressor:

3.1 Confirm that all preparations and inspections described in the installation section are completed.

3.2 Check whether the wiring is correct.

3.3 Check whether the pipe is leaked.

3.4 Check whether the oil level in the Oil/Air separator tank is between the upper oil level and the lower oil level.

3.5 If the compressor stops for a long time (more than two months), about 1 liter lubricate oil should be added from the air intake valve to prevent to be ruined due to loss of oil from the compressor when start. Please pay special attention not to let the external impurities to be fallen into the compressor airend so as not to damage the air compressor.

3.6 Press the compressor button.

4. Normal operation

See the running parameters during the run.

5. Shut down

Press the compressor stop button and the compressor will stop after about 10-30 seconds.

6. Attentions of the running

6.1 The compressor should be stopped immediately when there is abnormal sound or vibration in operation.

6.2 There is pressure in pipelines and pressure vessel during operations, it is not allowed to loosen the bolts and connections of the pipelines.

6.3 If it is found that the oil level of the oil level indicator cannot be seen and the discharged temperature rises gradually after the long operation, the compressor should be stopped immediately, and the oil level should be observed after ten minutes of shutdown. The lubricate oil will be supplemented when there is no pressure inside the system.

6.4 During operation, parameters such as pressure, temperature and oil level must be recorded for reference in future maintenance.

Chapter 6 Maintenance and Repairs

1. Brief introduction

Good maintenance and repairs are the guarantee of the normal operation of the air compressor, and it is also a prerequisite for reducing the wear of parts and prolonging the life of the compressor. Therefore, the maintenance and repairs of the compressor must be carried out seriously.

Notice! Do not dismantle nuts, end covers and other components when there is pressure in the compressor operation or system. Maintenance and repairs can only be carried out when shut down and the internal pressure is fully released.

2. Daily maintenance

Before the machine is started, check the oil level of the compressor lubricate oil, if the oil level is too low, then it needs to be refilled; check whether the joints are reliable, whether there is phenomenon of bolts, nuts loosening or damage and so on; open the drainage valve of the Oil/Air separator tank and put the condensate water to be fully discharged. Check whether the display values on the LCD panel are right or not after the compressor runs; Check whether the compressor has leakage or not, any internal pressure should be fully released before handling with them if leakage is found.

3. Belt adjustment (Belt driven air compressor)

3.1 The belt of the new air compressor must be inspected after 30 hours' running for the first operation. If it is too loose, it should be adjusted immediately and adjusted every 1500 hours later.

3.2 When changing the belts, all the belts should be replaced together, that a belt to be replaced is not allowed, otherwise the tension will be unbalanced.

3.3 Be careful not to splash the lubricate oil onto the belt and pulley when adjusting or replacing the belt.

3.4 The motor wheel and the aircend wheel must be at the same plane after adjustment,

otherwise the belt will wear easily and abnormal noise will occur.

4. Replacement and adjustment of parts

Be sure to familiarize yourself with all safety procedures mentioned before maintenance and replacement of the parts.

4.1 Maintenance of air filter

The air filter element must be cleaned when the compressor runs 1000 hours each time. Open the rear cover, take out of the air filter, clean the inside shell of the filter with wet cloth, using 2-3 bar compressed air to remove the dirt of filter from the inside of filter. Generally it is changed every 3000 hours, shortening the replacement period if the environment is poor.

4.2 Maintenance of oil filter

The oil filter element should be replaced if any situation occurs below.

The compressor was first operated for 500 hours.

Running every 4000 hours.

Each time when the lubricate oil is replaced.

The pressure in the pipelines should be fully released when the oil filter is replaced, remove the old oil filter element and washers with wrench, clean the seal surface, put a clean lubricate oil on the new washer, tighten the new oil filter element with hands, then turn the 1/2-3/4 circle, and finally start air compressor to check if there is any leakage.

4.3 Maintenance of Oil/Air separator element

When the pressure gauge on the Oil/Air separator tank shows 1 bar higher than that displayed on the liquid crystal display, the Oil/Air separator element needs to be replaced.

The pressure in Oil/Air separator tank and pipelines should be released.

Dismantle any pipes which are linked to the Oil/Air separator tank.

Dismantle any bolts of the cover of the Oil/Air separator tank.

Take down the cover of the Oil/Air separator tank.

Take out the Oil/Air separator element.

Clean the sealing surface between the top cover and the body of the Oil/Air separator tank,

and the impurities are not allowed to fall into the tank.

Carefully put the new Oil/Air separator element and the sealing gasket on it into the tank body, pay attention not to collide with the shell of the tank.

Re-install the cover and fasten the bolts.

Re-install the pipeline and put oil return pipe to the bottom of the Oil/Air separator element, otherwise it will affect the oil return and cause oil leakage accident.

5. Discharge condensate

The condensate in the air may be stored in the tank, especially in wet weather, when the exhaust temperature is lower than the pressure dew point or cooled after the shutdown, there will be more condensation water. Too much water in the oil will cause the emulsification of the lubricate oil, which will affect the safe operation of the compressor, such as the poor lubrication for the air end of the compressor, the poorer oil separation result, the bigger pressure difference of the Oil/Air separator element and the corrosion. Therefore, the discharged schedule for condensate should be carried out according to the humidity condition.

The discharged method of condensate water is performed when the machine is stopped and fully cooled and the condensate is fully precipitated. For example, the early first start on morning.

- Screw out the front screw plug of the ball valve.
- Slowly open the ball valve to drain until the oil flows out and close the ball valve.
- Screw up the front plug of the ball valve.

6. Replace the lubricate oil

Oil replacement must be carried out after the compressor is shut down and no internal pressure.

Oil discharge should be carried out according to the following steps.

- Start the air compressor to make the exhaust temperature at 75-85°C, the lubricate oil is fully preheated, and wait till the internal pressure is released after shutdown.
- Prepare the oil container and screw out the front screw plug of the ball valve.

-
- Slowly open the ball valve to discharge oil.
 - For the water cooling compressor, the oil drain plug at the bottom of the oil cooler should be screwed out, and the oil in the oil cooler will be fully discharged.
 - Close the ball valve and screw up the screw plug.
 - The discharged waste oil should be properly handled with.

7. Fill new oil according to the following steps

7.1 For large water cooling compressor, the fuel plug should be screwed out at the upper part of the oil cooler, and fill the oil cooler with oil.

7.2 Open the filling hole on the oil tank and the lubricating oil is added to the oil tank.

7.3 Start compressor after screwing up the screw plug for 3-5 minutes. Observe the oil level. The oil level should be between the lowest oil level and the highest oil level (the 1/2 height of the oil indicator). Any excess shall be discharged and deficiency shall be refill.

7.4 Fill in replacement records

Oil replacement should be changed every 3000 hours or so under normal circumstances.

8. Compressor oil supplement

In the running conditions, the oil level of the compressor should be kept between the lowest oil level and the highest oil level (1/2 oil indicator). The more oil will affect the separation effect, and the less oil will affect the lubrication and cooling performance of the compressor. If the oil level is lower than the lowest oil level, lubricate oil should be supplemented in time.

8.1 Stop compressor till the internal pressure is fully released, and then turn off the power switch.

8.2 Open the fuel hole on the oil tank and fill the right amount of lubricate oil to the oil tank.

9. Compressor lubricate oil

The genuine compressor oil must be used, and the oil should be changed strictly according to the requirements. The inferior compressor lubricate oil will cause the following consequences.

9.1 Carbon deposition or oil emulsification, blocking the oil route, and failure of the valves.

When it is serious, the whole system will be paralyzed and the airend will be burned down.

9.2 The poor oil separation effect, shortening the service life of the oil separation element and the oil filter.

9.3 Service life should be shortened for the moving parts of air end.

Therefore, the lubricate oil of the compressor should be used for the special screw air compressor lubricate oil. Add or replace lubricate oil of the same manufacturer and the same brand. Lubricate oil from different brands and different manufacturers cannot be mixed to use.

Screw compressor oil must meet the following requirements:

- High antioxidant stability.
- High temperature stability.
- The possibility of reducing the formation of sedimentary sludge.
- Reducing the formation tendency of bubbles, beneficial to separation.
- With high ignition point and flash point, non-flammable. The flash point should be higher than 200°C.
- The pour point must be less than the lowest operation environment by minus 5°C.
- Better air separation performance, beneficial for separation and reduction of the oil content in the air.
- Good corrosion resistance.
- Long service life.
- Must be special screw compressor lubricate oil.

When the air compressor leaves factory, the special lubricate oil is filled, the ISO viscosity class is 46.

Notice! Some illegal businessman on the market use ordinary lubricate oil as screw compressor oil, which may cause serious machine failure after use, Therefore, it is necessary to purchase carefully.

Chapter 7 Fault analysis and troubleshooting

1. Brief introduction

The contents in the fault analysis and troubleshooting sheet are based on the conditions of the experimental application and the extensive experiment of the manufacturer, which includes the failure and the general cause of the failure.

Here, it is important to emphasize the importance of collecting the operation data of the compressor systematically. According to these data, the operator can find the changes in the performance and check out the hidden trouble of the serious fault, for example, the vibration intensification may be caused by the over wear of the bearings.

Before repairing or replacing parts, a comprehensive and systematic analysis of the various types of failure may be made. In order to avoid unnecessary damage to the compressor, a careful visual inspection is necessary, and the following points should be kept in mind.:

1.1 Check whether the wire is loose.

1.2 Check whether there is any damage to the pipeline.

1.3 Check whether there is a component damage caused by overheating or short circuit.

Generally, the more obvious symptoms are color change or burning smell.

If the trouble cannot be eliminated according to the recommended check method, please consult the service department of our company.

2. Fault analysis and troubleshooting sheet

Failure	Possible reason	Troubleshooting
1. Unable to start	1. Fuse burn down 2. Protective relay action 3. Bad start button contact 4. The voltage is too low 5. Motor failure 6. Air end failure	1. Ask the electric personnel to repair and replace 2. Ask the electric personnel to repair and replace 3. Ask the electric personnel to repair and replace

		<p>4. Ask the electric personnel to repair and replace</p> <p>5. Ask the electric personnel to repair and replace</p> <p>6. Turned by hand, if unable to turn, please contact the service department.</p>
<p>2. High exhaust temperature (over 105°C shutdown)</p>	<p>1. High ambient temperature</p> <p>2. Failure of temperature control valve</p> <p>3. Lack of lubricate oil</p> <p>4. Oil cooler fins is too dirty</p> <p>5. Oil filter blockage</p> <p>6. Cooling fan failure</p> <p>7. Failure of temperature sensor</p>	<p>1. Improve the surrounding ventilation</p> <p>2. Check/replace the temperature control valve</p> <p>3. Check/adjust the oil level</p> <p>4. Clean cooler fins</p> <p>5. Replace oil filter</p> <p>6. Replace the cooling fan</p> <p>7. Check/replace temperature sensor</p>
<p>3. Low exhaust pressure</p>	<p>1. Air demand exceeds supply</p> <p>2. Air filter block</p> <p>3. The air intake valve cannot be fully opened</p> <p>4. Block of Oil/Air separator element</p>	<p>1. Check the leakage of the pipe</p> <p>2. Clean or replace air filter</p> <p>3. Check air intake valve</p> <p>4. Check the pressure gauge of the Oil/Air separator element and display pressure value of the LCD panel, and replace it if necessary.</p>
<p>4. Unable to unload, the system pressure still keeps working or continues to rise.</p>	<p>1. Malfunction of air intake valve</p> <p>2. Failure of pressure sensor</p> <p>3. Failure of release valve</p>	<p>1. Check air intake valve</p> <p>2. Repair, change if necessary</p> <p>3. Repair, change if necessary</p>
<p>5.</p>	<p>1. Pipe leak</p>	<p>1. Check pipelines</p>

Load/unload frequently	<ul style="list-style-type: none"> 2. Pressure difference is small 3. Air consumption is unstable 	<ul style="list-style-type: none"> 2. Reset 3. Increase the capacity of air receiver
6. Excessive oil content in the compressed air and excessive oil consumption	<ul style="list-style-type: none"> 1. High oil level 2. Block to oil return pipe filter or throttle 3. Breakage of Oil/Air separator element or gasket 4. Lubricate oil system leak 5. Too low discharged pressure 6. Too much lubricate oil foam 	<ul style="list-style-type: none"> 1. Check the oil level and release the oil to the normal position 2. Clean the return pipe filter screen and throttle hole, replace it if necessary. 3. Check the filter and gasket, if the damage then changes. 4. Check pipelines 5. Increase discharged pressure 6. Replace lubricate oil

Chapter 8 Storage requirements

Air compressor and their auxiliary equipment should be stored in dry and ventilated storeroom or in areas not covered with damp. Anti-rust and Anti mildew treatment should be made during the storage period.

When the compressor is not in use for a long time (more than two months), it must be checked and maintained regularly. When re-start, it should be operated according to the procedures described in this manual.

1. Safety attentions

1.1 Installation

The installation of compressors shall comply with the relevant local laws and regulations and strictly abide by the following provisions

The compressor should be hoisted by lifting equipment with load-bearing capacity larger than the weight of the equipment. The speed and acceleration of lifting should be limited to the permitted scope.

1.2 Try to install compressors in cool, clean, well-ventilated areas to ensure that the compressor suck clean air and moisture content is minimal.

1.3 The air sucked by the compressor is not allowed to contain flammable gases and corrosive gases, so as to avoid possible explosion or internal corrosion.

1.4 The discharged waste water of compressor and waste oil shall comply with the provisions of the local environmental protection department.

1.5 The cooling water quality of the water-cooled compressor should meet the following requirements.

1.5.1 The total hardness is expressed as CaCO_3 , which should be less than 100PPM (100 mg / L).

1.5.2 The PH value is between 6.0~8.0.

1.5.3 The suspended matter does not exceed 50PPM (50 mg / L).

1.5.4 Poor quality cooling water will reduce the cooling effect of the cooler, which will cause

the whole cooler to fail and not be used if more severe.

1.5.5 50HZ three phase AC power supply is adopted for this series of compressors, the voltage is determined by user's orders, 380V, 6KV, 10KV, etc. can be chosen. The control power supply uses AC power 380V/50HZ/3PH, and requires reliable grounding. The relevant high voltage electrical operation regulations should be followed for high voltage equipment.

1.5.6 Before starting the compressor, read this manual carefully "operation and use", the rotary directions of the compressor and cooling fan must be run in the prescribed directions (the rotary direction of the cooling fan should be referred to the sign on the motor), otherwise the compressor may cause oil shortage or temperature rise.

1.5.7 When the compressor is in remote control mode, the compressor may be started at any time, some reminding signs should be hanged.

2. Maintenance and repairs

The maintenance and repair of the compressor must be carried out under the guidance of qualified personnel.

2.1 The right tools must be used.

2.2 The original parts of our company must be used, otherwise the company will not bear any liability for the compressor failure.

2.3 It is necessary to use the proper special screw compressor oil, otherwise our company will not bear any liability because of the compressor failure caused by the oil quality failing to meet the requirements.

2.4 Its discharged temperature may reach 100°C when the compressor runs, and some parts become very hot. Please do not touch these parts with hands so as not to get scalded.

2.5 The main power source must be cut off, and the connection with the external air route should be shut off too when it is necessary to repair the compressor, so as to ensure that the maintenance can be carried out without pressure and high temperature of the whole system.

To user

Dear user

First of all, we would like to thank you for purchasing the screw air compressor of our company.

In order to ensure the compressor can run safely and reliably, you must read this manual carefully before using this air compressor.

The provisions stipulated in this manual are applicable to the compressor of our company. The accompanied manuals (such as motor and cooler) are also applicable to the according products.

Users should know the local laws and regulations on compressor installation and use, and abide by them.

When the terms specified in this manual are not in accordance with the relevant local laws and regulations (especially in terms of safety), the more secure clause prevails.

The operator has the responsibility to ensure that the compressor is running under safe conditions. If it is considered that the compressor is unsafe, the repair should be carried out in time.

Please keep this manual properly so that you may read it at any time.