



亿宸集团
EACHAN GROUP



SKID STEER LOADER



SKID STEER LOADER-V1000

COMPLETE MODELS AND SUPPORT CUSTOMIZATION

PRODUCT DETAILS

FLEXIBLE, FAST AND ALWAYS THERE FOR YOU
Rapid assistance, tailored advice and reliable supply of original parts - that is what we mean by a premium service.

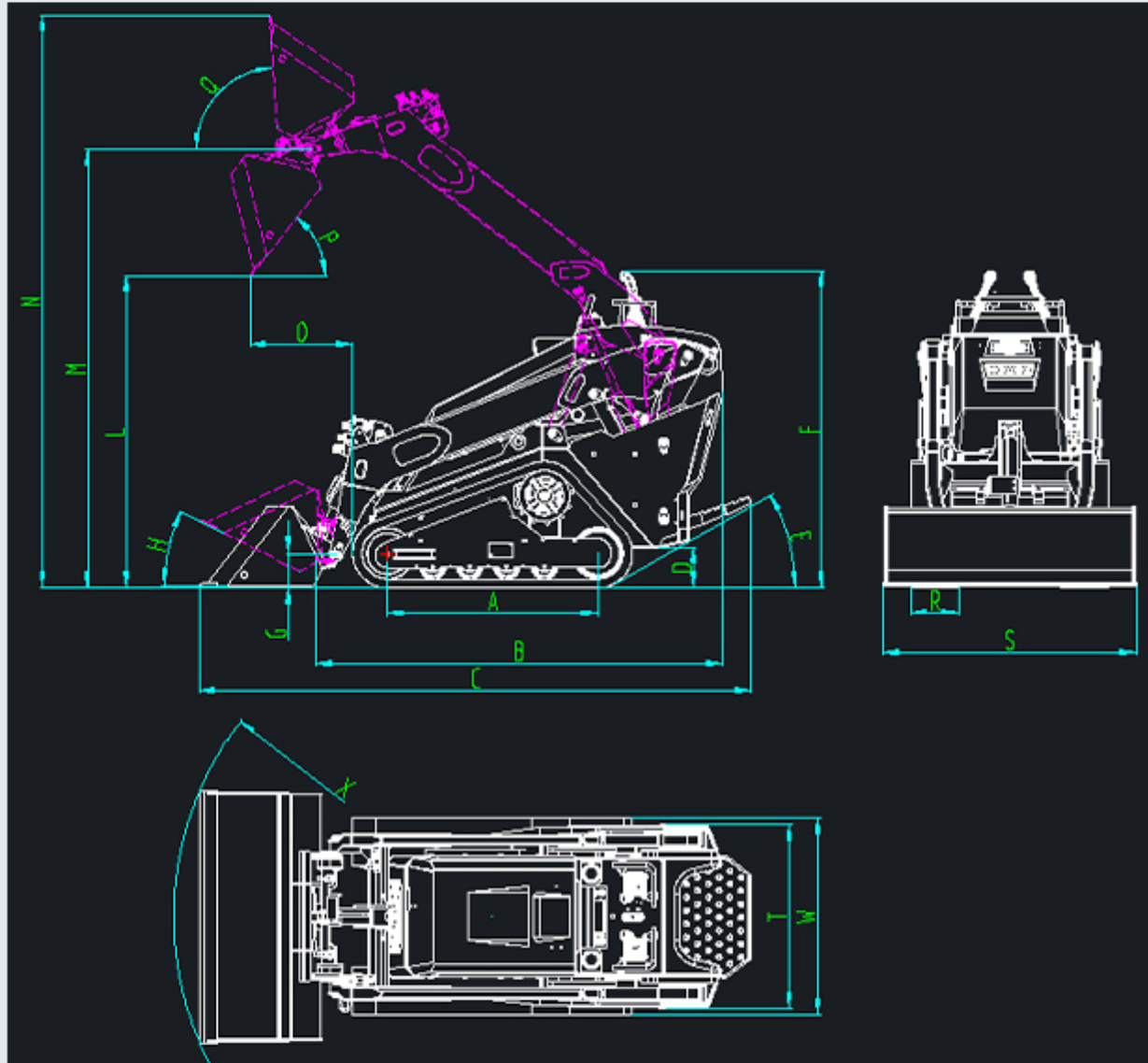

Complete vehicle equipment quality	1317Kg	The height from the bucket pin to the ground(G)	169mm		
Overall dimensions of the complete vehicle	2691*1250*1548mm	Bucket lifting angle(H)	27mm		
Maximum load	650kg	Dumping height(L)	1522mm		
Rated load	500kg	Maximum height of the bucket pin above the ground(M)	2140mm		
Bucket capacity	0.19m ³	Maximum height of the bucket above the ground(N)	2794mm		
Walk speed	0-4.5km/h	Bucket tilt angle(Q)	86°		
Rated pressure	19.5mpa	Unloading distance(O)	498mm		
Wheelbase(A)	1026mm	Bucket dump angle(P)	52°		
Minimum vehicle length (with pedals retracted and bucket removed)(B)	1981mm	Track width(R)	230mm		
Maximum vehicle length(C)	2691mm	Bucket width(S)	1250mm		
Ground clearance(D)	200mm	Frame width(T)	900mm		
Departure angle(E)	29°	Vehicle width(W)	960mm		
Ride height(F)	1548mm	Turning radius(X)	1556mm		
Brand	YANMAR	KUBOTA	Brand	YANMAR	KUBOTA
Model	3TNV80F-SDWB	D1105	Fuel tank	40L	40L
Type	Diesel, three cylinder, water-cooled		Oil tank	3.4L	3-5
output power	17.8kw/3000rpm	14kw/2200rpm	Hydraulic oil tank	30L	30L
Maximum torque	60~64N · M		Walking pump pressure	20mpa	20mpa
displacement	1267cc	1226cc	Working pump pressure	19.5mpa	19.5mpa
Fuel consumption	282g/kw · h	257g/kw · h	Working pump flow rate	48L/min	48L/min

EXTERIOR DESIGN

Unique Appearance Design Adaptable To Various Working Conditions

FLEXIBLE, FAST AND ALWAYS THERE FOR YOU
Rapid assistance, tailored advice and reliable supply of original parts - that is what we mean by a premium service.



[High power engine]

Danfoss motors HANSA closed plunger pump from Italy
The standard configuration of EPA engines that meet emission standards is a high-power engine with the characteristics of low fuel consumption and high efficiency



[Undercarriage]

The guide wheel has dual tracks, which can lock the tracks and prevent them from falling off easily. The front guide wheel is designed with spring tension, which provides better resistance to walking impact. The number of support wheels is higher than that of similar products.

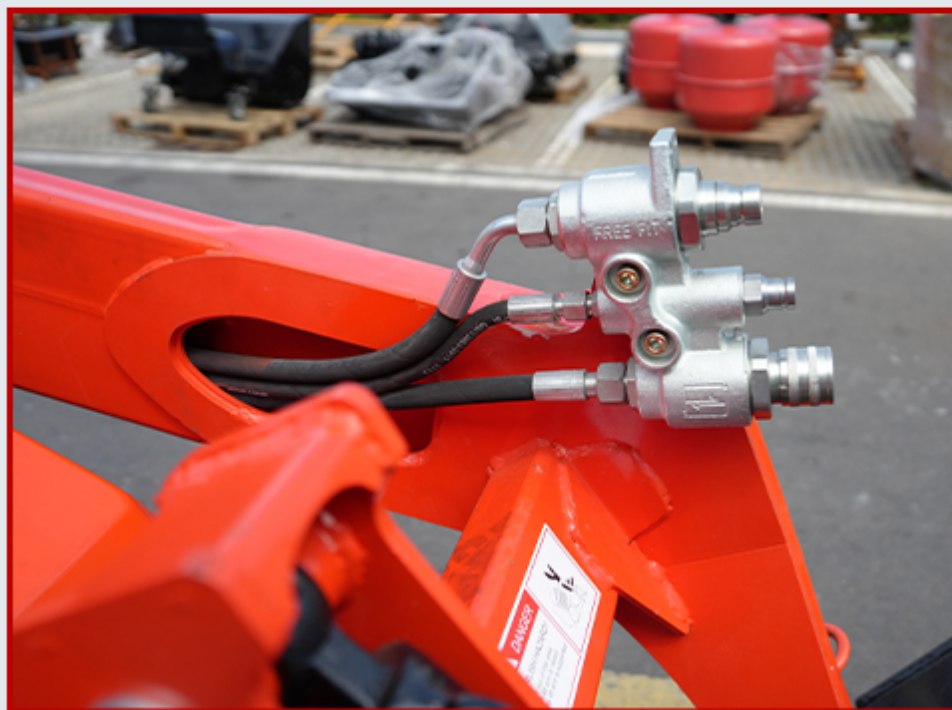

[Quickly replace the plug]

International standard with HANSA closed-loop hydraulic system, quick plug replacement, perfect for accessories necessary for high and low flow rates



[Dual pilot operating handle]

Lonking Dual Pilot Operating Handle
Can control walking with one hand, and can operate the boom and bucket during the walking process



[LCD touch screen]

Standard LCD touch screen, cigarette lighter, uSb interface, and accessory electronic control button operation

SAFETY AND PROTECTION

ENSURE OPERATIONAL SAFETY



[Hydraulic oil circulation radiator]

Equipped with a temperature sensor, arranged separately from the engine to solve the problem of high temperature heat dissipation. The back is equipped with an automatic fan and an automatic rotating system for faster heat dissipation

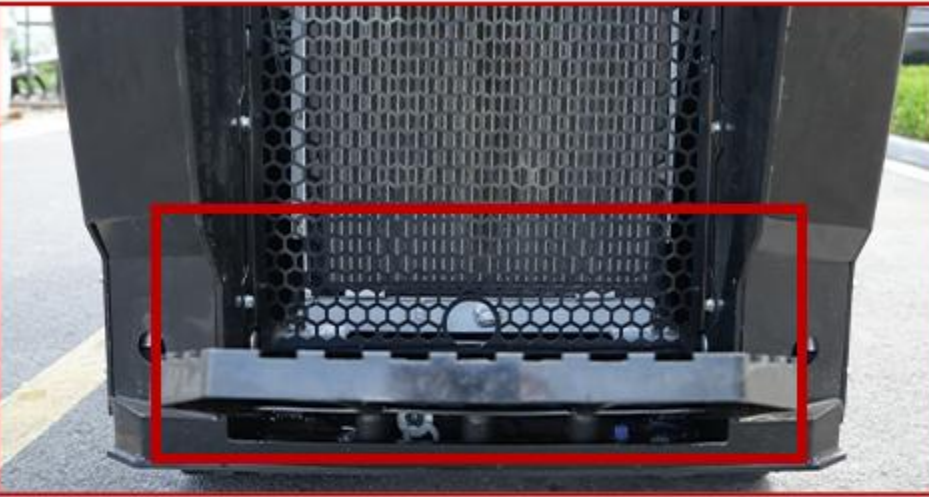

[Departure safety lock]

People have movement on the pedals, but there is no movement when they get off, which plays a safety role for people to leave the vehicle
Standard load capacity of 500 kilograms
The maximum weight for a person above is 650 kilograms

[Automatic bucket leveling system]

Separate from engine - automatic bucket leveling system



[Vertical lifting function of the upper arm]

Maximum height for machine lifting 2794 millimeters



[Built in hydraulic hose]

Hydraulic hoses are installed inside the lifting arm of the machine, providing anti debris protection and preventing them from entering the operator's view

CAN BE PAIRED WITH VARIOUS ASSISTIVE DEVICES

Support customized machines with quick replacement of accessories
Suitable for various scenarios, excavation/trenching/drilling/crushing/grabbing/weeding



4 in 1 bucket

Trench filler

High dump bucket

Sweeper with bucket

Ice grinder



Angle blade

Concrete mixer

Grapple

Fork

Miling palaner



Pitchfork

Trencher

Digger

Stone bucket

Tiller



Stump grinder

Standard bucket

Crane

Ripper

Hydraulic breaker



Leveler

Auger

Lawn aerator

Snow blower

Sweeper

FLEXIBLE, FAST AND ALWAYS THERE FOR YOU
Rapid assistance, tailored advice and reliable supply of original parts - that is what we mean by a premium service.

COMMITTED TO PROVIDING YOU WITH HIGH-QUALITY SERVICE



Shandong Eachan Machinery Group Co., LTD.
<https://www.eachanexcavator.com/>
Eachan Industrial Park, Kaixuan Road, Hightech Zone, Jining City, Shandong Province



FLEXIBLE, FAST AND ALWAYS THERE FOR YOU
Rapid assistance, tailored advice and reliable supply of original parts - that is what we mean by a premium service.