

Amy Yang | EVERWINNER
WhatsApp 联系人



TIRE REPAIRS - AMY YANG
WhatsApp + 86 13336657152
WeChat: +86 13336657152
EMAIL : everwina@qq.com

Contact : Augusta Amy Yang

Address: Building #13, No.348 MeiDiShi Road, Wuxiang Industrial Area, Yinzhou District, Ningbo, China (zip code:315111)
TEL: 0086-13336657152 WhatsApp / Wechat
Email: amy@cneverwin.com everwina@qq.com





COMPANY PROFILE

Ningbo Jutong Auto Parts Co.,Ltd(Name has been known Ningbo Yinzhou Dongfang Auto Parts Factory) located in Ningbo which is a beautiful seaside city in East China with convenient transportation access.

Our company is specialized in manufacturing various of tire valves, tire repair tools and rubber products etc. We established in 1996, currently employs more than 100 people and has a plant area of 2,000 square meters. We obtained the ISO9001-2000 international quality control system certificate and also the ISO:TS16949 certificate in 2005.

Our products now have been exported to Western Europe, Australia, Central and South America, Southeast Asia and the Middle East countries etc, win a good reputation from both domestic and foreign markets. As the market continues to evolve, we are also constantly improving and innovating with the purpose of providing high quality products with competitive prices to our customers.

Integrity and quality guarantee is our service purpose ! Sincerely welcome your visiting !

宁波炬通汽配有限公司（原宁波市鄞州五乡东方汽配厂），座落在秀丽的东海之滨宁波，水陆交通极为便捷。

我司是一家专业生产气门嘴、修补工具及橡胶的企业，于1996年建厂，目前员工100余人，厂房面积2000平方米，于2005年通过ISO9001:2000质量管理体系认证以及ISO:TS16949体系认证。产品远销西欧，澳大利亚，中南美，东南亚以及中东国家，产品质量及包装收到国内外客户一致好评。随着市场的不断更新换代，我们也在不断的改进，创新，开发新产品，竭力为客户提供质优价廉的产品。我司的诚信、实力和产品质量获得业界的认可。欢迎各界朋友莅临参观、指导和业务洽谈。



TIRE VALVE ACCESSORIES
气门嘴附件

01-40

VALVE EXTENSIONS
充气延长嘴

41-44

TIRE REPAIR STRIP
胶条

45-46

AIR CHUCK
充气夹头

47-50

WORK SHOP TOOLS
补胎工具

51-60

TIRE GAUGES
胎压表

61-64

目 录

TPMS Valves
胎压监测 / 传感器气门嘴

TIRE VALVE ACCESSORIES
气门嘴附件



MS525AL-Round Base
(圆底)

MS525AL-Flat Base
(平底)



JT NO.	ETRTO NO. (REF.NO.)	EFF.LENGTH (mm)	RIM HOLE (mm/in.)	PARTS			
				GROMMET	WASHER	NUT	CAP
MS525AL-Round Base	-	Φ18x48	Φ11.5/.453"	RG54	RW15	HN9	ET
MS525AL-Flat Base	-	Φ18x42	Φ11.5/.453"	RG54	RW15	HN9	ET

Tire Pressure Monitoring System



传感器气门嘴



胎压监测系统



TPMS Valves 胎压监测 / 传感器气门嘴



TPMS-01



TPMS-02



TPMS-03



TPMS-04B



TPMS-05



TPMS-06



TPMS-07



TPMS-08



TPMS-09



TPMS-10



TPMS-11



TPMS-12



TPMS-13



TPMS-14



TPMS-15



TPMS-16



TPMS-17

TPMS Valves

胎压监测 / 传感器气门嘴



Bicycle valve

自行车真空胎法式气门嘴



JT NO.	L(mm)
FTG-01	34/40/42/48/60/80

JT NO.	L(mm)
FTG-02	34/40/42/48/60/80

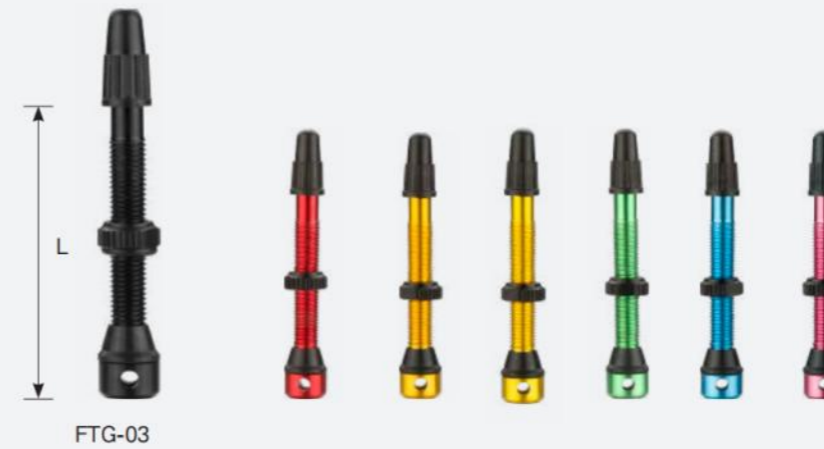

JT NO.	L(mm)
FTG-03	34/40/42/48/60/80

Bicycle valve 自行车真空胎法式气门嘴



JT NO.	L(mm)
FTG-04	34/40/42/48/60/80
FTG-05	34/40/42/48/60/80
FTG-06	34/40/42/48/60/80
FTG-07	34/40/42/48/60/80



Snap-in Tubeless Rubber Valves 卡扣式无内胎气门嘴

Cold, Heat and Ozone Resistant



TR NO.	ETRTO NO. (REF.NO.)	RIM HOLE	EFF. LENGTH (mm)	CORE	CAP	A	B	C
TR412	V2.03.6	11.5(.453" dia)	22	9002#	VC8	33	22	15
TR413	V2.03.1	11.5(.453" dia)	30			42.5	32	15
TR414	V2.03.2	11.5(.453" dia)	38			48.5	38	15
TR414L	V2.03.8	11.5(.453" dia)	45			56.5	46	15
TR418	V2.03.4	11.5(.453" dia)	49			61.5	51	15
TR423		11.5(.453" dia)	62			74	63.5	15
TR415	V2.03.3	16(.625" dia)	30			42.5	32	19.2
TR425		16(.625" dia)	49			61.5	51	19.2
TR438	V2.03 5	8.8(.346" dia)	32			40.5	31	11

Snap-in Tubeless Rubber Valves

卡扣式无内胎气门嘴
Cold, Heat and Ozone Resistant



TR413C-Y



TR413AC-G



TR413C-P



TR413C-R



TR413C-B



TR413C-G



TR413AC-B



TR413AC-Y



TR413AC-P



TR413AC-R



TR413C



TR414C



TR413AC



TR414AC



TIRE VALVE ACCESSORIES
气门嘴附件

High Pressure Snap-in Tubeless Rubber Valves

耐高压真空气门嘴
Cold, Heat and Ozone Resistant



TR600HP



TR602HP



TR801HP



TR802HP

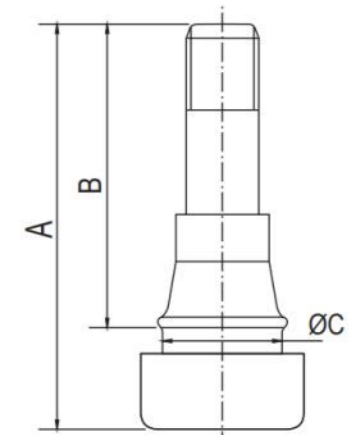

TR NO.	A	B	C	Rim Size
TR600HP	42.8	31	12.4	Φ11.3
TR602HP	61.3	50	12.4	
TR801HP	49	33.5	17	Φ15.7
TR802HP	66	50.5	17	

Motorcycle aluminum alloy valve 摩托车铝合金改装气门嘴



TR416SS



TV435



V5

JT NO.	ETRTO NO.	RET.LENGTH	RIM HOLE
TV25AL	V2.07.1	Φ15x25/84°	8.3mm/11.3mm
TR416SS	-	Φ14x38	Φ11.5/.453"
TV435	-	Φ17.5x36	Φ11.5/.453"
V5	TR48E	Φ14x48	Φ11.5/.453"

Tubeless Valves For Motorcycles And Scooters

摩托车真空气门嘴



JT NO.	REF.LENGTH (mm)	RIM HOLE (mm/in.)	PARTS			
			GROMMET	WASHER	NUT	CAP
VAMD161	Φ16x34.5	Φ11.5/.453"	HG2	RW12	NH2	GT
JS-430	Φ14x37	Φ11.5/.453"	RG59	RW12	HN2	CT
TR-430A	Φ14x33	Φ11.5/.453"	RG59	RW12	HN2	CT
PVR-30	Φ15x63x90°	Φ11.5/.453"	HRG2/HG2	-	NH2	VC8
PVR-70	20x32x90°	Φ11.5/.453"	-	-	-	VC8
PVR-32	Φ16x54x90°	Φ11.5/.453"	-	-	SNM5	VC8

Tubeless Metal Clamp-in Valves

摩托车真空气门嘴



TR416SSS

TR416SS

TR NO.	ETRTO NO. (REF.NO.)	EFF.LENGTH (mm)	RIM HOLE (mm/in.)	PARTS			
				GROMMET	WASHER	NUT	CAP
TR416SS	-	Φ14x38	Φ11.5/.453"	V801	RW8	RW8	FT
TR416SSS	-	Φ14x39	Φ8.3/.327"	RG11	RW6	RW8	FT

Tubeless Metal Clamp-in Valves

轿车真空气门嘴



MS525S

MS525L

MS525AL

TR417



VS-8-45°

VS-8-90°

PVR153

TR NO.	ETRTO NO. (REF.NO.)	EFF.LENGTH (mm)	RIM HOLE (mm/In.)	PARTS			
				GROMMET	WASHER	NUT	CAP
MS525S	-	Φ17.5x41.5	Φ11.5/.453"	RG9,RG54	RW15	HN6	FT
MS525L	-	Φ17.5x41.5	Φ11.5/.453"	RG9,RG54	RW15	HN7	FT
MS525AL	-	Φ17.5x42	Φ11.5/.453"	RG9,RG54	RW15	HN9	FT
VS-8-45°	WH303 PVR75A	Φ16x53-45°	Φ11.5/.453"	HRG1,HG2	RW12	HN2x2	ET/BT
VS-8-90°	-	Φ16x63-90°	Φ11.5/.453"	HRG1,HG2	RW12	HN2x2	ET/BT
PVR153	-	Φ17xL-90°	Φ11.5/.453"	HRG39,HG2	RW1-2	WVC5	ET/BT
TR417	-	-	Φ11.5/.453"	RG54	-	HN4	VC-8

Tubeless Metal Clamp-in Valves

轿车真空气门嘴



TR5991B

TR416

TR416L

TR416S

V-8



V-3

V-4

V-5

VS-6

VS-8

TR-435

TR NO.	ETRTO NO. (REF.NO.)	EFF.LENGTH (mm)	RIM HOLE (mm/In.)	PARTS			
				GROMMET	WASHER	NUT	CAP
TR5991B	WH402	Φ19x34	Φ11.5/.453" Φ16/.625"	RG39 RG54	RW8	HN4	AT
TR416	-	Φ18.5x40	Φ16/.625"	RG39	RW13	HN4	AT
TR416B	-	Φ17x38	Φ11.5/.453" Φ16/.625"	RG39 RG54	RW8	HN4	AT
TR416L	-	Φ16.7/59	Φ11.5/.453"	RG59	RW8	HN4	AT
V-3	TR33E.WH23A	Φ14x33	Φ11.5/.453"	HRG2x2	RW5	HN2x2	ET
V-4	TR43E.WH206	Φ14x43	Φ11.5/.453"	HRG2x2	RW5	HN2x2	ET
V-5	TR48E	Φ14x48	Φ11.5/.453"	HRG2x2	RW5	HN2x2	ET
VS-6	TR53E.WH204	Φ14x53	Φ11.5/.453"	HRG2x2	RW5	HN2x2	ET
TR416S	-	Φ17x40	Φ11.5/.453"	RG54	RW8	HN4	AT
V-7	TR63E	Φ14x63	Φ11.5/.453"	HRG2x2	RW5	HN2x2	ET
V-8	TR26A	Φ16x34	Φ11.5/.453"	HRG1,HG2	RW12	HN2x2	ET
VS-8	TR26G, PVR43A	Φ16x38	Φ11.5/.453"	HRG1,HG2	RW12	HN2x2	ET
VS-9	JS43E	Φ16x43	Φ11.5/.453"	HRG1,HG2	RW12	HN2x2	ET
TR-435	-	Φ19x34	Φ11.5/.453"	RG54	RW8	HN4	ET

Tubeless Metal Clamp-in Valves For Truck And Bus

大巴车 / 轻卡真空气门嘴



FOR $\Phi 16$ (.625" dia.) RIM HOLES

TR NO.	ETRTO NO.	EFF.LENGTH (mm)	PARTS								
			CORE	GROMMET	WASHER	NUT	CAP				
TR500	V3.21.3	$\Phi 19 \times 55$	9002#	RG15	RW8	HN13	DT				
TR501	V3.21.2	$\Phi 19 \times 42$									
TR570	V3.21.4	$\Phi 19 \times 84$									
TR571	V3.21.5	$\Phi 19 \times 90$									
TR572	V3.21.6	$\Phi 19 \times 100$									
TR573	V3.21.7	$\Phi 19 \times 115$									
TR574	V3.21.8	$\Phi 19 \times 131$									
TR575	V3.21.1	$\Phi 19 \times 33$									
TR570C	V3.21.9	$\Phi 19 \times 84 / 90^\circ \text{ or } 27^\circ$									
TR571C	V3.21.10	$\Phi 19 \times 90 / 90^\circ \text{ or } 27^\circ$									
TR572C	V3.21.11	$\Phi 19 \times 100 / 90^\circ \text{ or } 27^\circ$									
TR573C	V3.21.12	$\Phi 19 \times 115 / 90^\circ \text{ or } 27^\circ$									
TR574C		$\Phi 19 \times 131 / 90^\circ \text{ or } 27^\circ$									
TR500-35°	VS-1223R	$\Phi 19 \times 55 / 35^\circ$									
TR570P		$\Phi 12 \times 18$						RG7	RG11	HN1	

European Style O-Ring Seal Clamp-in Brass Valves

大巴车 / 轻卡真空气门嘴



TR NO.	ETRTO NO.	PARTS			
		CORE	GROMMET	NUT	CAP
V3.20.1	Φ16x41	9002#	V9.11.5 (RG60)	V9.07.2	DT
V3.20.2	Φ16x95/17.50				
V3.20.3	Φ16x82				
V3.20.4	Φ16x90/27°				
V3.20.5	Φ16x70/27°				
V3.20.6	Φ16x115/27°				
V3.20.7	Φ16x80/27°				
V3.20.8	Φ16x119/12°				
V3.20.9	Φ16x102/12°				
V3.20.10	Φ16x80/28°				
V3.20.11	Φ16x100/27°/42°				
V3.20.12	Φ16x100/27°				
58MS	Φ16x58/45°				

Aluminum bus Valve

铝合金大巴气嘴



TR NO.	ETRTO NO. (REF.NO.)	EFF.LENGTH (mm)	A(mm)	B(mm)	α	GROMMET	NUT
60MS-27	-	Φ16x5x60	40.5	19.5	27°	HRG70	HN22
70MS-7	-	Φ16x5x70	40.5	29.5	7°	HRG70	HN22

valve for air bag oil drum

气囊油桶专用气门嘴

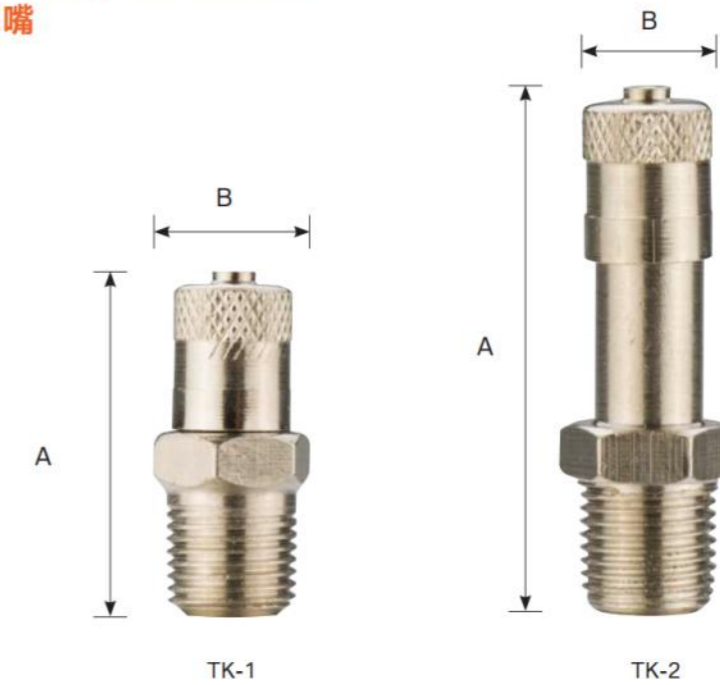

TR NO.	REF.LENGTH(mm)	A(mm)	B(mm)	BASE THREAD
TK-1	-	23	11	1/8NPT, 1/8BSPT
TK-2	-	33	11	1/8NPT, 1/8BSPT

Tubeless Nickel Plated O-Ring Seal Clamp-in Valves
摩托车真空气门嘴



RIM HOLE .382" - .394" (9.7-10MM)

TR NO.	PARTS				A	B	α°
	CORE	GROMMET	NUT	CAP			
TR542					32	-	-
TR543					59	-	-
TR544					73	-	-
TR545					98	-	-
TR546					108	-	-
TR543C					24	35	45
TR543D					25	35	60
TR543E					25	35	75
TR544D					25	49	60
TR544E	9002#	RG60	HN21	VC2 or VC3	25	49	75
TR545B					25	55.8	26
TR545-36					25	66	36
TR545D					25	66	60
TR545E					25	66	75
TR546B					25	85	26
TR546-36					25	85	36
TR546D					25	85	60
TR546E					25	85	75
TR547D					25	96	60

TR550 Series

NICKEL PLATED BRASS VALVES WITH GROMMET

Application: For aluminum wheels with 9.7mm/10mm(0.382"/0.394") valve hole and rim thickness of 5.5mm-8.4mm(0.218"-0.330") at valve hole, recommended torque at installation:80-125in-lbs(10-15N.m)

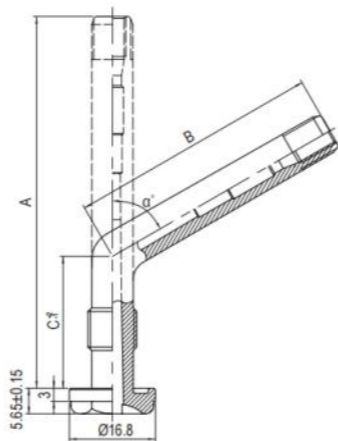

TR No.	A	B	C	α°	Rim Size	Cap	Valve Core	Hex Nut	Grommet
TR552	32	-	-	-	Ø9.7-10	DT	9002#	HN22	HRG70
TR553	58.5	-	-	-					
TR553C	58.5	35	23.6	45					
TR553D	58.5	35	25	60					
TR553E	58.5	35	25	75					
TR554	72.5	-	-	-					
TR554C	72.5	49	25	45					
TR554D	72.5	49	25	60					
TR555	89	-	-	-					
TR555D	89	66	25	60					
TR555E	89	66	25	75					
TR556	108.5	-	-	-					
TR556-36	108.5	85	25	36					
TR556D	108.5	85	25	60					
TR556E	108.5	85	25	75					
TR556G	108.5	85	25	105					
TR557	119.5	-	-	-					
TR557D	119.5	96	25	60					

Tubeless Metal Clamp-in Valves For Truck And Bus

大巴车 / 轻卡真空气门嘴

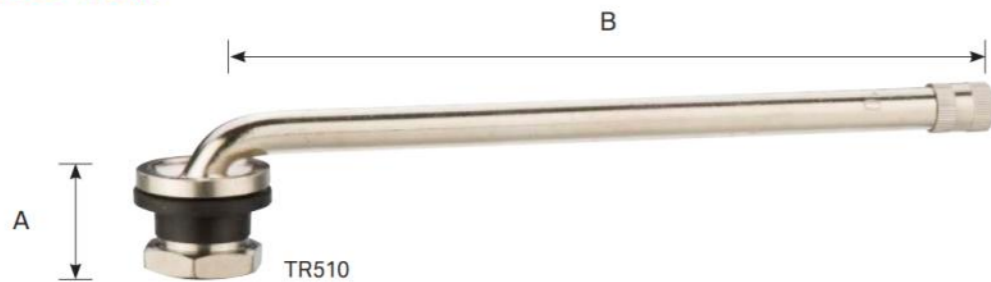

FOR $\Phi 16(.625"$ dia.) RIM HOLES

TR NO.	A	B	PARTS			
			CORE	GROMMET	NUT	CAP
TR509	26	120.5	9002#	RG46	HN17	DT
TR510	26	140				
TR511	26	108				

Flushmount Valves

隐藏式气门嘴

Flushmount Valves
This valve is designed for Flush Mount
 $\Phi 16(1.625"$
or $\Phi 11.5(.453"$) Rim Holes



V007 Set
(4pcs stems+2pcs caps+1pc adaptor)



V007S Set
(4pcs stems+2pcs caps+1pc adaptor)

V007-Adaptor

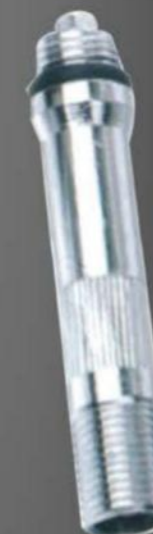

V007S-Adaptor



V007-Stem



V007S-Stem



V007-Cap



V007S-Cap

Air-Liquid Valves For Agricultural Tractors

工程车 / 农用车专用气门嘴



TR NO. (JT NO.)	ETRTO NO.	EFF.LENGTH (mm)	CORE HOUSING		PARTS			
			CORE	O.RING	CORE	GROMMET	NUT	CAP
TR CH3	V4.02.1	Φ11x36	9002#	HRG33(V9.11.6)	-	-	-	DT
TR CH1	-	Φ11x36		-	-	-	-	
TR 618A	V5.01.1	Φ22.5x30/510	TR CH3	-	RW11	RG7	HN1	
TR 618	-	Φ22.5x56		-	-	-	-	



JT NO.	ETRTO NO.	A	B	α°	CORE	O.RING	GROMMET	GROMMET	NUT	CAP
TR 621A	V5.02.1	42.5	55	65	TR CH3	RG7	RW32	RW31	HN3	DT
TR 622A	V5.02.2	47.5	94	90						
TR 623A	V5.02.3	42.5	36	65						

European Style Clamp-in Valves

欧式压紧式气门嘴

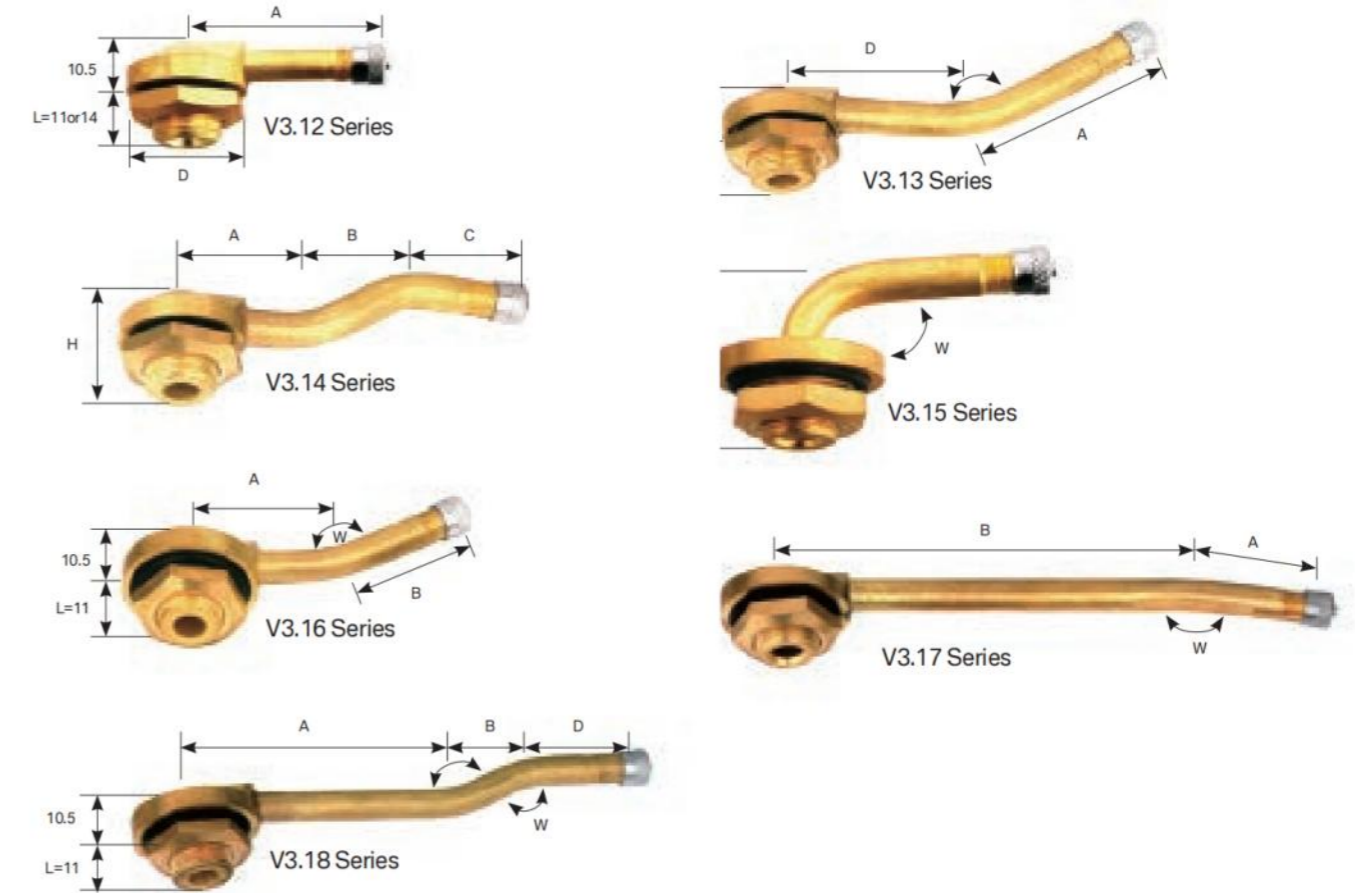

FOR Φ15.7(0.625") RIM HOLES

ETRTO NO.	PARTS				A	B	C	D	E	W°	H
	CORE	GROMMET	NUT	CAP							
V3.12.1	9002#	9.11.4	V9.13.1	FT	40	-	-	-	-	-	-
V3.12.2					95	-	-	-	-	-	-
V3.13.1					42.5	-	-	46.5	-	153	-
V3.13.2					79	-	-	30	-	126	-
V3.14.1					25	21.5	24.5	-	-	-	21
V3.14.2					45	21.5	24.5	-	-	-	21
V3.14.3					37	21.5	24.5	-	-	-	21
V3.15.1					14	22.5	-	-	-	110	-
V3.15.2					11	15.5	-	-	-	95	-
V3.16.1					36	29	-	-	-	150	-
V3.17.1					99	31.5	-	-	-	172	-
V3.17.2					116	31.5	-	-	-	172	-
V3.18.1					64	24.5	-	14.5	-	146	-
V3.18.2					81	24.5	-	14.5	-	146	-
V3.18.4					51	37.5	-	19.5	-	138	-
V3.18.5	68	37.5	-	19.5	-	138	-				

Large Bore Tubeless Valves

工程车 / 农用车专用气门嘴



JT NO.	D	L	WASHER	NUT	CAP
SP4	18	34	RW18	HN2.HN13	VC8
SP5	23	42.5	RW23	HN4.HN19	DT
SP6	31	38	RW32	HN13.HN17	DT
SP7	31	28	RW31	HN4x2	DT

Large Bore Swivel Type Valves

工程车 / 农用车专用气门嘴



TR NO.	HORIZ.LENGTH		O-RING	NUTS	CORE	CAP
TRJ4000-2.50	2 1/2"	64MM	V9-11-3	HN1	7002#	VC6 OR VC7
TRJ4000-4	4"	102MM				
TRJ4000-4.50	4 1/2"	114MM				
TRJ4000-6	6"	152MM				
TRJ4000-7.50	7 1/2"	191MM				
TRJ4000-8	8"	203MM				
TRJ4000-8.50	8 1/2"	216MM				
TRJ4000-9	9"	229MM				
TRJ4000-10	10"	254MM				
TRJ4000-20	20"	508MM				
TRJ4000-24	24"	610MM				
TRJ4000-25.50	25 1/2"	648MM				
TRJ4000-28	28"	711MM				
TRJ4000-29.50	29 1/2"	749MM				

Large Bore Swivel Type Valves

工程车 / 农用车专用气门嘴



TR NO.	STEM NO.	ETRTO NO.	A	B	α°
TRJ650-03	TRJ650-02	V5.04.1	27	79	80
TRJ651-03	TRJ651-02	V5.04.2	32	119	90
TRJ652-03	TRJ652-02	-	27	140	86
TRJ653-03	TRJ653-02	-	27	64	80
TRJ654-03	TRJ654-02	-	27	79	60
TRJ655-03	TRJ655-02	-	24	79	74
TRJ656-03	TRJ656-02	-	67	94	90
TRJ657-03	TRJ657-02	-	27	102	80
TRJ658-03	TRJ658-02	-	27	140	80
TRJ659-03	TRJ659-02	-	48	89	90
TRJ660-03	TRJ660-02	-	48	222	90
TRJ669-03	TRJ669-02	-	27	64	90
TR670-03	TR670-02	-	41	-	-

ScrJT-On Universal Valves 旋紧式气门嘴

JT NO.	A	B	c	α°	β°
V3.02.1	25.5	41.5	-	120	-
V3.02.2	22.5	43	-	120	-
V3.02.3	33	44.5	-	95	-
V3.02.4	39.5	44.5	-	110	-
V3.02.5	20.5	47.5	-	90	-
V3.02.6	23.5	60.5	-	110	-
V3.02.7	22.5	71.5	-	100	-
V3.02.8	20.5	89.5	-	94	-
V3.02.9	20.5	99.5	-	94	-
V3.02.10	20.5	115	-	94	-
V3.02.11	20	126	-	94	-
V3.02.12	20.5	132	-	94	-
V3.02.13	20.5	133.5	-	90	-
V3.02.14	20.5	138.5	-	94	-
V3.02.15	20.5	145.5	-	94	-
V3.02.16	20.5	149.5	-	90	-
V3.02.17	20.5	156.5	-	90	-
V3.02.18	20.5	74.5	-	90	-
V3.02.19	20.5	60	-	94	-
V3.02.20	22.5	56.5	-	95	-
V3.02.21	20.5	172	-	90	-
V3.02.22	32.5	117.5	-	94	-
V3.02.23	29.5	66.5	-	90	-
V3.02.24	20.5	117	-	90	-
V3.02.25	27	160	-	88	-
V3.02.26	20.5	105	-	94	-
V3.02.27	20	75	-	94	-
V3.02.28	20	127	-	94	-

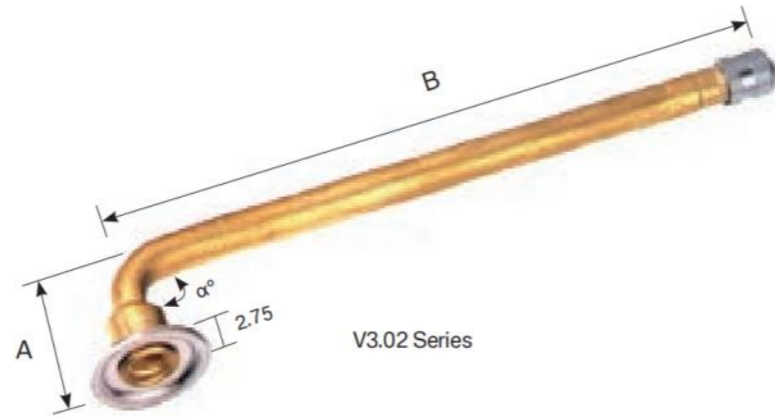

JT NO.	A	B	C	α°	β°
V3.04.1	20.5	32	37	90	138
V3.04.2	20.5	38	41.5	90	153
V3.04.3	20	59	38.5	94	163
V3.04.4	20	74	40	94	144
V3.04.5	20	76	47.5	90	153
V3.04.6	20	86	47.5	90	153
V3.04.7	20.5	30.5	38	90	154
V3.04.8	20.5	38.5	43	90	167
V3.04.9	20.5	45	47	90	194
V3.04.10	20.5	47	53	90	154
V3.04.11	20.5	47	63.5	90	154
V3.04.12	20.5	60.5	60.5	90	159
V3.04.13	20.5	60.5	67	90	159
V3.04.14	20.5	83.5	65	90	159
V3.04.15	20.5	42	38.5	90	120
V3.04.16	20	38	50	90	160
V3.04.17	20	65	45	90	160
V3.04.18	20	72	45	90	160
V3.04.19	20	80	45	90	160
V3.04.20	20	68	47	94	164
V3.04.21	20	83	57	94	154
V3.04.22	20	28	47	94	164
V3.04.23	20	48	57	94	164
V3.04.24	20	58	47	94	164
V3.04.25	20	80	47	94	164
V3.04.26	20	99	42	99	189

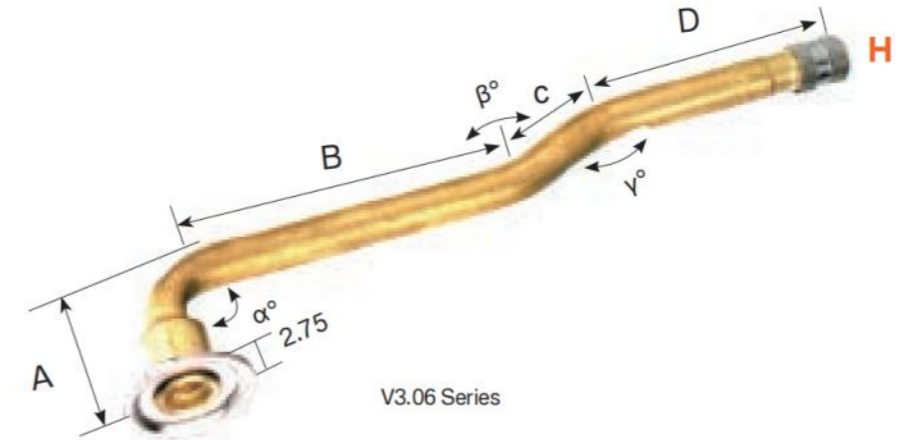
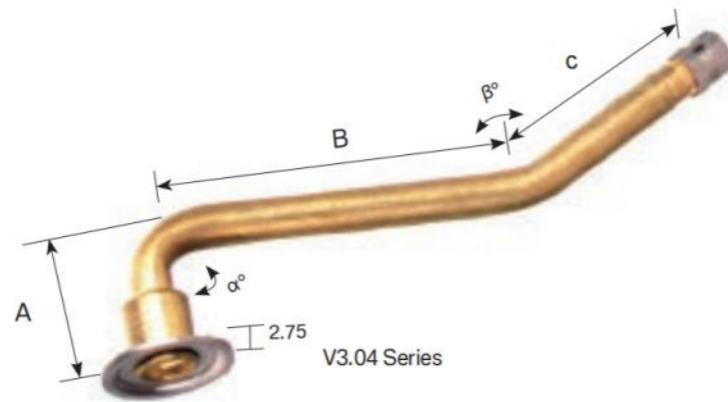

JT NO.	A	B	C	D	H	α°	β°	γ°
V3.06.1	20.5	30.5	19.5	35.5	17	90	139	139
V3.06.2	20.5	44.5	12	37.5	17	90	125	125
V3.06.3	20.5	46	20.5	47.5	17	90	140	140
V3.06.4	32.5	45.4	20.5	47.5	17	90	140	140
V3.06.5	20.5	62.5	19.5	49	17	90	139	139
V3.06.6	20	79.5	19.5	37.5	17	90	139	139
V3.06.7	20.5	45.5	18.5	42.5	17	90	137	137
V3.06.8	24.5	61.5	14.5	50.5	7.5	94	153	153
V3.06.9	20.5	67.5	19.5	54.5	17	90	139	139
V3.06.10	23.5	91.5	29.5	45.5	13.5	90	155	155
V3.06.12	23.5	71.5	19.5	25.5	11.5	90	150	150
V3.06.13	20	40	13	40	7	94	153	153
V3.06.14	20	50	13	40	7	94	153	153
V3.06.15	20	60	13	40	7	94	153	153
V3.06.16	20	62	13	50	7	94	153	153
V3.06.17	20	75	13	50	7	94	153	153

TR NO.	Ref.LENGTH (mm)	PARTS	
		CORE	CAP
TR1075A	$\Phi 22.5 \times 24 / 76 / 86^\circ$	9002#	DT
TR1076A	$\Phi 22.5 \times 24 / 86 / 86^\circ$		
TR1077A	$\Phi 22.5 \times 24 / 105 / 86^\circ$		
TR1078A	$\Phi 22.5 \times 24 / 127 / 86^\circ$		
TR1175A	$\Phi 22.5 \times 24 / 115 / 86^\circ$		
TR1177A	$\Phi 22.5 \times 24 / 95 / 86^\circ$		
TR1178A	$\Phi 22.5 \times 24 / 135 / 86^\circ$		
TR1179A	$\Phi 22.5 \times 24 / 141 / 86^\circ$		



Agricultural & Off The Road Valves

工程车 / 农用车专用气门嘴

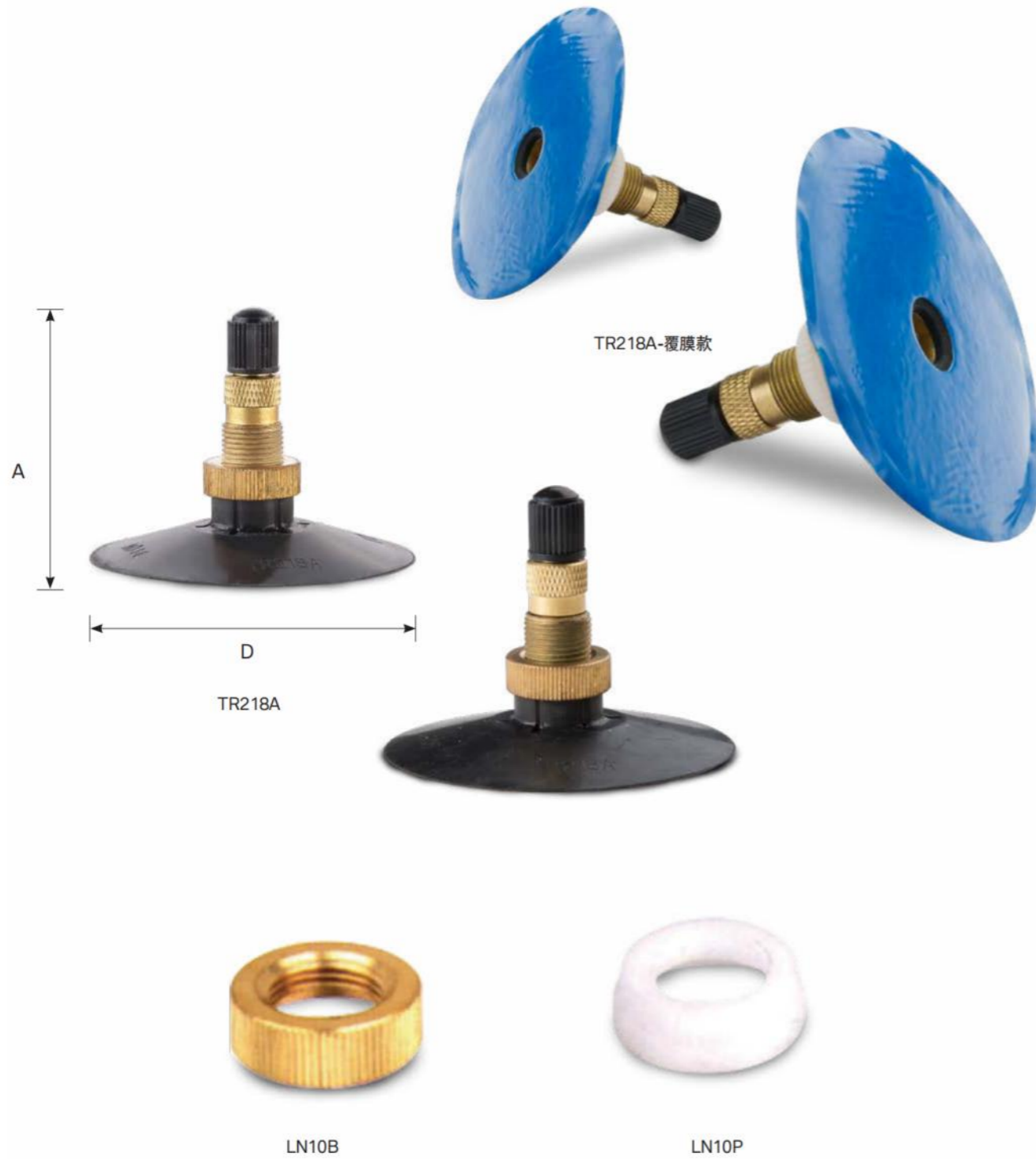

TR NO.	ETRTO NO	A	D	CORE HOUSING	LOCK NUT	CAP
TR218A	V4.01.1	27	63.5/82	TRCH3	LN10 or LN10EQ	VC618
TR220A	V4.01.2	35.5	63.5/82			

Agricultural & Off The Road Valves

工程车 / 农用车专用气门嘴



TRSP1000

TR NO.	A	B
TRSP1000	Φ70	5.6
	Φ82	
	Φ95	
JSP1	Φ70	8.2
	Φ82	
	Φ96	



TRSP4000

TR NO.	A	ETRTO NO
TRSP4000-114	114	TRSP4000
TRSP4000-110	110	V5.141
TRSP4000-80	80	V5.1402



VS-703R



VS-704R



TRAD4

TR NO.	A	B
V3-08-2	70	7
V3-08-3	80	8
V3-08-4	57	5
V9.05.1	95	7.2



TRJ NO.	V	A	W
TRJ1175B	36	108	82°
TRJ1075C	39	105	88°
TRJ1076B	32	83	86°
TRJ1076C	42	73	90°
TRJ1076D	56	59	90°
TRJ1076E	39	76	68°
TRJ1078B	39	118	82°
TRJ1078C	39	124	90°
TRJ1079B	39	133	88°

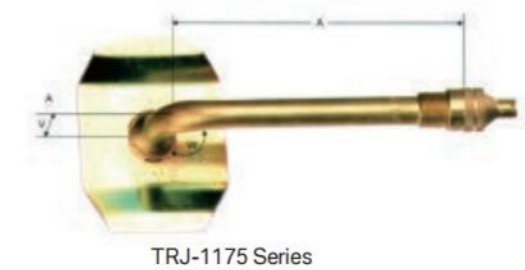

Rubber Based Tube Valves For Truck And Bus

大巴车 / 卡车内胎气门嘴

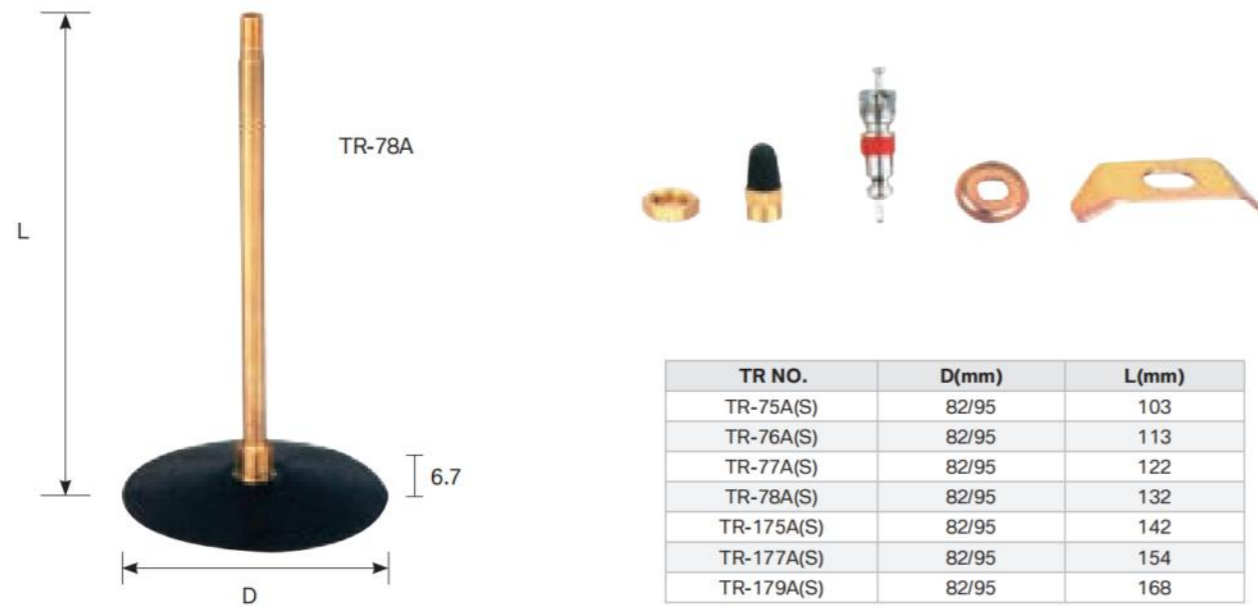

TR NO.	D(mm)	L(mm)
TR-75A(S)	82/95	103
TR-76A(S)	82/95	113
TR-77A(S)	82/95	122
TR-78A(S)	82/95	132
TR-175A(S)	82/95	142
TR-177A(S)	82/95	154
TR-179A(S)	82/95	168

Bicycle & Motorcycle Tube Valves

自行车 / 摩托车内胎气门嘴

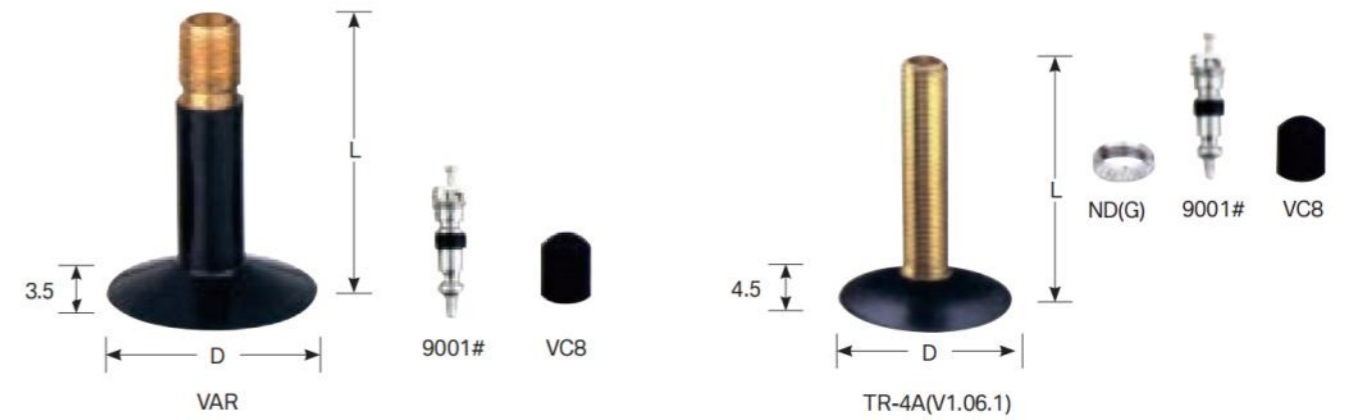

JT NO.	D	L
VAR-25	25	35
VAR-28	28	35
VAR-32	32	35
C4E-46x28	46x28	30

JT NO.	D	L
TR4A-25	25	33,40
TR4A-28	28	33,40
TR4A-32	32	33,40



TR NO.	D(mm)	L1(mm)	L2(mm)	α°
TR-75A	82/95	32	76	86
TR-76A	82/95	32	86	86
TR-177A	82/95	32	95	86
TR-77A	82/95	32	105	86
TR-175A	82/95	32	115	86
TR-78A	82/95	32	127	86
TR-179A	82/95	32	141	86

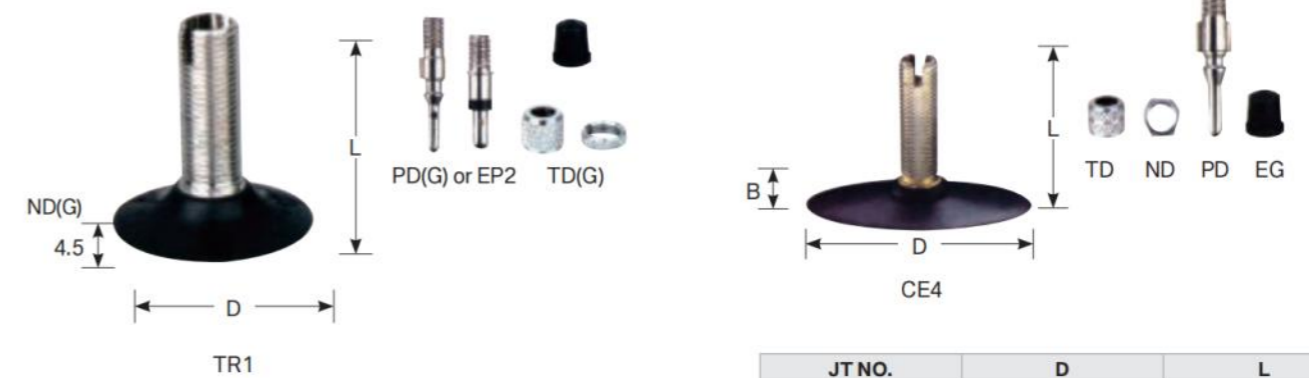

JT NO.	D	L
TR1-35L	28,32	35
TR1-40L	28,32	40

JT NO.	D	L
C4E-25	25	30
C4E-28	28	30
C4E-32	32	30
C4E-46x25	46x25	30
C4E-46x28	46x28	30

Bicycle & Motorcycle Tube Valves 自行车 / 摩托车内胎气门嘴

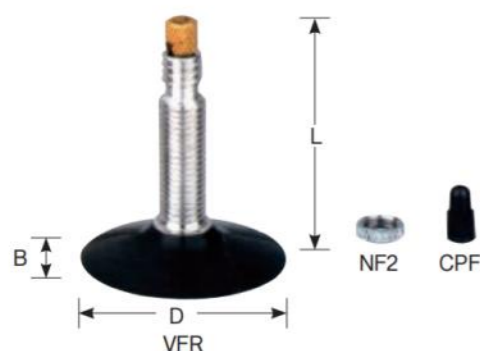

JT NO.	D	L
VFR-25	25	26.5,32,33,36,40,48,60
VFR-28	28	26.5,32,33,36,40,48,60
VFR-32	32	26.5,32,33,36,40,48,60

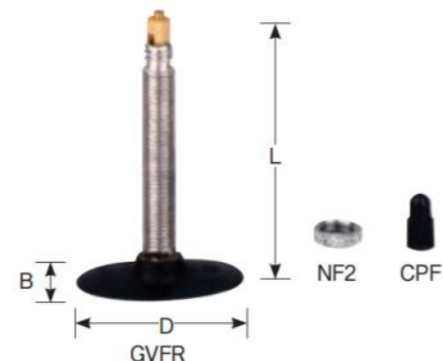

JT NO.	D	L
GVFR-25	25	26.5,32,33,36,40,48,60
GVFR-28	28	26.5,32,33,36,40,48,60
GVFR-32	32	26.5,32,33,36,40,48,60



JT NO.	D	L
TR4	45	34.5
TR4S	38	34.5



JT NO.	D	L
TR6N	45	34.5

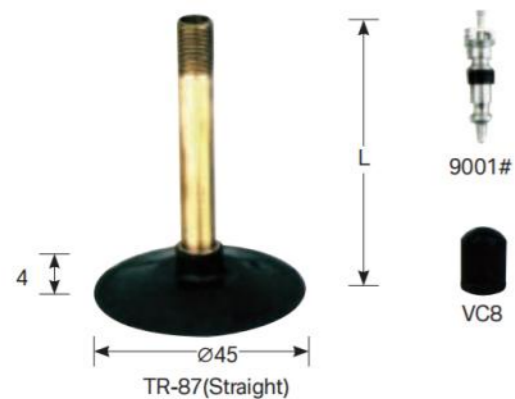

JT NO.	L
TR87(S)	48
JS87(S)	45
JS87C(S)	52.5
JS87N(S)	47
JS87CL(S)	56

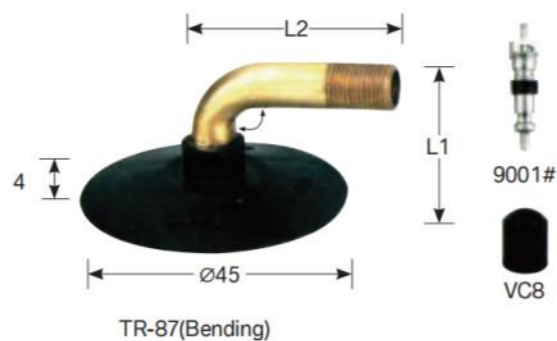

JT NO.	L1	L2
TR87	19	33
JS87	19	30
JS87P	19	27.5
JS87C	23.5	33
JS87N	21	30
JS87CL	30	30

Passenger Car & Light Truck Tube Valves 摩托车内胎气门嘴

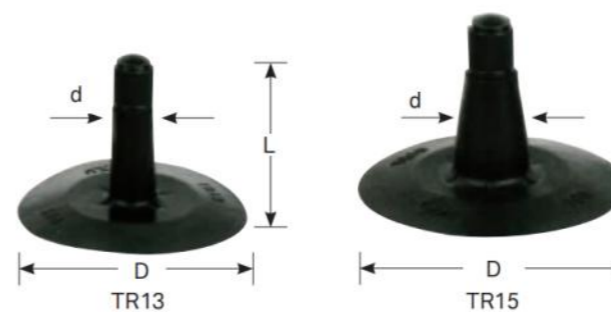

JT NO.	L	D	d
TR13	38	56	11.5
TR15	38	56	16.5

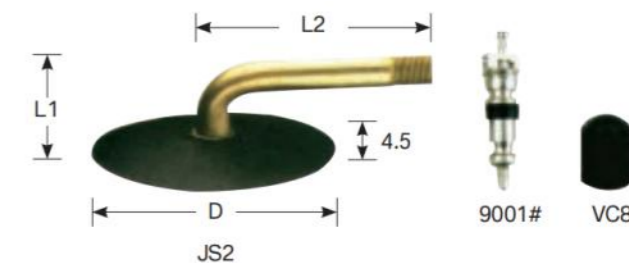

JT NO.	L1	L2	D	α
TR224A	30.5	33	56	90
JS2	30.5	33	56	70

British/German/American bicycle valve mouth 英式 / 德式 / 美式自行车气门嘴



Bicycle valve fitting 自行车气门嘴配件



Rubber Grommets 橡胶垫圈

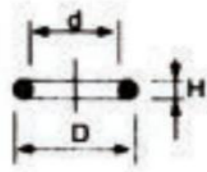
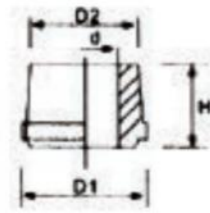
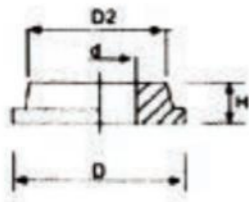
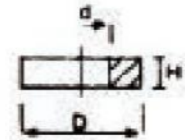

SJTNO.	OD (mm)	ID (mm)	M (mm)
HG1/R	7.8	3.5	1.8
HG2	16	7	3.5
HG4	15	7	3
HG7	12	7.2	2.5
V9.05.1	24	8	3

SJTNO.	OD (mm)	ID (mm)	M (mm)
RG7	22	12	9
RG16	25.4	17	5
RG22	25.4	17	6.5
RG46	22.5	10	8
RG59	14	7	4

SJTNO.	OD (mm)	ID (mm)	M (mm)
RG15/R	19	10	13
RG39	18	10	8
RG54	17	10	6.5/7.5
HRG1	16	7	6.5
HRG2	14	7	6
HRG4	15	8	5.5
RG522	19	10	10.5

SJTNO.	OD (mm)	ID (mm)	M (mm)
RG67	V9.11.6	4.5	1.8
RG66	V9.11.3	6	1.8
RG60	V9.11.5	9	1.9
V9.11.2	V9.11.2	20.7	2.6
V9.11.4	V9.11.4	15.6	2.6
V9.11.7	V9.11.7	11	2
V9.11.8	V9.11.8	8	1.9

Valve Cores 自行车法式气门芯



V002



V002-1

Valve Cores 气门芯



#9001 #9002 #9003 #9004

#9000 Series

内弹簧式短型气门芯，适用于1号芯腔(5V1)气门嘴；
Short valve core with inside spring, applied to tire valve with No. 1 core chamber(5V1).

螺纹 Thread	密封圈材质 Seal ring Material	密封垫材质 Gasket material	使用温度范围 Working Temp. Range	使用压力范围 Working Pressure Range	安装扭矩 Installation Torque
5V1	聚四氟乙烯 (Teflon)	硅橡胶 (SR)	-40°C ~ +120°C	0~1.5MPa	0.23N·m~0.34N·m



#8001 #8002 #8003 #8004

#8000 Series

外弹簧式长型气门芯，适用于1A号芯腔(5V1)气门嘴；
Long valve core with outside spring, applied to tire valve with No. 1A core chamber(5V1).

螺纹 Thread	密封圈材质 Seal ring Material	密封垫材质 Gasket material	使用温度范围 Working Temp. Range	使用压力范围 Working Pressure Range	安装扭矩 Installation Torque
5V1	聚四氟乙烯 (Teflon)	硅橡胶 (SR)	-40°C ~ +120°C	0~1.5MPa	0.23N·m~0.34N·m



#7001 #7002 #7003 #7004

#7000 Series

大芯腔短型气门芯，适用于2号芯腔(8V1)气门嘴；
Large bore short valve core, applied to tire valves with No.2 core chamber(8V1).

螺纹 Thread	密封圈材质 Seal ring Material	密封垫材质 Gasket material	使用温度范围 Working Temp. Range	使用压力范围 Working Pressure Range	安装扭矩 Installation Torque
8V1	聚四氟乙烯 (Teflon)	硅橡胶 (SR)	-40°C ~ +120°C	0~1.5MPa	0.34N·m~0.56N·m



#6000 Series

大芯腔长型气门芯，适用于 2 号芯腔 (8V1) 气门嘴；
Large bore long valve core, applied to tire valves with No.2 core chamber(8V1).

螺纹 Thead	密封圈材质 Seal ring Material	密封垫材质 Gasket material	使用温度范围 Working Temp. Range	使用压力范围 Working Pressure Range	安装扭矩 Installation Torque
8V1	聚四氟乙烯 (Teflon)	硅橡胶 (SR)	-40°C ~ +120°C	0~1.5MPa	0.34N·m~0.56N·m



#5000 Series 低铅气门芯

内弹簧式短型气门芯，适用于 1 号芯腔
Short Core with inner spring, applying to chamber 1 tire valve
含铅量低于 90PPM，符合 ROHS、REACH 标准
Pb%≤90PPM, Meet the standard of ROHS, REACH

螺纹 Thead	密封圈材质 Seal ring Material	密封垫材质 Gasket material	使用温度范围 Working Temp. Range	使用压力范围 Working Pressure Range	安装扭矩 Installation Torque
5V1	聚四氟乙烯 (Teflon)	硅橡胶 (SR)	-40°C ~ +120°C	0~1.5MPa	0.23N·m~0.34N·m



#H06C Series

适用于 1 号芯腔
Applying to chamber 1 tire valve
进排气速度快
Fast air flow rate

螺纹 Thead	密封圈材质 Seal ring Material	密封垫材质 Gasket material	使用温度范围 Working Temp. Range	使用压力范围 Working Pressure Range	安装扭矩 Installation Torque
5V1	聚四氟乙烯 (Teflon)	硅橡胶 (SR)	-40°C ~ +120°C	0~1.5MPa	0.23N·m~0.34N·m

家用空调截止阀用气门芯
Household air-conditioner valve cores



型号	螺纹 Thead	密封圈材质 Seal ring Material	密封垫材质 Gasket material	适用介质 Working Medium	使用温度范围 Working Temp. Range	使用压力范围 Working Pressure Range	安装扭矩 Installation Torque
9530	5V1	聚四氟乙烯 (Teflon)	氯丁胶 (CR)	R22 冷冻机油 Refrigeration Oil	-30°C ~ +120°C	0~3.5MPa	0.30N·m~0.40N·m
6100D	5V1	聚四氟乙烯 (Teflon)	氢化丁腈橡胶 (HNBR)	R410A、R407C、 冷冻机油 Refrigeration Oil	-30°C ~ +120°C	0~4.5MPa	0.30N·m~0.40N·m

汽车空调充注阀用气门芯
Auto air-conditioner charging valve cores



型号	螺纹 Thead	密封圈材质 Seal ring Material	密封垫材质 Gasket material	适用介质 Working Medium	使用温度范围 Working Temp. Range	使用压力范围 Working Pressure Range	安装扭矩 Installation Torque
VC01 (HNBR)	M6x0.75	氢化丁腈橡胶 (HNBR)	氢化丁腈橡胶 (HNBR)	R134a、冷冻机油 Refrigeration Oil	-30°C ~ +120°C	0~5.3MPa	0.40N·m~0.80N·m
VC01 (CR)	M6x0.75	氯丁胶 (CR)	氯丁胶 (CR)	R22 冷冻机油 Refrigeration Oil	-30°C ~ +120°C	0~5.3MPa	0.40N·m~0.80N·m
VC02	M6x1	氢化丁腈橡胶 (HNBR)	-	R134a、冷冻机油 Refrigeration Oil	-30°C ~ +120°C	0~3.5MPa	0.40N·m~0.80N·m
VC03	M8x1	氢化丁腈橡胶 (HNBR)	氢化丁腈橡胶 (HNBR)	R134a、冷冻机油 Refrigeration Oil	-30°C ~ +120°C	0~5.3MPa	0.40N·m~0.80N·m
VC04	M8x1	氢化丁腈橡胶 (HNBR)	氢化丁腈橡胶 (HNBR)	R134a、冷冻机油 Refrigeration Oil	-30°C ~ +120°C	0~5.3MPa	0.40N·m~0.80N·m
VC05	M10x0.75	氢化丁腈橡胶 (HNBR)	氢化丁腈橡胶 (HNBR)	R134a、冷冻机油 Refrigeration Oil	-30°C ~ +120°C	0~5.3MPa	0.40N·m~0.80N·m
VC07	M8x1	聚四氟乙烯 (Teflon)	氢化丁腈橡胶 (HNBR)	R134a、冷冻机油 Refrigeration Oil	-30°C ~ +120°C	0~5.3MPa	0.40N·m~0.80N·m
T10	5V1	聚四氟乙烯 (Teflon)	丁腈橡胶 (NBR)	-	-	-	0.23N·m~0.34N·m

Valve Caps 气门嘴帽

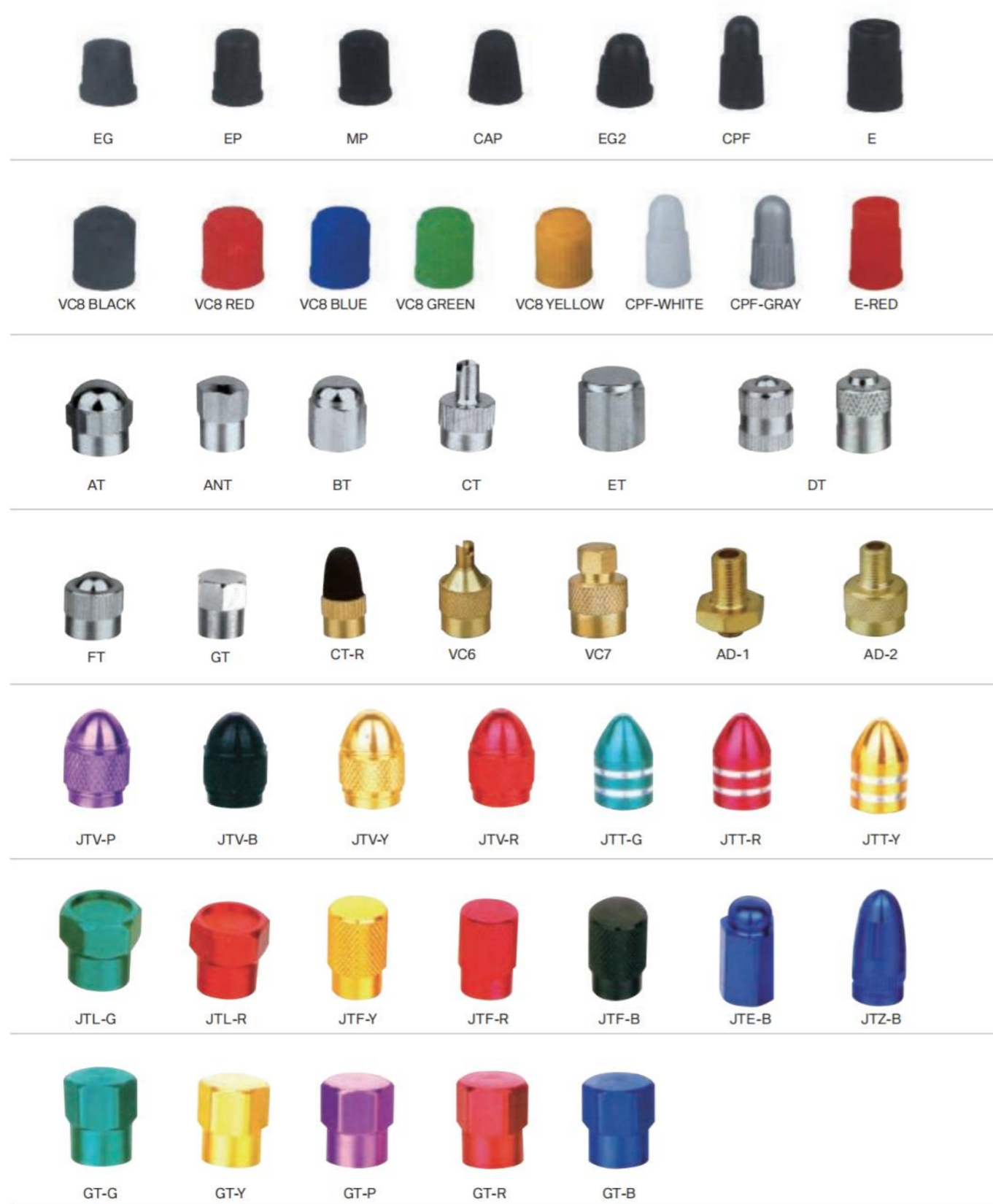

Valve Caps 气门嘴帽



Valve Caps 气门嘴帽

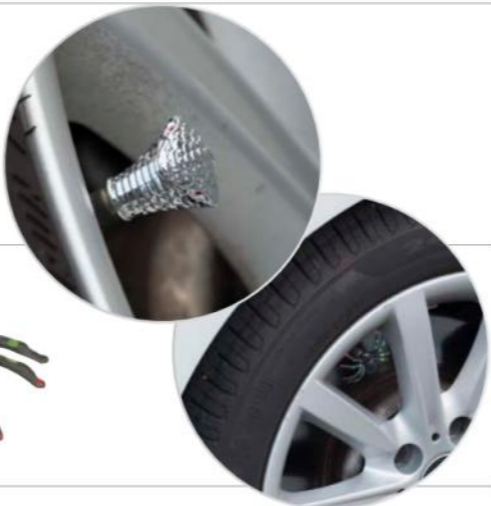

Holder For Flexible Rubber Valve Extensions

延长管单夹 / 充气嘴



JTFVE1



JTFVE2



JTFVE3

Bent Metal Type-Nickel/Chrome/ Dip(Brass)

金属打弯充气嘴

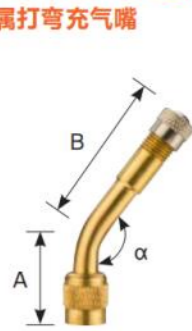

JT36-135°

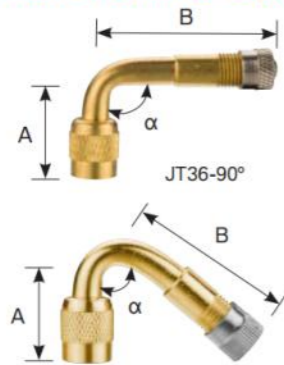

JT36-45°

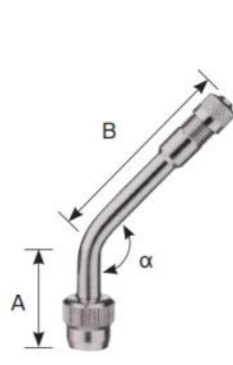

JT36M-135°

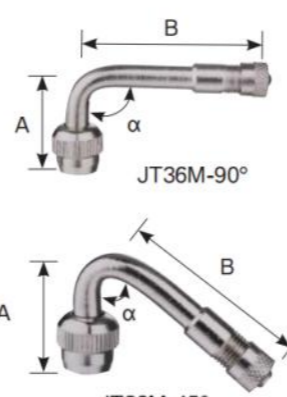

JT36M-45°

JT NO.	A(mm)	B(mm)	α°
JT36-135°	24.5	34	135
JT36-90°	24.5	34	90
JT36-45°	24.5	34	45

JT NO.	A(mm)	B(mm)	α°
JT36M-135°	25	34	135
JT36M-90°	25	34	90
JT36M-45°	25	34	45

Scooter/Balancing car inflatable extension

滑板车 / 平衡车充气延长管

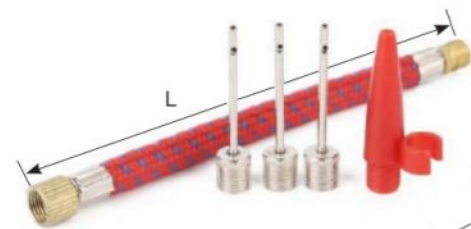

BVE-1



BVE-2



BVE-3

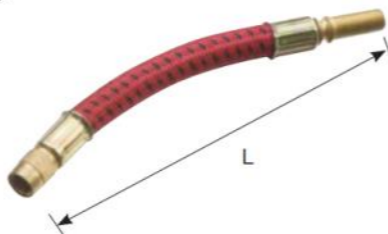

BVE-4

JT NO.	L(mm)
BVE-1	115
BVE-2	125
BVE-3	160
BVE-4	150

Flexible Rubber Valve Extensions

橡胶延长管



BVE-5CHUCK



Stainless Steel Braided Flexible Rubber Valve Extensions

金属不锈钢编织延长管



JT NO.	DESCRIPTION	LENGTH(mm)	Φ(mm)
JT65RM	Extension	65	12/10
JT125RM		125	12/10
JT180RM		180	12/10
JT210RM		210	12/10
JT250RM-FVE1		250	12/10
JTMU	EXTENSION WITH U-SHAPE CLIP	210	12/10
JTFBE		250	12/10

Flexible Rubber Valve Extensions 橡胶延长管



JT NO.	DESCRIPTION	LENGTH(mm)	Φ(mm)
JT75R	Extension	75	12/10
JT100R		100	12/10
JT125R		125	12/10
JT150R		150	12/10
JT180R		180	12/10
JT210R		210	12/10
T250R		250	12/10
JT270R		270	12/10
JT300R		300	12/10
JT210R-FVE1		210	12/10
JT562 9503	Extension	230	12
JT562 9510		320	12
JT562 9527		360	12
JT562 9541		555	12

Valve Extensions 延长帽

JT NO.	EFF.LENGTH (L1)	TOTAL LENGTH(L)
JT13M	13	21
JT19M	19	28
JT32M	32	41

JT NO.	EFF.LENGTH (L1)	TOTAL LENGTH(L)
JT13P	13	21
JT19P	19	28
JT32P	32	41
JT38P	38	46



Straight Metal Type 金属延长杆

JT NO.	REF. NO. (RC NO.)	GENERAL LENGTH (mm/in)(L)	EFF.LENGTH (mm/in.)(L1)
JT30MT	V2412	40	30
JT50MT	V2414	60	50
JT66MT	V2416	76	66
JT76MT	V2418	86	76
JT90MT	V2420	100	90
JT100MT	V2422	110	100
JT115MT	V2424	125	115
JT130MT	V2426	140	130
JT140MT	V2428	150	140
JT152MT	V2430	162	152

JT NO.	REF. NO. (RC NO.)	GENERAL LENGTH (mm/in)(L)	EFF.LENGTH (mm/in.)(L1)
JT30ML	V2512	56	30
JT50ML	V2514	76	50
JT66ML	V2516	92	66
JT76ML	V2518	102	76
JT90ML	V2520	116	90
JT100ML	V2522	126	100
JT115ML	V2524	141	115
JT130ML	V2526	156	130
JT140ML	V2528	166	140
JT152ML	V2530	178	152



Straight Plastic Type 塑料延长杆

JT NO.	REF. NO. (RC NO.)	GENERAL LENGTH (mm/in)(L)	EFF.LENGTH (mm/in.)(L1)
JT33PT/PT-B	AG2190.051	51	33
JT53PT/PT-B	AG2190.071	71	53
JT77PT/PT-B	AG21 90.095	95	77
JT97PT/PT-B	AG2190.115	115	97
JT107PT/PT-B	AG2190.125	125	107
JT132PT/PT-B	AG2190.150	150	132
JT152PT/PT-B	AG2190.170	170	152
JT162PT/PT-B	AG2190.180	180	162
JT169PT/PT-B		187	169

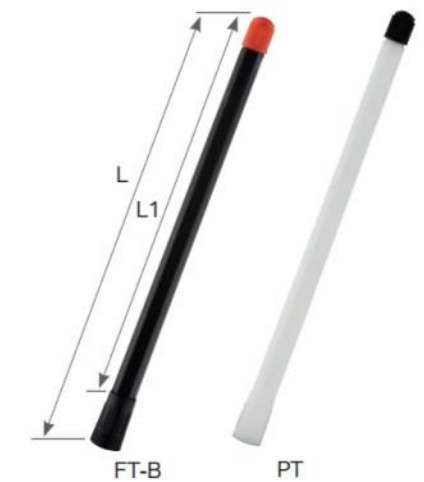

Tire repair strip

补胎胶条

String-type inserts

String-type inserts can be used in passenger or truck, radial or bias-ply tires. Made of a butyl rubber, these inserts are very strong, allowing easy insertion through steel belted radials. String-type inserts are temporary repairs, sealing by compression only. Use any closed eye needle, to install all other string-type inserts, use any end-slot needle (passenger length for 4" inserts; truck length for 8" inserts).

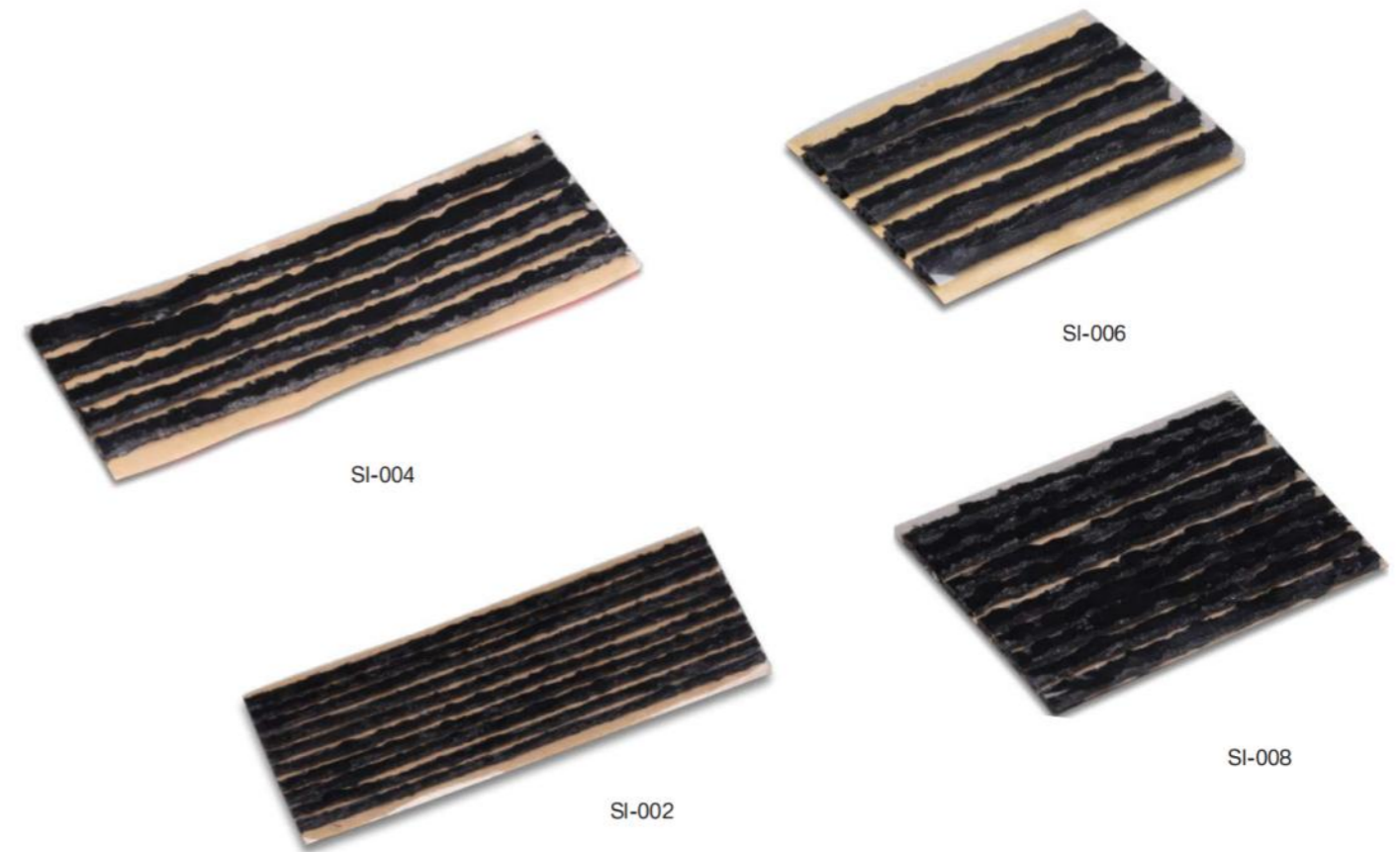
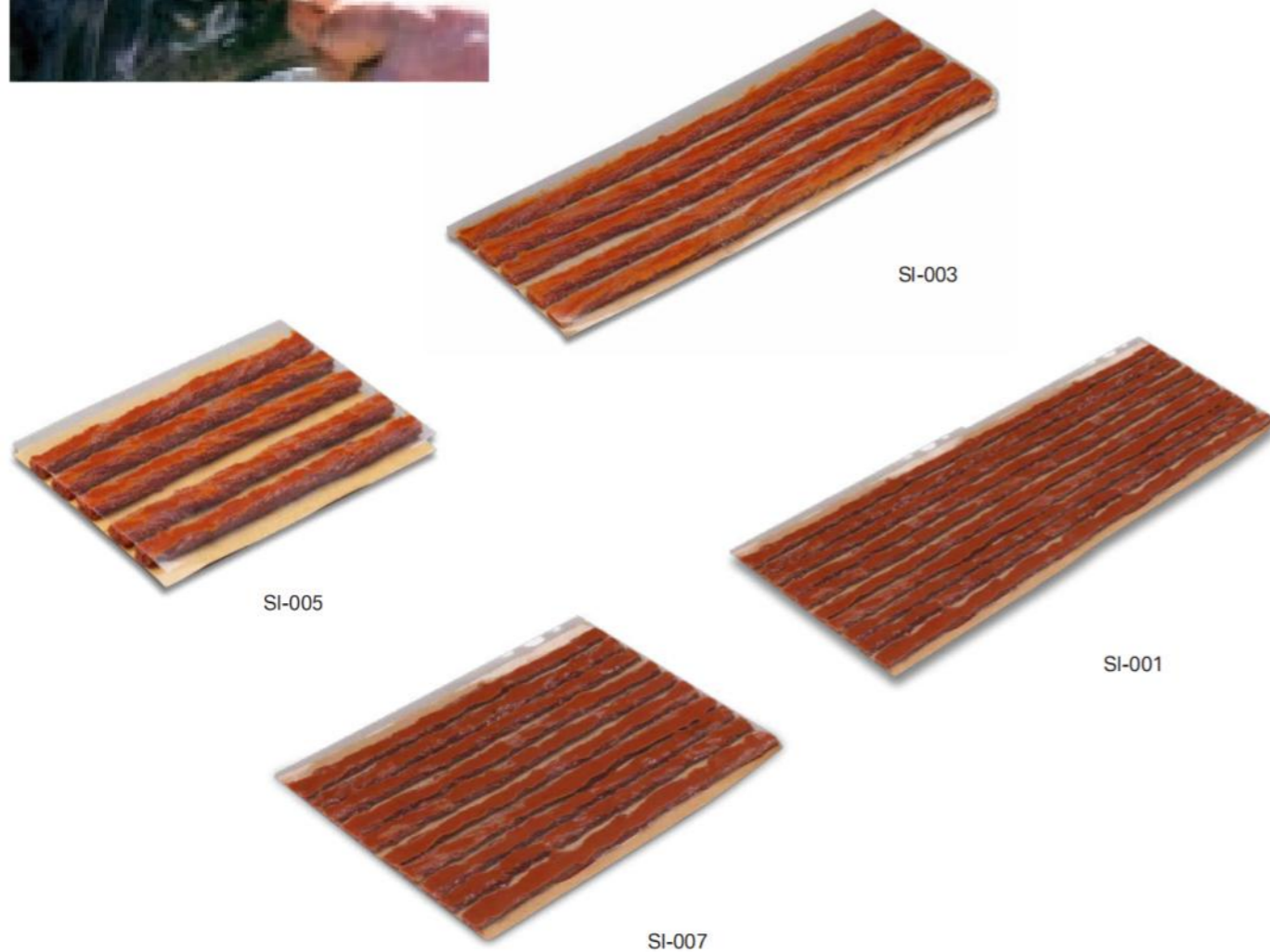

PART NO.	DESCRIPTION	DIA	LENGHT(inches)/(mm)		BOX QTY	CARTON QTY
SI-001	Brown string	Φ3.5mm	8	200	50/60	50
SI-003	Brown string	Φ6mm	8	200	50/60	50
SI-005	Brown string	Φ6mm	4	100	50/60	50
SI-007	Brown string	Φ3.5mm	4	100	50/60	50

PART NO.	DESCRIPTION	DIA	LENGHT(inches)/(mm)		BOX QTY	CARTON QTY
SI-002	Black string	Φ3.5mm	8	200	50/60	50
SI-004	Black string	Φ6mm	8	200	50/60	50
SI-006	Black string	Φ6mm	4	100	50/60	50
SI-008	Black string	Φ3.5mm	4	100	50/60	50

AIR CHUCKS
充气夹头



No.	Part No.	Description
1	EAC128-1	8mm
2	EAC128-2	8mm
3	EAC128-3	8mm



No.	Part No.	Description
1	EAC112-1	Nickel Plated
2	EAC112-2	Acid Pickling

AIR CHUCKS
充气夹头

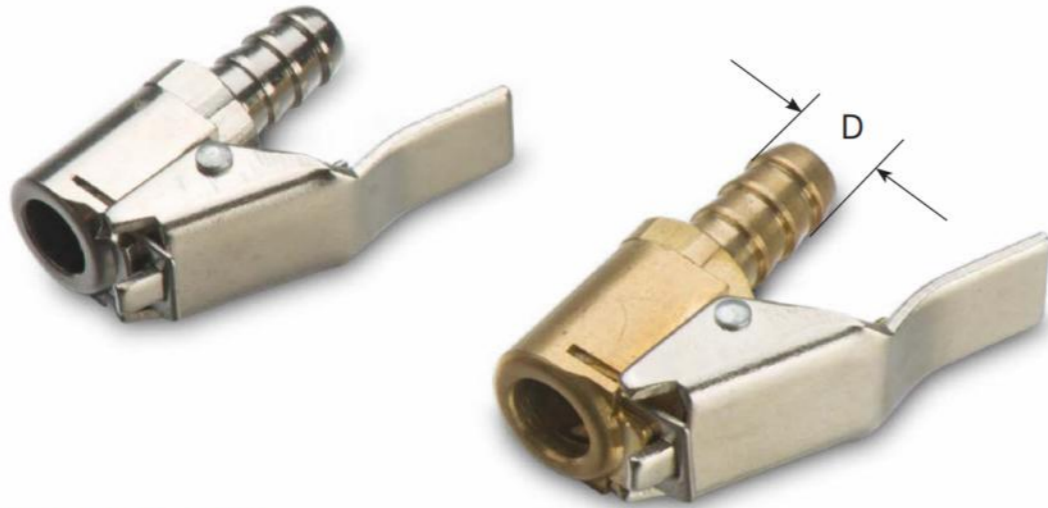

Clip-On Air Chuck, with Hose Barb

No.	Part No.	Description	Hose Barb Dia.D
1	EAC106-1	Open,Chrome Plated	6mm
2	EAC106-2	Closed,Chrome Plated	6mm
3	EAC106B-1	Open,Brass Finish	6mm
4	EAC106B-2	Closed,Brass Finish	6mm
5	EAC108B-1	Open,Brass Finish	8mm
6	EAC108B-2	Closed,Brass Finish	8mm
7	EAC108-1	Open,Chrome Plated	8mm
8	EAC108-2	Closed,Chrome Plated	8mm

Brass ball foot air chuck, 1/4" FPT, whit clip



No.	Part No.	Description
1	EAC114-1	Nickel Plated
2	EAC114-2	Quick Couping

Clip-on air chuck, with 1/4" FPT



No.	Part No.	Description
1	EAC114L-1	Acid Pickling
2	EAC114L-2	Nickel Plated

Brass ball foot air chuck, with 1/4" FPT



No.	Part No.	Description
1	EAC125-1	Acid Pickling
2	EAC125-2	Nickel Plated

Brass ball foot air chuck, with 1/4" FPT



No.	Part No.	Description
1	EAC112-1	Brass
2	EAC112-2	Zinc

Thumb-lock air chuck



No.	Part No.	Description
1	EAC108T-1	6mm
2	EAC108T-2	8mm

Valve Core Tools 气门芯工具



VT-027-B



VT-027-R



VT-027-Y



VT-008



VT-009



VT-007



VT-011



VT-010A



VT-010B



VT-015A



VT-015B



VT-015C



VT-015D



VT-020



VT-003



VT-014



VT-028

PART NO.	DESCRIPTION
VT-003	2 in 1 Valves Stem Tool
VT-007	Valve Core Tool Long
VT-008	Double-head Valve Core Tool For Standard and Large Bore
VT-009	Double-head Valve Core Tool
VT-010A	Valve Core Tool Short
VT-010B	Valve Core Tool Long
VT-011	Valve Core Tool Short
VT-014	Valve Core Tool
VT-015A	Rubber Straight Handle Valve Core Tool
VT-015B	Valve Core Extractor
VT-015C	Rubber Straight Handle Valve Core Tool with Cap
VT-015D	Rubber Straight Handle Valve Core Tool
VT-020	Aluminum Handle Valve Core Tool
VT-025	2 in 1 Valve Core Tool with Clip
VT-027	Double Head Aluminum Handle Valve Core Tool
VT-028	Double Head Valve Core Tool With Magnet
VT-029A	Aluminum Handle Valve Core Tool with Magnet Long
VT-029B	Aluminum Handle Valve Core Tool with Magnet Short
VT-031	Torque Valve Core Tool for TPMS Valve



All-Purpose Valve Tools 四合一工具

PART NO.	DESCRIPTION
VT-001	4-Way Valve Stem Tool Standard
VT-001L	4-Way Valve Stem Tool Large
VT-002	Multi-Use Valve Stem Tool
VT-004	4-Way Valve Stem Tool Black
VT-005	4-Way Valve Stem Tool Black
VT-006	4-Way Valve Stem Tool Black



Valve Installation Tools 气门嘴拉拔工具

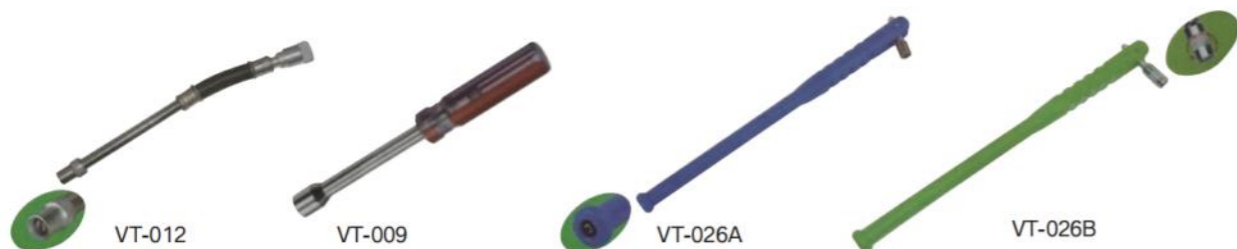

Part NO.	DESCRIPTION
VT-009	Hexagonal ScrJDriver
VT-016	Chain Type Valve Fishing Tool
VT-017	Valve Fishing Tool
VT-018	3 in 1 Valve Fishing Tool Long
VT-019	3 in 1 Valve Fishing Tool Short
VT-021	Heavy Duty Valve Stem Tool

Part NO.	DESCRIPTION
VT-022	Heavy Duty Valve Stem Tool with Rubber Protector
VT-023	Heavy Duty Valve Stem Tool with Plastic Protector
VT-024	Heavy Duty Valve Stem Tool
VT-026A	2 in 1 Plastic Handle Valve Stem Tool
VT-026B	Plastic Handle Valve Stem Tool with Rubber Head
VT-012	2 in 1 Valve Stem Tool with Rubber Extender

Clip-On Wheel Weight Pliers 平衡钳



Part NO.	DESCRIPTION
EHG001A	Forge Wheel Weight Pliers Nickel Plating
EHG-001B	Forge Wheel Weight Pliers Black
EHG-001C	Forge Wheel Weight Pliers
EHG-002	Forge Wheel Weight Pliers Nickel Plating
EHG-003	Whell Weight Pliers
EHG-034	Heavy-Duty Wheel Weight Pliers
EHG-001AC	Plastic Cap For Forge Weight Pliers
EHG-003AC	Cap Accessories for EHG-003

Adhesive Wheel Weight Tools 塑料平衡块铲刀



A high-impact plastic chisel designed to remove adhesive wheel weights quickly without damaging expensive. Simply pry the weight off with a light tap of a hammer. The edge can be re-sharpened for extended use

Part NO.	DESCRIPTION
EHG-031A	Adhesive wheel weight removal tool Big handle
EHG-031B	Adhesive wheel weight removal tool Small handle

Wheel Weight Hammer 平衡块榔头



Part NO.	DESCRIPTION
EHG-015	Non-Lead Clip-on Truck Wheel weight Hammer
EHG-033	Dead Blow Hammer 240Z(1-1/2LB)

Stitchers 压实滚轮



Part NO.	Roller dia(mm)	Thickness(mm)
RT-008A/B/C/D	38	3/4/5/6
RT-009	50	6
RT-018	38	42
RT-021A/B/C/D/E/F	38	2/2.5/3/4/5/6
RT-020	2 in 1 Metal Tire Stitcher 150mm*30mm	

Scrapers 刮刀



Part NO.	DESCRIPTION
RT-010	Hoe Style Inner Liner Scraper
RT-011	Blade Style Inner Liner Scraper

Skiving Knives 橡胶割刀



Part NO.	DESCRIPTION
RT-016A	X2T Taper skiving knife
RT-016B	X1YX Extre curve sharp skiving knife
RT-016C	X3N round point flexible blade skiving knife

Applicators 圆头洗车刷



Part NO.	DESCRIBE	HEAD DIA(mm)	Hair Lenght(mm)	Pole dia(mm)	Pole Length(mm)
RT-074A-2	2#	19.5	38	9	160
RT-074A-4	4#	24	38	10	160
RT-074A-6	6#	29.5	38	10.5	160
RT-074A-8	8#	35	38	13	162
RT-074A-10	10#	38	44	16.5	170
RT-074A-12	12#	43	44	17	170
RT-074A-14	14#	48	44	18	180
RT-074A-16	16#	54.5	44	19.5	180
RT-074A-20	20#	65	51	21.5	185
RT-074A-22	22#	69.5	51	21.5	185
RT-045	Large	46	45	28	390
RT-075	Cotton Tire Swab				

Tire crayon 轮胎蜡笔



Part NO.	DESCRIPTION
RT-006	Tire Crayon Holder
RT-002W	White Color Tire Crayons
RT-002Y	Yellow Color Tire Crayons

Wheel hub protector 轮毂保护套

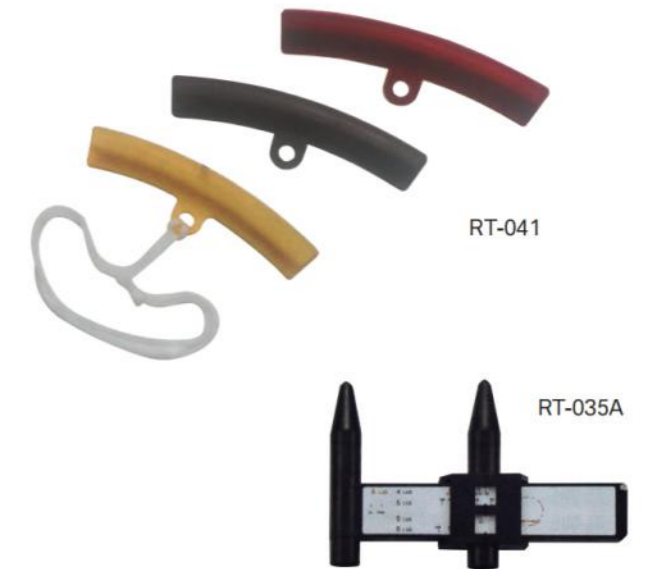

Part NO.	DESCRIPTION
RT-035A	Plastic PCD Gauge
RT-041	Tire Mounting Protector

Tire repair tools
轮胎修补工具



Needles for selection
12 types steel (45#) needles heat treatment

Tire repair tools
轮胎修补工具



TRK-002

TRK-004

TRK-006



TRK-008

TRK-010

TRK-011

Part NO.	DESCRIPTION
TRK-002	1pc power T-handle scrJT probe tools/1pc power T-handle plugger/1pc 12ml rubber cement/5pcs 4" black string
TRK-004	1pc pistol handle probe tool/1pc pistol handle plug insert tool/1pc 12ml rubber cement/5pcs 4" black string
TRK-006	1pc pistol handle probe tool/1pc pistol handle plug insert tool/5pcs 4" black string
TRK-008	1pc power T-handle plugger/1pc scrJT probe needle/1pc replacement tool
TRK-009	50pcs 4" black string
TRK-010	1pc metal T-handle scrJT probe tools/1pc metal T-handle plugger/1pc 12ml rubber cement/5pcs 4" black string
TRK-011	1pc metal T-handle scrJT probe tools/1pc metal T-handle plugger/1pc L-type wrench/5pcs 4" black string



TRKE-046
42PCS EMERGENCY TIRE REPAIR KIT
1PC Zinc-Alloy T-handle Tire Seal Insertion Tool
1PC Zinc-Alloy T-handle Spiral Probe Tool
10PCS 8"(200mm)Self-vulcanization Plugs
10PCS 4"(100mm)Self-vulcanization Plugs
1PC Small Pencil Type Pressure Gauge(10-50psi)
1PC 4-Way Valve Stem Tool
4PCS Standard Valve Cores
4PCS Brass Hex Valve Caps
4PCS Plastic Valve Caps
2PCS L-type Hex Tools
1PC Plastic Storage Box
1PC Lube
1PC Knife
1PC Blow Mould Case



TRKE-001
27PCS EMERGENCY TIRE REPAIR KIT
1PC Zinc-Alloy T-handle Tire Seal Insertion Tool
1PC Zinc-Alloy T-handle Spiral Probe Tool
20PCS 8"(200mm)Self-vulcanization Plugs
2PCS L-type Hex Tools
1PC Lube
1PC Knife
1PC Blow Mould Case



TRKE-003C
25PCS EMERGENCY TIRE REPAIR KIT
1PC Small Heavy-duty T-handle Insert Tool
1PC Small Heavy-duty T-handle Rasp Tool
1PC L-type Hex Tool
20PCS 4"(100mm)Self-vulcanization Plugs
1PC Knife
1PC Blow Mould Case



TRKE-003C
25PCS EMERGENCY TIRE REPAIR KIT
1PC Plastic T-handle Insert Tool
1PC Plastic T-handle Rasp Tool
1PC L-type Hex Tool
20PCS 4"(100mm)Self-vulcanization Plugs
1PC Knife
1PC Blow Mould Case



TRKE-004A
28PCS EMERGENCY TIRE REPAIR KIT
1PC Heavy-duty T-handle Insert Tool
1PC Heavy-duty T-handle Rasp Tool
1PC Square Insert Needle
2PCS L-Type Hex Tool
20PCS 4"(100mm)Self-vulcanization Plugs
1PC Knife
1PC Lube
1PC Blow Mould Case



TRKE-003B
25PCS EMERGENCY TIRE REPAIR KIT
1PC Small Heavy-duty T-handle Insert Tool With Handle Coated
1PC Small Heavy-duty T-handle Rasp Tool With Handle Coated
1PC L-type Hex Tool
20PCS 4"(100mm)Self-vulcanization Plugs
1PC Knife
1PC Blow Mould Case



TRKE-005
29PCS EMERGENCY TIRE REPAIR KIT
1PC Plastic T-handle Insert Tool
1PC Plastic T-handle Reamer
20PCS 4"(100mm)Self-vulcanization Plugs
1PC Pencil Tire Pressure Gauge 10-100psi
1PC 12ml Rubber Cement
1PC Metal Buffing Tool
2PCS Patches
1PC Knife
1PC Plastic Storage Bos



tread depth gauges 轮胎花纹刻度尺



RT-046



RT-048



RT-077



RT-014

Part NO.	DESCRIPTION
RT-012A	Plastic Tread Depth Gauge White Scale Bar
RT-012C	Aluminium Tread Depth Gauge White Scale Bar
RT-013A	Stainless Steel Tread Depth Gauge
RT-013B	Stainless Steel Tread Depth Gauge

Part NO.	DESCRIPTION
RT-014	OTR Tread Depth Gauge,32NDS /0-192MM
RT-046	Digital Tread Depth Gauge
RT-048	OTR Tread Depth Gauge
RT-077	Plastic Tread depth Gange with Key Ring

Tyre lever 轮胎撬棒



EHG-038A



PART NO.	DESCRIPTION
TL-01/02/03/04/05	12"/16"/18"/20"/25"

Tire Mount/Demount Tools 轮胎安装 / 拆卸工具



EHG-12320



EHG-12322

Tire Inflator Gauges 胎压枪



ECG-019



ECG-020



ECG-021



ECG-022

Tire Inflator Gauges 胎压枪



ECG-023



ECG-024



ECG-025



ECG-026



ECG-027



ECG-028



ECG-029



ECG-030



ECG-031

Tire Pressure Gauges 胎压表



ECG-032



ECG-033



ECG-034



ECG-035



ECG-036



ECG-037

PART #	DESCRIPTION
ECG-032	Long chuck with hose, 1/4" coupler
ECG-033	Long chuck with hose, 1/4" coupler
ECG-034	Dial gauge to brass clamp chuck with hose
ECG-035	Digital tire gauge with long chuck and hose
ECG-036	Tire gauge with all purpose brass chuck
ECG-037	Long straight bar gauge with protector