

**HYDRAULIC IRONWORKER**

**HIW-90 (Q35Y-20)**

**OPERATION MANUAL**

**(SM)**

**THE PEOPLE'S REPUBLIC OF CHINA**

**HYDRAULIC IRONWORKER**  
**HIW-90 (Q35Y-20)**

**TEST CERTIFICATION**

**(ZM)**

**THE PEOPLE'S REPUBLIC OF CHINA**

The machine has been examined to be qualified and approved to be delivery.

Serial Number:

Director of Examination Department:

Director of Workshop:

Date:

**HYDRAULIC IRONWORKER**

**HIW-90 (Q35Y-20)**

**PACKING LIST**

**(ZD)**

**THE PEOPLE'S REPUBLIC OF CHINA**



# Contents

- 1、 General View of Machine
- 2、 Technical Data
- 3、 Main Use
- 4、 Performance & Feature
- 5、 Construction
- 6、 Hydraulic System
- 7、 Electric System
- 8、 Hoisting, Installation & Preparation Before Trial Running
- 9、 Lubrication System
- 10、 Adjustment
- 11、 Trial Running & Operation
- 12、 Safety & Maintenance
- 13、 List of Wearing Parts and Outsourcing Parts
- 14、 List of Accessories Furnished of the Machine

ONE、 General View of Machine



Two、Technical Data

HYDRAULIC IRONWORKER MODEL:DIW-90 (HIW-90)

NO		Item	Unit	Q35Y-20
				HIW-90
1	shearing plate	Angle of shear	°	8°
		Max.shearing thickness	mm	16
		Flat bar	(W×T)	480×10
mm	330×20			
2	shearing bar	Round steel	mm	50
		Square bar	mm	50×50
		90°shearing of equal-angle bar	mm	140×140×12
		45°shearing of equal-angle bar	mm	50×50×5
		H-beam	mm	150×150
		I beam steel	mm	160×86×6
		channel steel	mm	160×60×6.5
3	notching	Thickness	mm	13
		Width	mm	57
		Depth	mm	100
4	punching hole	Max.punching thickness	mm	20
		Max.diameter of punching	mm	30
		Punching force	Ton	90
		Depth of throat	mm	355
		Max.length of cylinder stroke	mm	80
		Stroke times	times/min	5-22
5		Material strength	N/mm <sup>2</sup>	≤450
6		Motor power	KW	5.5
7		Overall dimensions (L×W×H)	mm	1860×790×1900
8		Net. weight	KG	2200

Q35Y-20 H.S.W	SM	
	Total 30 pages	Page 4

### Three、 Main Use

The machine is mainly used for cutting flat bar, profile, steal punching holes and notching. It can be widely used in shipyard, eclectic, bridge. Auto-mobile, hosting & transportation, metal construction and other machinery factories etc.

### Four、 Performance & Features

Flat bar cutting, profiled steal cutting, punching hole and notching work can be performed on the machine within the rated specification、 with extra equipment, the machine is able to cut, punch and bend in special shape.

The machine adopts hydraulic driving system and has a perfect structure, with light weight and low noise, stable performance and overload protecting devices.

### Five、 Construction

1) The bed can be seen in fig.1

The bed of the machine is composed of body, seat, bracket for section, bracket for angle and cutting table.

The body and the seat are of welded constructions, others are bolt-connected ones which give the machine great strength and of rigidity and allow easy dismounting during repairing the machine.

Q35Y-20 H.S.W	SM	
	Total 30 pages	Page 5

## 2) Section Cutting Station (Fig.2)

This station is fitted as standard with blades which is a solid structure and has four apertures to cut angle, square, flat bars and notch steel plates with extra tooling's on the square and round bars cutting apertures channel, and joist bars cutting also be performed The beam is connected with the kit cylinder of which the top end is hinged the frame driving by the oil cylinder, the beam swings to perform cutting.

The upper notching blade is fixed on the beam's here are 3 lower blades on both side can be adjusted to allow sufficient cutting clearance.

A side gauge and a back gauge are fitted on the notching table to allow the plate to be notched on the correct position.

## 3) Punching Hole (Fig.3)

The punch is fixed on the lower end of the piston rod of the oil cylinder with locking nut and the die is fixed in the adaptor. After the punch and die are aligned each other, the bolts should be tightened. To punch square and long round hole, there is a guide on the side surface of the piston rod, beside, a long round positioning slot is milled on the pad and the top of the punch to prevent the punch form being turned. With additional tooling on this station, bending, tube notching, louver punching, large whole punching, channel, joist, web punching work can all be performed.

## 4) Hold down device

There is pump for holding down in the plate shearing position and angle shearing position. So that does not need to adjust manual, conveniently and save effort.

The hold down device in round and square steel shearing position, It can compaction the round and square bar and then shearing by adjusting the workpiece in the round and square bar shearing position.

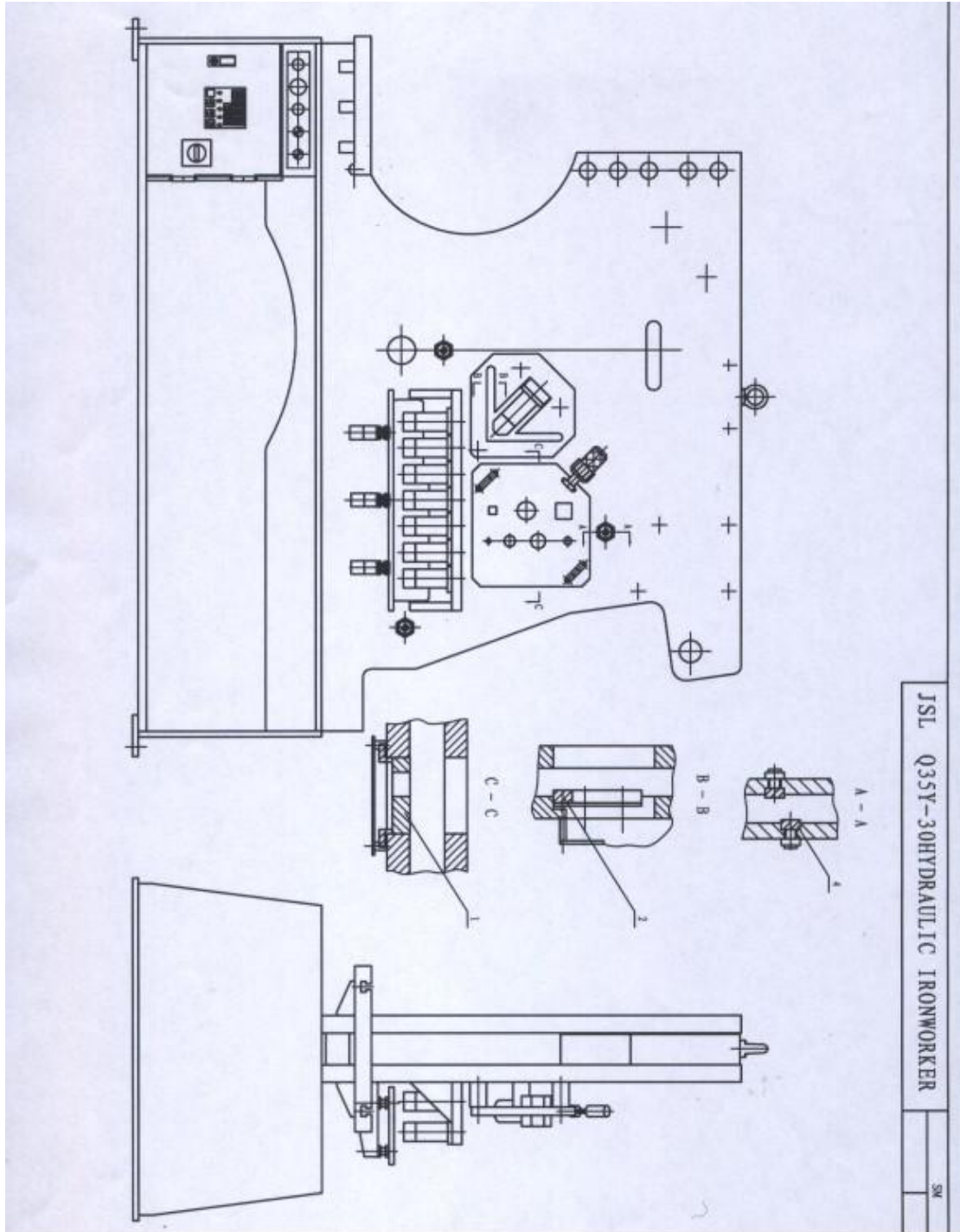

Fig.1

Q35Y-20 H.S.W	SM	
	Total 30 pages	Page 7

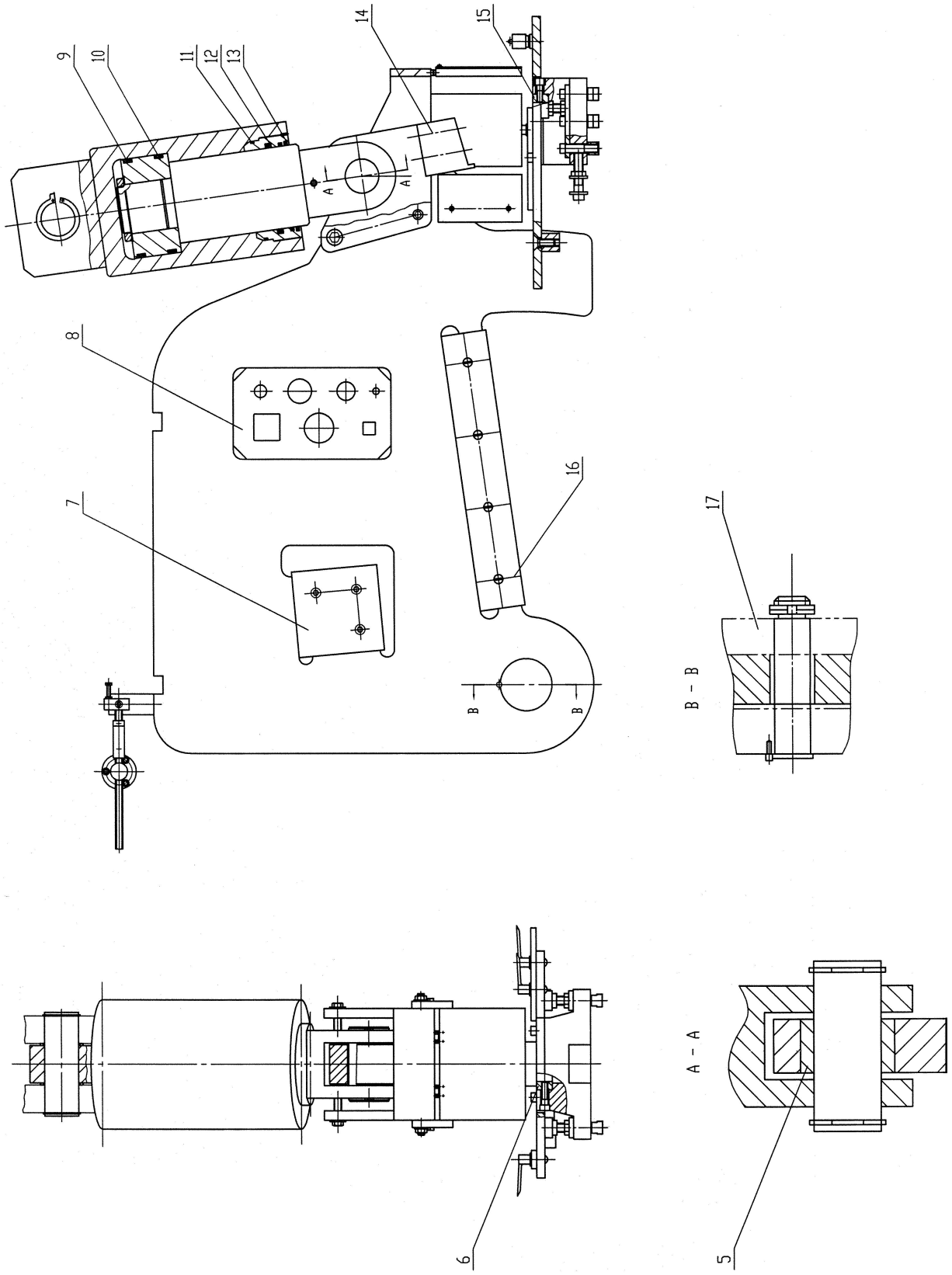

Fig. 2

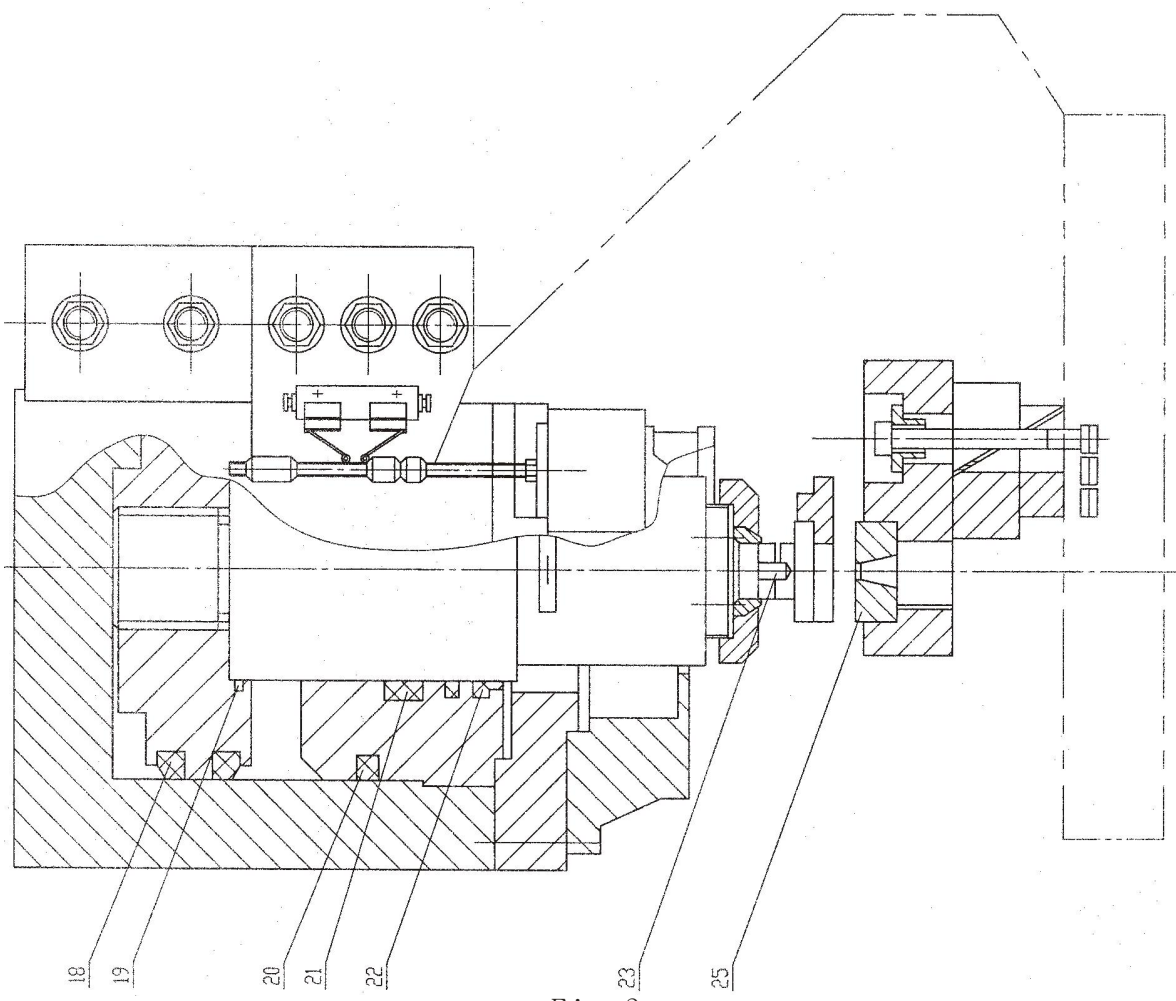
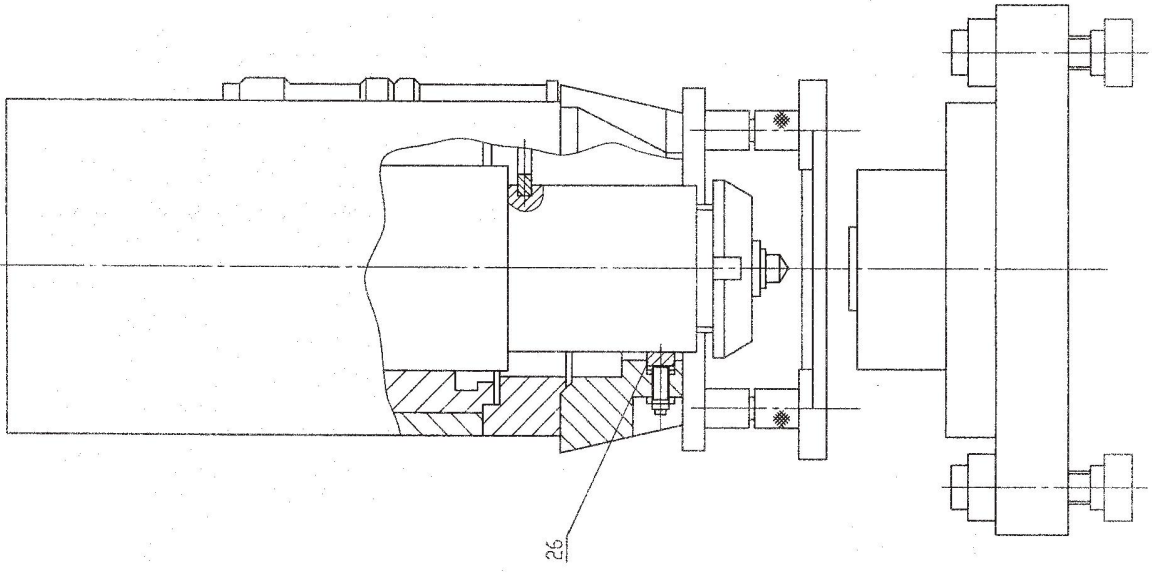

Fig. 3

Q35Y-20 H.S.W	SM	
	Total 30 pages	Page 9

## Six、 Hydraulic System

1,After starting motor(1), the pump(2)should drive oil back to storage tank via electromagnetic overflow valve(4)so as to make itself on unloading in system should flow back to storage tank via overflow valve as soon status.

2, There are three standard knob position, INCHING, SINGLE, RUN.

(1) When move the knob to the INCHING position,stepping the foot pedal, the electromagnet YV5a electrified, and hydraulic oil entered the punching tanks cavity by three or four solenoid valve(3),the punch slows down running downwards(called light-press inching).When loosing foot pedal, the valve(3)in the middle, punching stops at any position, when SINGLE action,stepping foot pedal,YV5a electrified, and hydraulic oil entered the punching tanks cavity by three-position four-ways solenoid valve(3),the punch running downwards at full pressure speed, pressing the rigid switches,YV5b electrified.YV5a power-broken, hydraulic oil goes into the nether tank, punch returns, pressing the rigid switches, toping at the initial position, and the same, when operating profile shear foot pedal board,YV7a electrified, and the oil entered profile shear on the fuel tank cavity by three-position four-ways solenoid electromagnetic valve, profile slow shear plate blade light downward at a SINGLE action,stepping shear-foot pedal, by three-position four-ways solenoid electromagnetic valve into the type of shear on the fuel tank cavity, profile blades board rapidly downward to touch a rigid itinerary point of the switch,YV7b electrified,YV7a power-outages, profile blades board rapidly return, pressing the rigid switches below, profile blade plate stop at the original position.

(2) When the work to standardize continuous rotary position, foot pedal operation,YV5a electrified, and the oil entered the cavity on the fuel tank, running down and test a rigid itinerary switching point,YV5a power-outages,YV5b electrified, and oil tanks into the next cavity, punching rapidly return, pressing the rigid switches below, then moves ahead again norms, when needs stop, stop by the continuous button punch stopped in the position, the same token, profile shear front row with the same.

(3) The highest working pressure is 250 kgf/cm<sup>2</sup> (24.5Mpa) in hydraulic system, the pressure of overflow valve should be adjusted to 25 Mpa, oil as working pressure is overload.



Q35Y-20 H.S.W	SM	
	Total 30 pages	Page 11

## Seven、 Eclectic System

1. Main circuit electrical system of DIW series hydraulic punching shear machine should use three-phase 220-600V, 50-60Hz, and control loops should adopt AC24V and DC24V, which can be obtained through transformer. All the control appliances are installed in a special electrical box, which can keep away from dust or chore .Operational devices such as buttons are installed in operating panel, which will be fixed in box up and have a view.

In accordance with requirement of workmanship, electrical system should be designed as follows:

- a, SA4 screw switch used to obtain single-stroke and point moving norms.
- b, Vertical stroke of punch is controlled by proximity switch SQ1 and SQ2, the section cutting upward and downward movement is separately controlled by the SQ3 and SQ4.
- c, Power supply and oil pump running indicate HL1 and HL2.

### 2.Motor start and stop

The pump motor started button is SB3 and stopped button is SB1or S2, the short circuit and overload of the oil pump motor is protected by the disabled motor switch.

### 3. Procedures

#### 1, single-operation

The machinery in the work regulations should rotate switch SA4 tied to a single location foot pedal, when press the foot pedal switch SA6 or SA7, KA2 or KA4 electrified,YV5b,YV8 or YV7b,YV8 gains the power at the same time, at this time punching shear modulus pistons or the next stroke, when touches the stroke switch SQ2 or SQ4,KA2 or KA4, loses the power, while YV5b,YV8 or YV7b,YV8 power outages, two pistons happen to stop downlink, when fully unclenched the foot pedal SA6 or SA7,KA1 or KA3 obtains electricity, also YV7a or YV5a obtains electricity, the two pistons begin to move. Backhaul will end when touches the two pistons return stroke SQ1 or SQ3.

Q35Y-20 H.S.W	SM	
	Total 30 pages	Page 12

2, inching adjustment

The machinery in the work regulations should rotate switch SA4 to the inching movement location, when press the foot pedal switch SA6,SA7,KA2 or KA4 obtains electricity,YV5b,YV8 or YV5b,YV8 gains the power at the same time, punch piston or the piston of shearing modulus slows downlink, in this process, can loose the foot pedal at random, the piston will stop at this position, the piston will downlink when step the foot pedal. when touches the stroke switch SQ2 or SQ4,KA2 or KA4 loses the power, while YV5b,YV8 or YV7b,YV8 power outages, two pistons happen to stop downlink, when fully unclinched SA6 or SA7,the two pistons can t go up. If return, should rotate SA4 change-over switch to the single position.

### List (I)

Place Touch Point	Locking	Single	Continuous
	30°	0°	30°
1	+		+
2		+	+
3		+	
4		+	+
5	+		
6	+		
7			+
8	+		+
9		+	+
10		+	
11		+	+
12	+		
13	+		
14			+
15	+		

Q35Y-20 H.S.W	SM	
	Total 30 pages	Page 14

List of Electricity Equipment

Symbol	Name	Type	Technical Data	Qty
SB1	Emergency Stop Button	ZB2-102C	Red Mushroom Head	2
SB3	Start Button	ZB2-BWB31C	Green	1
SA4	Key Switch	ZB2-BZ101C	Black	1
SA3	Change-Over Switch	ZB2-BD2C	Black	1
SQ1-4	Overtravel-Limit Switch	TL-N7MD2		4
QF	Disabled Motor Switch	GV2-ME22C	20-25A	1
QS	Load Switch		V1	1
KM1-KM3	AC contactor	LC1-D2510	24V	1
FU1-FU4	Miniature Breaker	C65N	6A	4
HL2	Power Light	XB2-BVB3LC	24V Green	1
VC	Commute Bridge Stack	KPBC35-10	35A	1
D1-D8	Overcurrent Suppressor	3TX3-21A02		1
TC	Transformer	JBK5-250	250VA/29V,24V	1
SA6-SA7	Foot Pedal	MDB		2
KA1-4	Midget Relay	RXM4L	24V 5A	4
KT1-KT2	Time Relay	LH3Y-2	24V	3
	Auxiliary Contact	LADN11		3

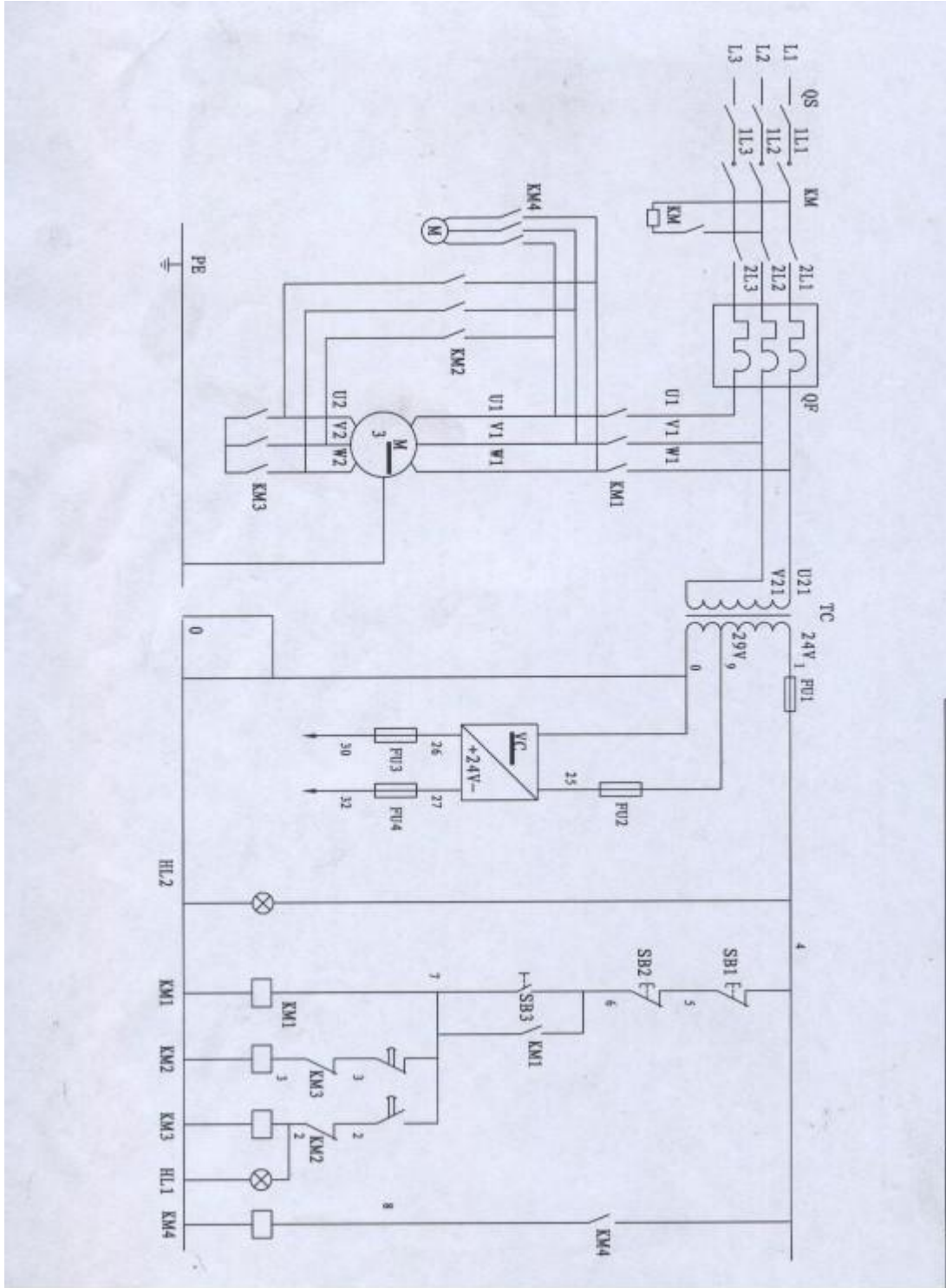

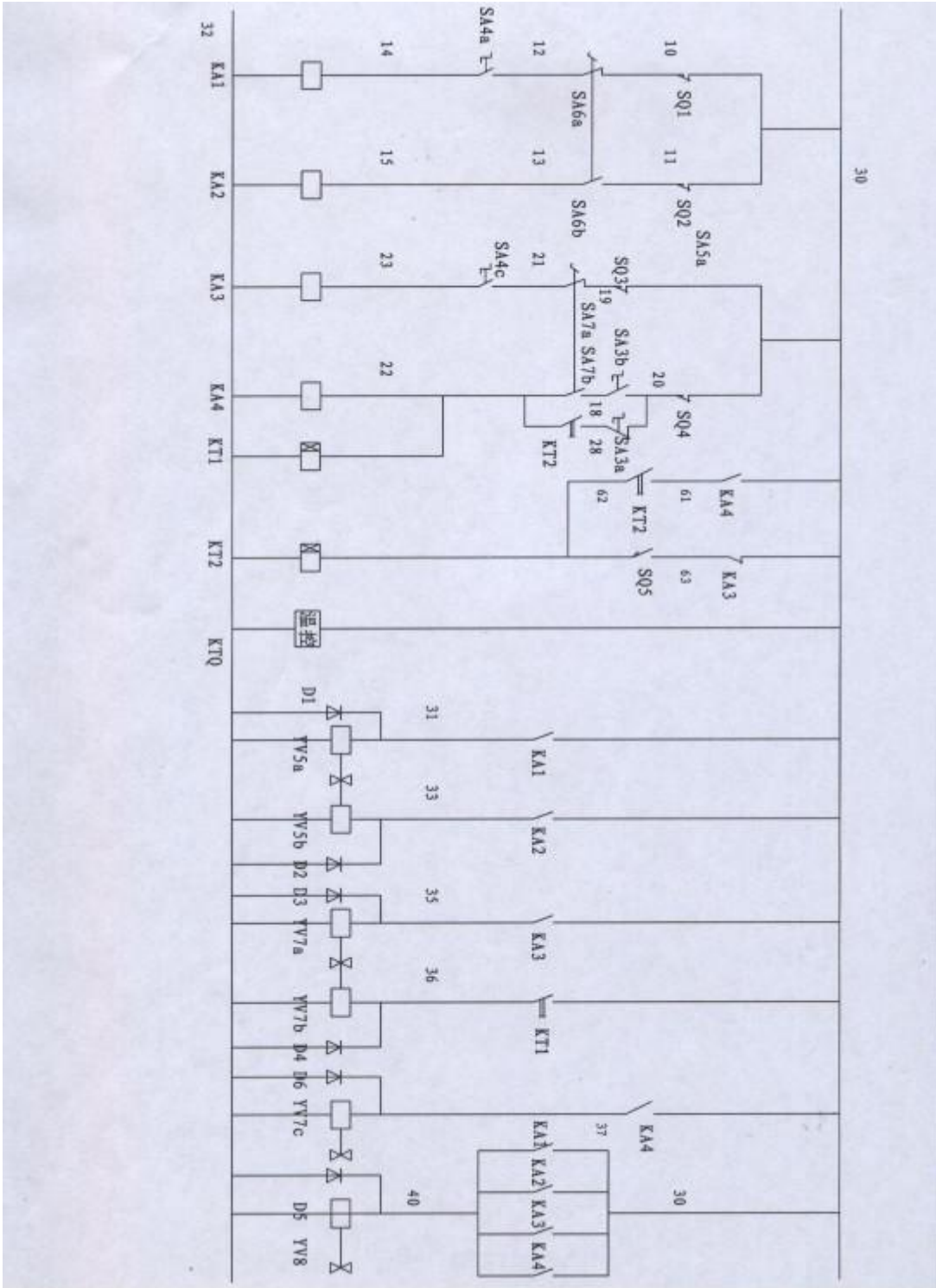

Q35Y-20 H.S.W	SM	
	Total 30 pages	Page 17

## Eight、 Hoisting, Installation & Preparation before Trial Running

### 1, Hoisting

The machine starting with the top of the rings, lifting and escort to use strong chains or cables hanging in the department, after hoisting machine lifts over, this can dismantle the rings, and can not sling chains under the machine for lifting below.

### 2, Installation

The installation of the machines see(Figure 7)

Lay a good foundation before installation, leaving screw hole until solidification of concrete, machines will be placed on the ground, and then using standard correction machines horizontal position, wearing bolts, fluid infusion sand to cement the bottom of the body and screw hole, waiting for drying and then the level table of the punching machines are part of the horizontal position of workstations (100:0.20) Finally fastening bolts.

### 3, Preparation before Trial Running

Scrub mold clean machinery and blade of antirust oil, check whether the various parts defect. All lubrication points for lubricating power lines and check whether the earth intact.

Q35Y-20 H.S.W	SM	
	Total 30 pages	Page 18

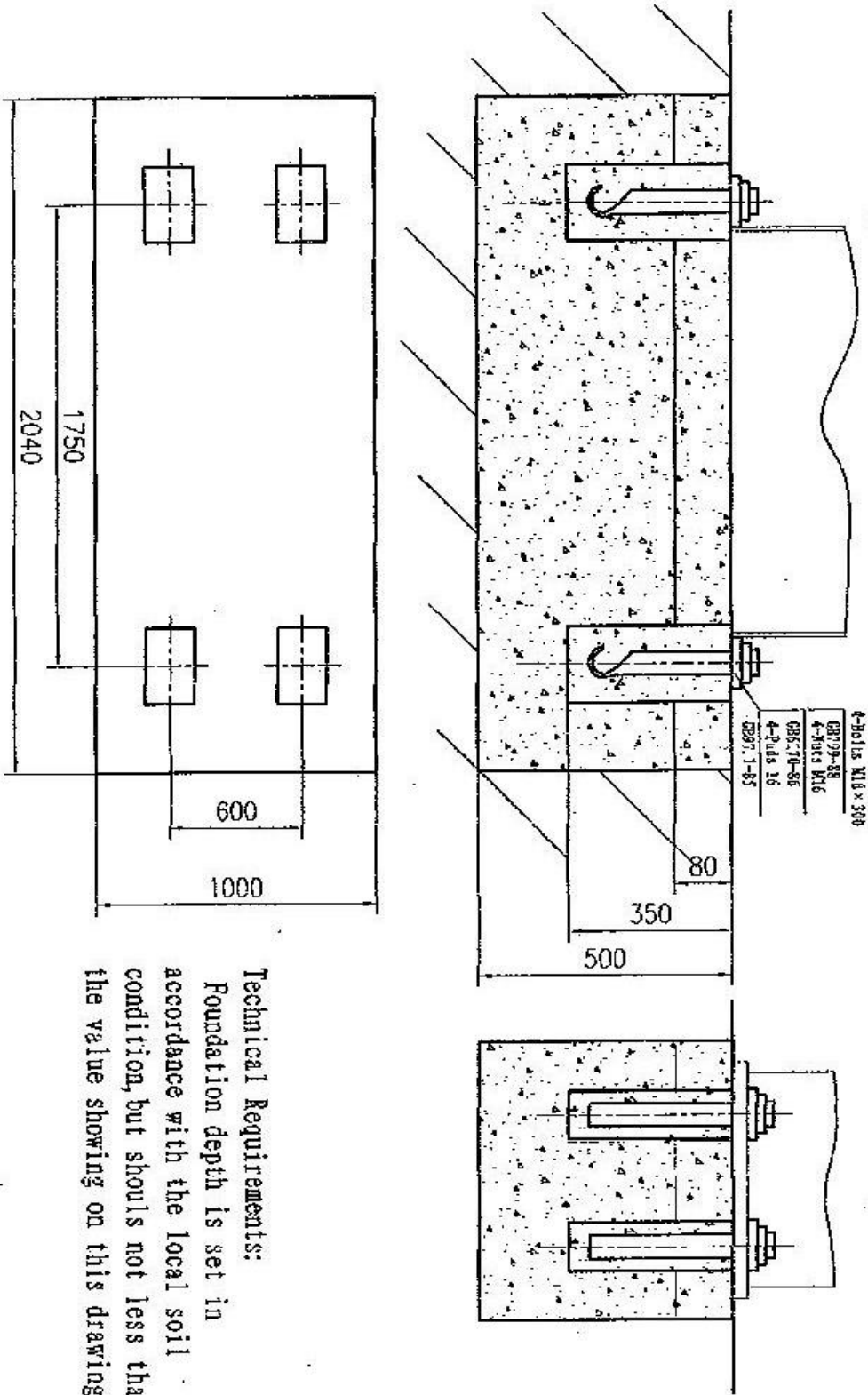

Technical Requirements:  
 Foundation depth is set in accordance with the local soil condition, but should not less than the value showing on this drawing.

Q35Y-20 H.S.W	SM	
	Total 30 pages	Page 19

Nine、Lubricating System

The machines used manual lubrication oil guns, guns within the oil pumping calcium Grease ZG-3,2-3 times each refueling, to guarantee that all lubrication points with adequate fuel.

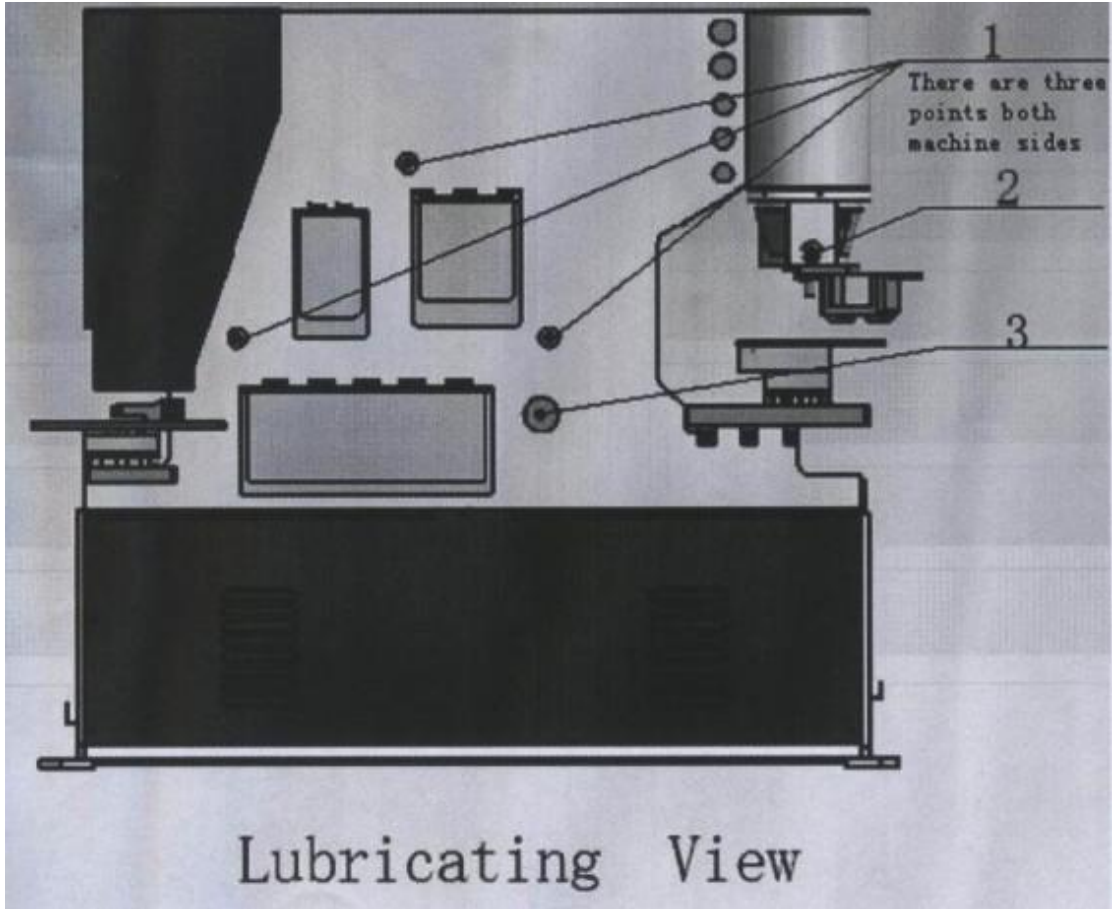

Q35Y-20 H.S.W	SM	
	Total 30 pages	Page 20

## Ten、 Adjustment

### 1, Punching

#### (A) Punching itinerary adjustments see (Figure 3)

There are stop blocks of upper and lower limit switch, which can be vertically adjusted. On the right side of the punching station. According to the required position. The block is fixed on the guide rod. Which is mounted on the piston rod and can be moved with it by set screw.

#### (2) Punch and die under the calibration

Loosen the set screw of the die bolster and turn the knob to the "INCHING" position to make the piston rod in the punching cylinder move downward by inchmeal and the punch align itself with the die, ensure well-distributed around clearance between them. Then fix the bolster on the working table by the set screw and make the punch return to the dead point, so the adjustment before punching operation is finished. There are two holes for mounting dies on the thin plate, other one is used for mounting the die to punch large hole on the thin plate, other one is used for mounting the die to punch hole with diameter less than 30mm and for punching hole on the flange of the channel and angle bar.

#### (3) Adjustment of hold-down board

Binder board must correctly adjusted to Add and Remove the workpiece, the general should be adjusted binder surface of the plate into the next top model for punching distance of 1.2 times the thickness, adjust the pressure plate material, only tighten its link on the right brought the L6k Knurly Nut can.

#### (4) Replacement of the punch and die

Piercing the swap hooked the first wrench is lose locking nut can be removed punch, and put on a new punch and then tighten the nut (various sizes Punch, the installation of its tail is the same size) Therefore swap most economical and convenient.

### 2, cutting flat bar

Both sheet shear, profile shear or shear modulus, the first is the gap adjustment to blades board gap, such as (1) in bed on the right wall, with six pan (4), the pan adjustment screw the nut would ensure that blade in the left wall plate and pan to fit between the clearance for sliding.

#### (1) Blade gap adjustment

Get rid of workstations, blade set in the fastening bolts around, with support for large blade surface of the blade adjustment screw, adjusting These screws, and can set blade knife blade plate moving the gap between adjusted. Adjustments to ensure that the

Q35Y-20 H.S.W	SM	
	Total 30 pages	Page 21

fixed blade parallel to the plane of the blade with a knife blade plate moving the blade surface, so the gap between them evenly, the gap was cut to the general thickness of 10%,the adjustment has been completed, installed workstations.

(2) Replacement of the blade

The upper and lower blade has four bladed scissors, swap four times, or to re-sharpening blades with new replacement blades, the re-adjusted to the attention of the blade gap.

3, the shear angle

(1) Blade adjustment between gap

Relieved angle stent, static blade into by the two right-angled blade components installed. In their fastening bolts around with the support for large blade surface of the blade adjustment screw, screw these adjustments will enable the static blade and carriage moving blade gap between the adjusted. Adjustments to guarantee static blade surface of the blade parallel to the turret on the moving blades of the blade surface, so the gap between them evenly, the gap was generally shear angle steel side of the average thickness of 10% adjusted well after stent installed angle.

(2) Replacement of the blade

The level of static blade razor blades and blade has four vertical bladed. Using dynamic blade screw fixation in the turret, using blunt again after grinding or new ones to replace stationary or static blades, the blade gap should be re-adjusted.

4, bar, square steel shear

(1) Gap adjustment

Relieved steel stent, in the eyes static knife with two sides " " shaped ,screw fastening their use in wallboard, the fastening screws around with adjusting screw for the ultimate realization of a static blade and installed in the turret on the dynamic between the blade gap which is 0.6-0.9,and put on steel stent.

(2) Replacement of the blade

Relieved stent, loosened " " block-shaped iron, out of the old blade, the new ones, the replacement has been completed to be re-adjusted Its space.

5, Notching

(1) Adjustment of blade gap

Dies under the blade on the top side of the entire movement under the block mode, and to ensure the installation of the turret on the top side parallel, and to maintain a reasonable gap, and then use the screw fastening seat in the next die table. Block

Q35Y-20 H.S.W	SM	
	Total 30 pages	Page 22

mode under both sides of the blade gap adjustment, on adjusting their fastening bolts around for the great support they screw the blade surface, and their relative positioning on both sides of the flank should be parallel and maintain a reasonable gap(the thickness were cut 10%)after adjustment, the shear modulus installed workstations.

#### (2) Replacement of the blade

Under the model's three blades, the blade has four edges, swap four times need to re-knife grinding or new ones, cut down with moving-bladed fixed in the turret, loose bolts out of the old and new ones, as long as the replacement, it is important to re-adjust the gap

### Eleven、 Trial Running & Operation

#### 1, Trial Running & Preparation before Operation

- (1) Fill the irrigation tank full filtered L-HM46 General hydraulic oil 200kg (user-owned)
- (2) Inspect the blade gap whether it is appropriate, if necessary, making adjustments.
- (3) Turn on the power supply and check if actions of various electrical elements are correct, installation is appropriate. The buttons were pressed, the stroke switch, foot pedal and so on to observe if actions is sensitive.
- (4) Start motor and watched if its running direction is correct, check hydraulic pressure within the system whether it meets the requirements, the overflow pressure relief valve compliance, whether to move sensitive valve.

#### 2, Trial Running & Operation

When former test preparatory work has been completed and proceed with testing operations, procedures are as follows:

- (1) Pushing the operating button connected to the power switch, the Green Lights-specified electrical power system can operate.
- (2) Starting the motor, lubricating the top and lower chambers of the punching cylinder and section cutting cylinder in order, check if the punch and section cutting blade can reach the top and lower dead point.
- (3) Operation of the air testing, in order to punch, shear profiles to move for a single stroke and the test must carefully test each part of the normal work, such as failure, we must be ruled out even before continuing down the pilot.
- (4) Load test, the progressive loading, the biggest specifications or punching shear test when the number shall not be less than three times.

Q35Y-20 H.S.W	SM	
	Total 30 pages	Page 23

## Twelve、 Safety & Maintenance

The machines are equipped with protective covers, and shall not put your hands into it, in addition, attention should be paid as follows:

- (1) Users must be familiar with the use of the machinery manuals and have certain technical aspects of the operation.
- (2) It needs good contact for the electrical insulation.
- (3) Punching and shear could not work together
- (4) Don't work overload ( $\leq$ strength 450N/mm<sup>2</sup>,hardness should be  $\leq$ HB180).
- (5) Blade needs to maintain sharp.
- (6) The surface of the sheet plates punched is welded perfect and don't have prominent scar.
- (7) To ensure punch and shear safety, it must be adjusted according to the specifications of different workpiece materials.
- (8) The replacement tool must be re-examined after the blade gap and, if necessary, it needs to adjust timely.
- (9) Periodic inspection of the mechanical needed, and if it is abnormal, it needs to stop and maintain.
- (10) In order to avoid friction surface bite, the point lubrication should oil-filled according to the duration of working.
- (11)After period of machine using, it should adjust the gap between stop running button and piston ring by the screw. Keep the gap at 0.1mm for prevent the turning of the piston ring.
- (12) After period of machine using, due to the damage of the friction block, it should adjust both friction blocks (4) by the screw for keeping a reasonable gap between knife rest and friction blocks.

Q35Y-20 H.S.W	SM	
	Total 30 pages	Page 24

Thirteen、List of Wearing Parts & Outsourcing Parts

One、List of Outsourcing Parts

Serial Number	Code Name	Name	Spec	Material	Qty	Remark
17		S6 seal ring	300×280×15	polyurethane	2	
18	GB1235-76	O-shape seal ring	110×3.1	polyurethane	1	
19	GB1235-76	O-shape seal ring	220×5.7	polyurethane	1	
20		U-shape seal ring	220×200×12.5	polyurethane	2	
21	GB1235-76	O-shape seal ring	195×8.6	polyurethane	1	
22		dustproof ring	180	polyurethane	1	
23	SF-2	axletree	9090		1	
24		dustproof ring	200	polyurethane	1	
25	GB1235-76	O-shape seal ring	215×8.6	polyurethane	1	
26		U-shape seal ring	225×200×16	polyurethane	1	
27	GB1235-76	O-shape seal ring	300×5.7	polyurethane	1	
28		U-shape seal ring	200×180×12.5	polyurethane	1	
29	GB1235-76	O-shape seal ring	140×3.1	polyurethane	1	

Q35Y-20 H.S.W	SM	
	Total 30 pages	Page 25

Thirteen、 List of Wearing Parts & Outsourcing Parts

One、 List of Outsourcing Parts

Serial Number	Code Name	Name	Spec	Material	Qty	Remark
17		YX-shape seal ring	D=220	polyurethane	2	
18	GB1235-76	O-shape seal ring	110×3.1	polyurethane	1	
19	GB1235-76	O-shape seal ring	220×5.7	polyurethane	1	
20		YX-shape seal ring	D=220	polyurethane	2	
21	GB1235-76	O-shape seal ring	195×8.6	polyurethane	1	
22		dustproof ring	180	polyurethane	1	
23	SF-2	axletree	9090		1	
24		dustproof ring	200	polyurethane	1	
25	GB1235-76	O-shape seal ring	215×8.6	polyurethane	1	
26		YX-shape seal ring	D=200	polyurethane	1	
27	GB1235-76	O-shape seal ring	270×5.7	polyurethane	1	
28		YX-shape seal ring	D=180	polyurethane	2	
29	GB1235-76	O-shape seal ring	140×3.1	polyurethane	1	

Q35Y-20 H.S.W	SM	
	Total 30 pages	Page 26

Thirteen、 List of Wearing Parts & Outsourcing Parts

One、 List of Outsourcing Parts

Serial Number	Code Name	Name	Spec	Material	Qty	Remark
17		S6 seal ring	270×250×14	polyurethane	2	
18	GB1235-76	O-shape seal ring	110×3.1	polyurethane	1	
19	GB1235-76	O-shape seal ring	220×5.7	polyurethane	1	
20		U-shape seal ring	220×200×12.5	polyurethane	2	
21	GB1235-76	O-shape seal ring	195×8.6	polyurethane	1	
22		dustproof ring	180	polyurethane	1	
23	SF-2	axletree	9090		1	
24		dustproof ring	200	polyurethane	1	
25	GB1235-76	O-shape seal ring	215×8.6	polyurethane	1	
26		U-shape seal ring	225×200×16	polyurethane	1	
27	GB1235-76	O-shape seal ring	270×5.7	polyurethane	1	
28		U-shape seal ring	200×180×12.5	polyurethane	1	
29	GB1235-76	O-shape seal ring	140×3.1	polyurethane	1	

Q35Y-20 H.S.W	SM	
	Total 30 pages	Page 27

Thirteen、 List of Wearing Parts & Outsourcing Parts

One、 List of Outsourcing Parts

Serial Number	Code Name	Name	Spec	Qty
4	Friction Block	ZZnAL-6	6	0.9
17	Axletree	ZQAL11-6-6	1	1.8
26	Stop Running Button	Ht90	1	1

Fourteen、 List of Accessories Furnished

Name	Spec	Qty	Remark
Socket Screw Hexagon Wrench	S=3-16	1	
Claw Wrench	D=90-95	1	
Channel Steel Shear			Special Order
I-Beam Shear			Special Order
Large Punch Dies			Special Order
I-Beam/ Channel Steel Punch Dies			Special Order
Bending Dies			Special Order
Canulation Shear			Special Order
Punch Shutter			Special Order
Foot Pedal			Special Order

Q35Y-20 H.S.W	SM	
	Total 30 pages	Page 28

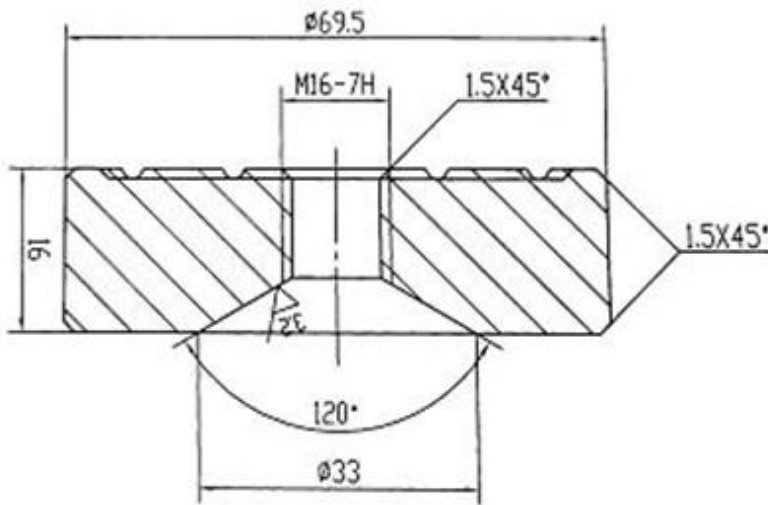
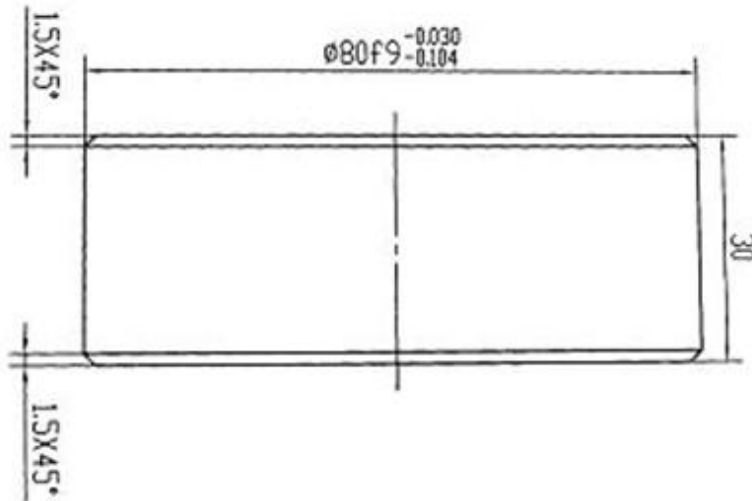

4	Friction block	ZZnAL-6	6	1.3	1:1
NO.	Name	Material	Qty	Weight	Remark

Q35Y-20 H.S.W	SM	
	Total 30 pages	Page 29

Φ10HP	+0.087 Φ100 0
Φ115kb	+0.025 Φ115 +0.003

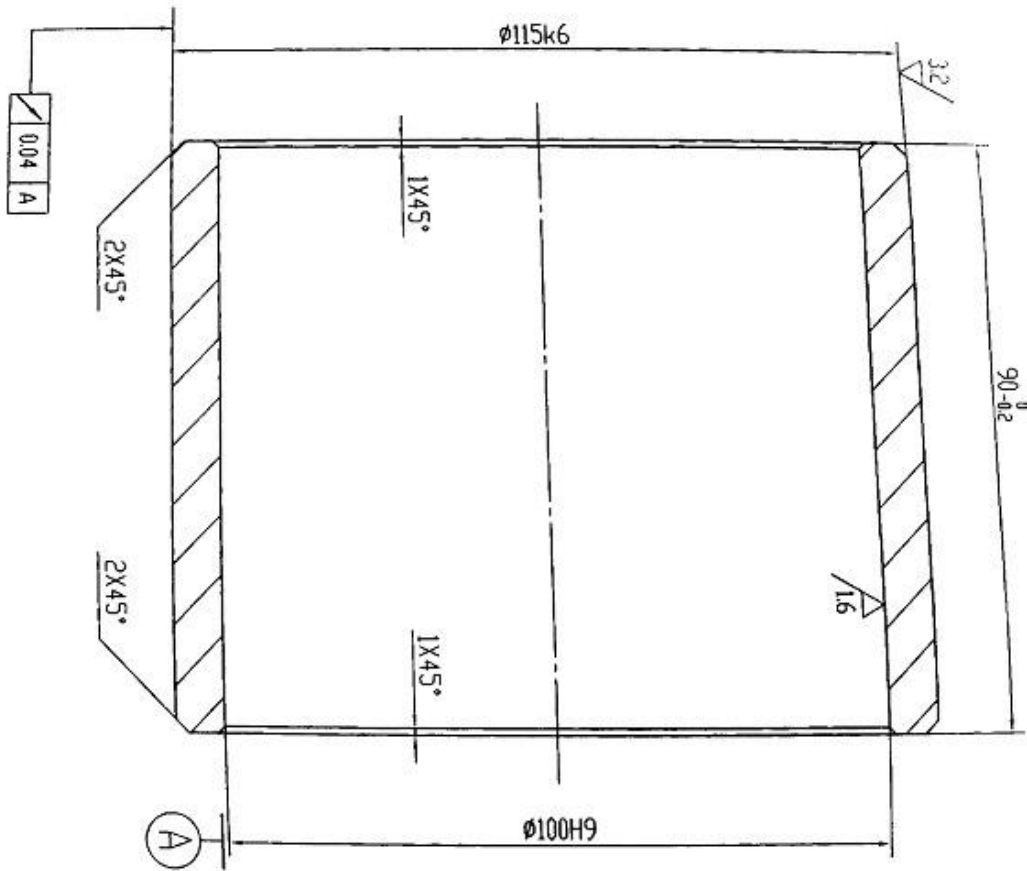

17	Axletree	ZZnAL11-6-6	1	1.8	1:1
NO.	Name	Material	Qty	Weight	Remark

Q35Y-20 H.S.W	SM	
	Total 30 pages	Page 30

Other 125/

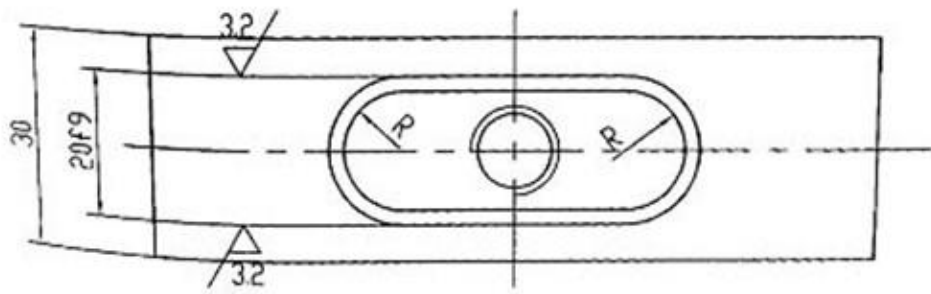
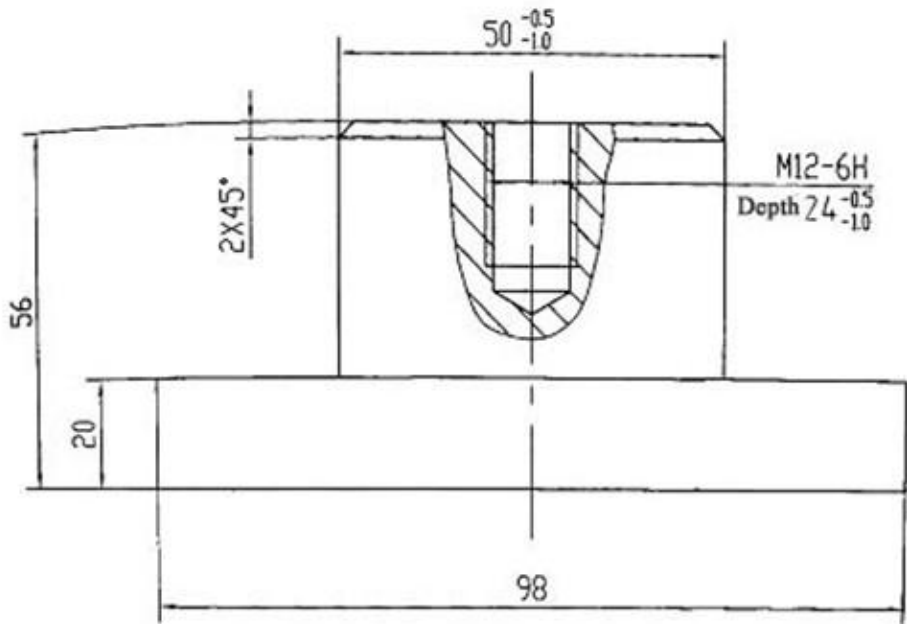

26	Stop running button	Ht200	1	0.7	1:1
NO.	Name	Material	Qty	Weight	Remark