

Contents

I、TYFB-4200 Turbo Molecular Pump

1. Introduction	3
1.1 Overview	3
1.2 Structural Features	3
2. Technical Specifications	4
2.1 Technical Parameters	4
2.2 Installation Dimensions	5
3. Regarding Ultimate Pressure (Ultimate Vacuum)	7
4. Installation and Usage	7
4.1 Installation	7
4.2 Lubrication Oil Injection	7
4.3 High Vacuum Flanges Connection	7
4.4 Fore-vacuum Connection	8
4.5 Vent Connection	8
4.6 Cooling	8
4.7 Molecular Pump's Baking	8
4.8 Usage	8
5. Examples of Molecular Pump Applications in Vacuum Air Paths	9
6. Maintenance	10
6.1 Cleaning	10
6.2 Replacement of bearings	10
6.3 Impact Protection	10
6.4 Vibration Isolation	10
6.5 Strong Magnetic Field Shielding	10
6.6 Electromagnetic Interference	10
6.7 Strong Radioactivity Limitations	10
6.8 Fore-Vacuum Pump	10

II. B-4200 Molecular Pump Power Supply

1. Parameters and Functions	11
1.1 Overview	11
1.2 Installation Dimensions	11
1.3 Electrical Parameters	11
1.4 Front Panel Button and Interface Functions	12
1.5 Rear Panel Interface Functions	13
2. Conventional Assembly and Power-on Testing	15
2.1 Power Distribution of the Entire Machine and Precautions	15
2.2 Application of Remote Control Interface	15

III. Conventional Operation Procedure Based on B-Type Power Supply

1. Conventional Operation Procedure Table	16
2. Explanation of the Meaning of Digital Display Screen Headers	17
3. Alarm Code Comparison Table and Solutions	17

IV. Common Faults and Troubleshooting

1. Common Faults and Troubleshooting Table	18
---	-----------

V. Inventory and Unboxing

1. Inventory	18
2. Unboxing	18
Warranty Information	19
Warranty form	20

I、 TYFB-4200 Turbo Molecular Pump

1. Introduction

1.1 Overview

The TYFB-4200 Turbo Molecular Pump is a mechanical vacuum pump that achieves suction through the relative high-speed rotation of multi-stage dynamic and static turbine blades. This turbo molecular pump has the features of high pumping speed and a high compression ratio in the molecular flow region. It is more energy-efficient and less prone to oil vapor pollution compared to diffusion pumps. The TYFB-4200 Turbo Molecular Pump currently has the highest pumping speed among domestic molecular pumps. Its dynamic impeller is processed with variable cross-section, resulting in high-strength, lightweight, and more reliable and stable pump performance.

This molecular pump has no selectivity or memory effect on the pumped gas. It can achieve clean high vacuum and ultra-high vacuum without the need for cold traps and oil baffles as a result of its high compression ratio for gases with a large molecular weight. It is widely used in different fields of electronics, metallurgy, chemical industry, scientific research, and vacuum technology.

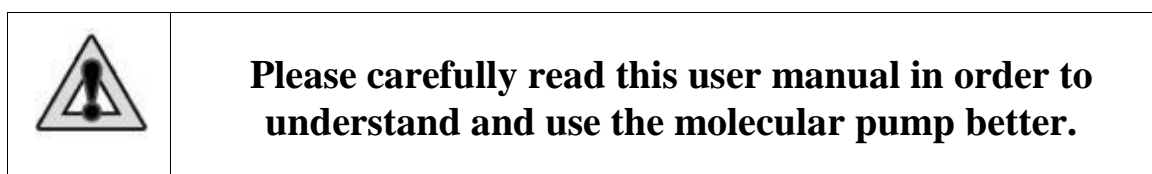

1.2 Structural Features

The TYFB-4200 Turbo Molecular Pump is supported by imported precision ceramic bearings. It is water-cooled with a cooling water temperature of 10°C to 22°C. The pump rotor undergoes dynamic balancing, ensuring smooth and reliable operation. It is equipped with a squirrel-cage, three-phase motor. In addition, bearing lubrication is achieved through self-priming oil lubrication with a tapered hole shaft, which is simple and reliable. However, this design requires the molecular pump to be installed vertically.

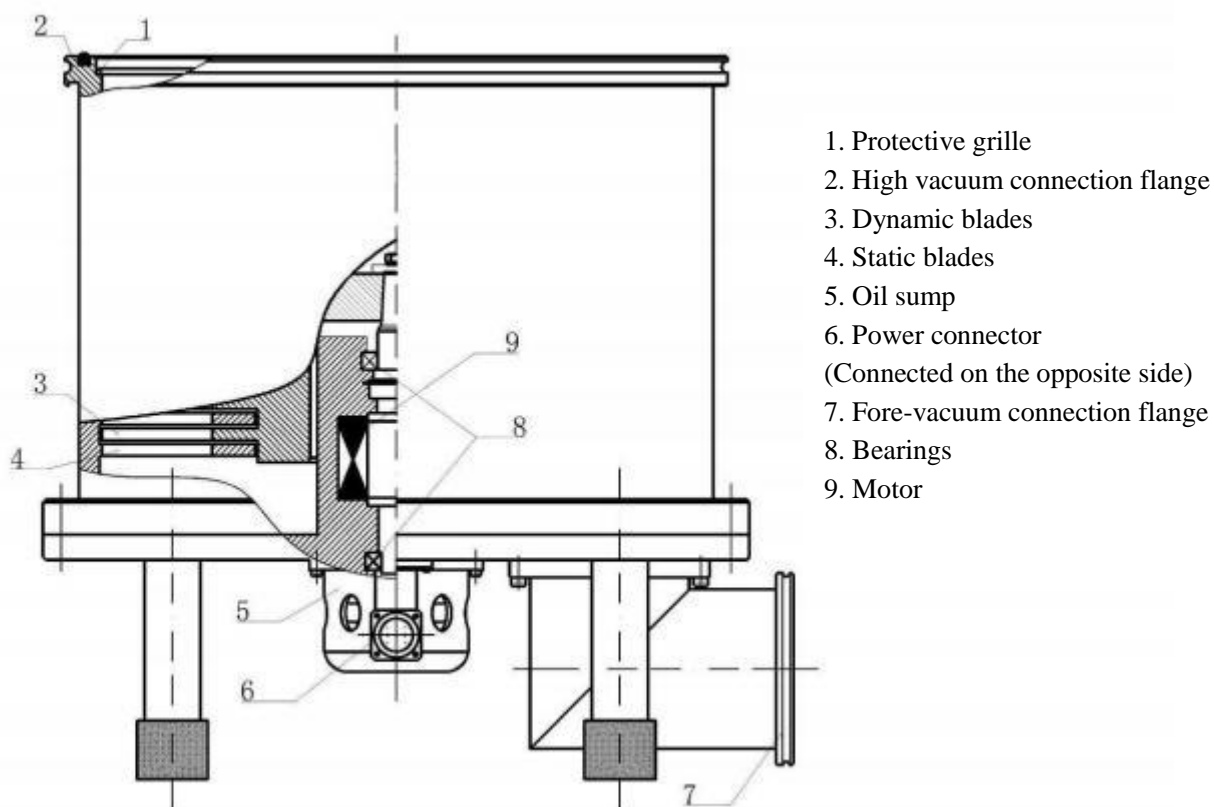

Image 1: Schematic Diagram of the TYFB-4200 Turbo Molecular Pump Structure

2. Technical Specifications

2.1 Technical Parameters

The TYFB-4200 Turbo Molecular Pump Structure Diagram is shown in Figure 1. Technical data can be found in Table 1. The pumping speed curve is shown in Figure 2. Compression ratios for nitrogen and hydrogen are illustrated in Figure 3.

Table 1: Technical Parameters of the TYFB-4200 Turbo Molecular Pump		
Model Number	TYFB-4200	
High Vacuum Flange	400 ISO-K	
Fore-Vacuum Pipeline Flange	100 ISO-K	
Pumping Speed (L/s)	4200	
Compression Ratio	N ²	>10 ⁸
	H ²	>8X10 ²
Ultimate Pressure (Pa)	<1×10 ⁻⁶	
Rated Speed (rpm)	15600	
Imported Ceramic Ball Bearings	Vibration Value (μm)	
Vibration Value (μm)	≤0.15	
Startup Time (min)	<12	
Shutdown Time (min)	<16	
Recommended Fore-vacuum Pump (L/s)	30-70	
Oil Capacity (ml)	100	
Cooling Mode:	Water cooling	
Cooling Water Temperature (°C)	10-22	
Cooling Water Flow Rate (L/min)	2	
Pump Body Baking Temperature (°C)	<120	
Ambient Temperature (°C)	5-40	
Mounting Direction	Vertical ±5°	
Pump Weight (kg)	≈122KG	

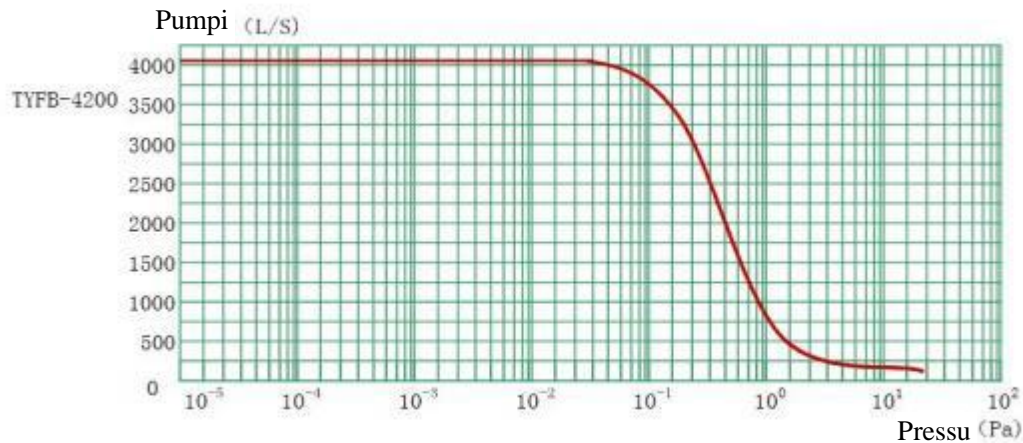

Figure 2: The TYFB-4200 Turbo Molecular Pump Pumping Speed Curve

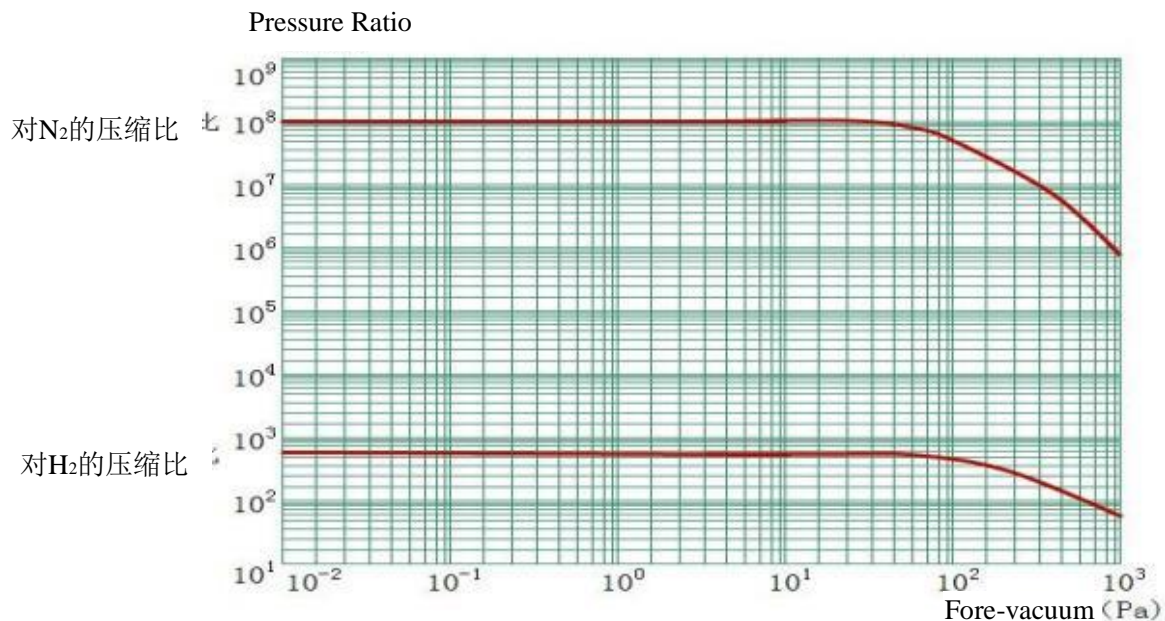

Figure 3: Compression Ratio Curves for Nitrogen and Hydrogen by the TYFB-4200 Turbo Molecular Pump

2.2 Installation Dimensions

The TYFB-4200 Turbo Molecular Pump High Vacuum Connection Flange 400 ISO-K size can be found in Figure 4. On the other hand, the Fore-Vacuum Connection Flange 100 ISO-K size can be found in Figure 5. Installation dimensions are indicated in Figure 6.

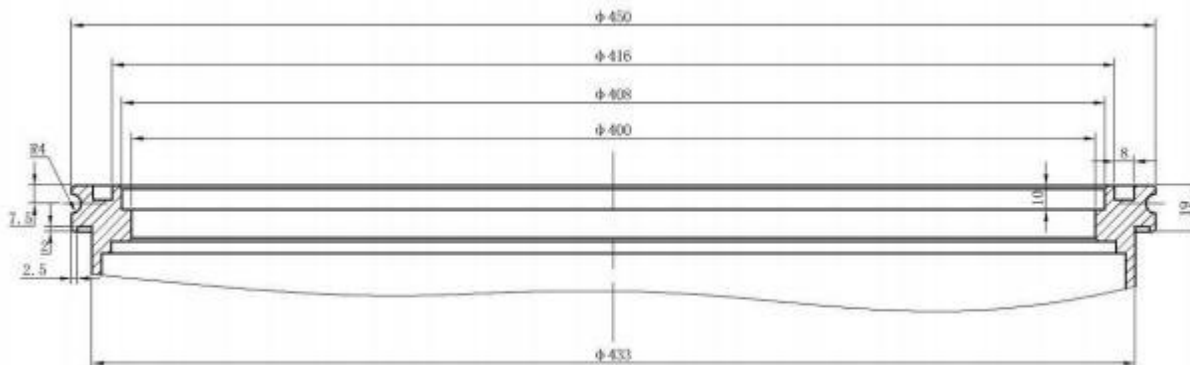

Figure 4: Schematic Diagram of the TYFB-4200 Turbo Molecular Pump High Vacuum Connection Flange (400 ISO-K) Dimensions

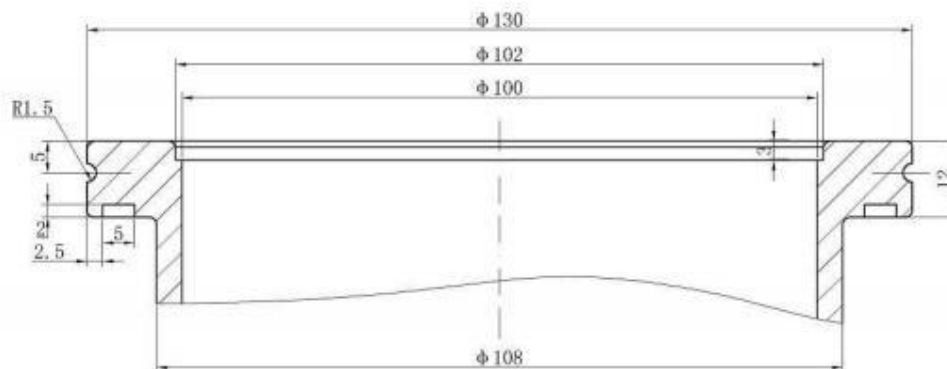

Figure 5: Schematic Diagram of the TYFB-4200 Turbo Molecular Pump Fore-Vacuum Connection Flange (100 ISO-K) Dimensions

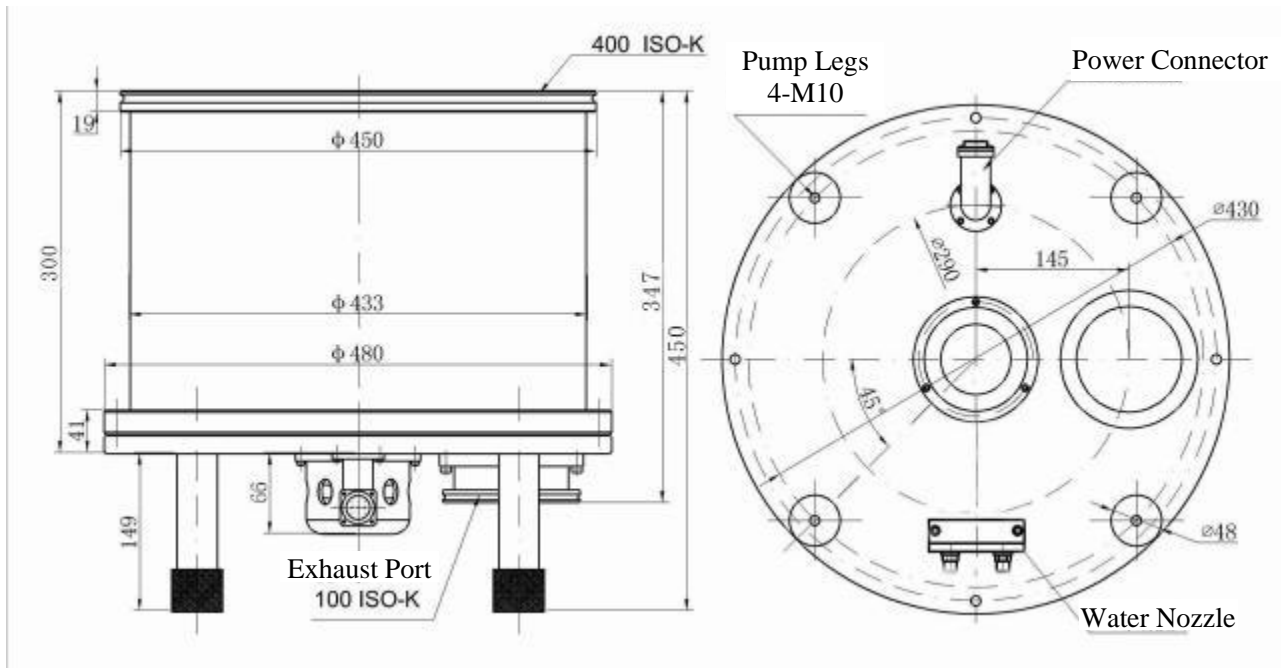
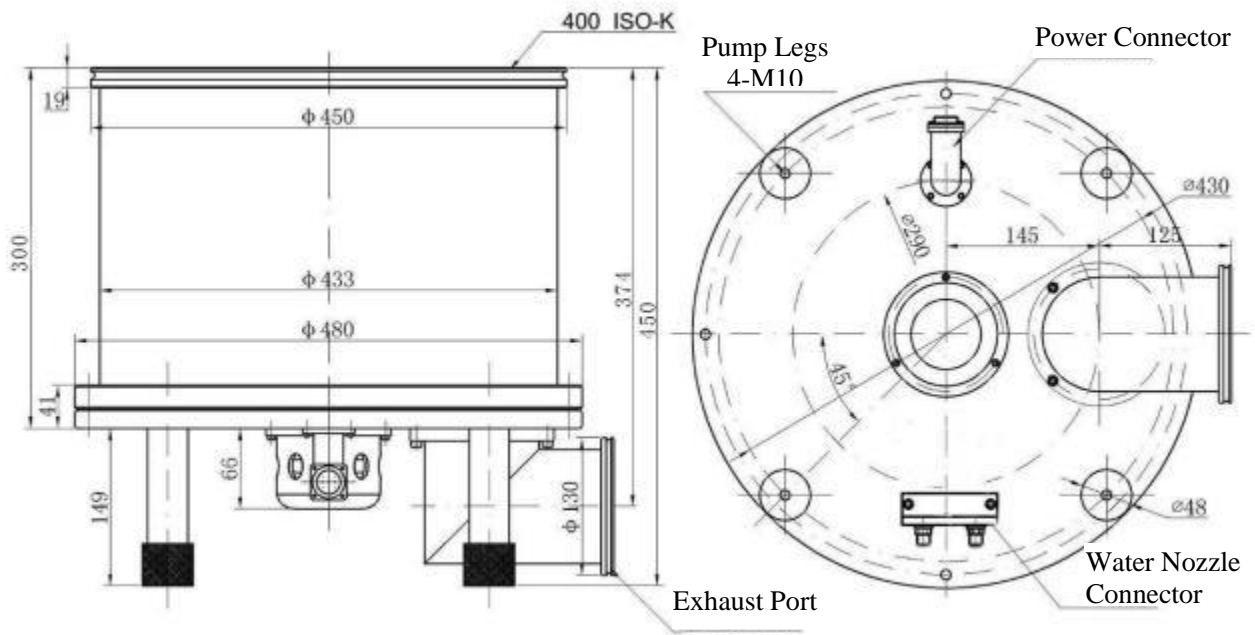

Figure 6: Schematic Diagram of the TYFB-4200 Turbo Molecular Pump Installation Dimensions

3. About Ultimate Pressure (Ultimate Vacuum)

Molecular pump "ultimate pressure" is determined based on the ISO international standard "Performance Test Methods for Turbo Molecular Pumps." It is the lowest pressure value measured at the test chamber's specified location after the pump body and test chamber have been thoroughly baked (48 hours of drying and degassing). In practical use, the "ultimate pressure" value is related to the working pressure and effective pumping speed of the fore-vacuum pump that is installed. Choosing a fore-vacuum pump with higher performance is advantageous for achieving higher vacuum levels and reducing the evacuation time.

In addition, it is recommended that the inlet of the pump be as wide as possible due to the unique exhaust principles of molecular pumps. Furthermore, the gas path from the vacuum chamber to the molecular pump should avoid sharp bends in order to maximize the molecular pump's efficiency and ensure a higher ultimate vacuum.

4. Installation and Usage

4.1 Installation

Inspect the molecular pump for any damage that may have occurred during transport before installation.

The installation process is as follows: Follow the molecular pump power supply instructions, connect it correctly to the molecular pump, do not introduce water, and do not start a vacuum. Start the molecular pump to see if it operates smoothly without any abnormal noises. Press the stop button immediately to shut down the pump if any abnormalities are observed. Note: The power frequency should not exceed 25 Hz during the test run.

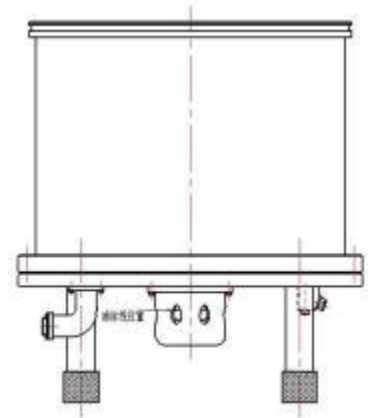

	<p>TY series oil-lubricated turbo molecular pumps must be installed vertically and should not be inclined more than $\pm 5^\circ$.</p>
--	--

4.2 Lubrication Oil Injection

The oil sump is not filled with oil for safety during transport. Lubricating oil is packaged separately in plastic bottles.

The lubricating oil injection procedure is as follows: Use an Allen wrench to loosen the locking screw on the oil sump, remove the oil sump, and inject the specialized molecular pump oil from outside the oil sump through the oil sump filter screen. The oil level should be between the upper and lower oil level marks on the oil sump. Moreover, it should not be below the lower mark. Be careful not to lose the oil sump seal ring when installing the oil sump, and tighten all three locking screws evenly to prevent air leakage.

	<p>It is essential to inject oil first for the first use of the molecular pump! The oil should be changed annually if the molecular pump runs for less than 5000 hours within a year in regular operation. The oil should be changed every 5000 hours if the molecular pump runs for more than 5000 hours within a year! It is necessary to use the manufacturer's provided special molecular pump lubricating oil. Any violation of this instruction will result in self-assumed consequences !</p>
---	---

4.3 High Vacuum Flange Connection

The molecular pump can be connected using a high-vacuum flange suspension or by fixing it to a base. The molecular pump's high-vacuum interface should be placed as close as possible to the vacuum chamber being evacuated.



	<p>The flange sealing surface should not have scratches. There should also be no foreign objects on the sealing ring.</p>
---	--

4.4 Fore-Vacuum Connection

There should be a vent valve installed between the fore-vacuum pump and the molecular pump in order to prevent backflow of oil from the mechanical pump after shutdown.

4.5 Vent Connection

Nitrogen or dry air can be introduced into the vacuum system after the molecular pump is shut down in order to maintain a clean vacuum environment. Generally, a vent valve can be connected to the fore-vacuum pipeline or used at the high vacuum end.

4.6 Cooling

It is necessary to cool the bearings and motor when the molecular pump is operating due to the high-speed rotation friction of the bearings, the heating of the pump body, and the temperature rise of the motor.

The water pipe's outer diameter is 10 mm, and the wall thickness is 1 mm. Soft water pipes of this size can be directly connected to the inlet and outlet of the molecular pump. They can also use a circulating water system with pure water or low-sediment tap water (water temperature: 10°C to 22°C).

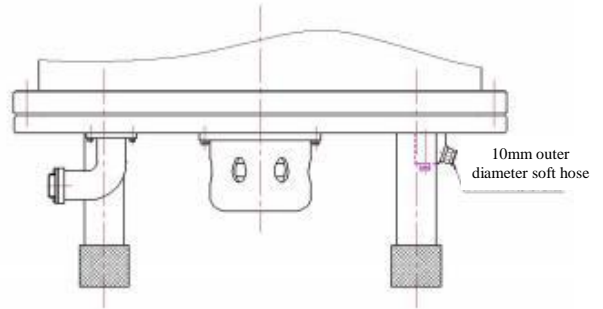

Unexpected water stoppage or very high water temperature can activate the temperature sensor in the molecular pump, which will trigger the power supply to immediately sound an alarm and stop the output.

There is an interval of approximately 15 minutes before the molecular pump sounds an alarm as a result of overheating after an unexpected water stoppage or very high water temperature (the specific time depends on the rate of temperature rise).

4.7 Molecular Pump's Baking

The ultimate pressure is dependent on the cleanliness of the interior of the pump body and the vacuum system, as well as the cleanliness of the vacuum chamber. The vacuum system and the molecular pump must be baked in order to achieve the ultimate pressure in the shortest amount of time.

The molecular pump should be operating normally while baking. Also, be sure to keep the molecular pump's cooling water running.

The baking temperature for the molecular pump should be below 80°C, and the high vacuum flange connected to the pump should not exceed 120°C. Generally, the baking temperature for the vacuum system is below 300°C. Exceeding these baking temperatures can cause damage to the molecular pump components.

The baking time depends on the system's and the molecular pump's degree of contamination, as well as the desired ultimate working pressure. However, it should not be less than 4 hours at a minimum.

Generally, baking is not required to achieve a vacuum of 10^{-4} Pa. Baking the vacuum system itself is sufficient to achieve a vacuum of 10^{-5} Pa.

Unexpected water stoppages or very high water temperatures can activate the temperature sensor in the molecular pump. In addition, the power supply will immediately sound an alarm and stop output. The measuring system should be thoroughly baked, since inadequate baking can affect the accuracy of measurement as a result of outgassing.

4.8 Usage

The details for starting and shutting down the pump can be found in the power supply section of this user manual.



It is strictly prohibited to move, transport, or introduce atmospheric air while the molecular pump is operating normally.

5.Examples of Molecular Pump Applications in Vacuum Air Paths

The design of the exhaust gas path for molecular pumps differs from that of diffusion pumps. Below are some typical examples and explanations of molecular pump air path applications.

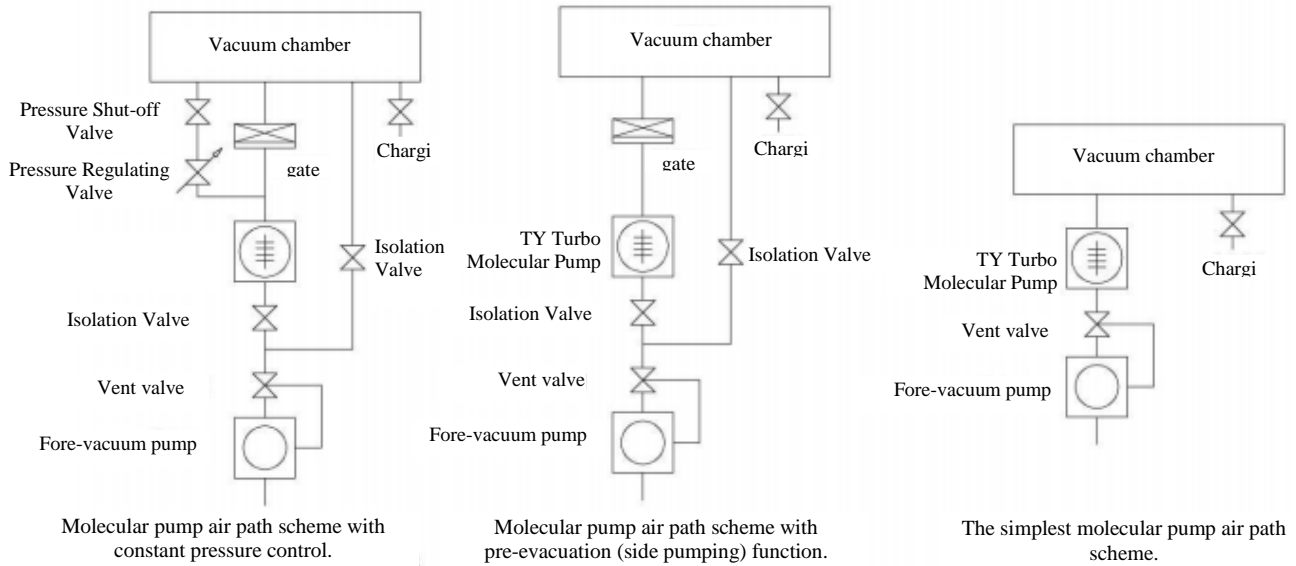

Simple Molecular Pump Air Path Scheme (Right Image)

It is usually used for testing the performance of molecular pumps or other scientific testing equipment. The vacuum chamber's interior and materials remain relatively stable, eliminating the need for frequent vacuum chamber openings during indoor operations. An isolation vent valve should be installed if an oil-based rotary vane mechanical pump is used as the foreline pump. In case of power failure, the isolation vent valve must be connected to the foreline pump to prevent oil vapor or oil liquid from entering the molecular pump. Some rotary vane mechanical pumps come with built-in isolation vent valves to prevent long-term oil contamination and pollution of the foreline.

Molecular pump system with pre-pumping (side-pumping) function (middle diagram).

It is generally used in equipment where the vacuum chamber is frequently opened. It is advisable to avoid repeated starts of the molecular pump during operation. Repeatedly starting the molecular pump not only wastes time but also causes the molecular pump to pass through the resonance region frequently, accelerating wear on the molecular pump. Therefore, you can close the gate valve and both isolation valves when opening the vacuum chamber, then open the inflation valve to restore pressure. Once the pressure is restored, open the vacuum chamber for various applications. At this point, the molecular pump and foreline pump are in normal operation. Start by opening the pre-pumping isolation valve and directly evacuating the vacuum chamber with the foreline pump when evacuating the vacuum chamber again. Close the pre-pumping valve and open the isolation valve and gate valve when the vacuum level reaches the foreline pump's ultimate limit and the molecular pump's safe operating pressure in order to complete the high vacuum re-evacuation process.

Molecular pump system with constant pressure control (left diagram).

It is used in equipment where the vacuum chamber needs to be pressurized and maintained at a certain low pressure. In this case, you can close the gate valve and open the constant-pressure gas supply line, adjusting the control valve to reduce the exhaust speed. The constant pressure shut-off valve helps to avoid frequent opening and closing of control valves. After adjusting the control valve, the shut-off valve usually controls the opening and closing of the constant-pressure gas supply line.

Valve selection and installation considerations: Ordinary vacuum valves have different sealing directions. It is important to identify the sealing direction correctly, since incorrect installation may lead to intermittent leaks or an inability to achieve the desired vacuum level.

- The sealing surface of the gate valve and isolation valve should be on the molecular pump's side. This ensures that the valve will not be forced open by strong pressure differences between the molecular pump and the vacuum chamber during the pre-pumping process.
- The sealing surface of the side-pumping valve should be on the foreline pump's side. This ensures that the side-pumping valve will not be forced open by atmospheric pressure when the vacuum chamber returns to atmospheric pressure.
- The isolation vent valve's sealing surface should be on the side of the isolation valve and pre-pumping valve (with the venting port on the foreline pump's side).

6. Maintenance

6.1 Cleaning

The pump should be cleaned when there is no change in the vacuum system's leak rate and outgassing rate, even after prolonged baking, or when the foreline pump experiences severe oil backflow.



Professional technicians must disassemble and reassemble the pump if it needs cleaning and repair. Unauthorized disassembly and assembly without proper training can result in consequences for which one is responsible.

6.2 Replacement of bearings

Users are not able to replace the bearings themselves due to the need for the entire pump to undergo balancing.

6.3 Impact Protection

A molecular pump is a high-speed rotating machine with very small clearances between the moving and stationary parts. It cannot withstand significant impacts. In addition, there should be limitations on the velocity and acceleration of any moving parts that come into contact with it. Furthermore, sudden influxes of atmospheric gases and the introduction of foreign objects into a molecular pump during normal operation can also result in severe damage to the pump.

6.4 Vibration Isolation

Generally, molecular pumps undergo strict inspections and have minimal vibrations, allowing them to be directly connected to the evacuated system. It is advisable to use vibration isolators to minimize the impact of vibrations on the instrument for applications involving highly precise instruments like electron microscopes.

6.5 Strong Magnetic Field Shielding

Rotating rotors generate eddy currents in a magnetic field, resulting in rotor heating. The use of molecular pumps in strong magnetic fields is subject to certain limitations due to the heat that weakens the strength of aluminum materials.

6.6 Electromagnetic Interference

Some high-frequency instruments, such as molecular pumps and frequency converters, may produce electromagnetic interference in the surrounding environment. However, the application of molecular pumps should not be restricted when international standards are met. Proof of compliance should be provided as necessary. However, the application of molecular pumps should not be restricted when international standards are met. Corresponding documentation should also be provided if the requirements are met.

6.7 Strong Radioactivity Limitations

Most materials will undergo changes in their properties in strong radioactive environments, particularly organic materials such as molecular pump oil and seals, as well as semiconductor components. Molecular pumps are able to withstand radiation intensities of up to 10^5 rad. One can choose materials with better resistance to radiation and use motor-driven power sources in order to enhance radiation resistance. All seals within the molecular pump must be made of metal materials when pumping tritium.

6.8 Fore-Vacuum Pump

At the high-pressure end of the molecular pump performance curve, the inlet pressure transitions from around 200 Pa to 10^{-1} Pa, spanning three orders of magnitude. The pumping efficiency deteriorates as the mean free path of gas molecules decreases. Therefore, using a larger preceding pump in the transitional region will result in a higher pumping speed. The minimum size of the preceding pump should not be less than 30 L/S.

II. B-4200 Molecular Pump Power Supply

1. Parameters and Functions

1.1 Overview

The B-series molecular pump power supply is a numerical control power supply based on IGBT power devices and high-speed programmable devices. It operates with long-term stability and precise parameters. It has protection functions such as frequency tracking from top to bottom, acceleration overcurrent, operation overcurrent, deceleration overvoltage, power supply overheating, and pump overheating.

The B-series molecular pump power supply incorporates a high-efficiency output matching transformer, providing excellent overload capacity and a very low temperature rise. This makes it ideal for long-term, continuous operation. It also comes with a fully equipped external control interface, allowing for the easy assembly of various modes of vacuum equipment and automatic exhaust systems.

1.2 Installation Dimensions

Front panel	Width: 480 mm x Height: 180 mm (Thickness: 2.5 mm)	Minimum Clearance Space from Front Panel to Cabinet Front Door	13 mm
Rear panel	Width: 440 mm x Height: 170 mm	Minimum Clearance Space from Rear Panel to Cabinet	150 mm
Box	D 300 mm x W 440 mm x H 170 mm	Minimum clearance space on both sides of the chassis to the cabinet.	50 mm

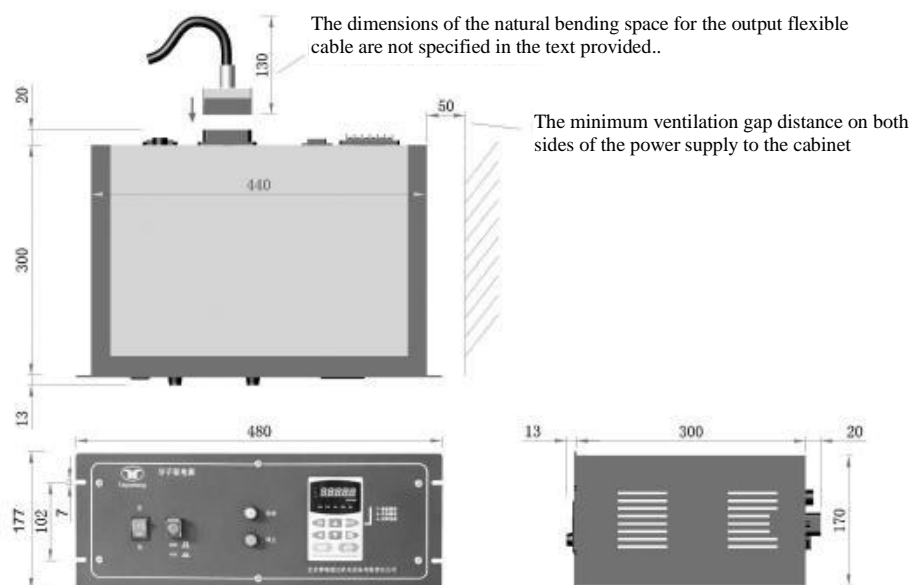

1.3 Electrical Parameters

Output power (overload capacity)	The output power is 1000 W (with an overload capacity of 1500 W). The consumption power is less than 300 W when the molecular pump is operating normally and less than 800 W during startup acceleration.
Output voltage	0 — 50V
Output frequency	0 (10) — 260Hz
Zero-start acceleration time	less than 12 minutes.
Deceleration time	less than 20 minutes
Input voltage	single-phase AC 180V-240V, 50-60Hz
Working conditions	The environmental temperature is 0-40 °C, with a relative humidity of less than 80%. User Zero's start acceleration time is 375. It takes less than 12 minutes.

1.4 Front Panel Button and Interface Functions

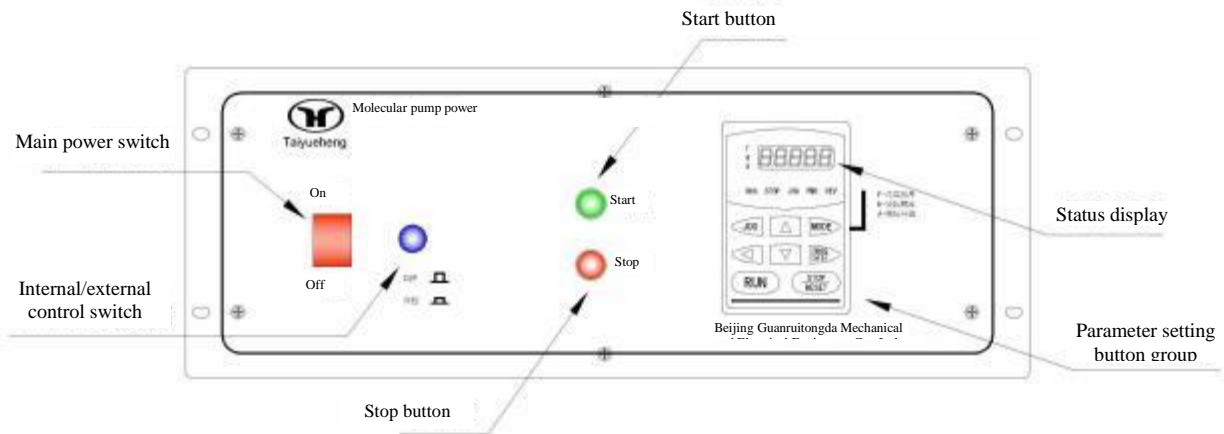

Front panel schematic



Introduction to the Front Panel Switches and Button Functions:

Main power switch	Can connect or disconnect the AC220V dual-wire (L, N) circuit.
Internal/External Control Switch	Determines whether terminals 1 and 2 of the 'external control terminal' are effective. Press for external control (remote control) mode. Points 1 and 2 are valid.
Start Button	After pressing, the molecular pump activates the acceleration state (the frequency tracks down from 260 Hz) until it reaches the highest frequency.
Stop Button	After pressing, the molecular pump enters the deceleration state, decreasing the frequency until it reaches the lowest frequency, and the power supply stops outputting.
Parameter Setting Panel (Valid Operation Button) Explanation	
	Cyclically pressing this button in normal mode (non-programming mode) can inquire about the highest set frequency, actual operating frequency, and current amount (approximately equal to the 220V input current whether the power is off or on, as it is the three-phase output current on the internal 220V side).
Note: The parameter change, forward/reverse, and inching keys, as well as the RUN and STOP function keys, are dedicated keys for factory adjustment. They have been locked after leaving the factory and are invalid for use.	

1.5 Rear Panel Interface Functions



Rear Panel Interface Schematic

1.5.1 'Molecular Pump' Interface (Plug Side) Wire Number and Function Table

No.	Function
1	First Phase Wire U
2	Second Phase Wire V
3	Third Phase Wire W
4	Temperature Switch 1 Wire
5	Temperature Switch 2 Wire (Circuit)
6	Ground Wire (Connected to Connector Housing)

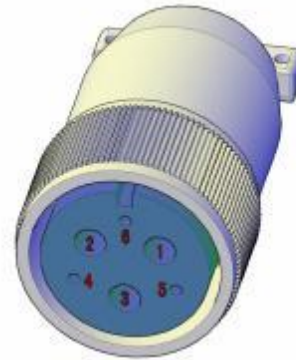

1.5.2 'Power Supply' Rear Panel Output Interface (Socket) Wire Function Table

Interface	Function
1、2、3	Three-phase U, V, and W output, respectively, are connected to 1, 2, and 3.
4、5	Temperature switch
6	Ground Wire (Connected to the Pump Housing)



1.5.4 External Control Interface Function Table and Application Instructions



Interface	Function	Remarks & Parameters
1、 2	External control interface for starting and stopping the molecular pump. Connect to start and disconnect to stop.	'2' is signal ground.
3, 4	Empty	
5, 6	Power and molecular pump alarm fault signal, relay normally closed. Open a circuit in case of a fault.	AC100V/1A , DC24V/1A (Cannot connect to strong electric power above 100V)
7, 8	The output signal reaches 260Hz, i.e., full-speed operation. Relay is normally open. Closes at full speed.	AC240V/1A , DC100V/1A
9、 10	Optional Function. DC 0-10V output, corresponding to indicating 0-260Hz output frequency. It can also correspond to indicating a working current of 0 to 6A for the power supply. (The function of this port needs to be clarified with the manufacturer when placing an order.)	9+ , 10- 。 10 cannot be used as an equivalent to signal ground, but it can be connected to signal ground.
11、 12	10V output frequency synchronized pulse. (The function of this port needs to be clarified with the manufacturer when placing an order.)	11+ , 12- 。 '12' is signal ground.
13、 14	485 Communication Interface (The function of this port needs to be clarified with the manufacturer when placing an order.)	13 is 485+, and 14 is 485-

Note: The 485 communication interface is a function dedicated to manufacturer adjustments and is not recommended for user use. Please refer to the following articles for the application of the external control interface.

2.Regular

Assembly and

Power-on

Testing

2.1 Power

Distribution of

the Entire

Machine and



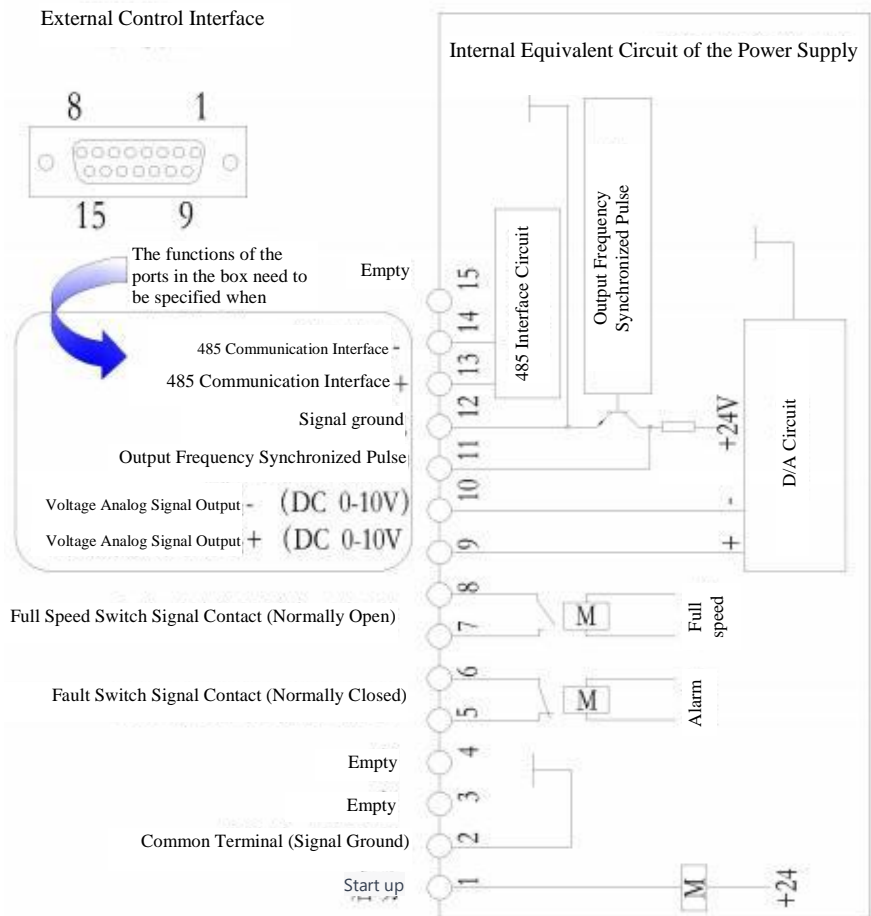

Precautions



External Control Interface Equivalent Circuit Schematic

Wiring Diagram

Instructions and Precautions

	<p>220V Power Cord. Internally, the power supply uses a 10A fast-acting fuse and wires with a cross-sectional area of 1mm² to 1.5mm², inclusive of the wiring of its power supply system.</p>
	<p>Molecular Pump Drive Cable. It is recommended not to exceed 25 meters in length due to factors such as line loss and conservation of non-ferrous metals. You can contact the manufacturer for customization for cables of special length.</p> <p>It is advisable to place the power supply nearby and adopt a remote control solution for control when the distance between the molecular pump and the control system exceeds 10 meters.</p>
	<p> The pins here are prone to tilt or break, and the direction and angle must be confirmed before insertion.</p> <p> Plugging and unplugging while powered is prohibited. The cable can only be plugged in or unplugged when it is confirmed that the power supply is not working or is completely powered off.</p>

2.2 Application of Remote Control Interface









Generally, there are multiple molecular pumps in large-scale continuous vacuum (LCD, special glass, etc.) production line equipment. In addition, the control panel is relatively far from the molecular pump. Extending the drive line of the molecular pump will result in increased costs, the trouble of laying cables along the way, the possibility of increased peripheral circuit interference, and energy loss due to line loss, etc. Adopting a remote control solution is an ideal choice.

The equipment is often designed as a fully automatic control system in some vacuum equipment as a result of the 'exhaust' and even 'packing' work being very frequent. Therefore, it is necessary to exchange information with the molecular pump during the equipment's operation. The B-series molecular pump power supply also provides you with this supporting function.

Wire Number and Function Name	Application Schemes and Instructions
1, 2 Start/Stop	<p>The internal operation signal relay of the power supply will act when 1 and 2 are connected. The voltage is 24V before connection, and the current is 15mA after connection. This interface can be directly controlled by the PLC. Please pay attention to the polarity (2 negative) if it is a PLC with transistor output.</p>
5, 6 Fault Signal	<p>5 and 6 are normally closed switch signals. Contact parameters are: AC 100V/1A, DC 24V/1A. The fault signal contact opens when the power supply fails and remains closed when the power supply is off. Generally, this signal can control the safety gate valve located at the molecular pump's mouth in order to close the gate valve in time and maintain vacuum.</p>
7, 8 Full Speed Signal	<p>7, 8 are normally open switch signals. Switch contact parameters are: AC 240V/1A, DC 100V/1A. This switch closes after the power supply starts, since the power supply starts by tracking downward. It opens below 240 Hz and closes again as the frequency tracks upwards and the power supply accelerates to 260 Hz, at which point the acceleration process ends and the pump enters full-speed operation. (It is best to install a 10–20 second delay relay here when using this function.)</p> <p>The normally open switches are all in the released state (open circuit) when the power supply fails or is powered off. Therefore, the full-speed signal is more useful than the fault signal. It is the only signal indicating that the molecular pump is operating normally. The full-speed signal can be used as a marker signal for the normal operation of the molecular pump.</p>
11, 12 Synchronized Pulses	<p>11, 12 leads output pulse signals synchronized with the power supply output frequency, with a pulse strength of 10 V. A general digital frequency meter can be connected to remotely monitor the output frequency of the power supply. The 0-10V analog output at points 9 and 10 also reflects the 0-260Hz frequency.</p>

III. Conventional Operation Procedure Based on B-Type Power Supply

1、Regular Operation Flow Chart

Start, Accelerate to Normal Operation		
1	<p>Power On Initialization</p> <p>Display: </p>	<p>Turn on the power switch, the LED digital display shows the  actual output frequency (i.e., the current output frequency), and the power supply is all normal.</p> <p>Press the MODE button multiple times. The LED digital display window will alternate between displaying 260HZ, indicating the set frequency is 260Hz, the  actual output frequency (i.e., the current output frequency), and the  actual output current (internal output side three-phase 220V phase current, approximately equal to the power supply 220V/AC input current. The unit is Ampere), etc.</p>
2	<p>Exception Handling</p> <p>Display: </p>	<p>The LED digital display window will give the corresponding alarm code (refer to the alarm code comparison table) when powering on is abnormal. The common one is , indicating that the connection cable between the power supply and the molecular pump is not properly plugged in, there is an internal break in the cable, or the molecular pump's body is overheated. You can directly use insulated tweezers or the wire's conductive part to short-circuit the power output interface's temperature control electrode at pins 4 and 5 of the output aviation plug. If the alarm disappears, it indicates that the power supply is normal. Primarily, check whether the cable connector is securely connected and whether the pump body is obviously over 50°C. If the pump body temperature is too high, it is usually caused by insufficient cooling water flow, and the waterway should be checked for blockages. (For air-cooled pumps, check whether the fan is rotating or whether the room temperature exceeds 28°C. Also, appropriately adjust the equipment site's air conditioning system to lower the room temperature.)</p>
3	<p>Check the vacuum system and the condition of the molecular pump to confirm that the molecular pump can be safely started, then press the start button, and the molecular pump enters the acceleration process.</p>	<p>Check if the vacuum level above the inlet of the molecular pump, in the vacuum chamber, or in the gas path is already below 30Pa and if the foreline pump is working properly. The blades of the molecular pump are in motion or stationary. Press the green start button on the front panel of the power supply. The molecular pump power supply starts to track downwards from 260 Hz, accelerates until the speed increases, the frequency rises, and then reaches 260 Hz for full-speed operation.</p> <p>The molecular pump can be started and accelerated once the foreline pump is started in the case of small vacuum systems because the mechanical pump takes less than 2 minutes to reduce the air pressure in the vacuum chamber to below 10Pa, while the molecular pump needs at least 10 minutes to accelerate. Therefore, the molecular pump can be started as long as it is confirmed that the mechanical pump has started properly and there is no leak in the vacuum chamber. An accelerating molecular pump helps to increase the foreline pump's pumping speed.</p>
4	<p>Observe the output current to monitor the operating load condition of the molecular pump.</p>	<p>You can press the MODE button multiple times to observe the  current parameter depicted, if necessary. This parameter is the internal 220V output phase current (transformed to 50V output by the internal transformer). The acceleration current is less than 4 A under good conditions in the vacuum chamber and foreline pump and after full-speed operation. The current will remain below 1.7A if the condition of the vacuum chamber is excellent (no significant leak). Attention should be paid to checking whether the foreline pressure is higher than 100Pa if the current remains above 4.3A during the acceleration process, causing an excessive load on the molecular pump. The molecular pump power supply will stop output and issue an over-rotation fault alarm signal  if the current continuously exceeds 5A.</p> <p>The molecular pump power supply will track the frequency downward and then accelerate to normal if the molecular pump power supply is started and the blades of the molecular pump are in high-speed operation due to not decelerating during the last run. If the operating speed is close to the rated speed, then the molecular pump power supply directly reaches 260 Hz full-speed operation.</p>
Deceleration, stopping, system inflation, and power-off.		
1	<p>Press the red stop button</p>	<p>The molecular pump power supply will use a frequency reduction braking method to quickly stop the rotation of the molecular pump when you press the front panel red stop button. This process takes about 12 minutes.</p>
2	<p>System Inflation Power Off</p>	<p>Wait until the output frequency of the molecular pump power supply reaches , then you can turn off the power. Wait for approximately 10 minutes until the molecular pump is completely stable, and then the vacuum system can be filled with nitrogen or dry air. Do not fill with gas until the molecular pump has completely stabilized!</p> <p>Note that the pump motor will feedback energy to the power supply if you turn off the power prematurely during the deceleration process, maintaining a certain self-sustaining power during the braking process. Also, the power supply will continue to operate (the display will show deceleration). The power supply will automatically shut off when decelerating to half-speed operation. This phenomenon is normal. However, you cannot casually unplug the cable of the molecular pump when this phenomenon occurs, because even though the power supply is off at this time, there is still energy exchange between the power supply and the molecular pump. The power supply's power components may be accidentally damaged if you unplug the cable due to the load switching jitter caused by plugging and unplugging.</p>

2.Explanation of the Alphanumeric Display on the Digital Screen

	The header is "F." The following numerical value represents the set frequency.		The header is "A." The following numerical value represents the actual output current of the frequency converter.
	The header is "H." The following numerical value represents the actual output frequency.		The header is "D." The power supply is operating in parameter adjustment mode, and the following numerical value represents the parameter value.
	The power supply is operating in programming mode. The following number is the function number.		

3.Alarm Code Comparison Table and Solutions

Alarm Display	Explanation and Solutions	Alarm Display	Explanation and Solutions
	If there is a short circuit on the output side of the power supply during operation, you should check the cable and the winding of the pump motor for short circuits.		In cases of overcurrent during operation, check whether the output lines are short-circuited or loosely connected.
	The internal line voltage of the power supply is too high. Check if the molecular pump brake is too fast and if the power supply voltage is too high.		The molecular pump temperature is too high, or the molecular pump drive cable is not properly connected. Check the water flow to the pump. For air-cooled pumps, check the fan and consider lowering the room temperature if necessary.
	The power supply temperature is too high. Consider turning on the facility's air conditioning system. Try to maintain an ambient temperature below 40°C.		Power supply program error, turn off the power, and restart.
	The supply voltage is too low. Check if the system supply voltage is insufficient (it's normal for the alarm to occur during shutdown).		Power supply program error, turn off the power, and restart.
	The power supply is overloaded. Overload during molecular pump operation.		Power supply output leakage; send it back for repair.
	Re-acceleration from 0 Hz during high-speed operation of the molecular pump leads to overloading during acceleration. Restart acceleration after resetting.		Power supply self-check failed. Restart the system. If the alarm persists, send it back for repair.
	The foreline vacuum level is too low. Check if the foreline pump and foreline valve are open. Or the pump blades are stuck (send for repair).		Temporary output stop. Caused by internal circuit abnormalities. Send it back for repair.
	Sudden increase in current during acceleration. In addition to the above solutions, check if the output cables are short-circuited or loosely connected.		Power supply circuit abnormality. Send it back for repair.
	Overcurrent during deceleration. Check if the output lines are short-circuited or loosely connected.		

IV. Common Faults and Troubleshooting

1.Common Faults and Troubleshooting Table

Fault	Analysis and Troubleshooting Methods	Fault	Analysis and Troubleshooting Methods
Molecular pump. Fail to start	Power supply failure— (Refer to the powersupply section of this manual). Cable connection is not established—(Use a multimeter to check cable connections and ensure socket contacts are good). Other reasons—(Please contact the manufacturer).	Even after some time, it doesn't reach the rated speed or stops.	Vacuum system leakage—(Inspect for leaks and blockages. The foreline pressure should be below 10Pa). Bearing damage—(Check for rotor movement without heavy friction. Damaged bearings should be replaced at the factory).
Excessive vibration and noise during pump operation.	The pump operates within the resonance frequency range—(Change the installation position and connection dimensions, secure the moving parts, or add or remove vibration damping rubber pads). Pump imbalance—(If the pump still exhibits excessive vibration and noise during a separate test run, it should be sent to the factory for repair). Bearing damage—(Send for factory repair and bearing replacement).	Low vacuum level	Foreline vacuum pipe leakage—(Inspect and seal foreline vacuum pipe leaks). High vacuum pipe leakage—(Inspect and eliminate high vacuum pipe leaks). Regulator gas flow is high—(Evacuate the regulator cathode and bake the regulator at 200°C for 2 hours). Foreline pump malfunctions—(Inspect and troubleshoot).
After baking, the ultimate vacuum index is not reached.	High foreline pressure—(Foreline pressure should be below 10Pa). Foreline pump speed is insufficient—(It should not be less than the minimum specification recommended for the foreline pump in Table). Contamination between the pump and the vacuum system—(Clean the vacuum system and send the pump for cleaning at the factory).		

V. Inventory and Unboxing

1.Inventory

A molecular pump is a highly clean-demanding mechanical product. The cleanliness of its internal blades directly affects its ultimate vacuum performance. Therefore, the molecular pump's inlet and outlet must be sealed during storage, and the interior must be kept clean and dry. It should not be stored in a humid or dusty environment.

2.Unboxing

Packing List				
S/N	Name	Unit	Qty.	Remarks
1	TYFB--4200 Turbo Molecular Pump	Set	1	
2	Molecular pump power	Set	1	
3	Molecular pump cable	Sets	1	Standard length: 8 meters.
4	Molecular pump oil	Bottles	2	
5	User Manual	Copy	1	
6	External Control Interface	Sets	1	
7	10A fuse tube	pcs	2	
8	Center support	Sets	1	
9	M10 caliper screw	Sets	4	
10	M12 caliper screw	Sets	8	
11	Inspection certificate	Copy	1	
12	Warranty	Copy	1	

Warranty Information

With a warranty slip, our TY series molecular pumps are guaranteed for one year from the date of purchase. Customers from other regions can extend the warranty by one month. There are no repair charges during the warranty period. Half of the cost is generally charged if parts need replacement and can be provided free of charge for up to six months.

The warranty does not cover the following cases:

1. User disassembly of the product.
2. Improper storage or use by the user.
3. Damage caused by other reasons attributable to the user.

Warranty form

Product Name: Turbomolecular Pump

Product Number: _____

Date of manufacture: _____

User: _____

Date	Maintenance content	Maintenance person	Remarks

Cut Open

Seal Here

Please have the user fill out the following details and return them to our company for reference.

Product Name: Turbomolecular Pump

Contact Person: _____

Product Number: _____

Contact Phone Number: _____

Date of Manufacture: _____

Postal Code: _____

Date of Purchase: _____

Name of unit: _____

Company Address: _____