

BSV SERIES INSTRUCTION MANUAL



TWO-STAGE ROTARY
VACUUM PUMPS

NINGBO BAOSI ENERGY EQUIPMENT CO., LTD.

Contents

1	Introduction.....	1
1.1	Scope and definitions.....	1
1.2	Importance.....	2
2	Description.....	4
3	Technical Data.....	5
3.1	Performance.....	5
3.2	Dimensional drawing.....	6
4	Installation.....	10
4.1	Locate the pump.....	10
4.2	Fill the pump with oil.....	10
4.3	Electrical installation.....	11
4.4	Check the direction of rotation.....	12
4.5	Inlet.....	12
4.6	Outlet.....	13
4.7	Operation.....	13
5	Gas Ballast Function.....	14
6	Maintenance and Check.....	15
6.1	Regular check.....	15
6.2	Vacuum pump oil check.....	15
6.3	Change the pump oil.....	16
6.4	Abnormal noise and vibration check.....	17
6.5	Checking the metal mesh at the inlet port.....	18
6.6	Pump stopping and storage.....	18
7	Disposal.....	18
8	Warranty Clauses.....	19
9	Disclaimer Clauses.....	19
10	Main Replaceable Parts.....	20
11	Trouble Check List.....	22

1 Introduction

Thank you very much for using our products.

You are kindly requested, upon delivery of the product, to check that the delivered product is exactly what you have ordered and it has no damage caused by transport or the like. If there is any damage, defect, or missing parts, please do not hesitate to contact with us.

1.1 Scope and definitions

This manual provides installation, operation and maintenance instructions for the BSV10, BSV16, BSV24, BSV30, BSV40, BSV60, BSV90 rotary vacuum pumps. You must use your pump as specified in this manual. Read this manual before you install and operate pump.

You are requested to install and operate the product in compliance with the laws and regulations relating to the safety, e.g. Fire Defense Law, Electric wiring regulation and so on in the country and region you use the product. Operators shall need to attend related training and have special knowledge, skill and title regarding the electricity, machinery, cargo, vacuum and so on.

Important safety information is highlighted as WARNING and CAUTION instructions; you must obey these instructions. The use of WARNING and CAUTION is defined below.



WARNING

Warnings are given where failure to observe the instruction could result in injury or death to people.

CAUTION

Cautions are given where failure to observe the instruction could result in damage to the equipment, associated equipment and process.

The units used throughout this manual conform to the SI international system of units of measurement.

The following symbol is on the pump.



Warning - refer to accompanying documentation.



Warning – risk of electric shock.



Warning – hot surfaces.



CONFORMITE EUROPEENNE - Comply with the EU "technical coordination and standardization of new method" basic requirements of the directive.



WEEE - When the end user is going to discard the product must be sent to the appropriate facilities, for recovery and recycling.



The direction of motor - Ensure that the pump-motor rotates in the correct direction.

1.2 Importance



WARNING

Operations not comply with the following protective measures will result in significant personal injury and equipment trouble!

- ◆ Be sure to turn off the power supply to execute the wiring and maintenance work. You are recommended to install a dedicated Leak breaker. You have a risk of getting electrical shock in case of failure or electric leakage.
- ◆ Do not run the pump on blocking the exhaust outlet or putting any device that might hamper gas passage onto the outlet. There is a risk that the pressure inside the vacuum pump will rise up to cause break of the casing or the oil level gauge, resulting in overload of the motor. When utilizing the oil mist trap perform the periodic maintenance so that no-resistance can be realized in passage of gas.
- ◆ Ensured pressure value of the pump is not over 0.03MPa (0.3kg/cm²) (gauge pressure). Check the exhaust side pressure of the pump. If it was over 0.03MPa, take away anything in and around the exhaust outlet that hampers gas passage.
- ◆ Do not exhaust any hazardous gas such as explosive, combustible and toxic. If any toxic gas was evacuated, not only the pump itself but also vacuum pump oil get toxic. Keep this in mind when perform maintenance, ask the special agency to do the detoxification process.
- ◆ Do not exhaust any gas which oxygen content is greater than atmospheric oxygen (the oxygen content>21%) or other strong reactive gas.
- ◆ The motor and pump become hot (temperature increase under non-load operation : 40°C, temperature increase under high-load 80°C)during operation, there is a risk of burns. Do not touch the motor and pump during operation or soon after pump stopping. Apply an appropriate protection to avoid touching the surface as necessary.

- ◆ Never place combustible materials around the motor or pump. There is a risk of fire. Also, do not place objects that block ventilation around the motor. Abnormal heat generation may result in burns.
- ◆ Do not operate the pump in hazardous area (where there is a risk of creating hazardous atmosphere by explosive gas). It might cause injury and fire.
- ◆ Any non-professional person shall be restricted from disassembling, repairing or modifying the product. It might cause a fire, be injured, or pump trouble.
- ◆ Be sure there is no debris or powder and lots of condensed gas generated or accreted in system, the pump will be damaged because of oil being deteriorated.
- ◆ You should check the oil level regularly.
- ◆ Do not operate the pump without pump oil or in an oil-less condition, the pump will be damaged.
- ◆ Ambient temperature for operation should be 5 to 40°C. When the pump is installed in a closed system, be sure the ambient temperature not more than 40°C.
- ◆ It is imperative to put the overload protection device. Otherwise it would cause the motor burn out and/or fire.

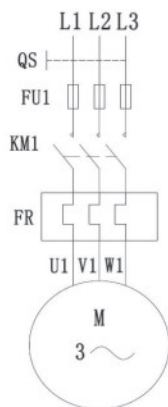

L1 L2 L3: Three-phase ac power supply

QS: Air switch

FU1: Fuse / Circuit breaker

KM1: Contactor

FR: Thermal relay

U1 V1 W1: The motor terminal

M3~: Three-phase ac motor

* Each protection device must comply with EU standard and certified by EU authorities

Fig.1 Motor wiring diagram (example)

2 Description

The BSV series pumps are compact, low noise, two-stage, oil-sealed, high-vacuum pumps designed for reliable, long-term operation in both laboratory and industrial environments. A four-pole three-phase motor provides direct-drive through a flexible coupling.

Features of the pump include the following:

1. High maintainability

Because of integrated cylinder structure and pin connection, maintenance and inspection can be done easily and accurately. Daily check (oil level check, oil filling, and oil change) can be performed from one direction.

2. Forced lubrication pump system

The stable performance can be obtained in the vicinity of the atmospheric pressure.

3. Hydraulic oil anti-sucking system

If the power fails or the pump is stopped for a long time without venting the inlet side to atmospheric pressure, the pump oil will flow back to the cylinder, making restart difficult. This pump is equipped with the oil anti-sucking feature to minimize the amount of oil flowing back to the cylinder and to reduce the load, pump can restart easily.

4. Variable oil level system

This pump has a wide oil level indicating range to allow easy control of oil level. The pump is operable if the oil level is between the two level lines of the oil level gauge during operation.

5. Gas ballast function

This proves effective when pumping condensable gas, such as water content, organic solvent and the like.

3 Technical Data

3.1 Performance

Table 1 Performance data

Model		BSV10	BSV16	BSV24
Pumping speed m ³ /h	50Hz	9.9	14.4	20
	60Hz	12	17.4	24
Ultimate pressure Pa	GP open	5		
	GP close	0.5		
Motor kW	380V (3 phases)	0.4 (4poles)	0.55 (4poles)	0.75 (4poles)
	220V (single phase)			
Inlet		KF25		
Outlet		KF25 (G1)		
Vacuum pump oil		BSO 68		
Oil capacity	L	1.1	1.2	1~1.5
Weight	kg	25	27	32

Table 2 Performance data

Model		BSV30	BSV40	BSV60	BSV90
Pumping speed m ³ /h	50Hz	30	40	60	90
	60Hz	36	48	72	108
Ultimate pressure Pa	GP open	3			
	GP close	0.5			
Motor kW	3phases 4poles	1.5	1.5	2.2	3.7
Inlet		VG40		VG50	
Outlet		KF40 (M50X1.5)			
Vacuum pump oil		BSO 68			
Oil capacity	L	1.2~2.8		2.5~4.2	
Weight	kg	63	65	87	101

- The ultimate pressure is the value indicated on the Pirani gauge when the standard oil BSO 68 is used. The ultimate pressure when the Mcleod gauge is used is approx. One digit lower than the value indicated on the Pirani gauge.
- The type of rotary pump oil differs depending on vapor pressure, viscosity, etc. The use of a wrong type of oil can lower the pump performance. So use the pump oil recommended BAOSI.
Recommended type of oil: 1) BSO 68 (standard oil)
2) BSO 46 (oil for use in cold season)
- GP is abbreviates by gas ballast valve.

3.2 Dimensional drawing

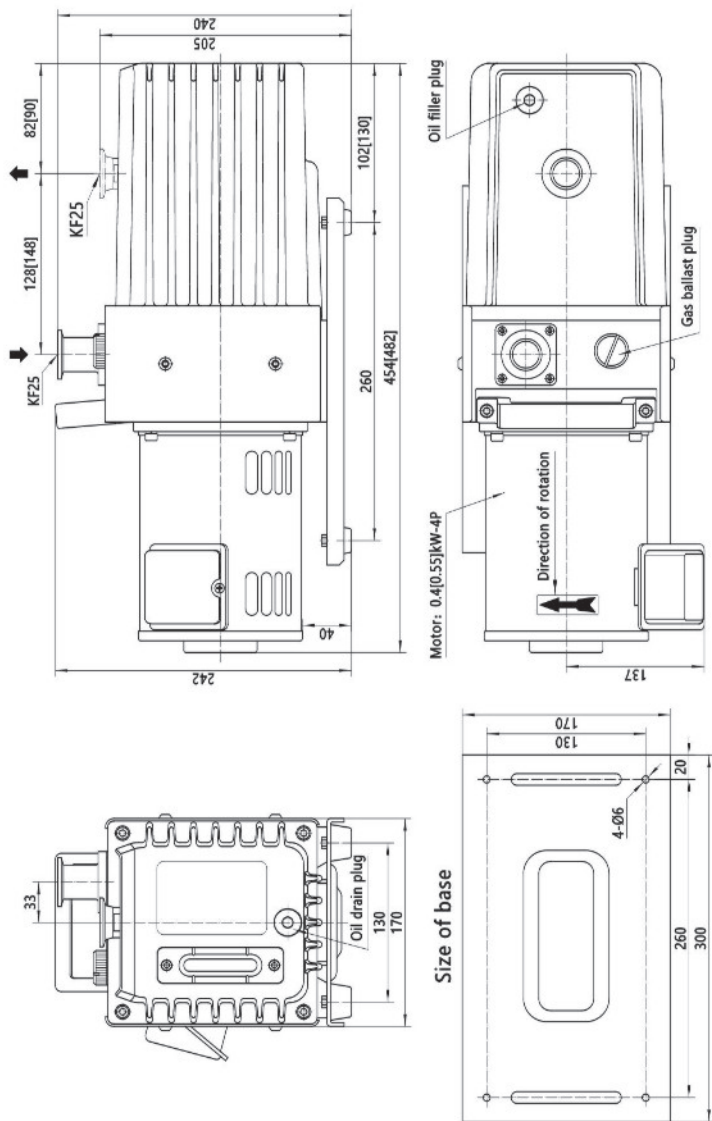

Fig.2 BSV10 [BSV16] Dimensional drawing

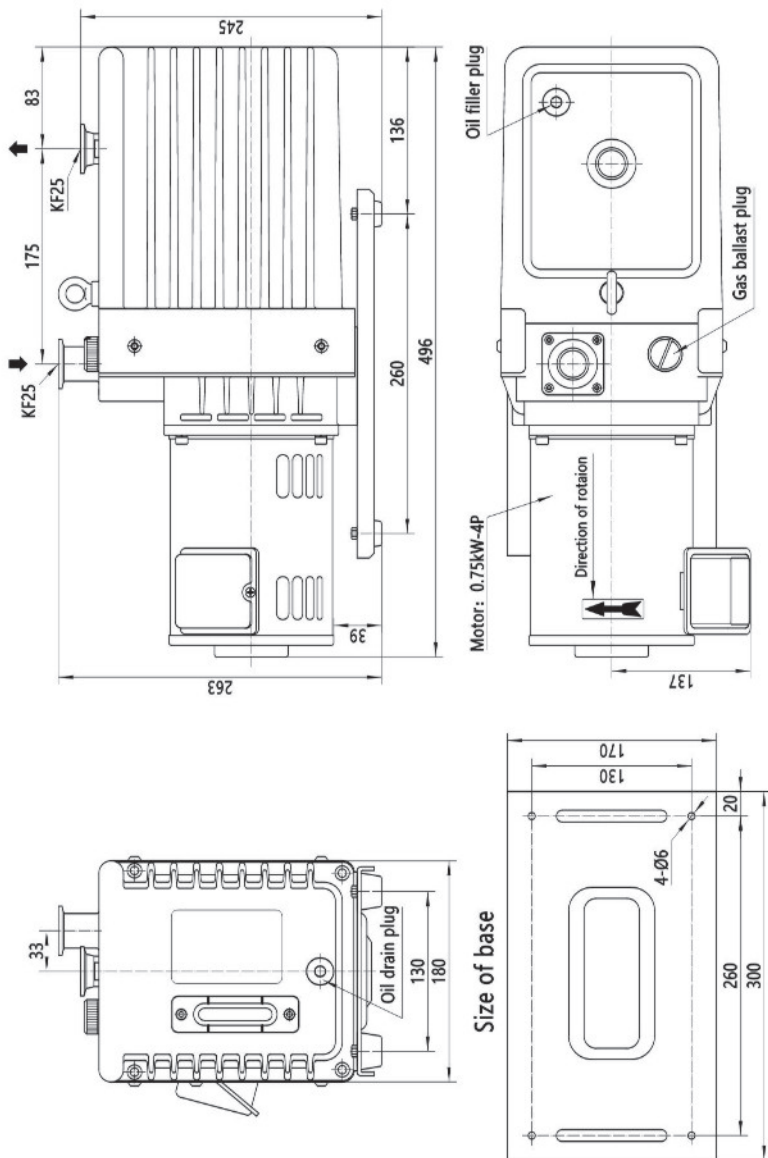

Fig.3 BSV24 Dimensional drawing

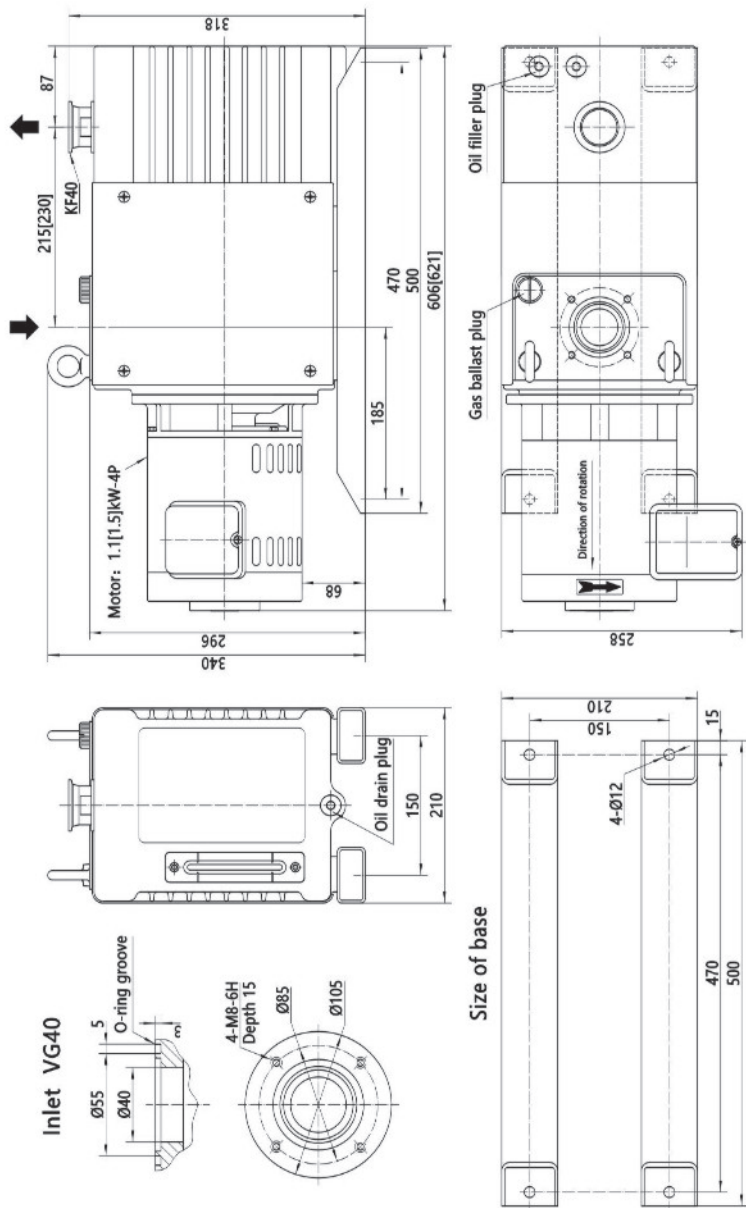

Fig.4 BSV30[40] Dimensional drawing

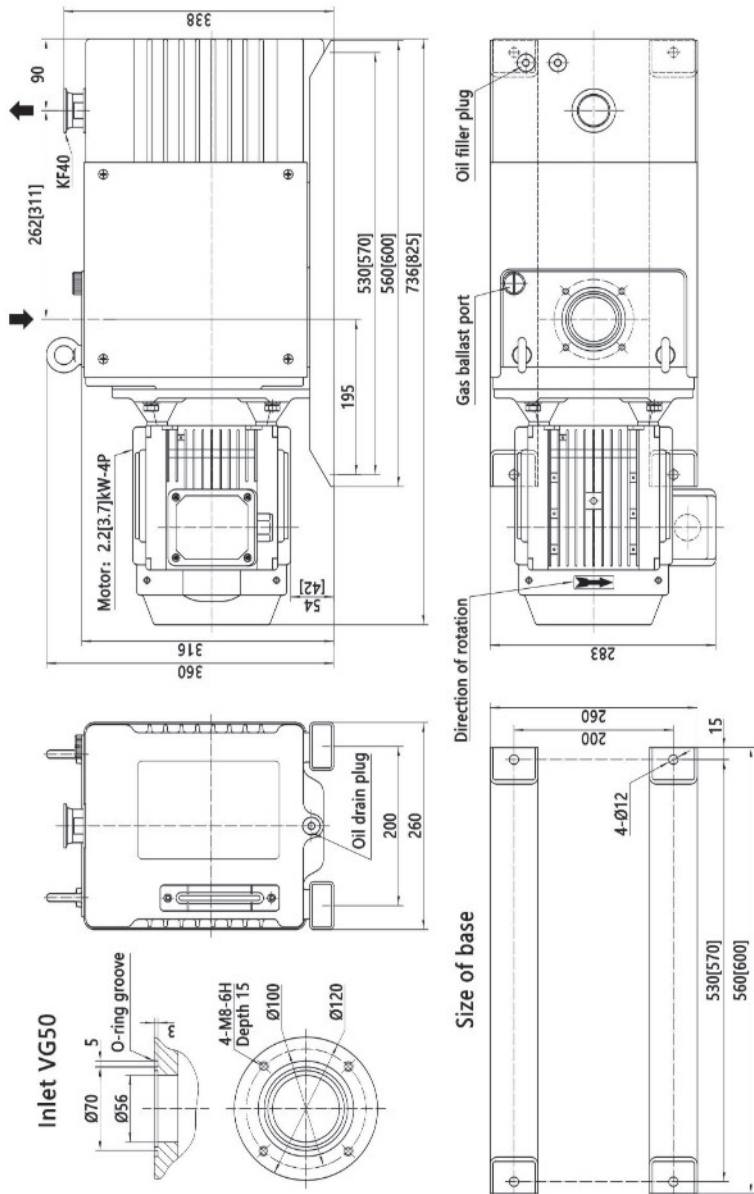

Fig.5 BSV60[90] Dimensional drawing

4 Installation

4.1 Locate the pump

Install the pump horizontally to a place where are less dust and humidity. Ambient temperature for operation shall be 5 to 40°C. The layout arrangement should be considered for setting up, overhaul, checking or cleaning the pump.

The pump is equipped a handle and rubber isolators as standard. If it's equipped in a precision instrument, be sure to install it flatly and no gaps between the pump and installation surface, tighten bolts to fix it.

CAUTION

Instable installation will increase noise level or result in pump damaged, make sure to install the pump on a flat place.

4.2 Fill the pump with oil

It is recommended that you use the BSV 68 vacuum pump oil. The ultimate vacuum of the pump with other oils may be higher than the ultimate vacuum with the recommended oil.

Filling the pump with oil as described below.

1. Remove the filler-plug.
2. Pour oil into the pump until the oil-level between the MAX and MIN mark indicated on the sight-glass. If the oil-level goes above the MAX mark, open the oil drain-tap the excess oil from the pump.
3. After a few minutes, recheck the oil-level is below the MIN mark, pour more oil into the pump.
4. Refit the oil filler-plug. Tighten the plug firmly by hand. Do not over-tighten.

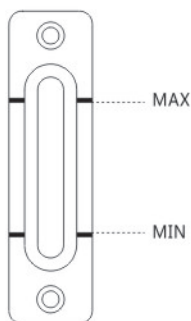

Fig.6 Oil level indication

4.3 Electrical installation



WARNING

Before connecting wires, you must turn off the power switch. If not, an electric shock will occur. Connect the earth wire correctly.

Install a suitable overload protector for capacity of the motor, otherwise the motor will be damaged leading to fire.

Connect the wires according to indication on the motor nameplate.

This pump can be used with no trouble practically for fluctuation range of power voltage and frequency as shown below. But this only means no significantly shortening life time of the pump, no conforming to the rating value of characteristics will cause temperature rise.

Fluctuation of power voltage $\pm 10\%$

Fluctuation of frequency $\pm 5\%$

Total value of simultaneous fluctuation of power voltage and frequency within $\pm 10\%$

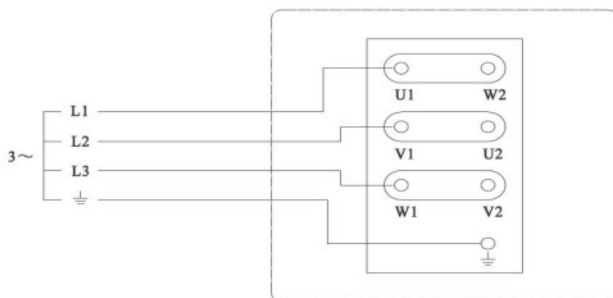

Fig.7 Triangular connection

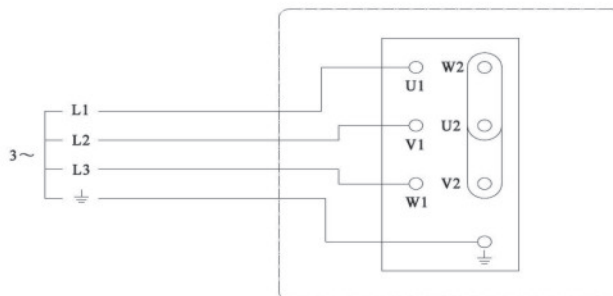

Fig.8 Y-connection

4.4 Check the direction of rotation



WARNING

The direction of rotation is as indicated by the arrow mark cast on the motor fan cover.

Ensure that the pump-motor rotates in the correct direction. If it does not, the pump and your vacuum system can become pressurised.

If it is reversed, interchange K1 and K2 for single phase motor and interchange two of the three wires for three phase motor.

4.5 Inlet

The pipe caliber connected to the inlet port should not be smaller than the inlet port diameter. Otherwise the pumping speed will be decline.

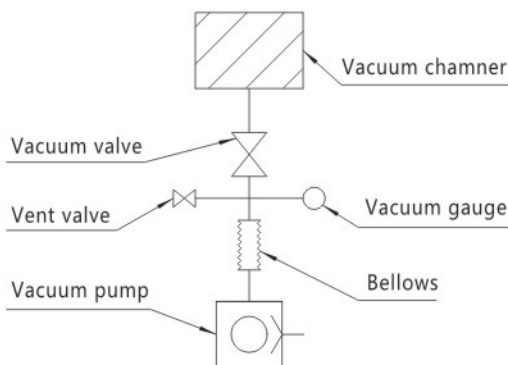

Fig.9 Connection vacuum chamber (example)

CAUTION

Vent valve is to prevent pump oil or oil vapor anti-sucking to vacuum chamber when the pump stopping. Install it closer as possible to the vacuum chamber Install it on the inlet port of the mechanical booster pump if the pump is used together with booster pump.

If the pump sucked the water or substance such as dust, powder and soon, it would impair the ultimate pressure and further cause trouble.

Metal mesh on the inlet port is to keep foreign substances away from the pump unit. Be sure not to take it out unless necessitated so to check it.

4.6 Outlet

The pipe caliber connected to the outlet side should not be thinner than the outlet diameter. Otherwise there is a risk that the pressure inside the pump will rise up to cause break of the casing or oil level gauge, or overload of the motor.

Oil mist would appear through the exhaust side when the pump running around high pressure range, discharge it to outdoor or an oil removing device through exhaust piping. It is recommended to use an oil mist trap to reduce oil consumption and to trap oil mist.



WARNING

The pump is not made as the withstand pressure structure.

Ensured pressure value of the pump is not over 0.03MPa (gauge pressure).

Ensure exhaust side keeps clear when the pump running.

4.7 Operation

1. The pump can start and run under any pressure which not higher than atmospheric pressure. If the environment temperature is not lower than 10°C, pump can start without any difficulty. If there is electromagnetic valve equipped on the inlet port, it should be started at the same time with pump starting.
2. During pump operating, if the air inlet side suddenly exposed to the atmosphere because of accidently trouble (system damaged etc.), you should stop the pump as soon as possible, close the pipe which connecting with the system to avoid the pump oil splashing out.
3. High working environment temperature will lead to the ultimate vacuum worse.
4. The ultimate pressure of the pump, the value measured from compression mercury vacuum gauge should prevail. Connect vacuum gauge which was full pre-pumped and calibrated directly to the inlet port, if the pump temperature goes to stabilize, the ultimate pressure can be reached after pump running 30 minutes.
5. The pump becomes hot during operation (40 to 80°C). Do not touch the motor, pump unit and pipes during or just after stopped operation while the pump unit remains very hot. Apply an appropriate protection to avoid touching the surface as necessary.



WARNING

The oil temperature reaches 70 to 80°C on continuous operation for hours under high suction pressure. Perhaps parts inside the pump are damaged if the oil temperature higher than 80°C. Check the pump or contact with us.

5 Gas Ballast Function

This product is installed with the gas ballast function (G3/8 plug screw in the gas ballast port) as standard. It can be used with connecting needle valve or pipes. The gas ballast function is applicable to exhaust the condensed gas such as water vapor or solvent vapor.

Breathed condensed gas shall be liquefied through the compress process of the pump, mixed with the pump oil and then cycled mixed together inside the pump unit. This status brings you the same situation that you used the high steam pressure oil that raises the ultimate pressure. It also shortens the life cycle of the shaft seal since the oil lubrication shall deteriorate.

Import the air or dry nitrogen through the gas ballast port just before the pump compression process, the condensed gas (such as water vapor or solvent vapor) is not liquefied but exhausted with the air through the exhaust valve, it called gas ballast function.

To use the gas ballast, breathe in the air through the gas ballast port before sucking in condensed gas and operate the pump around twenty minutes, this is because the "gas ballast effect" becomes larger as the pump temperature is higher. Wait until the pump temperature rises around 70°C to open the vacuum valve to operate the pump. The "gas ballast effect" under lower temperature shall be lower than the specified process performance.

You also have to note that the condensed gas might remain in the pump oil after you have exhausted a lot of condensed gas or exhausted the condensed gas without opening the gas ballast port since the process capacity of the condensed gas by the gas ballast port is limited. In such case, close the vacuum valve, breathe in the air through the gas ballast port and idle operate the pump. Then the oil temperature shall rise up and the oil will be cleaned by means of the gas ballast effect. Keep on idle operating the pump with opening the gas ballast port until the specified ultimate pressure is attained. You need to replace the pump oil if it was not cleaned (the specified ultimate pressure can't obtain) after operating a long time.

CAUTION

The vacuum pump gets high temperature during operation. As the gas ballast port also gets high temperature, be sure to wear protective gear such as a pair of gloves.

Ensure close the gas ballast port to start operating the pump. The oil might jet out of the gas ballast port during the operation around high pressure range.

CAUTION

Keep the gas ballast port closed when not exhausting the condensed gas.

If you kept opening the gas ballast port when not exhausting the condensed gas, it might cause the oil splash, power loss or ultimate pressure rise.

Also, Opening the gas ballast port will increase the temperature rise, noise level and oil mist volume.

6 Maintenance and Check

6.1 Regular check

You should check following points at least once per three days during operation. Check the machine much more frequently during high overload operation (continuous operation 1kPa or more, repeated exhaust atmospheric pressure-vacuum).

1. Whether the pump oil volume is between two level lines or not.
2. Whether the pump oil is discolored or not.
3. Whether there is no abnormal noise.
4. Whether there is anything strange in the motor current value.
5. Whether there is no oil leak from the pump.

6.2 Vacuum pump oil check

The pump oil will be gradually deteriorated not only by contamination with sucked gas, but also by temperature rise during pump operation. If pump is operated using pump oil containing much content, the ultimate pressure will rise, leading to poor function of the mechanical friction parts of the pump. In the worst case, the pump will seize up and cannot be rotated. Check the oil for contamination, viscosity and discoloring periodically.

CAUTION

The oil level gauge is for checking the pump oil level. Since the oil is not circulating between the pump case and the oil level gauge, contamination or discoloring of the oil may not be observed on the oil level gauge. Periodically drain approx. 50ml oil through the drain port and check the oil for contamination and discoloring.

Visual inspection

The pump oil should be clean and transparent.

If the oil color gets reddish brown, dark brown and cloudy white, please replace the oil. The replacement cycle depends on the application, keep the check records and change the oil regularly.

Pump oil level check

The pump oil should be between the two level lines on the oil level gauge when pump operating. If oil level is under the MIN line, exhaust valve can't be sealed so that ultimate pressure can't obtain. If oil level exceeds the MAX line, a lot of oil will splash out from the outlet port when pump running at atmospheric pressure.

CAUTION

Continuous operation one hour or more at high pressure (1kPa or more) would decrease the oil volume that are discharged as the oil mist and cause parts wear rapidly or cause trouble such as burning.

You are recommended to control the oil level on regularly supplying the pump oil. It is recommended to install the oil recovery mechanism (Option).

Continuous operation at high pressure; the oil temperature becomes very high. As a result, the oil rapidly deteriorates, and the attained pressure and the exhaust speed go bad, and it causes the rapid abrasion of the parts or burns.

Frequently perform replacement of the pump oil and shorten the maintenance cycle.

6.3 Change the pump oil



WARNING

Wear protective gear such as rubber gloves, protective goggles and the like.

There might be some hazardous substances in pump oil because of oil decomposition or hazardous gas sucked in, confirm the nature of the hazard and take necessary safety gear.

The oil level comes down approximately 1cm after pump being started. Do not operate the pump with the minimum oil level. Do not operate the pump before filling pump oil, the pump will be damaged.

To ensure the pump function and the service life, the pump oil must clean and keep in appropriate oil level.

Because of improper storage or use, there might be water or other volatile substances mixed in pump oil and the ultimate pressure cannot attain. Close the air inlet, open the gas ballast port and run pump continuously for 30 minutes to exhaust the gas. If the pump oil was deteriorated by mechanical impurities or chemical contamination, replace the pump oil. You are recommended to fill the pump with clean BS0 68 oil. To change the pump oil as follows.

Shut down the pump and open the oil drain port to drain the oil in the pump case. Up on completion of draining the oil, close the drain port again and ran the pump under no load for approx. 5 seconds to drain the oil from the cylinder.

Close the drain port and fill fresh oil through the oil filling port. Pour oil until the oil level comes between the two level lines of the oil level gauge.

If the oil is severely contaminated, fill fresh oil and run the pump for several minutes under no load to clean the pump interior. Repeat this operation several times depending on the degree of oil contamination.

After changing the oil with fresh oil, run the pump to warm it up and then check the ultimate pressure. If substances of low boiling point (water, organic solvent, etc.) are mixed with pump oil or sludge collects on the bottom of the pump case, the ultimate pressure cannot recovered by one oil change, the pump oil must be changed several times. If the specified ultimate pressure cannot be

attained by oil change, sludge or other deposit may have collected on the bottom of the pump case. In that event, overhaul is required. Contact with us.

CAUTION

The pump oil might deteriorate in a shorter time depending on the use. It is recommended to replace the first pump oil within ten days after operation start and see how it got dirty to determine the oil replacement cycle.

If the pump breathes in a lot of water or the like, you should replace the oil more frequently. If kept operation without getting rid of breathed water, it would deteriorate lubrication of the oil and accelerate corrosion of the pump inside, then result in a failure. Do not store the pump keeping sucked the water.

You should replace the oil if breathed in the solution to deteriorate lubrication of the oil as it would also cause biting inside. There is a risk if breathed in the solution in operation even you replaced the oil. When using the pump in suction of solvents, it is out of range of warranty.

If the pump breathed in chemical material such as acid, immediately replace the oil as it would cause the rust during the stop in one night to make the system not applicable to operate. When using the pump in suction of chemical material, it is out of range of warranty.

Starting the pump operation might become difficult in winter season or in the cold district. This is the overload phenomenon caused by increased viscosity of the pump oil. To make sure, you should confirm that the capacity of the motor over load protective device conforms to the motor rated value, the pump is not damaged and the cable does not have abnormality. Then, warm up the pump oil or replace the vacuum pump oil with BS046 which having lower viscosity.

CAUTION

When temperature is low and pump does not run, warm the pump oil up to 15°C and turn the pump on and off several times in short intervals.

When the pump stops after run for several seconds, try to move it while putting slow leak in it, there is the thing that the pump can run consecutively.

As the pump warmed, close the slow leak valve and return it to regular running.

6.4 Abnormal noise and vibration check

Checking around the pump

1. Whether bolts and nuts and the like fixing the pump are loose or not.
2. Whether pipes connected to the inlet and outlet are loose or not.
3. Check and ensure that there is no leakage from the piping and valves. Please refer to the table 7 "Trouble Check List" to check the pump.

6.5 Checking the metal mesh at the inlet port

The suction inlet might be clogged by the dust contained in the gas breathed in from the vacuum chamber and thus the pump performance might be impaired. If the metal mesh is dirty, please wash it. If it is damaged, replace it.

There will be welding spatter drops off in the pipe particularly at the beginning of the system start. Be fully caution.

6.6 Pump stopping and storage

CAUTION

Ensure first close the vacuum valve then open the leak valve last stop the pump. If failed in following this procedure, the pump cylinder will fill with the oil in several minutes, which might make difficult to restart operation or pump damaged.

Further the oil might accidentally flow back to the vacuum tank.

If failed in closing the vacuum valve, the vacuum might leak from the exhaust side through the pump unit.

1. When operation finished, first close the vacuum valve which is on the inlet, then stop the pump.
2. After pump stopped, open the vent valve to restore pump pressure to atmospheric pressure.
3. Ambient temperature, humidity and height for storage: -10 to 50°C, less than 95%RH (no freeze, no condensation), lower than el. 1000m. It shall be in house, no direct sun beam. The pump shall not be stacked, inverted or rollover.
4. There shall be no corrosive or explosive gas around the pump, and keep clean to prevent debris into the pump. If the pump does not operate for a long time, seal the inlet and outlet port to prevent dust, dirt into the pump.
5. If the pump does not operate for a long time, condensable gas will be adsorbed in the pump cylinder or sealing parts. You can extend pumping time to exhaust the gas before the pump returning to regular running.
6. Long term storage of the vacuum pump without operation might possibly cause trouble in operation because of rust. If you kept the pump long time without operating it, ask a closest service center or contact with us for the check.

7 Disposal

Make sure to keep in compliance with the laws and regulations established by the local governments to dispose the vacuum pump. You should ask the dedicated disposal agency for the disposal particularly if the pump has exhausted any toxic gas. For the disposal of pump oil, follow the instructions in "Material Safety Data Sheet".

Note that you are requested to bear the cost and charges relating to the disposal.

8 Warranty Clauses

We warrant each product sold after strict inspection and to be free from defects in manufacture or other failure caused by our faults. Please contact our sales departments, distributors or agents for free repair or replacement.

Warrantable items

Oil sealed rotary vacuum pump BSV10, BSV16, BSV24, BSV30, BSV40, BSV60, BSV90.

Warranty period

Domestic purchase: one year after the shipping date from our factory.

Overseas purchase: one year after the date of B/L signed.

Warranty scope

Products not meet the standard specification although the product is used under the service conditions described in this document such as temperature range and power etc.

Solutions

1. Domestic purchase

Send a replacement or please go to near service center for repair. If you need field service, please contact our sales department or agents.

2. Overseas purchase

Send a replacement. Return charge shall be paid by buyer.

9 Disclaimer Clauses

1. Products which extend warranty period.
2. Failure and defects caused by forced majority, such as floods, fire, typhoon, lightning and earthquake etc.
3. Failure and defects due to misuse or abuse.
4. Products which had been repaired, disassembled or reconstructed without our approval.
5. Failure and defects under unusual conditions (strong electromagnetic, radioactive environment, high temperature, high moisture, flammable gas, corrosive gases, dust etc.)
6. Failure and defects caused by noise.
7. Consumables.

Others

1. Any clauses in contracts besides this warranty or in relative qualification memorandum will be valid.
2. Buyer shall inform our company when the pump is exported out of Chinese mainland. In the meantime buyer shall take necessary procedures according to Foreign Exchange and Foreign Trade Law.
3. The contents of this document are subject to change without notice in the future.

10 Main Replaceable Parts

Table 3 Main replaceable parts list for BSV10/BSV16

Location	Description	Specifications	Material	Qty
Coupling	Coupling Spider	-----	NBR	1
Shaft	Oil seal	17X30X7	FKM	2
	Oil seal	19X35X7	FKM	1
	Oil seal	17X40X8	FKM	1
Exhaust valve	Rubber pad	For BSV10	FKM	2
	Rubber pad	For BSV16	FKM	4
Cylinder	O-ring	S8, JIS	FKM	4
	O-ring	S16, JIS	NBR	2
	O-ring	S30, JIS	NBR	2
	O-ring	S44, JIS	NBR	1
	O-ring	S70, JIS	NBR	3
	O-ring	G55, JIS	NBR	1
Plug	O-ring	A-261, AS568	NBR	1
	O-ring	P18, JIS	NBR	1
Inlet port	O-ring	P35, JIS	NBR	1
Outlet port	O-ring	P31, JIS	NBR	1
Oil level gauge	O-ring	45X3, M	NBR	1

Table 4 Main replaceable parts list for BSV24

Location	Description	Specifications	Material	Qty
Coupling	Coupling Spider	-----	NBR	1
Shaft	Oil seal	15X30X7	FKM	1
	Oil seal	17X30X7	FKM	2
	Oil seal	17X40X8	FKM	1
Exhaust valve	Rubber pad	-----	FKM	4
Cylinder	O-ring	S5, JIS	FKM	4
	O-ring	S12, JIS	NBR	1
	O-ring	S16, JIS	NBR	2
	O-ring	S24, JIS	NBR	2
	O-ring	S44, JIS	NBR	1
	O-ring	S85, JIS	NBR	3
	O-ring	G55, JIS	NBR	1
Plug	O-ring	195X3.55, ISO	NBR	1
	O-ring	P18, JIS	NBR	1
Inlet port	O-ring	P35, JIS	NBR	1
Outlet port	O-ring	P31, JIS	NBR	1
Oil level gauge	O-ring	45X3, M	NBR	1

Table 5 Main replaceable parts list for BSV30/BSV40

Location	Description	Specifications	Material	Qty
Coupling	Coupling Spider	-----	NBR	1
Shaft	Oil seal	TCV244008	NBR	3
Exhaust valve	First exhaust valve plate	-----	SUS	1
	Second exhaust valve plate	-----	SUS	1
Cylinder	O-ring	S8, JIS	FKM	4
	O-ring	S18, JIS	NBR	1
	O-ring	S70, JIS	NBR	1
	O-ring	S105, JIS	NBR	3
	O-ring	P40, JIS	NBR	1
	O-ring	A-267, AS568	NBR	1
Plug	O-ring	P18, JIS	NBR	1
	O-ring	P36, JIS	NBR	1
Inlet port	O-ring	V55, JIS	NBR	1
Outlet port	O-ring	P46, JIS	NBR	1
Oil level gauge	O-ring	77.5X3.55, C	FKM	1

Table 6 Main replaceable parts list for BSV60/BSV90

Location	Description	Specifications	Material	Qty
Coupling	Coupling Spider	-----	NBR	1
Shaft	Oil seal	TCV244008	NBR	3
Exhaust valve	First exhaust valve plate	-----	SUS	2/3
	Second exhaust valve plate	-----	SUS	1
Cylinder	O-ring	S8, JIS	FKM	4
	O-ring	S18, JIS	NBR	1
	O-ring	S70, JIS	NBR	1
	O-ring	S120, JIS	NBR	3
	O-ring	P48, JIS	NBR	1
	O-ring	A-274, AS568	NBR	1
Plug	O-ring	P18, JIS	NBR	1
	O-ring	P36, JIS	NBR	2/3
Inlet port	O-ring	V70, JIS	NBR	1
Outlet port	O-ring	P46, JIS	NBR	1
Oil level gauge	O-ring	77.5X3.55, C	FKM	1

11 Trouble Check List

Table 7 Trouble Check List

Trouble	Causes	Processing method
The pump does not run	Motor connection is wrong	Check the connection
	The motor malfunction	Replace the motor
	The pump is stuck	Conduct the overhaul
	Oil viscosity got higher	Replace the oil
	Temperature is low	Warm up or replace the pump oil
	Exhaust filter or exhaust pipe is clogged	Clean exhaust filter or exhaust pipe
	Problem with power supply voltage	Set the power supply voltage to within 10%
	Parts inside the pump are damaged	Overhaul(replace the damaged part)
	Press the reset button	Press the reset button
Pressure does not come down	Gas ballast valve is open	Close gas ballast valve
	The pipe connected to the inlet port is thin or connection distance is long	Connect a pipe wider than inlet diameter and shorten the distance between the vacuum chamber
	Leakage occurs from the pipe connected to the pump	Locate the leakage with a leak age detector and stop the leak age
	Metal mesh at the inlet port is clogged	Remove the pipe above the inlet and clean the mesh
	Specified oil is not being used	Overhaul the pump and replace the oil specified by us
	The oil is deteriorated or not supplied to the specified volume	Replace the oil or add the oil to the specified volume
	Oil does not circulate	Overhaul
	a) Oil hole of the cover the like is clogged	a) Clean the oil hole
	b) Oil distributor valve has a trouble	b) Check and repair the oil distributor valve
	Pumping speed is too small to the volume of the chamber	Select another pump
	The pressure measurement method is not correct	Measure the pressure correctly
	The vacuum gauge is not suitable	Measure with a calibrated vacuum gauge suitable for the pressure range
Pump surface temperature is abnormally high	Area around the pump is enclosed	Make the ventilation available
	The temperature of the evacuated gas is high	Mount cooling equipment such as a gas cooler at the inlet side
	The environment temperature is high	Use pump in environment with air conditioner

	Keeping continuous operation under high suction pressure	Pump surface temperature reaches 100°C on continuous operation under high suction pressure, no problem
	Oil is under the MIN line of the oil	Add the specified amount of oil
	Oil does not circulate, or the oil hole of the cover is clogged	Overhaul and clean the oil hole
Abnormal sound is generated	Oil is not filled. Oil is under the MIN line of the oil level	Overhaul (replace the cylinder, rotor and cover)
	Oil does not circulate	Overhaul
	a) The oil hole of the cover is clogged	a) Clean the oil hole
	b) Oil distributor valve has a trouble	b) Check and repair the oil distributor valve
	Cooling fan is loose	Check the cooling fan mounting
	Rattling sounds on starting or stopping the pump	It's a phenomenon caused by vanes that temporarily make irregular motions, not a particular problem
	Vanes are damaged	Replace the vane
	Motor rotation direction is reverse	Do the connection again to correct rotation direction.
	Panel screw is loose	Tighten the screw
	Coupling spider is damaged	Replace the coupling spider
	Foreign matter has entered the pump	Disassemble and clean the pump to eliminate foreign matter
	Parts inside the pump are damaged	Overhaul (replace the damaged parts)
Lot of oil splashed out of the outlet port	Pump oil exceeds the specified amount	Drain the oil until it gets the specified amount
	Continuous operation is performed at a high evacuation pressure	install an oil mist trap at the outlet side
	Oil mist trap is clogged	Clean or replace the oil mist trap
	Exhaust valve plate is damaged	Replace the exhaust valve plate
The oil leaks outside the pump	Deterioration of the O-ring and oil seal of the case and cover	Check and replace the O-ring and oil seal
	Continuous operation is performed at a high evacuation pressure	Please select the heat-resisting O-ring and oil seal
	The drain port is loose, the gasket is damaged.	Tighten the drain port, replace the gasket

Note: Please refer to the related content in this manual to operate.

Check Sheet for Repair

Model		Serial		Purchase Date	
Customers					
Address					
Person in charge			Tel No.		
<p>1 Request item</p> <p><input type="checkbox"/> Scheduled inspection repairing</p> <p><input type="checkbox"/> Trouble</p> <p>Condition: <input type="checkbox"/> Ultimate pressure <input type="checkbox"/> Unusual sound <input type="checkbox"/> Irregular action</p> <p style="padding-left: 40px;"><input type="checkbox"/> Oil leak outside the pump <input type="checkbox"/> Others</p> <p>Description of trouble: _____</p> <p>_____</p> <p><input type="checkbox"/> Others: _____</p>					
<p>2 Service condition</p> <p>✓ Whether the pump has been used: <input type="checkbox"/> Yes <input type="checkbox"/> No</p> <p style="padding-left: 40px;">Operational elapsed time: about _____</p> <p><input type="checkbox"/> 24hr continuous operation <input type="checkbox"/> Intermittent operation</p> <p>✓ Whether exposure to pollutants: <input type="checkbox"/> Yes <input type="checkbox"/> No</p> <p style="padding-left: 40px;">Name and Chemical formula pollutants: _____</p> <p style="padding-left: 40px;">Nature and character of pollutants: _____</p> <p style="padding-left: 40px;">Cleaning solvents and methods of pollutants: _____</p>					
<p>3 Details of the request</p> <p><input type="checkbox"/> Warranty period <input type="checkbox"/> Repair quote please <input type="checkbox"/> Others: _____</p>					
<p>4 Others: _____</p>					
Signature			Date		

Notice:

- 1 Copy this sheet use as repaired.
- 2 Your request for repair and inspection may be refused if this sheet is not included with the pump.
- 3 Information of hazardous gas in this sheet must be correct and sufficient.



NINGBO BAOSI ENERGY EQUIPMENT CO.,LTD.

Add:No.55,Juchao Rd.,Jiangkou District,Fenghua City,
Zhejiang Province,PRC

P.C: 315500

Tel: 0086-574-88569588 59516555

Fax: 0086-574-88569596

E-mail:bsc@cnbaosi.com

Http://www.cnbaosi.com