

Chiller Controller

Manufacturer Instruction Manual

Please read the in manual carefully before installing the controller!

Aguest 30, 2021

Software Version : X1.GW532A.TY.F01M V100B9

All rights reserved. Any reproduction of the manual will be prosecuted.

Table of contents

1 Instructions	1
2 Specifications	1
3 Panel Diagram	1
4 First Power-on	1
5 Common Screens	2
5.1 Main Screen	2
5.2 Alarm Screen	2
6 Common Operation	2
6.1 Quick Modification of Setting Temperature	2
6.2 Query/Reset Fault	2
7 Function Menu	3
8 Parameter Operation	4
9 User Parameters Table	4
10 Manufacturer Menu	5
10.1 Procedures of Entering Manufacturer Menu	5
10.2 Details of Manufacturer Menu	5
10.3 Manufacturer Debugging	5
10.4 Configuration Guide	6
11 Fault List	7
12 Control	10
12.1 Logic of compressor	10
12.2 Logic of pump freeze protection	10
13 Manufacturer Parameters Table	10
14 Electrical Connection Diagram	14
15 Installation Dimensions	14

1 Instructions

Dear Customer:

Thank you for choosing our products!

For your convenience, please read the instructions carefully and follow the steps of the Manual.

2 Specifications

No.	Specification Parameter	Description	No.	Specification Parameter	Description
1	Rated input voltage	220-250VAC 50/60HZ	6	Switch Output	5 relays 250VAC 2A
2	Temperature Range	-40~100°C	7	Relay load type	D01:annunciator D02-D05: contactor or valve
3	Measurement Accuracy	0.1°C@25°C	8	Switch Input	12 passive signal inputs
4	Working Environment	-10°C~60°C, ≤85%RH non-condensation	9	Analog Input	1 NTC temperature sensor
5	Storage Environment	-20°C~70°C, ≤85%RH non-condensation	10	Current Input	4 ways of current (0.3~35A)

3 Panel Diagram

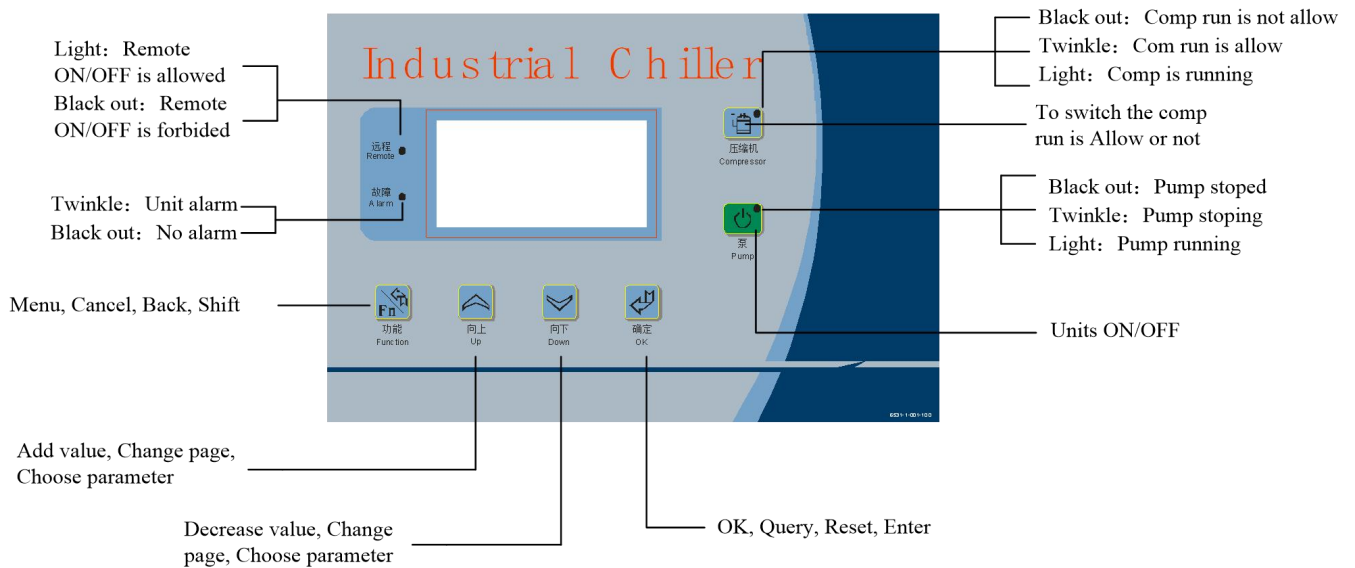

4 First Power-on

The controller needs to be configured when powered on for the first time. Please refer to 10.4 Configuration guide for specific operation.

5 Common Screens

Commonly used screens include the main screen and the alarm screen.

5.1 Main Screen

The system will enter the main screen after countdown, which displays as follows:

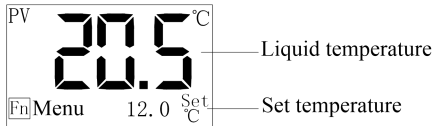

Press + for 3 seconds on the main screen can change the language quickly.

5.2 Alarm Screen

In case of unit failure, the alarm screen is as follows:

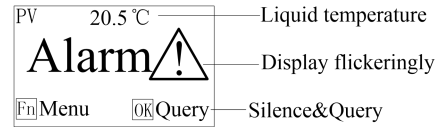

Press + during down count and enter Language screen, press or to change current Language, press to quit without saving, press to save and quit.

6 Common Operation

6.1 Quick Modification of Setting Temperature

If the user parameter [Lock T.set] is set to "No", the setting temperature can be modified directly in the main screen, with operation details as follows:

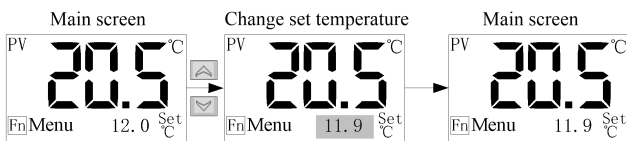

Note: the setting temperature can also be modified in the user parameters.

6.2 Query/Reset Fault

In case of fault, the alarm screen will automatically pop up. The operation details of query and reset faults are as follows:

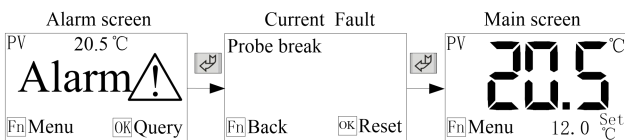

7 Function Menu

Press the button  on the main screen to enter the Function Menu, which includes five items as the table below:

No.	Menu Item	Funtion	Remark
1	User Settings	To display user parameters	For number of user parameters and their implications, please refer to: 9 User Parameters Table.
2	Unit Status	To display the current operating status of the unit	Current value is not displayed when current module is not used.
3	History List	Allowing the query of the last 10 faults	Press  for 2s to clear the fault history.
4	Comp run time	To display the cumulative operation time of the compressor	
5	Version	To check the current software version	

8 Parameter Operation

For the modification operation of parameter value, the user's modification of setting temperature will be described as an example.

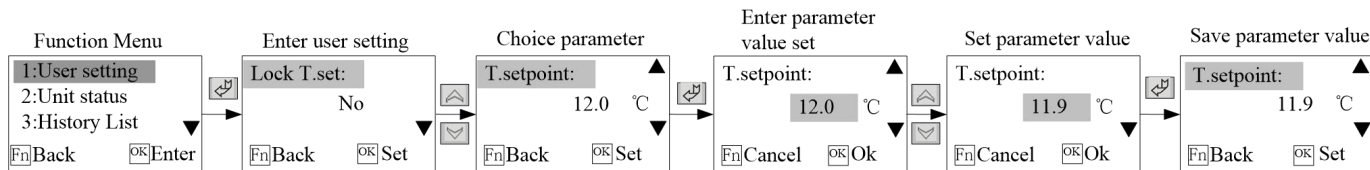



9 User Parameters Table

The implication of each parameter in the user parameters is listed in the following table:

No.	Parameter Name	Factory Default	Setting Range	Remark
1	Lock T.set	No	Yes ~ No	Yes: the set temperature can not be modified on the main screen when locked. No: the set temperature can be modified on the main screen.
2	T.setpoint	12.0°C	[T.setpoint min] ~ [T.setpoint max]	Setting range is limited by the manufacturer parameters [T.setpoint max], [T.setpoint min]. (When the [TEMP Unit] is set "Fahrenheit", the parameter is not displayed.)
3	T.setpoint	53.6 °F	[T.setpoint min] ~ [T.setpoint max]	Setting range is limited by the manufacturer parameters [T.setpoint max], [T.setpoint min]. (When the [TEMP Unit] is set "Celsius", the parameter is not displayed.)
4	TEMP Unit	Celsius	Celsius; Fahrenheit	
5	Contrast	32	20~44	Adjust the LCD contrast
6	On/Off type	Local	Local / Local + Remote / Remote	Local: the unit can only start and stop locally. Local + Remote: the start and stop of the unit can be controlled both locally and remotely. Remote: the unit can only start and stop remotely.
7	Backlight On	0	0~255 minute(s)	0: backlight is not turned off.
8	Language	中文	中文~English	Select the display language.
9	Comp Select	Two Comp	1#Comp/2#Comp/Two Comp	Select the Comp to run. if select one comp the other does not work. The parameter is not listed for the single comp machine.

10 Manufacturer Menu

Press  +  in the main screen to enter the Enter Password screen and enter the correct manufacturer password (default 4561, which is recommended to change). Then enter the Manufacturer Function Menu, which includes five items.

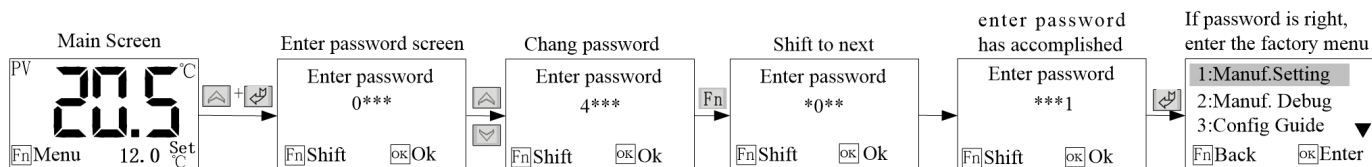

10.1 Procedures of Entering Manufacturer Menu



10.2 Details of Manufacturer Menu

The details and function of manufacturer menu are shown in the following table:

No.	Parameter Item	Function	Remark s
1	Manuf. setting	To set the parameters commonly used by the manufacturer	Refer to 13 Manufacture Parameters for specific parameters.
2	Manuf. debug	To debug the abnormal operation of each electrical part of the unit	Not available during the unit operation.
3	Config guide	Commonly used parameters of config the unit	Not available during the unit operation. The screen will pop up when powered on for the first time.
4	Initialize	For initialize all parameters of the machine.	Refer to 10.5 Manufacture Parameters for the initial values of the parameters.
5	Password Set	To set the password to enter manufacturer menu.	The default value is 4561, which is recommended to change.

Note: Press  +  in the manufacturer menu for 2 seconds can reset the accumulative operation time of the compressor.

10.3 Manufacturer Debugging

Manufacturer debugging is mainly used to test whether the operation of each electrical part of the unit is normal, which is not available when the unit is under operation.

Method: to determine whether the unit is normal by testing three-phase power input, seven alarm inputs (10 alarm inputs for two compressors) and 5 relay outputs. For alarm input, it only displays the test result. If the result is normal the wiring is good and parameter settings are correct; if it alarms, with flashing display of alarm characters, then make sure whether the external wiring is good and the parameter settings are consistent.

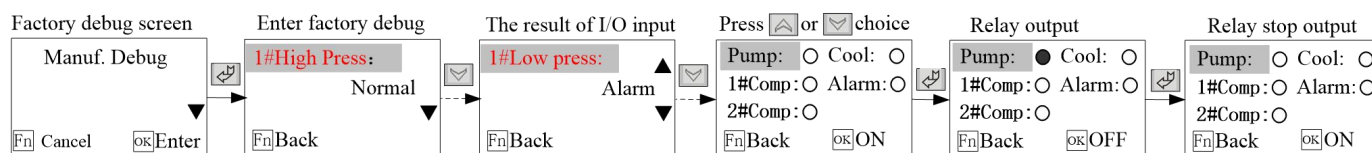

10.4 Configuration Guide

Configure the common parameters of the machine. For the number of parameters of configuration guide and the significance, please refer to 13 Manufacturer Parameters Table. Access is not available during the unit operation.

Refer to the Parameter Operation for specific configuration method. The Configuration guide screen will pop up when powered on for the first time. And if you click “Cancel” operation without configuring at this point, the Configuration guide screen will still pop up when powered on next time. Once you have entered the Configuration guide, the Configuration guide screen will not pop up when powered on and you can only enter the Configuration guide through the Manufacturer Menu.

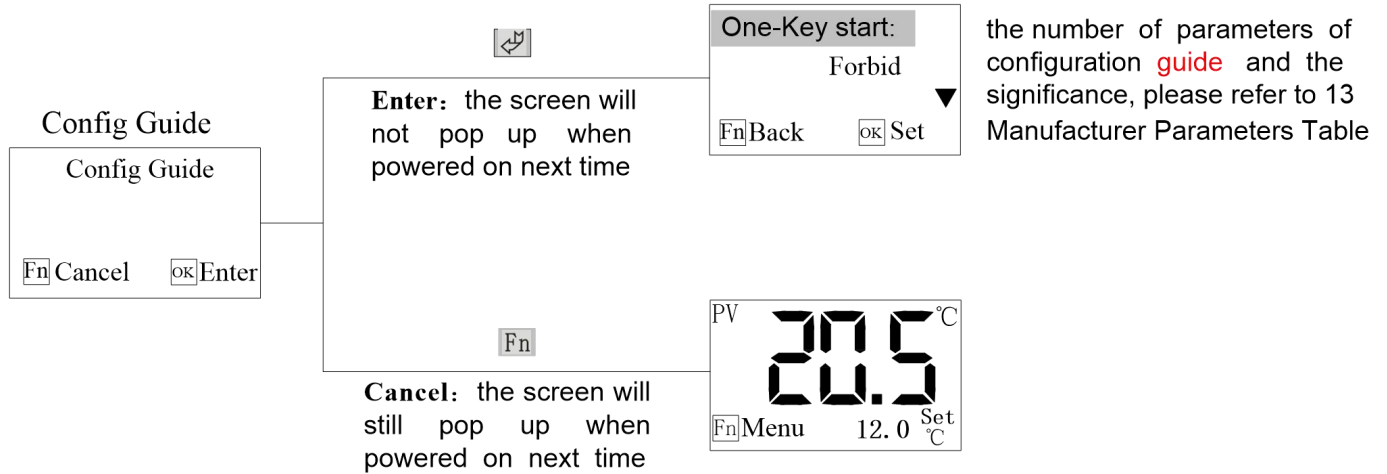

11 Fault List

Fault	Description	Test Conditions	Troubleshooting	Solution
1#Comp.P high	High pressure of compressor1	Test when the compressor button has pressed	Stop compressor1 only without affect other equipments to work. [Note1]	Check if the input is consistent with the switch setting. Check if the input is consistent with the switch setting. Check if the rated current of compressor1 is input is reasonable. Check if the measure tool of the compressor1 current is connect. Check if the input is consistent with the switch setting.
1#Comp.P low	Low pressure of compressor1	If the [LP detect dly] is 0, test when the compressor button has pressed; If the [LP detect dly] is not 0, then compressor1 runs the test.		
1#Comp overload	The compressor1 overload	Compressor1 runs the test.		
1#Comp.I high	The current of compressor1 is too high			
1#Comp.I low	The current of compressor1 is too low			
1#T.Vent high	The vent temperature of compressor1 is too high			
2#Comp.P high	High pressure of compressor2	Test when the compressor button has pressed	Stop compressor2 only without affect other equipments to work. [Note2]	Check if the input is consistent with the switch setting. Check if the input is consistent with the switch setting. Check if the rated current of compressor2 is input is reasonable. Check if the measure tool of the compressor2 current is connect. Check if the input is consistent with the switch setting.
2#Comp.P low	Low pressure of compressor2	If the [LP detect dly] is 0, test when the compressor button has pressed; If the [LP detect dly] is not 0, then compressor2 runs the test.		
2#Comp overload	The compressor2 overload	Compressor2 runs the test.		
2#Comp.I high	The current of compressor2 is too high			
2#Comp.I low	The current of compressor2 is too low			
2#T.Vent high	The vent temperature of compressor2 is too high			
Temp.low AL	The liquid temperature is too low	Test after cold pump starts	Stop the compressor and delay to stop the cool pump, and do	Check if the Liquid temperature is lower than the set temperature of

			not stop the cold pump.	Liquid protection.
T.high warn	The liquid temperature is higher than the warn value.		Alarm only without affect other equipments to work.	Check if the Liquid temperature is higher than the set temperature of Liquid warn.
Temp.high AL	The liquid temperature is too high		If the [Temp.high AL] is set "Pump keep", Stop the compressor and delay to stop the cool pump, and do not stop the cold pump; If the [Temp.high AL] is set "Pump stop", Stop the unit in case of fault.	Check if the Liquid temperature is higher than the set temperature of Liquid protection.
Anti-freez.AL	Antifreeze alarm			Check if the antifreeze input is consistent with the switch setting.
Probe break	The liquid temperature sensor is break	Power on to test	Stop all the compressor and cool pump, and do not stop the cold pump.	Check if the temperature probe is in proper contact.
Probe short	The liquid temperature sensor is short			
cool fan overld [Note3]	The cool pump or fan overload			Check if the fan1 overload input is consistent with the switch setting.
Cool.I high AL	The current of cool pump or Fan is too high	Test after Cool pump starts	Stop compressor1 and cool pump or fan only	Check if the rated current of cool is input is reasonable.
Cool.I low AL	The current of cool pump or Fan is too low			Check if the measure tool of the cool current is connect.
Cool W.flow AL	Lack of cool water flow	Test after the cool pump starts for [Cool on delay] time	Stop compressor1 and cool pump or fan only	Check if the cool water flow input is consistent with the switch setting.
Cold W.flow AL	Lack of cold water flow	Test after the cold pump starts for [Pump on delay] time	If the [Lack of water] is set "Pump keep", Stop compressor and cool pump in case of fault. If the [Lack of water] is set "Pump stop", Stop the unit in case of fault.	Check if the cold water flow input is consistent with the switch setting.
Cold Pump	The cold pump overload	Test after cold pump starts	Stop the unit	Check if the cold pump overload

Overld [Note3]				input is consistent with the switch setting.
Pump.I high AL	The current of cold pump is too high			Check if the rated current of cold is input is reasonable.
Pump.I low AL	The current of cold pump is too low			Check if the measure tool of the cold current is connect.
Phase AL	The three-phase power input is alarm	Power on to test	Stop the unit	Check if there is default phase or anti-phase in the three-phase power input and if the switch is correct.
Water lv. AL	The water level is low	Power on to test	If the [Low water lv.] is set "Pump keep", Stop compressor and cool pump in case of fault. If the [Low water lv.] is set "Pump stop", Stop the unit in case of fault.	Check if the water level input is consistent with the switch setting.
Need Maintain	The total time of compressor run over the allow value	Test after cold pump starts	The unit cannot start once stops (the accumulative operation time of compressor exceeds the set value).	
1#Comp Oil Low	The comp oil level is low	Compressor1 runs the test.	Stop the compressor and delay to stop the cool pump, and do not stop the cold pump.	Check if the comp oil level input is consistent with the switch setting.
2#Comp Oil Low				

[Note 1]: In case of "1#Comp.P low " fault, if [LP stop pump] is not zero, the troubleshooting program is: to immediately stop all compressors and cool pump, delay the [LP stop pump] and stop the cold pump. If [LP stop pump] is zero, then the troubleshooting program is: to only stop compressor1 without affect other equipments to work.

[Note 2]: In case of "2#Comp.P low " fault, if [LP stop pump] is not zero, the troubleshooting program is: to immediately stop all compressors and cool pump, delay the [LP stop pump] and stop the cold pump. If [LP stop pump] is zero, then the troubleshooting program is: to only stop compressor2 without affect other equipments to work.

[Note3]:

[Machine type]	the screen real display when Cold Pump overload	the screen real display when Cool Pump overload
AIR-WATER	Cold Pump Overld	Cool Fan Overld
W-W SYS.	Cold Pump Overld	Cool Pump Overld
AIR-AIR	Cold Fan Overld	Cool Fan Overld
WATER-AIR	Cold Fan Overld	Cool Pump Overld

		stop	Pump keep	flow fault; Pump keep: do not stop the cold pump in case of cold water flow fault.
	*Current detect	Use	Forbid ~ Use	Use: there is a current detection module; Forbid: no current detection module
	*1#Comp.l rating	0.3A	0~35.0A	0A: do not detect the current fault. When [Current detect] is set "Forbid", those parameter is not displayed. (if the rating current of Comp or Pump is lower 1A, when using please winding two or three laps on the sensor)
	*2#Comp.l rating	0.3A	0~35.0A	
	*Pump. I rating	0.3A	0~35.0A	
	*Cool. I rating	0.3A	0~35.0A	
	*Phase monitor	On_board	On_board; Forbid; IO_input	Onboard: use the controller's own three-phase power protection; Switch input: use an external three-phase power protection. (The external three-phase power protection can only be used when [DI9 function] is set "Phase switch" .) Forbid: do not use three-phase power detection function.
	DI1 input opt	Cool overload	Cool overload; Anti-freezing	Selection of switch DI1 input function
	*Comp number	2	1~2	Selection of the number of compressor
	*Machine type	AIR-WATER	AIR-WATER; W-W SYS.; AIR-AIR; WATER-AIR	AIR-WATER. fan-cooled water chiller, W-W SYS. :water-cooled water chiller, AIR-AIR : fan-cooled fan cooler WATER-AIR : water-cooled fan cooler
	*Lang switch	Use	Forbid ~ Use	Use: Allows users to switch between English and Chinese. Forbid: Forbid users to switch between English and Chinese.
	Temp.high AL	Pump keep	Pump stop ~ Pump keep	Pump stop: stop the cold pump in case of Temp.high fault; Pump keep: do not stop the cold pump in case of Temp.high fault.
	DI2 function	Remote	Remote; 1#Comp Oil LVL	Remote:DI2 input for remote switch 1#Comp Oil LVL: DI2 input for 1#comp oil level detection
	DO1 function	Alarm signal	Alarm signal; Run signal	If [DO1 function] is "Alarm signal" [Alarm type] is N.O: the alarm relay is ON in case of faults; [Alarm type] is N.C: the alarm relay is OFF in case of faults. If [DO1 function] is "Run signal" [Alarm type] is N.O: the alarm relay is OFF when the unit is normal running; [Alarm type] is N.C: the alarm relay is ON when the unit is normal running.
Temp. Setting	Load offset	1.0°C	0~10.0°C	Temperature deviation of load the compressor
	Load offset	1.8°F	0~18.0°F	Fahrenheit °F
	Unload offset	1.0°C	0~10.0°C	Temperature deviation of unload the compressor
	Unload offset	1.8°F	0~18.0°F	Fahrenheit °F
	T.setpoint max	30.0°C	-38.0~99.9°C	To limit the temperature of user set.
	T.setpoint max	86.0°F	-36.4~211.8°F	
	T.setpoint min	5.0°C	-38.0~99.9°C	
	T.setpoint min	41.0°F	-36.4~211.8°F	Fahrenheit °F
	T.bias	0.0°C	-9.9~9.9°C	Compensation for the liquid temperature
T.bias	0.0°F	-17.8~17.8	Fahrenheit °F	

	T.low protect	4.0℃	-40.0~99.9℃	Fault of "Temp.low AL" warning is reported when the liquid temperature is lower than the set value.
	T.low protect	39.2°F	-40.0~211.8°F	Fahrenheit °F
	T.high warn	50.0℃	0~99.9℃	Fault of "Temp.high warn" warning is reported when the liquid temperature is higher than the set value.
	T.high warn	122.0°F	32.0~211.8°F	Fahrenheit °F
	T.high alarm	60.0℃	0~99.9℃	Fault of "Temp.high AL" warning is reported when the liquid temperature is higher than the set value. And Stop the compressor and delay to stop the cool pump.
	T.high alarm	140.0°F	32.0~211.8°F	Fahrenheit °F
	T.high reset	5.0℃	0~99.9℃	If liquid temperature<[T.high alarm]-[T.high reset], manual reset of "Temp.high AL" fault is allowed; If liquid temperature<[T.high warn]-[T.high reset], the "Temp.high warn" fault is automatically reset;
	T.high reset	9.0°F	0~179.8°F	Fahrenheit °F
	T.freeze prot	forbid	forbid~15.0℃	No such function when set to forbid.
	T.freeze prot	forbid	forbid~59.0°F	No such function when set to forbid(32.0°F).
Time Setting	Pump on delay	10 S	1~255 S	Delay after cold pump startup.
	Cool on delay	10 S	1~255 S	Delay after cool pump startup.
	Capacity ctrl.	5 S	0~255 S	Control the compressor ON/OFF every [Capacity ctrl.] interval time; For double-compressor control, if the conditions of two compressors ON are satisfied, then one of the compressors ON and the other after the time of [Capacity ctrl.].
	Comp protect	60 S	0~255 S	To avoid frequent ON/OFF the compressor, the interval between the start of two compressors must be greater than the set value.
	Input stable	2 S	0~255 S	The time General fault stable.
	W.flow stab.	5 S	0~255 S	It is considered to be valid only when the water flow alarm continue for the time.
	LP detect dly	60 S	0~255 S	Compressor low-pressure fault input is allowed only when the compressor has run for the set time.
	LP stable	5 S	0~255 S	Low-pressure fault stable time
	LP stop pump	0 S	0~300 S	0: the parameter has no effect . Non-0: in case of low pressure fault of the compressor, immediately stop all compressors and cool pump, delay the [LP stop pump] and stop the cold pump.
	Comp operation	0 H	0~9999 H	0: this parameter has no effect. Non-0: the compressor cannot start when the accumulative operation time is greater than the set value.
	Comp shift	0 Min	0~255 H	0: the parameter has no effect ; Non-0: a compressor will automatically switch to another after it has run continuously for that time.
	1#Comp.l avoid	2 S	1~255 S	The current fault of 1#compressor can only be detected after 1# compressor has started for the set time. (When the [Current detect] is set "forbid", the parameter is not displayed.)
	2#Comp.l avoid	2 S	1~255 S	The current fault of 2#compressor can only be detected after 2# compressor has started for the set time. (When the [Current detect] is set "forbid", the parameter is not displayed.)
	Pump. l avoid	2 S	1~255 S	The current fault of cold pump can only be detected after it has started for the set time. (When the [Current detect] is set "forbid", the parameter is not displayed.)

	Cool. l avoid	2 S	1~255 S	The current fault of cool pump can only be detected after it has started for the set time. (When the [Current detect] is set "forbid", the parameter is not displayed.)
	Comp Oil dly	5 S	1~255 S	1#Comp/2#comp oil low stable time
Input Setting	*Freez overload	N.O	N.O ~ N.C	Selection of switch input mode N.O: switch off with no fault; N.C: the switch is closed with no fault.
	*Cold W.flow	N.C	N.O ~ N.C	
	*W.level switch	N.C	N.O ~ N.C	When [DI5 fuction] is " Vent1 temp", it is the place for N.O and N.C settings of vent1 temperature detection.
	*Comp overload	N.O	N.O ~ N.C	Selection of switch input mode N.O: switch off with no fault; N.C: the switch is closed with no fault.
	*Low pressure	N.C	N.O ~ N.C	
	*High pressure	N.O	N.O ~ N.C	
	*Phase error	N.O	N.O ~ N.C	When [DI9 fuction] is " Cool W.flow", it is the place for N.O and N.C settings of cool water flow switch. When [DI9 fuction] is "Vent1 temperature", it is the place for N.O and N.C settings of vent1 temperature detection.
	*Cool overload	N.C	N.O ~ N.C	When [DI1 input opt] is " Anti-freezing", it is the place for N.O and N.C settings of antifreezing switch.
Comp Oil switch	N.C	N.O ~ N.C	1#Comp/2#comp oil low N.O: switch off with no fault; N.C: the switch is closed with no fault.	

[Note]: remote switch, if the remote control is used, the unit will start up when remote switch input is closed and stop when remote switch input is disconnected.

14 Electrical Connection Diagram

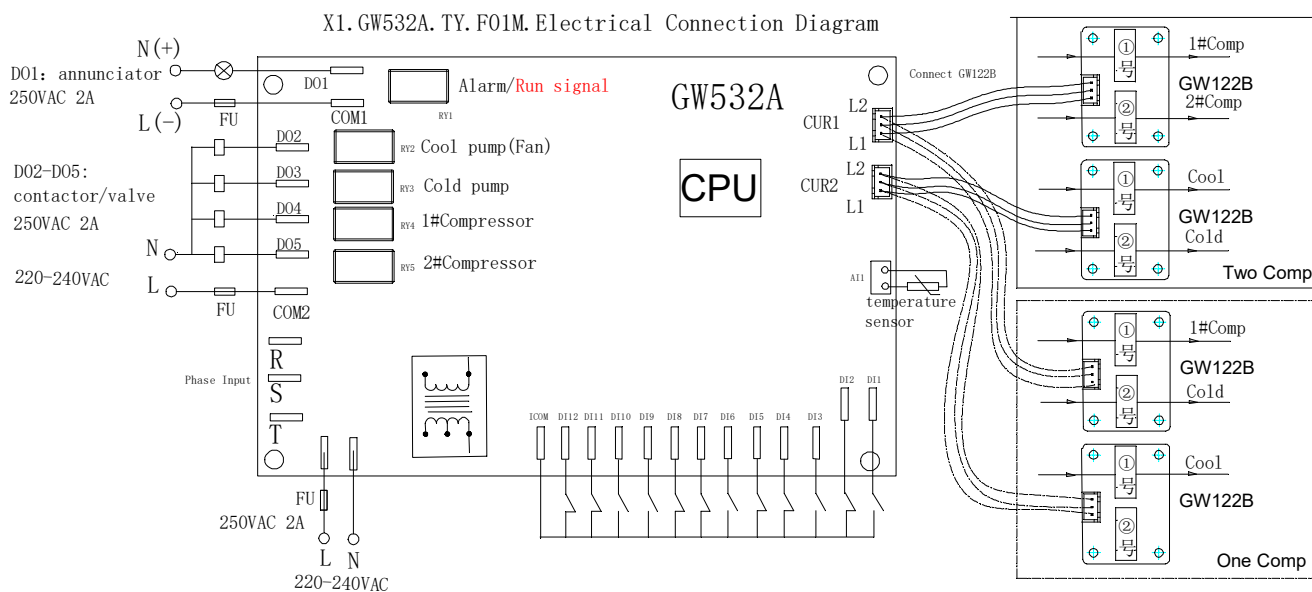

- | | |
|---|---|
| DI1: Cool overload/Antifreezing switch | DI7: Low pressure of 1#compressor |
| DI2: Remote switch | DI8: High pressure of 1#compressor |
| DI3: Cold Pump overload | DI9: Cool flow switch/Vent2 temprature/Phase switch |
| DI4: Cold Water flow switch | DI10: 2#Compressor overload |
| DI5: Water level switch/Vent1 temperature | DI11: Low pressure of 2#compressor |
| DI6: 1#Compressor overload | DI12: High pressure of 2#compressor |

15 Installation Dimensions

