

TRIVAC[®] L

D 40 L / D 63 L / D 90 L

Rotary Vane Vacuum Pump

Operating instructions 300956027_002_A0

Draft

Part Numbers

1019040V00/1019040V01/
1019040V02/1019040V03

1019063V00/1019063V01/
1019063V02/1019063V03

1019090V00/1019090V01/
1019090V02/1019090V03

and their variants.

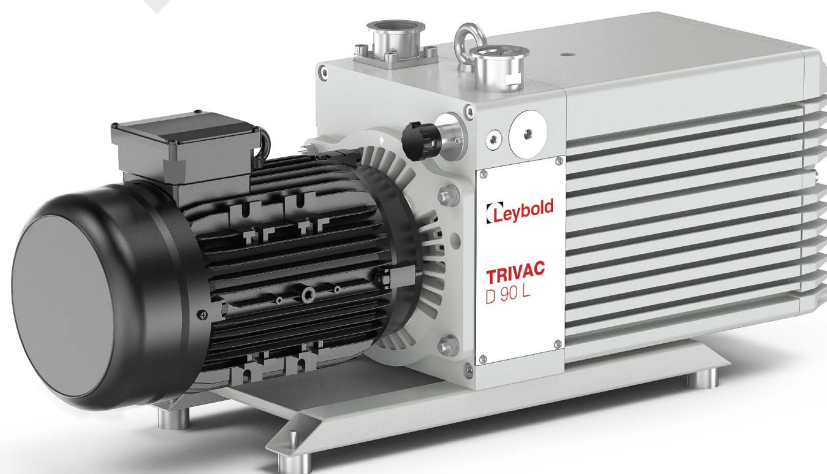

Copyright notice

©Leybold GmbH. All rights reserved.

Trademark credit

Leybold and the Leybold logo are trademarks of Leybold GmbH, Bonner Strasse 498, D-50968 Cologne.

Disclaimer

The content of this manual may change from time to time without notice. We accept no liability for any errors that may appear in this manual nor do we make any expressed or implied warranties regarding the content. As far as practical we have ensured that the products have been designed and constructed to be safe and without risks when properly installed and used in accordance with their operating instructions.

We accept no liability for loss of profit, loss of market or any other indirect or consequential loss whatsoever.

Product warranty and limit of liability are dealt with in our standard terms and conditions of sale or negotiated contract under which this document is supplied.

You must use this product as described in this manual. Read the manual before you install, operate, or maintain the product.

1 Safety and compliance.	6
1.1 Definition of Warnings and Cautions.	6
1.2 Trained personnel	6
1.3 Safety symbols.	7
2 Important safety information.	8
2.1 Mechanical hazards.	8
2.2 Electrical hazards.	9
2.3 Thermal hazards.	9
2.4 Hazards caused by materials and substances.	9
2.5 Danger of ignition.	11
2.6 Hazards caused by noise.	11
2.7 Risk of damage to the pump.	11
3 Description.	13
3.1 Principle of operation.	13
3.2 Lubricants and oil.	14
3.3 Supplied equipment.	14
4 Technical data.	16
4.1 Dimension drawing.	16
4.2 Performance curves.	21
4.3 Material of construction.	22
4.4 Ordering information.	23
5 Transportation.	24
5.1 Transport and packaging.	24
5.1.1 Unpack.	24
5.1.2 Remove the pump.	25
5.1.3 Lift the pump.	26
5.2 Mounting orientation.	27
6 Installation.	29
6.1 Placement.	29
6.2 Conforming utilisation.	30
6.3 Non-conforming utilisation.	30
6.4 Connection to the system.	31

Contents

6.5 Installation drawing.	32
6.6 Electrical connections.	33
7 Operation.	35
7.1 Media compatibility.	35
7.2 Start-up.	35
7.3 Operation.	36
7.3.1 Pumping of non-condensable gases.	36
7.3.2 Pumping of condensable gases and vapours.	37
7.3.3 Operating temperature.	38
7.3.4 Shutdown.	38
7.4 Ultimate pump pressure.	39
7.5 Taking out of use.	39
8 Maintenance.	40
8.1 Safety information.	40
8.2 Maintenance intervals.	40
8.3 Maintenance work.	44
8.3.1 Check the oil level.	44
8.3.2 Check the oil condition.	44
8.3.3 Change the oil.	45
8.3.4 Clean or replace the oil sight glass.	46
8.3.5 Clean the intake port dirt-trap and anti-suck back valve.	47
8.3.6 Replacement of electrical motor.	48
8.3.7 Check the coupling and coupling element.	50
8.3.8 Clean the motor cooling fan.	50
8.4 Service.	50
8.4.1 Return the equipment or components for service	50
8.5 Spare parts.	51
9 Fault finding.	53
10 Storage.	57
11 Disposal.	58
12 Accessories.	59
Legal declarations.	60

List of Figures

Figure 1. Section drawing of TRIVAC L	13
Figure 2. Dimension drawing - TRIVAC D 40 L	16
Figure 3. Dimension drawing - TRIVAC D 63 L	17
Figure 4. Dimension drawing - TRIVAC D 90 L	18
Figure 5. Pumping speed curve - TRIVAC D 40 L	21
Figure 6. Pumping speed curve - TRIVAC D 63 L	22
Figure 7. Pumping speed curve - TRIVAC D 90 L	22
Figure 8. Installation drawing - TRIVAC D 40 L	32
Figure 9. Installation drawing - TRIVAC D 63 L	32
Figure 10. Installation drawing - TRIVAC D 90 L	33

Safety and compliance

1 Safety and compliance

1.1 Definition of Warnings and Cautions

NOTICE:

For safe operation from the start, read these instructions carefully before you install or commission the equipment and keep them safe for future use.



Read all the safety instructions in this section and the rest of this manual carefully and make sure that you obey these instructions. The equipment must only be operated and maintained by trained personnel in the proper condition and as described in this instruction manual.

Obey local and state requirements and regulations. If you have any questions about safety, operation or maintenance of the device, please contact our nearest subsidiary.

Important safety information is highlighted as warning and caution instructions. Obey these instructions.



WARNING:

If you do not obey a warning, there is a risk of injury or death. Different symbols are used according to the type of hazard.



CAUTION:

If you do not obey a caution, there is a risk of minor injury, damage to equipment, related equipment or process.



NOTICE:

Information about properties or instructions for an action which, if ignored, will cause damage to the equipment.

We reserve the right to change the design and the stated data. The illustrations are not binding.

Keep the instructions for future use.

1.2 Trained personnel

For the operation of this equipment “trained personnel” are:

- skilled workers with knowledge in the fields of mechanics, electrical engineering, pollution abatement and vacuum technology and
- personnel specially trained for the operation of vacuum pumps

Safety and compliance

1.3 Safety symbols

The safety symbols on the products show the areas where care and attention is necessary.

The safety symbols that follow are used on the product or in the product documentation.

	Warning/Caution An appropriate safety instruction must be followed or caution to a potential hazard exists.
	Warning - Automatic start up The equipment can be remotely started.
	Warning - Dangerous voltage Identifies possible hazards from dangerous voltages.
	Warning - Heavy object Identifies a possible hazard from a heavy object.
	Warning - Hot surfaces Identifies a potential hazard from a hot surface.
	Warning - Trip hazard There is a risk of slipping, tripping or falling as a result of spilled liquids, trailing cords and pipes or other low-lying objects.
	Warning - Wear hearing protection
	Warning - Protective earth (ground) Earth point for electrical equipment.
	Warning - Risk of explosion There is a risk of explosion when you do the task.

Important safety information

2 Important safety information

2.1 Mechanical hazards

WARNING: BLOCKED EXHAUST

Risk of injury or damage to the equipment. If exhaust gases are collected or contained, the exhaust line may get pressurised. Make sure that the gas flow from the exhaust port is not blocked or restricted in any way.



The pressure in the oil box must not exceed 0.5 bar(g). An exhaust line too small in diameter or which is blocked can result in overpressure within the pump. The pump may get damaged or even burst if the pump is opened. Thus the exhaust line must be checked from time to time to make sure that there are no obstructions.

Design the exhaust line so that the pressure does not reach above 1.15 bar absolute (0.15 bar relative). The pressure regulation device must be installed by the end-user. We recommend to treat the gases from the pump exhaust in function of their nature.

-
1. Do not expose any part of the human body to the vacuum as this can cause injury.
 2. Do not step on the pump.
 3. Do not operate the pump without connecting the intake line or without fitting a blank flange.
 4. Do not open vacuum connections, oil filling plug and oil draining valve during operation of the pump as there is a risk of serious injury.
 5. The location at which the pump (including its accessories) is being operated must not have an angle more than 10 degrees from the vertical. Check that the inclination of the pump is less than 10 degrees from the vertical. Select the operating place so that all controls are easily accessible.
 6. The pump filled with oil must only be moved in its vertical position. Spilled oil involves the risk of falling.
 7. Take adequate safety precautions before you open the intake or exhaust port.
 8. Do not connect the intake line of the pump to a device with over atmospheric pressure.
 9. Operating the pump without oil or operating with incorrect direction of rotation can damage the pump.
 10. Do not use discarded seals. Always assemble using new seals.
 11. Follow the instructions concerning environmental protection to discard used oil.
 12. Touch the inner sections of the pumps only while wearing clean gloves and use clean tools, do the necessary work in clean and dry rooms.
 13. Do not allow the ingestion of any objects for example-screws, welding beads, nuts, washers, pieces of wire, fittings etc. away from the intake port of the pump. Objects falling into the pump can cause severe damage.
 14. To move the pump always use the suitable transport means.

Important safety information

2.2 Electrical hazards



WARNING: HAZARDOUS VOLTAGES

Risk of electric shock. Do not touch parts at high electric voltages, there is the risk of suffering severe injuries by an electric shock. Covers marked with this symbol must only be opened by trained electricians after having reliably de-energised (Lockout/Tagout) the equipment. Observe the national regulations for example - EN 50110-1 for Europe.



WARNING: AUTOMATIC RESTART

Risk of injury or damage to the equipment. After a mains power failure, the pump will run up automatically again. This also applies in the case of an emergency shut-down. To prevent the pump from running up automatically again, the pump must be integrated with a control arrangement such that it can only be switched on manually again after the mains power has returned.

1. Always operate the pump with a properly connected protective earth conductor and make sure that the motor terminal box is closed.
2. Lay electric feed lines so that there is no risk of tripping.
3. Lay the connecting lines so that these cannot be damaged. Protect the lines against humidity and contact with fluids. Avoid thermally stressing the lines by unfavourable laying. Provide strain relief for the connecting lines so that the plugs and the line connectors are not subjected to excessively high mechanical stresses.
4. Take appropriate precautions to make sure that the pump does not start while laying electric feed lines.

2.3 Thermal hazards



WARNING: HOT SURFACE

Risk of burn. During normal operation, the pump surface temperature can reach above 70 °C (158 °F). There is a risk of getting burns. Note the symbols on the pump indicating the hazards. If the pump is hot, wear the required protective clothing. All the work must be done using protection gloves if the pump is still warm.

1. Handle the pump only after venting and after it cools down.
2. Do not remove the oil-fill or oil-drain plugs while the pump is running. There exists the risk of suffering burns. Always wear protective gloves and protective goggles for protection against the oil.
3. Note the warning information on the housing surface. If these warning notices have been removed, covered or obstructed, include corresponding additional warning information.

2.4 Hazards caused by materials and substances



WARNING: HAZARDOUS SUBSTANCES

Risk of injury. When pumping toxic, chemical, radioactive and corrosive gases as well as pyrophoric substances, you must comply with the national and international safety regulations and guidelines. If such gases or substances are to be pumped, consult us first for the suitability of the pumps for special applications.

Important safety information



WARNING: CONTAMINATION HAZARD

Risk of injury. Contaminated parts can be detrimental to health and the environment. Before beginning with any work, first, find out whether any parts are contaminated. Adhere to the relevant regulations and take the necessary precautions when handling contaminated parts.

1. Liquid and solid particles or dust must not enter the pump. Install the adequate filters, separators and/or condensers. In case of doubt consult us.
2. The pump must be packaged in such a way that it will not be damaged during shipping and so that no harmful substances can escape from the package.
3. The vacuum and exhaust lines must be leak tight. Hazardous process gases may escape or the pumped gases can react with air or atmospheric humidity. After installation of the pump and after servicing work on the vacuum system, leak detection will always be necessary. When pumping hazardous gases we recommend to do leak detection regularly. Leaks in the pump cannot be ruled out under all circumstances. When pumping hazardous gases, the operator must make sure that leaks at the pump and in the vacuum system will not be a hazard.
4. Since not all application related hazards for vacuum systems can be described in detail in these operating instructions, we have a separate document (safety booklet) available in which the hazards and general safety concepts for design, operation and maintenance of vacuum systems are explained.
When planning to pump hazardous substances with this pump, read the related chapters in the safety booklet and in these operating instructions first. You can download the safety booklet from our homepage.
5. The pump is not suitable for oxygen pumping operation.
6. Before commissioning the pump, make sure that the media which are to be pumped are compatible with each other to avoid hazardous situations. All relevant safety standards and regulations must be observed.
7. If the pump has previously handled hazardous gases, implement the proper precautionary measures before opening the intake or exhaust connection. Before opening the pump, purge it for a longer period with an inert gas. If necessary, use gloves, a respirator and/or protective clothing and work under an exhaust hood. Firmly seal off the pump. When shipping the contaminated pump for servicing, also state the type of hazard. Refer to Service for more details.
8. When cleaning a system in which a pump has been integrated, all parts in contact with the medium need to be compatible with the cleaning agent to prevent a chemical reaction. Residues of the cleaning agent within the pump must be avoided.
9. The pump is not suitable for operation in the explosion hazard areas.

Important safety information

2.5 Danger of ignition



WARNING: IGNITION HAZARD

Risk of injury or damage to the equipment. The pumps including the accessories are fundamentally not suitable for pumping combustible and explosive gases or vapours.

2.6 Hazards caused by noise



CAUTION: NOISE HAZARD

Risk of injury. The noise level produced by the pump is less than or equal to 60 dB(A). Suitable hearing protection measures must be used while working.

2.7 Risk of damage to the pump

1. Before starting up for the first time, the motor circuit must be equipped with a suitable protective motor switch. Take note of the information in these operating instructions and on the electric motor (wiring diagram).
2. Do not allow the ingestion of small objects (screws, nuts, washers, pieces of wire, etc.) through the inlet port. So always use the inlet screen which is supplied as standard.
3. Do not use the pump for applications that produce abrasive or adhesive powders or condensable vapours that can leave adhesive or high viscosity deposits. When planning to pump vapours other than water vapour, contact our sales or service department for advice.
4. This pump is suitable for pumping water vapour within the specified water vapour tolerance limits.
5. Avoid vapours that can condense into liquids when being compressed inside the pump, if these substances exceed the vapour tolerance of the pump.
6. Before pumping vapours the pump must attain its operating temperature. It takes approximately 30 minutes for the pump to attain its operating temperature after the pump is started. During this warming up phase, the pump must be separated from the process, for example- by a blocking valve in the intake line.
7. In the case of wet processes we recommend the installation of liquid separators upstream and downstream of the pump as well as the use of the gas ballast.
8. The exhaust line must be laid so that it slopes down and away from the pump to prevent condensate from backstreaming into the pump.
9. The entry of particles and fluids must be avoided under all circumstances.
10. Reactive or aggressive substances in the pump chamber may impair the operating oil or modify it. In addition, such substances may be incompatible with the materials of the pump (viton, grey cast iron, aluminium, steel, resins, glass etc.).
11. Corrosion, deposits and cracking of oil within the pump are not allowed.

Important safety information

12. Normal amounts of humidity within the range of the pump's water vapour tolerance will not significantly affect pump performance when the gas ballast is active.
13. When operating the pumps at gas throughput, it is urgently recommended to connect an exhaust filter or use a suitable exhaust line. Here, the exhaust line must slope down and away from the pump.
14. In the case of custom pumps, note the information provided in the supplementary sheets.

3 Description



WARNING: EXPLOSION HAZARD

Risk of injury and damage to the equipment. The pump must not be installed and operated within explosion hazard areas.

TRIVAC L pumps are oil-sealed rotary vane dual-stage pumps.

The pump is designed for pumping the inert gases in the range of medium vacuum, between atmospheric pressure and end pressure of the pump. When removing condensable vapours, a gas ballast valve must be opened.

TRIVAC L pumps are capable of pumping gases, vapours and evacuating vessels or vacuum systems down into the medium vacuum range. The standard version of the pump is not suitable for pumping oxygen exceeding the concentration as found in the atmosphere and for pumping hazardous gases or extremely aggressive or corrosive media.

Through an intermediate flange, the drive motor of the pump is mounted to the coupling housing. The pump and motor shafts are directly connected by a flexible coupling. The oil-level glass, drain valve and the nameplate are arranged on the same side. All vacuum connections are default on the top of the pump.

3.1 Principle of operation

Figure 1. Section drawing of TRIVAC L

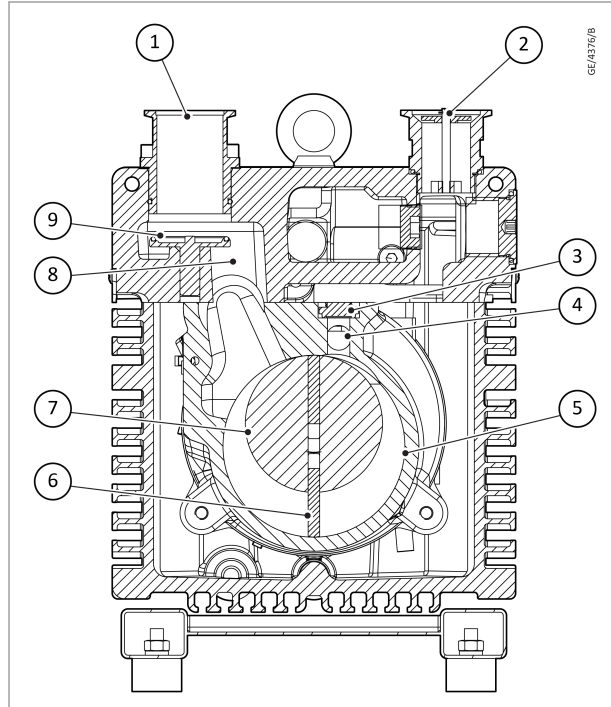

- | | |
|-------------------------|--------------------|
| 1. Intake port | 2. Exhaust port |
| 3. Exhaust valve | 4. Exhaust channel |
| 5. Pump chamber | 6. Vanes |
| 7. Rotor | 8. Intake channel |
| 9. Anti-suck back valve | |

Description

The pump is an oil-sealed rotary vane pump. The anti-suck back valve, gas ballast valve and oil return circuit are integrated functional elements. The pump is driven by a directly flanged motor.

The rotor, mounted eccentrically in the pump housing, has two radially sliding vanes which divide the pump chamber into several compartments. The volume of each compartment changes periodically with the rotation of the rotor.

As a result, gas is sucked in at the intake port. The gas passes through dirt trap sieve and open anti-suck back valve, then enters pump chamber. In the pump chamber, the gas is passed on and compressed after the inlet aperture is closed by the vane.

The oil injected into the pump chamber is used for sealing and lubricating. The slap noise of the oil in the pump which usually occurs when attaining the ultimate pressure is prevented by admitting a very small amount of air into the pump chamber.

The compressed gas in the pump chamber is ejected through the exhaust valve. The oil entrained in the gas is coarsely separated by the exhaust cover. There the oil is also freed of mechanical impurities. The gas leaves the pump through the exhaust port.

During compression, a controlled amount of air – the so-called gas ballast – can be allowed to enter the pump chamber by opening the gas ballast valve. The gas ballast stops the condensation of vapours in the pump chamber up to the limit of the water vapour tolerance as specified in the technical data for the pump.

The gas ballast valve is opened (position I and position II) and closed (position 0) by turning the gas ballast knob on the front.

A solenoid-operated gas ballast 24 V d.c. is available as an option to give automatic or remote control of gas ballast (refer to [Accessories](#) on page 59).

3.2 Lubricants and oil

The standard pumps are ready for operation with mineral oil.

For operating a pump we specify our vacuum pump oils which are supplied with the pumps.

Recommended oil: LEYBONOL LVO 130

For specific applications and pumping gas mixture, consult your local representative to select the right lubricant.

3.3 Supplied equipment

The equipment supplied with the pump includes:

- Pump with motor
- 1 centering ring DN 40 KF
- 1 centering ring DN 40 KF with dirt trap
- 2 clamping rings DN 40 KF
- Operating instructions or QR sheet to download it.
- Spare parts list.

Description

For protection during shipment, the connection ports are each blanked off by the blank flange. The pumps delivered from the factory are filled with LVO 130 oil.

Technical data

4 Technical data

4.1 Dimension drawing

Figure 2. Dimension drawing - TRIVAC D 40 L

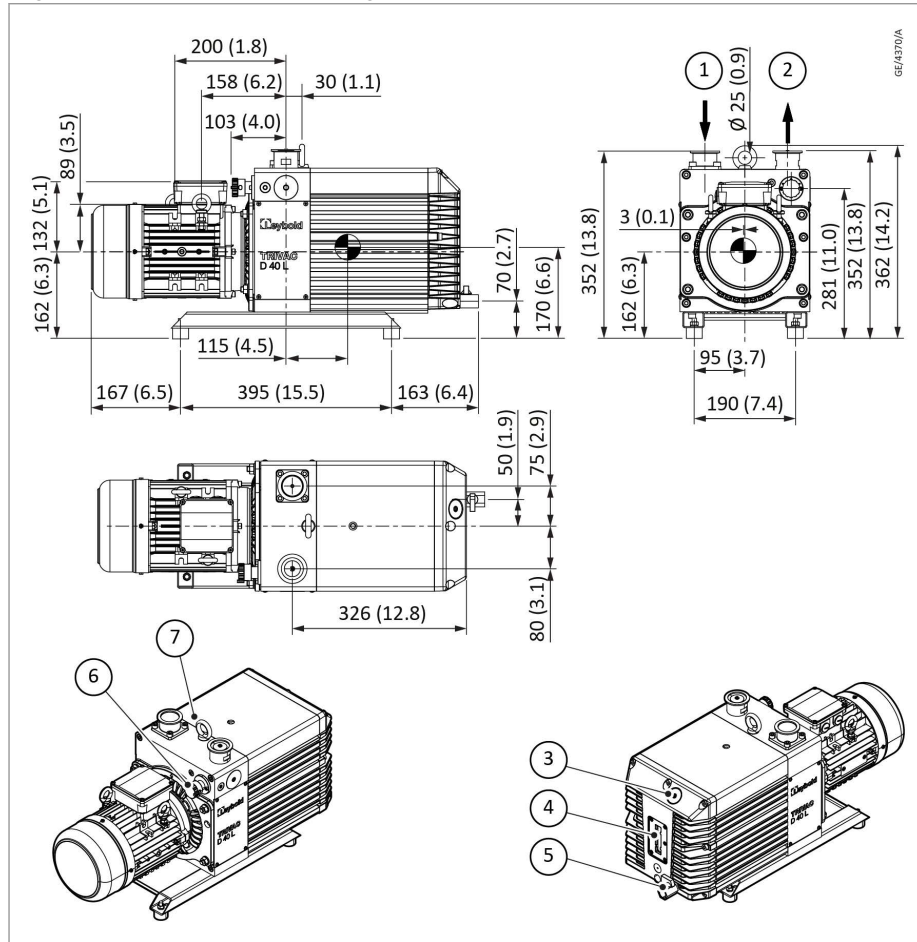

All dimensions are given in mm (inch).

- | | |
|---------------------|--------------------|
| 1. Inlet port | 2. Exhaust port |
| 3. Oil filling plug | 4. Oil sight glass |
| 5. Oil drain valve | 6. Gas ballast |
| 7. Lifting lug* | |

* For variants with motor

Technical data

Figure 3. Dimension drawing - TRIVAC D 63 L

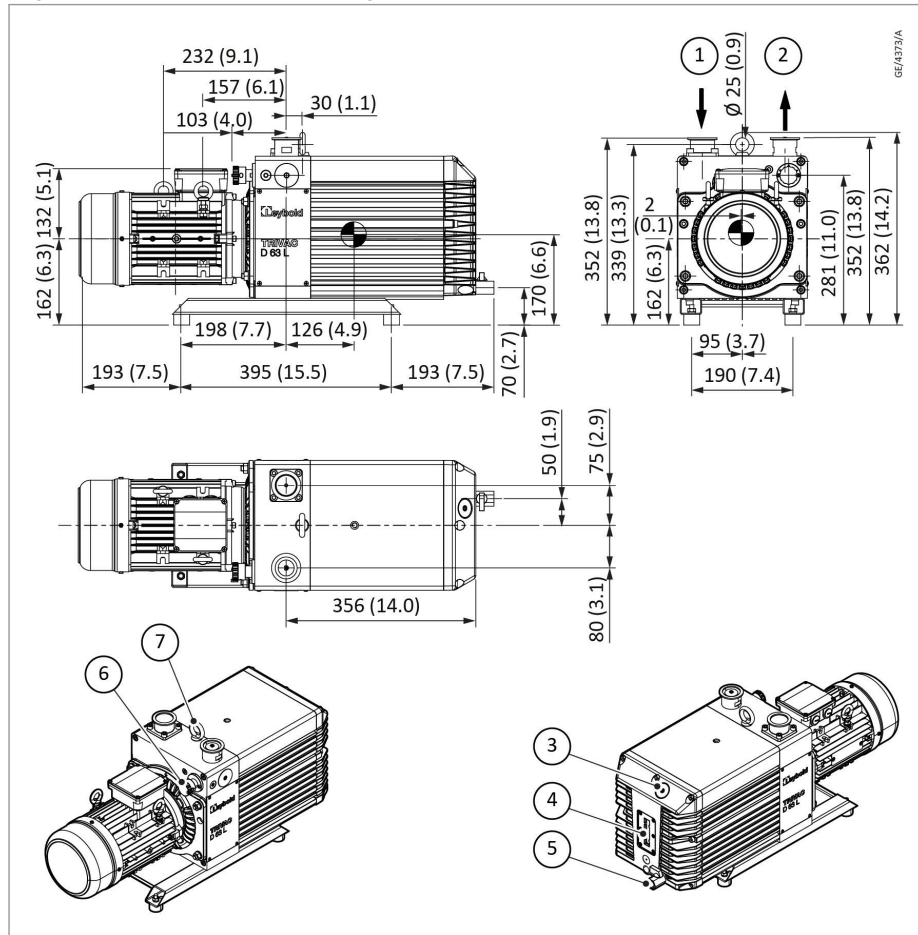

All dimensions are given in mm (inch).

- | | |
|---------------------|--------------------|
| 1. Inlet port | 2. Exhaust port |
| 3. Oil filling plug | 4. Oil sight glass |
| 5. Oil drain valve | 6. Gas ballast |
| 7. Lifting lug* | |

* For variants with motor

Technical data

Figure 4. Dimension drawing - TRIVAC D 90 L

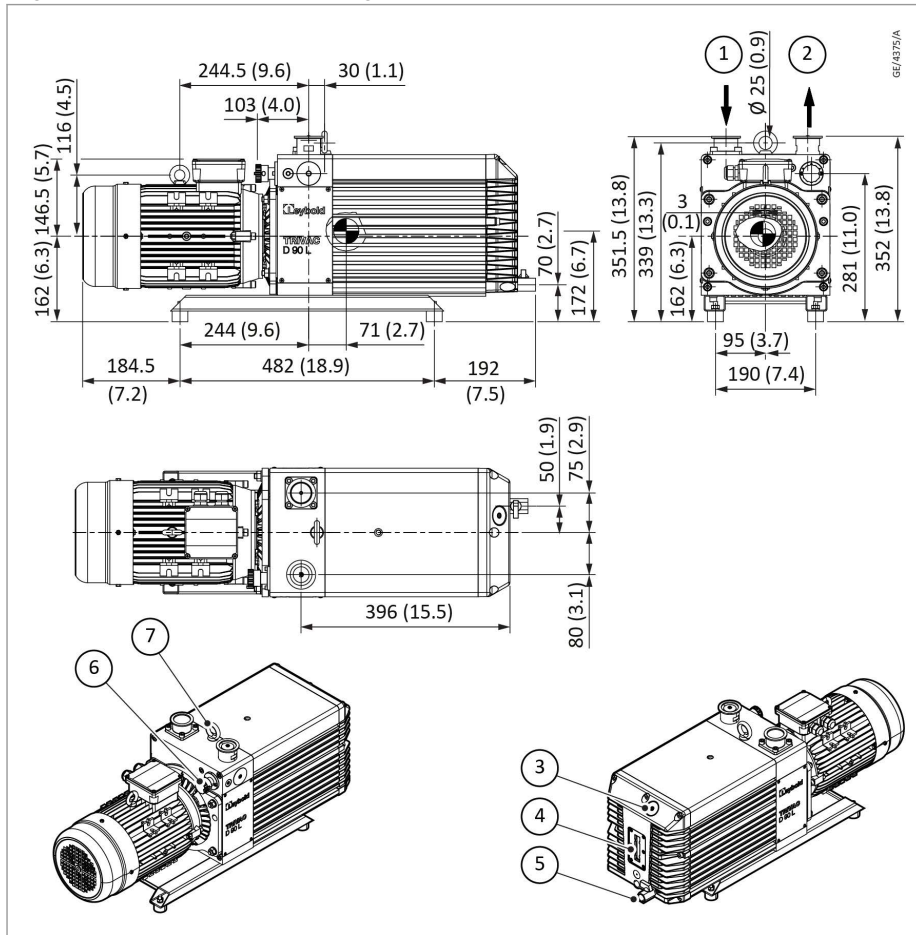

All dimensions are given in mm (inch).

- | | |
|---------------------|--------------------|
| 1. Inlet port | 2. Exhaust port |
| 3. Oil filling plug | 4. Oil sight glass |
| 5. Oil drain valve | 6. Gas ballast |
| 7. Lifting lug* | |

* For variants with motor

Technical data

Table 1 Technical data

Parameter	Unit	TRIVAC D 40 L		TRIVAC D 63 L		TRIVAC D 90 L	
		50 Hz	60 Hz	50 Hz	60 Hz	50 Hz	60 Hz
Nominal pumping speed ¹⁾	m ³ /h	49	59	67	80	92	110
	(cfm)	28.8	34.7	39.4	47.0	54.1	64.7
Pumping speed ¹⁾	m ³ /h	42	50	60	72	79	95
	(cfm)	24.7	29.4	35.3	42.3	46.4	55.91
Ultimate total pressure without gas ballast ¹⁾	mbar	3 x 10 ⁻³		3 x 10 ⁻³		3 x 10 ⁻³	
	(Torr)	2.2 x 10 ⁻³		2.2 x 10 ⁻³		2.2 x 10 ⁻³	
Ultimate total pressure with gas ballast ¹⁾ OP1	mbar	6 x 10 ⁻³		6 x 10 ⁻³		6 x 10 ⁻³	
	(Torr)	4.5 x 10 ⁻³		4.5 x 10 ⁻³		4.5 x 10 ⁻³	
Ultimate total pressure with gas ballast ¹⁾ OP2	mbar	2 x 10 ⁻²		2 x 10 ⁻²		2 x 10 ⁻²	
	(Torr)	1.5 x 10 ⁻²		1.5 x 10 ⁻²		1.5 x 10 ⁻²	
Water vapour tolerance with gas ballast OP2	mbar	35		30		25	
	(Torr)	26.2		22.5		18.75	
Water vapour capacity 50/60 Hz	g/h	1090	1308	1334	1601	1464	1757
	(lb/h)	2.40	2.88	2.94	3.52	3.22	3.87
Oil filling, minimum/maximum	l	3.1/4.1		3.3/4.4		3.6/4.8	
	(qt)	3.2/4.3		3.4/4.6		3.8/5.0	
Admissible ambient temperature	°C	10 ~ 40					
	(°F)	50 ~ 104					
Noise level without / with gas ballast ²⁾ OP1	dB(A)	58/60					
Pump dimensions (L x W x H)	mm	725 x 244 x 352		781 x 244 x 352		859 x 244 x 352	
	(inch)	28.5 x 9.6 x 13.8		30.7 x 9.6 x 13.8		33.8 x 9.6 x 13.8	
Pump dimensions without motor (L x W x H)	mm	568 x 244 x 352		598 x 244 x 352		684 x 244 x 352	
	(inch)	22.3 x 9.6 x 13.8		23.5 x 9.6 x 13.8		26.9 x 9.6 x 13.8	
Shipping dimensions (L x W x H)	mm	950 x 446 x 538		950 x 446 x 538		984 x 314 x 574	
	(inch)	37.4 x 17.5 x 21.1		37.4 x 17.5 x 21.1		38.7 x 12.3 x 22.5	

Technical data

Parameter	Unit	TRIVAC D 40 L		TRIVAC D 63 L		TRIVAC D 90 L	
		50 Hz	60 Hz	50 Hz	60 Hz	50 Hz	60 Hz
Net weight	kg (lbs)	79 174.1		85 187.3		96 211.6	
Net weight without motor	kg (lbs)	59 130.0		63 138.8		69 152.1	
Total shipping weight	kg (lbs)	91 200.6		97 213.8		109 240.3	
Intake connection	-	DN 40 ISO-KF					
Exhaust connection	-	DN 40 ISO-KF					

1) For DIN 28400 and following numbers, with standard gas ballast.

2) Operated at the ultimate pressure without/with gas ballast OP1, free-field measurement at a distance of 1 m.

Table 2 Unit conversion

Conversion factors	Different pressure units			Different pumping speed units			
	mbar (milli-bar)	torr	inches Hg vacuum		m ³ .h ⁻¹ (m ³ /h)	l.s ⁻¹ (l/s)	cfm (cubic feet per minute)
	1013	760	0	m ³ .h ⁻¹ = m ³ /h	1	0.278	0.589
1 lb = 0.453 kg	400	300	18.12	l.s ⁻¹ = l/s	3.60	1	2.12
1 qt = 0.946 l	133	100	25.98	cfm = cubic feet per minute	1.699	0.472	1
1 hp = 0.735 kW	4	3	29.80				
1 rpm = 1 min ⁻¹	1	0.75	29.89				
1 inch = 25.4 mm	0.1	0.075	29.92				
	1 atm (atmosphere) = 1013 bar			Example: 1 m ³ .h ⁻¹ = 0.589 cfm Note: The nominal pumping speed of a pump at 60 Hz is 20% higher than at 50 Hz.			
	1 Pa (pascal) = 0.01 mbar = 10 ⁻² mbar						
	1 bar = 1000 mbar						
	1 torr = 1.33 mbar						

Technical data

Table 3 Electrical data (three-phase motors)

Pump	Nominal supply (V)	Frequency (Hz)	Power (kW)	Product number
TRIVAC D 40 L, LVO 130	220/230/380/400	50	1.1	1019040V00
	220/230/380/400/415	50	1.1	1019040V01
	230/460	60	1.3	
	200	50	1.5	1019040V02
	200/380	60		
TRIVAC D 63 L, LVO 130	220/230/380/400	50	1.5	1019063V00
	220/230/380/400/415	50	1.5	1019063V01
	230/460	60	1.8	
	200	50	2.2	1019063V02
	200/380	60		
TRIVAC D 90L, LVO 130	220/230/380/400	50	2.2	1019090V00
	220/230/380/400/415	50	2.2	1019090V01
	230/460	60	2.6	
	200	50	3.0	1019090V02
	200/380	60	3.0	

4.2 Performance curves

Figure 5. Pumping speed curve - TRIVAC D 40 L

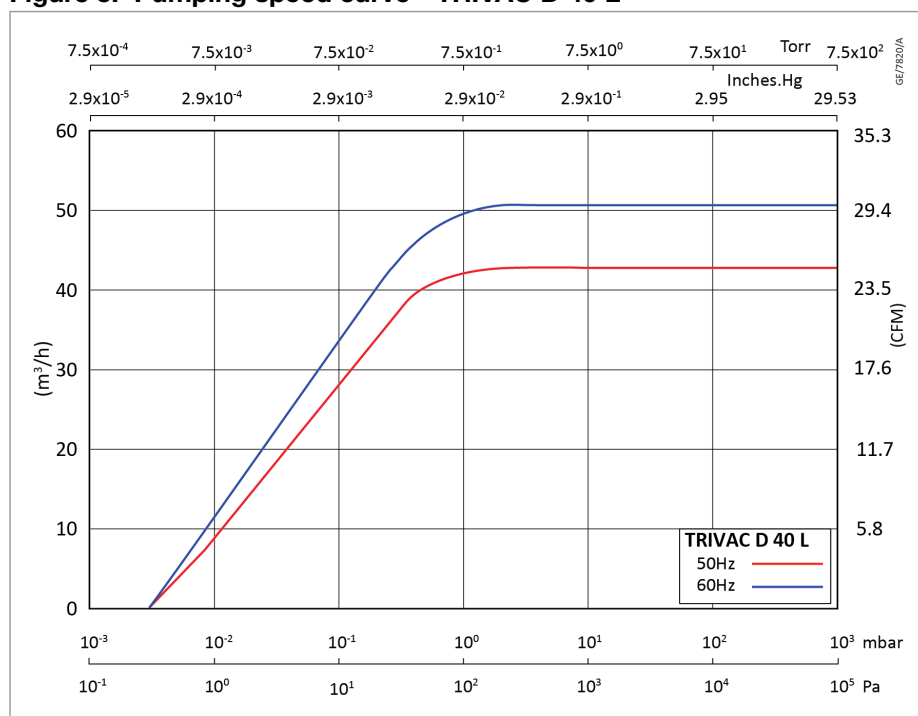

Technical data

Figure 6. Pumping speed curve - TRIVAC D 63 L

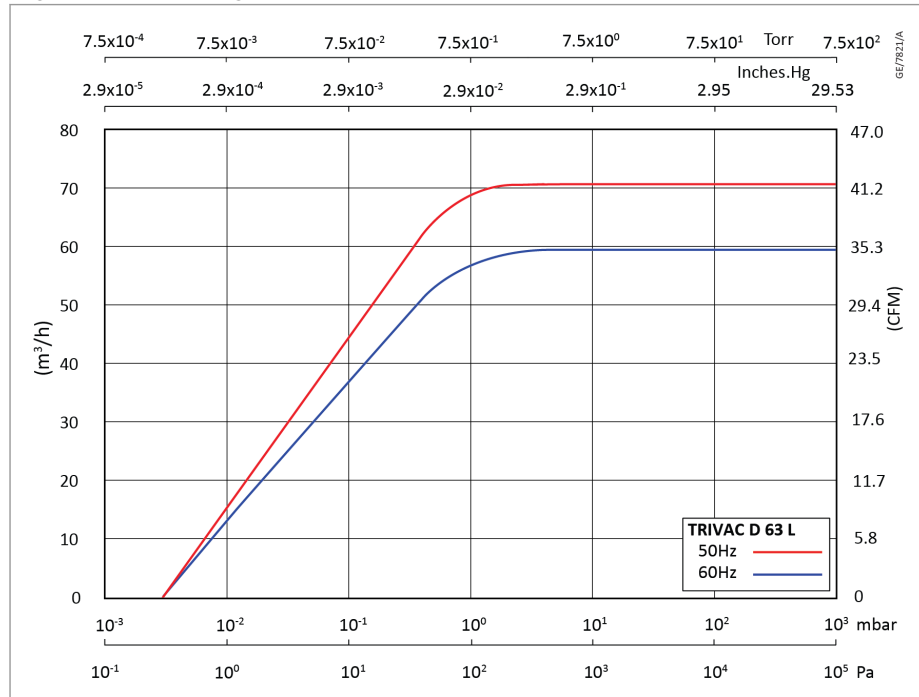
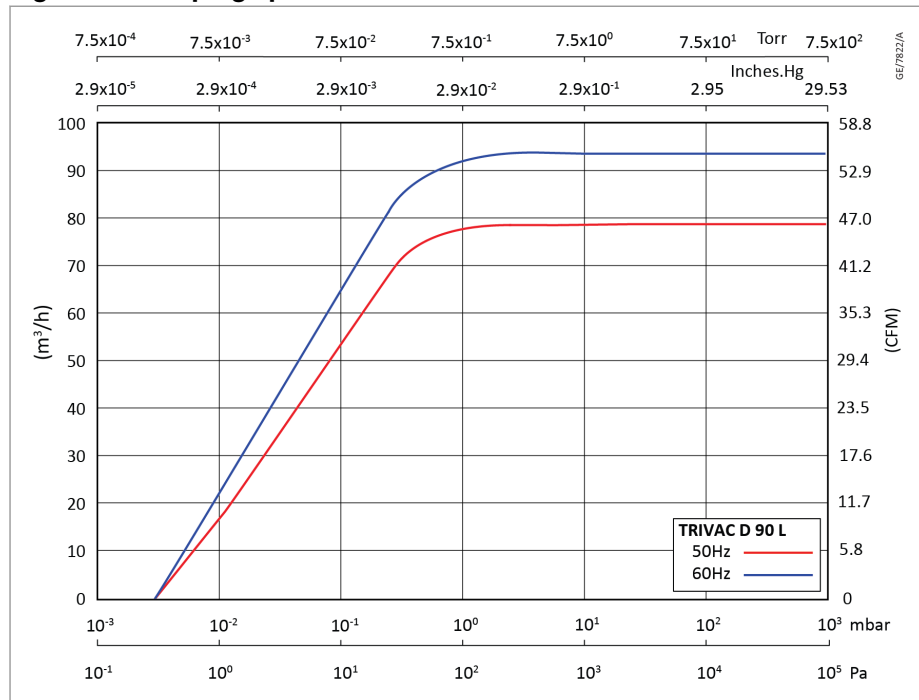

Figure 7. Pumping speed curve - TRIVAC D 90 L



4.3 Material of construction

Table 4 Material of construction

Component	Material
Cylinder/End plate	Cast iron
Rotor	Alloy structure steel
Coupling housing	Cast aluminium

Technical data

Component	Material
Mounting plate	Cast aluminium
Oil casing	
End plate	
HV stop plate	
Exhaust cover	
Oil casing	Extrusion aluminium alloy
Gasket	Polychloroprene rubber Styrene-Butadiene rubber
O-ring, piston O-ring	Fluoroelastomer (FKM)
Vane	Resistant epoxy resin and glass fabric
Lip seals	Fluoroelastomer (FKM)
Oil tubes	Stainless steel
Gas ballast knob	Rubber

4.4 Ordering information

Product	Part number
TRIVAC D 40 L, EU/CN, LVO 130	1019040V00
TRIVAC D 40 L, EU/US, LVO 130	1019040V01
TRIVAC D 40 L, JP/KR, LVO 130	1019040V02
TRIVAC D 40 L, BS, LVO 130	1019040V03
TRIVAC D 63 L, EU/CN, LVO 130	1019063V00
TRIVAC D 63 L, EU/US, LVO 130	1019063V01
TRIVAC D 63 L, JP/KR, LVO 130	1019063V02
TRIVAC D 63 L, BS, LVO 130	1019063V03
TRIVAC D 90 L, EU/CN, LVO 130	1019090V00
TRIVAC D 90 L, EU/US, LVO 130	1019090V01
TRIVAC D 90 L, JP/KR, LVO 130	1019090V02
TRIVAC D 90 L, BS, LVO 130	1019090V03

For ordering information of Roots system, refer to respective manual.

Transportation

5 Transportation

5.1 Transport and packaging

The pump passes a rigorous operating test in our factory and is packaged to avoid transport damages.

Check the packaging on delivery for transport damages. The outer packaging is made of a wooden pallet and cardboard or wood top.

Use a forklift to transport the pallet.

If possible transport the pump in its original packaging, if not available exercise due care.

For TRIVAC D 40 L and TRIVAC D 63 L

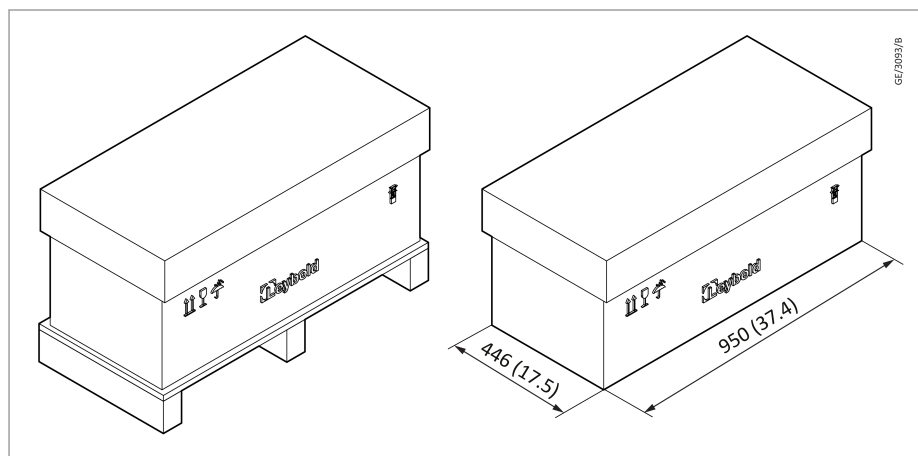

For TRIVAC D 90 L

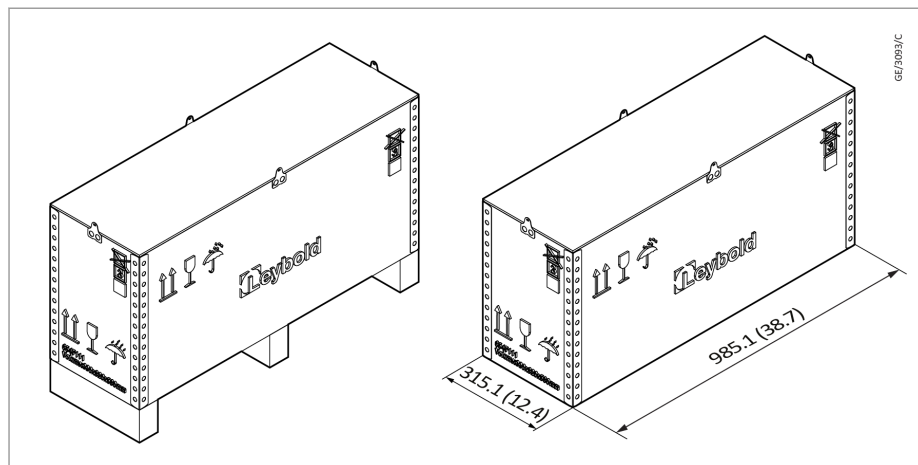

5.1.1 Unpack

Wear gloves and protection glasses before you unpack the pump.

1. Cut the 3 plastic straps carefully.
2. Remove the cardboard top and inner reinforced cardboard belt or wood box.

Transportation

For TRIVAC D 40 L and TRIVAC D 63 L

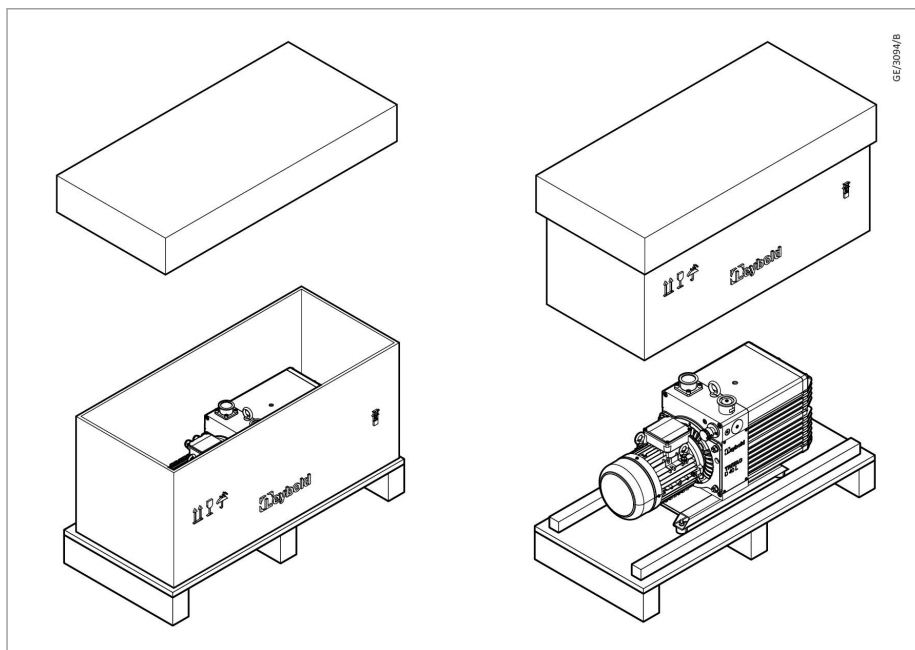

For TRIVAC D 90 L

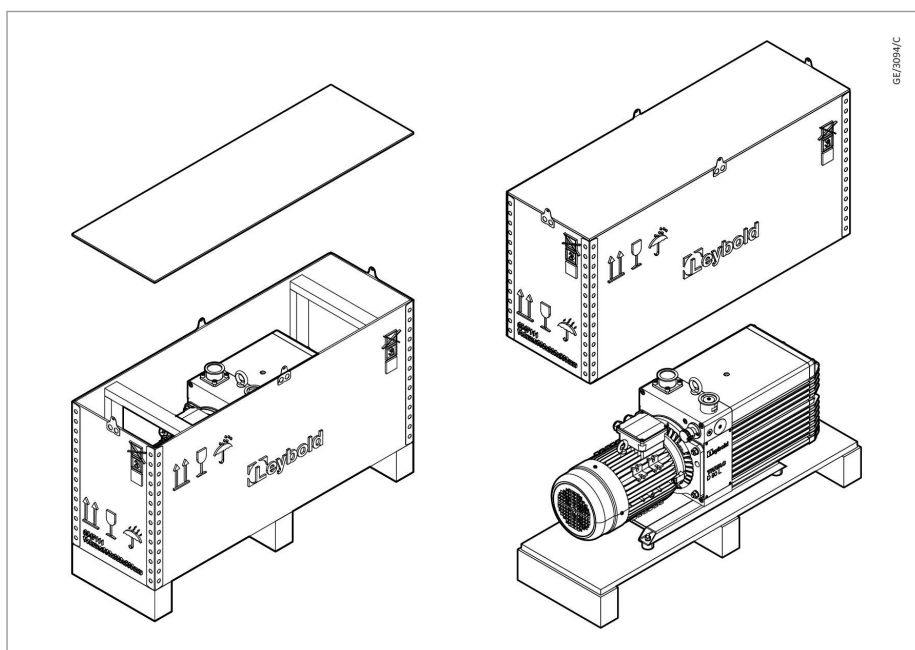

5.1.2 Remove the pump

The pump is bolted by screws. Remove the screws under the pallet using a 13 mm wrench.

The pump is then ready to be shifted or lifted off the pallet.

Recycle or dispose of the packing materials according to environmental laws.

Transportation

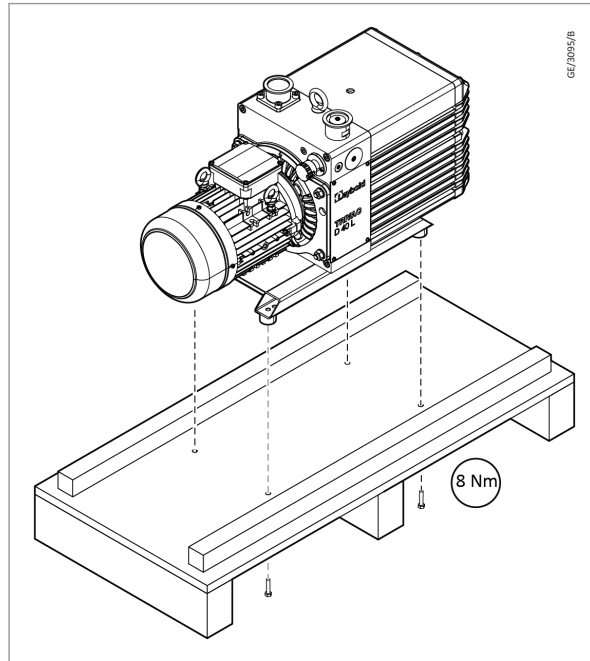

5.1.3 Lift the pump

WARNING: SUSPENDED LOAD

Risk of physical injury. Due to the pump weight, use only a suitable lifting device to lift the pump at the lifting lug (CE regulations). Lifting facilities are the only recommended way of handling the pump. Do not lift at the motor, cables connection boxes, flanges etc. Do not drag the pump from these points.



When you connect or remove the pump, do not move under hoisted loads. Fasten eye bolts only hand-tight. Eye bolts must be screwed in properly with full contact to the pump surface. Mounted eye bolts are only suitable for lifting the respective pump. They must not be used for other loads. Eye bolts must only be used in accordance with the conforming utilisations. Use eye bolts only with appropriate lifting devices.

Pumps that are filled with oil must only be moved while standing upright. Otherwise, the oil may escape. Avoid any other orientations while lifting.

The connection ports are blanked off by a blank flange.

Take these blank flange away before turning on the pump.

The pumps have their oil filled in.

For TRIVAC D 40 L and TRIVAC D 63 L

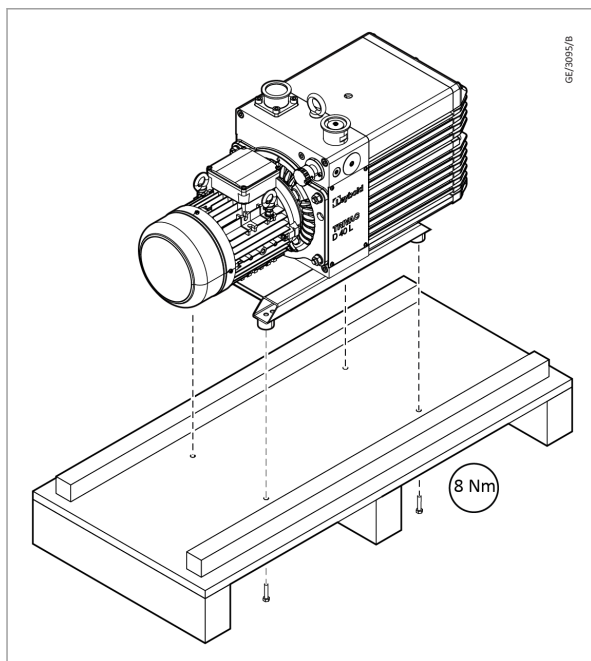

For TRIVAC D 90 L

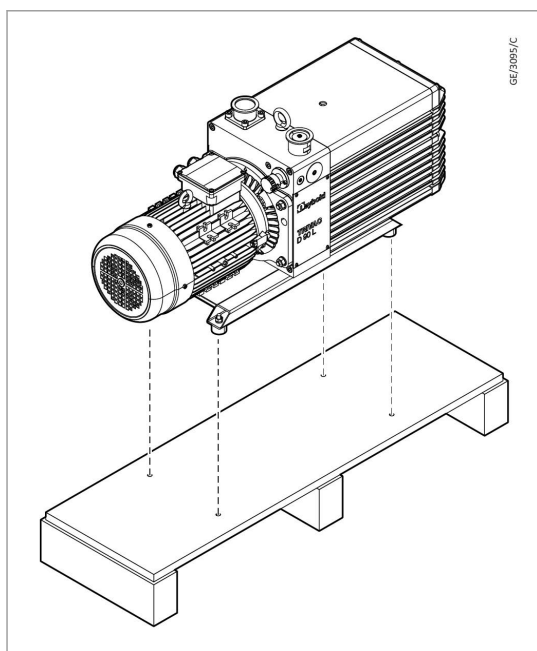

5.2 Mounting orientation



CAUTION: TRIP HAZARD

Hazard of slipping, tripping or falling due to oil leakage from the pump. Check the pump for the presence of any oil leaks. Risk of falling on oil spills. Take appropriate safety measures.

- Make sure that all safety regulations are observed.
- Use suitable lifting equipment according to the pump weight.

Transportation

- Check the nameplate. Do not use other pump elements than the lifting lugs as handles.
- Only use the lifting lugs which are provided on the pump to lift the pump with the specified lifting devices.
- Refer to the [Installation drawing](#) on page 32 for the space required to install the pump.
- A pump that has been filled with oil must only be moved in the upright position (horizontally). Otherwise, the oil may escape.
- The angle of the slope must not be more than 10 degrees.
- Avoid any other orientations while you move the pump.

6 Installation



WARNING: HAZARDOUS VOLTAGE

Risk of shock. Before you install the pump make sure that the pump is reliably disconnected from the electrical power supply and prevent the pump from running up inadvertently.



CAUTION: PUMP DAMAGE

Risk of damage to the equipment. Do not stand on the pump and place objects on the pump as these can cause deformation of the pump.

 **Note:**

Before conducting any kind of assembly work the personnel must be informed about potential hazards. Observe the safety information given in [Important safety information](#) on page 8.

Observe the following instructions step by step for the safe start-up.

6.1 Placement



CAUTION: TOPPLING HAZARD

Risk of toppling. The maximum tilt allowed for the pump is 10 degrees from the vertical. To firmly install the pump in place, insert bolts through bore holes (Ø 7 mm) in the rubber feet.

 **Note:**

The rubber feet act as vibration absorbers. They must therefore not be compressed by screws.

The pump can be set up on a flat, horizontal surface. Rubber feet under the coupling housing ensure that the pump can not slip.

The site chosen must allow for ready accessibility to connections and controls of the pump.

For adequate cooling of the pump, leave enough space at the air intake and exhaust points and for access and maintenance (refer to [Installation drawing](#) on page 32). Make sure to keep the fans, hoods and air intake of the motor clean. The pump must be kept clean (no dust deposit). Install the pump such that the oil level sight-glass can be easily read and will not be broken.

The site chosen must allow adequate air circulation to cool the pump (keep front and rear unobstructed).

Note the ambient conditions during operation. The ambient temperature must not exceed +40 °C (104 °F) and not drop below +12 °C (55 °F) (refer to [Technical data](#) on page 16).

For installation sites over 1000 m of standard elevation zero or a relative atmospheric humidity of over 90%, you must discuss this with technical sales.

Installation

The maximum amount of heat given off approximately corresponds to the rated motor power.

Install the pump such that only minimal quantities of dust can deposit on the surfaces. In those cases where dust deposits form, measures need to be introduced which make sure that these are removed regularly.

The maximum gas inlet temperature must not exceed 80 °C.

The maximum pressure at the inlet must not exceed atmospheric pressure (approximately 1013 mbar). Do not apply overpressure to the pump's inlet. The maximum exhaust pressure must not exceed 0.5 bar(g).

6.2 Conforming utilisation

The pumps can pump gases and vapours and evacuate vessels or vacuum systems in the fine vacuum range.

The pumps are suitable for pumping water vapour within the specified water vapour tolerance limits. Avoid vapours that can condense into liquids when being compressed inside the pump, if these substances exceed the vapour tolerance of the pump. In the case of wet processes we recommend the installation of liquid separators upstream and downstream of the pump.

6.3 Non-conforming utilisation

WARNING: HAZARDOUS SUBSTANCES



Risk of injury or damage to the equipment. The pump is not suited for pumping of:

- radioactive and toxic substances
- pyrophoric substances
- corrosive gases
- oxygen (or other highly reactive gases) at concentrations exceeding that of the atmosphere (> 21 % for oxygen).

CAUTION: MAINTENANCE SAFETY



Risk of damage to the pump. The standard pump is not suited for pumping hazardous gases or vapours. When cleaning a system in which the pump has been integrated, all parts in contact with the medium must be compatible with the cleaning agent so as to prevent a chemical reaction. Residues of the cleaning agent within the pump must be avoided.

Note:

The pumps are not suited for pumping liquids or media which carry large quantities of dust. Corresponding protection devices need to be provided.

6.4 Connection to the system

WARNING: EXHAUST EMISSION HAZARD



Risk of injury. Safely lead the exhaust gases away. Exhaust gases, depending on the type of application, may present a health hazard and/or may be detrimental to the environment.

The exhaust gases from the vacuum pump must be safely led away and subjected to post-treatment as required. To reduce the emission of oil vapours we recommend the installation of an additional exhaust filter (refer to [Accessories](#) on page 59). Depending on the type of application or the kind of pumped media, the corresponding regulations and information sheets must be observed.

CAUTION: EXHAUST PIPELINE BLOCKAGE



Risk of damage to the equipment. Note the specified cross sections for the connection lines.

If exhaust gases must be collected or contained, do not allow the exhaust line to become pressurised. The pressure in the oil box must not exceed 0.5 bar(g). An exhaust line that is too small in diameter or which is blocked can result in the formation of overpressure within the pump. Possible consequences can be a damaged or even burst open pump. Thus the exhaust line must be checked from time to time to ensure that there are no obstructions.

Do not operate the pump with a sealed exhaust line. There is the danger of injury.

Note:

To avoid back flowing condensate, install the exhaust line with a downward slope (lower than the pump) to prevent condensate from flowing back into the pump. If this is not possible, insert a condensate trap.

When oil mist is to be removed from the exhaust flow we recommend the use of the exhaust filter with lubricant return which is part of the pump system.

Before connecting the pump, remove the shipping seals from the connection flanges.

Retain the shipping seals in case you need to store the pump in the future.

The pump is shipped with intake and exhaust flanges mounted for vertical connection. You can easily convert the exhaust flange for horizontal connection. Connect the intake and exhaust lines with a centering ring and a clamping ring each. Use the centering ring with a dirt trap for the intake port.

Connect the intake and exhaust line using anti-vibration bellows, without placing any strain on the pump.

The maximum intake pressure must not exceed atmospheric pressure (1013 mbar).

The intake line must be clean. Deposits in the intake line may outgas and adversely affect the vacuum. The connecting flanges must be clean and undamaged.

The maximum throughput of the pump is equivalent to the pumping speed of the pump (refer to [Technical data](#) on page 16).

Installation

The cross-section of the intake line must be at least the same as that for the intake port. If the intake line is too narrow, it reduces the pumping speed. If the process gas contains dust, it is essential to install a dust filter in addition to the dirt trap supplied.

Dust filter is recommended to be installed horizontally. This makes sure that when you remove the filter, no particles fall into the intake port.

The pump may be operated with an inert gas ballast via a connection that is provided for this purpose. The gas ballast valve body can be replaced by a permanent or EM gas ballast valve with DN 16 KF connection. Matching connectors are available (refer to [Accessories](#) on page 59).

Gas ballast inlet pressure must not be more than 1013 mbar (absolute), and gas flow must be sufficient (about 1/10 of the pumping speed).

6.5 Installation drawing

Figure 8. Installation drawing - TRIVAC D 40 L

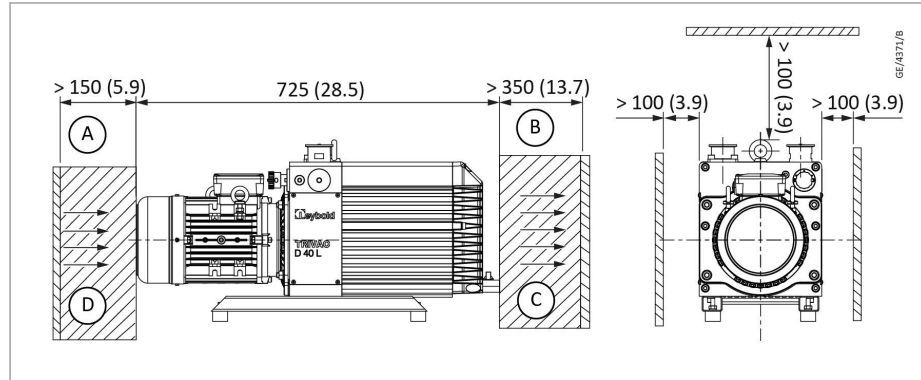

All dimensions given are in mm (inch).

- A. Space for the motor ventilation
- B. Space for pump ventilation
- C. Cooling air - pump
- D. Cooling air - motor

Figure 9. Installation drawing - TRIVAC D 63 L

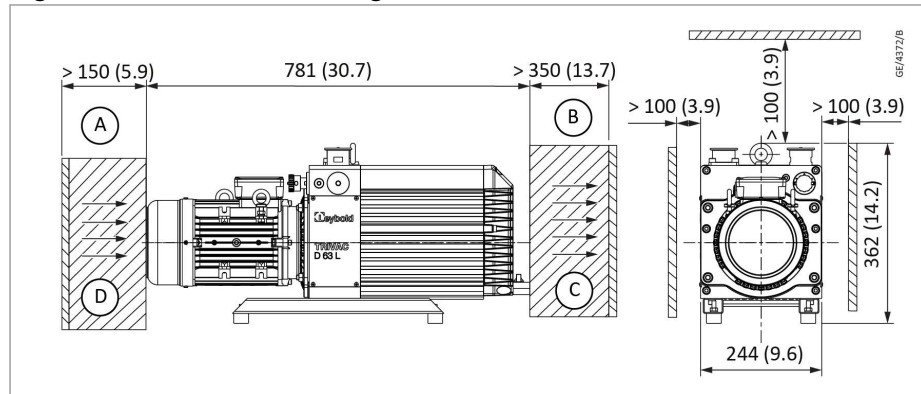

All dimensions given are in mm (inch).

- A. Space for the motor ventilation
- B. Space for pump ventilation
- C. Cooling air - pump
- D. Cooling air - motor

Figure 10. Installation drawing - TRIVAC D 90 L

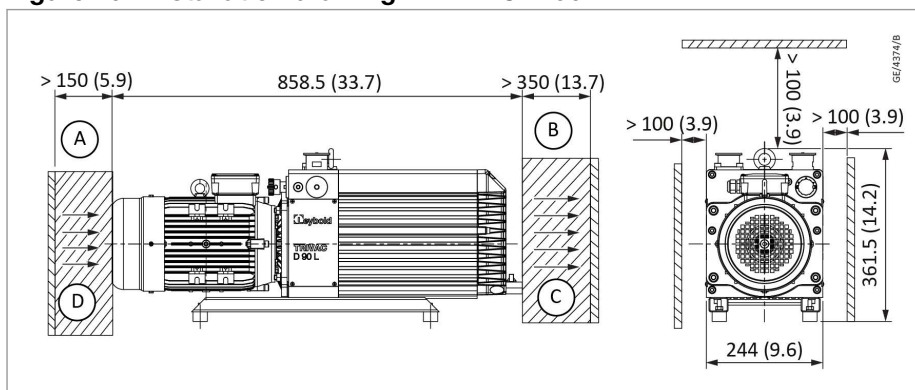

All dimensions given are in mm (inch)

- A. Space for the motor ventilation B. Space for pump ventilation
C. Cooling air - pump D. Cooling air - motor

6.6 Electrical connections



WARNING: PROTECTIVE EARTH CONNECTION

Risk of injury or damage to the equipment. The pump must be adequately earthed to prevent the accumulation of static electricity. The electrical junction box must only be opened and electrical connections made when no explosive atmosphere is present.



WARNING: DANGEROUS VOLTAGE

Risk of shock. The electrical connections must only be provided by a trained electrician as specified, for example, by the regulations EN 50110-1. Note the national regulations of the country in which the equipment is being operated.

During all connection work, the mains power supply lines must be de-energised (lock out/tag out). To prevent the pump from running up unexpectedly after a mains power failure, the pump must be integrated with the control system in such a way that the pump can only be switched on again manually. This applies equally to the emergency cut-out arrangements. Observe safety information given in [Electrical hazards](#) on page 9.



CAUTION: DAMAGE TO THE PUMP

Risk of damage to the equipment. Observe the direction arrow on the motor fan cover. It is recommended to check the direction of rotation with a phase sequence indicator.

Prolonged running of the motor in the wrong direction of rotation will damage the pump.

In the case of custom pumps note the information provided on a separate sheet.

For connecting the motor, follow the schematics provided on the motor nameplate or in its junction box, given your local mains voltage and frequency. Electrical connection work must only be carried out by a qualified electrician in accordance with the applicable safety rules, see IEC 60204-1 and 61010-1.

Installation

The pump is supplied with a three-phase motor but without accessories for electrical connection. They must be connected with the appropriate cable and a suitable motor protection switch.

Set the switch in accordance with the rating on the motor nameplate. Observe the diagram at the motor.

After connecting the motor and after every time you alter the wiring, check the direction of rotation. To do so, briefly switch on the motor and check whether a suitable cover (for example- a blank flange) is sucked on at the intake port. Otherwise, interchange two phases of the connection.

7 Operation



WARNING: OPERATION SAFETY

Risk of damage to the equipment. Do not start the pump more than six times within one hour to prevent the overloading of the motor. If frequent starts are needed, the pump must run continuously and be linked to the vacuum vessel using a valve. In that case, regulation will be made by the valve and not by the start/stop of the pump. With the valve closed, the pump consumes less energy.



WARNING: HOT SURFACE

Risk of burns. The pump in operation is hot and some surfaces could reach a temperature higher than 80°C (176°F). There is a risk of burn by touching. Take note of warning labels on the pump. Let the pump cool down before you start any work.



WARNING: HAZARDOUS WORKING CONDITIONS

Risk of injury. Wear ear protection in case of operation at high inlet pressure.

7.1 Media compatibility

Pumps can pump condensable gases and vapours, provided that the gas ballast valve is open and the pump has attained its operating temperature.

7.2 Start-up



WARNING: AUTOMATIC RESTART

Risk of injury or damage to the equipment. To prevent the pump from running up unexpectedly after a mains power failure, the pump must be integrated with the control system in such a way that the pump can only be switched on again manually. This applies equally to emergency cut-out arrangements.



WARNING: OPERATION SAFETY

Risk of injury or damage to the pump. Before starting the pump make sure that the pump and the fitted accessories meet the requirements of your application and that safe operation can be guaranteed.



WARNING: VACUUM HAZARD

Risk of exposure to the vacuum. Do not operate the pump with an open intake port. Vacuum connections, oil feed and discharge openings must not be opened while the pump is operating. Avoid exposing any part of the human body to the vacuum. There is the risk of suffering injury. Observe safety information given in [Mechanical hazards](#) on page 8.

 **Note:**

The pump is delivered filled with oil. Before you switch on the pump, make sure that the pump contains enough oil. The normal oil level in a standstill pump is in the upper half of the sight glass. Each time before you start up check the oil level. Do not operate the pump with an oil level below the

Operation

minimum. To add the oil, unscrew the oil-fill plug, add oil and screw the plug firmly back in.

Open all valves blocking the exhaust lines. Do not operate the pump with a blocked or constricted exhaust line.

Check the direction of rotation before starting the pump for the first time and after each change in the electrical connection (refer to [Electrical connections](#) on page 33).

On initial start-up, after prolonged idle periods or after an oil change, the specified ultimate pressure cannot be attained until the oil is degassed.

This can be done by running the pump for approximately 30 minutes with the intake line closed and the gas ballast valve open.

7.3 Operation

Note:

The pump can pump condensable gases and vapours, provided that the gas ballast valve is open and the pump has attained its operating temperature.

If exhaust gases must be collected or contained, do not allow the exhaust line to become pressurised. The pressure in the oil box must not exceed 0.5 bar(g). An exhaust line that is too small in diameter or which is blocked can result in the formation of overpressure within the pump. Possible consequences can be a damage or even burst if the pump is open. Thus the exhaust line must be checked from time to time to make sure that there are no obstructions.

7.3.1 Pumping of non-condensable gases

If the process contains mainly dry gases, the pump may be operated without gas ballast (position 0), provided that the saturation vapour pressure at operating temperature is not exceeded during compression.

If the composition of the mixture to be pumped is not known and if condensation in the pump cannot be ruled out, run the pump with dry air or dry inert gas ballast (position I or II) in accordance with [Pumping of condensable gases and vapours](#) on page 37.

7.3.2 Pumping of condensable gases and vapours

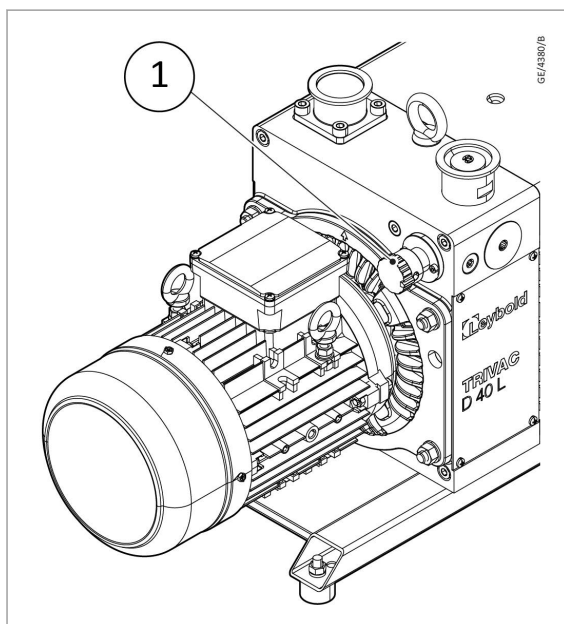

1. Gas ballast valve

The pump is equipped with a three-position manual gas ballast valve which operates with air.

The GB flow is valid for a pump operating at ultimate pressure (inlet closed) and for a GB gas supply of 1 bar (absolute).

To operate the gas ballast with an inert gas, remove the standard gas ballast and install the 'permanent gas ballast kits' with DN 16 KF connection available as an accessory. For remote control, fit an EM gas ballast valve kit (available as an accessory). The EM gas ballast valve must be supplied with 24 V d.c.

The gas ballast valve is operated manually by turning the rubber knob on the gas ballast head. There are 3 positions:

- 0 - closed
- I - small flow for small vapour quantities and
- II - standard flow for standard vapour quantities.

The pump is slightly louder if the gas ballast valve is open. With the gas ballast valve open (position I or II) and when the temperature is stabilised, the pump can pump pure water vapour up to the water vapour tolerance specified in the technical data. If the vapour pressure increases above the permissible level, the water vapour will condense in the oil of the pump.

When pumping vapours make sure that the gas ballast valve is open and that the pump has been warmed up for approximately 30 minutes with the intake line closed.

Note:

Vapour phases may only be pumped up to the permissible limit after the pump has attained its operating temperature.

During pumping, vapours may dissolve in the oil. This changes the oil properties and thus there is a risk of corrosion in the pump. Therefore, do

Operation

not switch off the pump immediately after the completion of the process. Instead, allow the pump to continue operating with the gas ballast valve open and the intake line closed until the oil is free of condensed vapours. We strongly recommend operating the pump in this mode for about 30 minutes after completion of the process.

For processes with a high proportion of condensable vapours, the intake line must be opened slowly only after the pump has reached the operating temperature.

One sign of condensation of vapours in the pump is a rise of the oil level during the operation of the pump.

In cyclic operation, the pump must not be switched off during the intervals between the individual working phases (power consumption is minimal when the pump is operating at ultimate pressure) but must continue to run with the gas ballast valve open and intake port closed (if possible via a valve).

Once all vapours have been pumped off from a process (for example, during drying), the gas ballast valve can be closed to improve the attainable ultimate pressure.

7.3.3 Operating temperature



CAUTION: HOT SURFACES

Risk of injury. There is the danger of receiving burns. Observe safety information given in [Thermal hazards](#) on page 9.

Proper operation of the pump is ensured in the ambient temperature range between 12 °C to 40 °C (55 °F to 104 °F).

At operating temperature, the surface temperature of the pump can be higher than 70 °C (156 °F).

If due to the ambient conditions this temperature range is to be exceeded at either end of the range, contact us.

The motor may accelerate with a delay when simultaneously an undervoltage is present at the motor and the pump is at the minimum permissible and ambient temperature.

Under such operating conditions the motor protection switch may respond. In this case, the motor may be started again.

7.3.4 Shutdown



CAUTION:

When pumping condensable media let the pump continue to operate with the gas ballast valve open and the intake line closed before switching off (refer to [Pumping of condensable gases and vapours](#) on page 37).

Under normal circumstances, switch off the pump. The intake port of the pump contains an anti-suck back valve which closes the intake port when the pump is shut down to prevent the pump oil from being sucked back into the vacuum chamber. The function of the valve is not impaired by gas ballasting. The anti-suck back valve is not a safety vacuum valve

If the pump was exposed to aggressive and corrosive media, we recommend that you let the pump continue to operate even during long

non-working intervals (for example, overnight) with the intake line closed and the gas ballast valve open. This avoids corrosion during idle periods and difficulties when re-starting the pump under conditions where the lubricant has been chemically modified.

If the pump running with mineral oil is to be shut down for an extended period after pumping aggressive or corrosive media or if the pump has to be stored, proceed as follows:

- Pump and operating agents may be contaminated
- If hazardous substances have been pumped, then these substances can escape from the pump and the oil. Introduce adequate safety precautions. Use gloves, face protection or a respirator, for example.
- Observe safety Information [Hazards caused by materials and substances](#) on page 9.
- Drain the oil (refer to [Change the oil](#) on page 45).
- Add clean oil until the oil level is at the “min” mark and let the pump operate for some time.
- Then drain the oil and add clean oil until the oil level is at the “max.” mark.
- Seal the connection ports. Special conservation or anti-corrosion oils are not necessary.
- Also, take note of the information given in [Transportation](#) on page 24 and [Storage](#) on page 57.

7.4 Ultimate pump pressure

If the system cannot produce the pressures specified in the technical data, measure the ultimate pressure directly at the intake port of the pump after you disconnect the pump from the system. The ultimate partial pressure of non-condensable gases can only be measured with a compression vacuum gauge or a partial pressure gauge. Precise measurements can only be obtained with calibrated instruments.

Upon initial start-up, after prolonged idle periods or after an oil change, it takes some time until the pump reaches the specified ultimate pressure. Wait until a stable pump temperature is reached and be sure the pump oil is degassed. It takes approximately 30 minutes. We recommend operating the pump initially with the gas ballast valve open.

The ultimate pressure depends on the pump temperature and the pump oil used. The best ultimate pressures can be obtained at a low pump temperature by using the recommended oil types.

7.5 Taking out of use

Contact us for all the queries about the disposal of spares, consumables or the entire pump.

Maintenance

8 Maintenance

8.1 Safety information



WARNING: DANGEROUS VOLTAGES

Risk of electric shock. The electrical connections must only be provided by a trained electrician as specified, for example, by the regulations EN 50110-1. Note the national regulations of the country in which the equipment is being operated.

Disconnect the electrical connections before disassembling the pump. Make sure that the pump cannot be accidentally started.

Observe the safety information given in [Electrical hazards](#) on page 9.



WARNING: HAZARDOUS SUBSTANCES

Risk of injury or damage to the equipment. Make sure that there is no potentially explosive atmosphere before conducting any maintenance work.

If the pump has pumped harmful substances, contrary to what has been stated in [Principle of operation](#) on page 13, ascertain the nature of hazard and take adequate safety measures. Observe the safety information given [Hazards caused by materials and substances](#) on page 9.

When disposing of used oil, you must observe the applicable environmental regulations.

All work must be carried out by suitably trained personnel. Maintenance or repairs carried out incorrectly will affect the life and performance of the pump and will void any warranty claims.

Note:

Due to the design concept, the pumps require very little maintenance when operated under normal conditions. The maintenance required is described in the sections below. In addition to this, a maintenance plan is provided in [Maintenance intervals](#) on page 40.

We offer practical courses on the maintenance, repair and testing of pumps. Further details are available on request.

If the pump is used in ambient air which is much contaminated, make sure that the air circulation and the gas ballast valve are not adversely affected.

When the pump has been pumping corrosive media we recommend that possibly planned maintenance work be carried out immediately to prevent corrosion of the pump while it is at standstill.

In case of special designs and variants please always indicate the serial number.

8.2 Maintenance intervals

Note:

The intervals stated in the maintenance schedule are approximate values for normal pump operation. Unfavourable ambient conditions and/or aggressive media may significantly reduce maintenance intervals.

Maintenance

Table 5 Maintenance interval

TRIVAC D 40 L, TRIVAC D 63 L, TRIVAC D 90 L	Measurement / Test quantity Operation / Auxiliary materials	Interval	Remarks
Operate the pump for at least 1 hour with gas ballast.		Daily	Condensed water is thus removed from the oil
Check the oil level, change the oil if required.	Oil: LVO 130 or special and alternative oils refer to Lubricants and oil on page 14.	Daily, before switching on the system	Refill: Only after the pump has been switched off. Refer to Check the oil level on page 44.
Check the quality of the oil, change the oil if required.	Visually (all oils)	Weekly	Normally the oil is light and transparent, oil change is required when discolourations increase. Refer to Check the oil condition on page 44.
	Chemically	6 months	According to DIN 51558, when the neutralisation number exceeds 2; then an oil change will be required. Refer to Check the oil condition on page 44.
	Mechanically	6 months	When the viscosity is 20 % above the one of fresh oil; then an oil change will be required. Refer to Check the oil condition on page 44.
Change the oil	Oil: LVO 130	6 months	<p>Oil change:</p> <ul style="list-style-type: none"> ▪ First oil change after 100 to 500 operating hours. ▪ Pump switched off and cold. <p>Change the oil while the pump is cold to avoid releasing adsorbed gases. Refer to Change the oil on page 45.</p> <p>Quantity of oil: Refer to Table: Technical data.</p>

Maintenance

TRIVAC D 40 L, TRIVAC D 63 L, TRIVAC D 90 L	Measurement / Test quantity Operation / Auxiliary materials	Interval	Remarks
Clean the oil level glass.	Suitable cleaning agent and compressed air.	Annually*	Clean the oil level glass with a cleaning agent and blow it out with compressed air under a suction hood. Use cleaning agents only corresponding to the national/international specifications. Observe the safety regulations when using cleaning agents. Refer to Clean or replace the oil sight glass on page 46.
Clean the intake dirt trap and anti-suck back valve in the intake port. Change them as required.	Suitable cleaning agent and compressed air.	6 month	<ul style="list-style-type: none"> ▪ Clean intake dirt trap with a cleaning agent and blow it out with compressed air under a suction hood. ▪ Replace the defective intake dirt trap. ▪ Clean the anti-suck back valve with a cleaning agent and dry it. Use a cleaning agent which complies with the national/international specifications. Observe the safety regulations when using cleaning agents. Refer to Clean the intake port dirt-trap and anti-suck back valve on page 47.
Check the edges of the teeth on the coupling element for any damages, change the coupling element as required.		Annually*	Refer to Replacement of electrical motor on page 48 and Check the coupling and coupling element on page 50.

Maintenance

TRIVAC D 40 L, TRIVAC D 63 L, TRIVAC D 90 L	Measurement / Test quantity Operation / Auxiliary materials	Interval	Remarks
Check the fan of the motor as well as the cooling fins on the motor for deposits, and clean as required.	Brush and industrial vacuum cleaner.	Annually*	Clean before the maintenance interval has elapsed when the pump or the motor gets too warm. Caution: Switch off the pump and make sure that it does not run inadvertently (disconnect from the mains).Refer to Clean the motor cooling fan on page 50.

* For normal applications the maintenance interval is 1 year or 6000 hours.

The recommendation above is only for pumps running in normal application. In case of running in medium and harsh applications, the maintenance interval needs to be shortened according to application requirements.

If other type of oil is used for the pump, the maintenance interval needs to be adjusted accordingly.

We recommend that you service the pump every three years covering the following:

- Cleaning
- Checking the individual components
- Exchange of all seals
- Functional check.

This service must be run by the Leybold Service.

Maintenance

8.3 Maintenance work

Depending on the process involved, dangerous substances may escape from the pump and oil. Take the appropriate precautions. Observe safety regulations.

Do not mount used seals, replace them with new seals.

8.3.1 Check the oil level



CAUTION: MAINTENANCE SAFETY

Risk of damage to the equipment. Check and top up oil only after having shut down the pump first. Note the safety information given in [Thermal hazards](#) on page 9 and [Hazards caused by materials and substances](#) on page 9.

During the operation of the pump, the oil level must always remain between marks on the oil-level glass. Refer to [Table: Maintenance interval](#). The amount of oil must be checked and topped up as required.

The oil level must be checked at least once a day. Stop the pump and filling oil when needed.

Pumps that are not directly delivered from us, for example- in systems, may have been filled with oils different from LVO 130. In this case, a refilling with LVO 130 may cause problems. Therefore check the oil type before refilling and fill in or change the oil with suitable oil.

Overfilling leads to oil losses at high intake pressures. High oil consumption often indicates that exhaust filters are clogged.

8.3.2 Check the oil condition

The ageing process for the standard operating fluid LVO 130 respectively (refer to [Lubricants and oil](#) on page 14) will depend very much on the area of application for the pump.

There exist the following ways of checking the oil condition:

1. Visual check: Normally the oil is clear and transparent. If the oil darkens, it must be changed.
2. Chemical check: The neutralisation number of LVO 130 oil is determined according to DIN 51558. If it exceeds 2, the oil must be changed.
3. Viscosity check: If the viscosity of LVO 130 at 25 °C exceeds a level of 240 mPas (20% higher than the viscosity of fresh oil) an oil change is recommended.

If gases or liquids dissolved in the oil result in a deterioration of the ultimate pressure, the oil can be degassed by allowing the pump to run for approximately 30 minutes with the intake port closed and the gas ballast valve open.

When checking the oil, switch off the pump first and drain out the required amount of oil through the oil drain valve from the warm pump into a beaker or similar container.

Note the maintenance safety information given in [Safety information](#) on page 40.

8.3.3 Change the oil

WARNING: HAZARDOUS SUBSTANCES



Risk of injury or damage to the pump. Hazardous substances may escape from the pump and the oil. If there is a danger that the operating agent may present a hazard in any way due to decomposition of the oil or because of the media which have been pumped, you must determine the kind of hazard and make sure that all necessary safety precautions are taken. Use gloves, face protection or a respirator, for example.

Observe safety information given in [Thermal hazards](#) on page 9 and [Hazards caused by materials and substances](#) on page 9.

Change the oil while the pump is cold to avoid releasing adsorbed gases. If releasing adsorbed gases has no problem, change the oil after the pump has been switched off and while the pump is still warm.



WARNING: HOT SURFACE

Risk of burn. With the pump warm from the operation, both pump and oil can get so hot that there is the risk of suffering burns. If required, wear gloves.

Note:

Check and top up oil only after the pump has been shut down.

When disposing of waste oil, observe the applicable environmental protection regulations.

When changing the oil use the same type of oil which was previously in the pump. If you want to change the type of oil entirely consult us first.

The oil must be changed after the first 500 operating hours and then at least every 2000 - 3000 operating hours or after one year. At high intake pressures and/or high intake temperatures when pumping contaminated gases, the oil will have to be changed more frequently.

Further oil changes must be made before and after the long-term storage of the pump.

If the oil becomes contaminated too quickly, install a dust filter (refer to Accessories).

Contact us for more information on this matter.

Maintenance

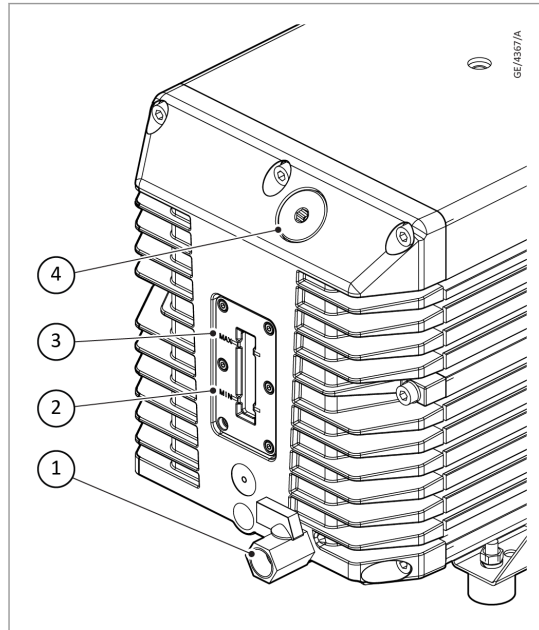

- | | |
|-----------------------------|-----------------------------|
| 1. Oil drain valve | 2. Oil level mark - minimum |
| 3. Oil level mark - maximum | 4. Oil filling plug |

Required tools:

- Allen key 12 mm.

To change the oil do the procedure as follows:

- Open the oil-drain valve and drain the used oil into a suitable container.
- When the oil flow slows down, close the oil-drain valve, switch on the pump (for maximum 10 seconds) and switch it off. Drain the remaining oil.
- Close the oil drain valve, unscrew the oil-fill plug and fill the oil in the pump to meet the oil level requirement. Then screw the oil filling plug.
- In case of severe pollution, the pump should be flushed by filling with fresh oil up to the bottom edge of the oil-level glass, run the pump for a short time and then change the oil again.
- When disposing of used oil, observe the relevant environmental regulations.

 **Note:**

We can only guarantee that the pump operates as specified in the technical data if the lubricants recommended by us are used.

8.3.4 Clean or replace the oil sight glass

An oil sight glass is assembled in the oil casing end plate, which will indicate the oil level. If the oil sight glass is dirty, the user will not see the oil level directly and miss to refill the oil to meet the requirement. Clean or replace the oil sight glass is needed.

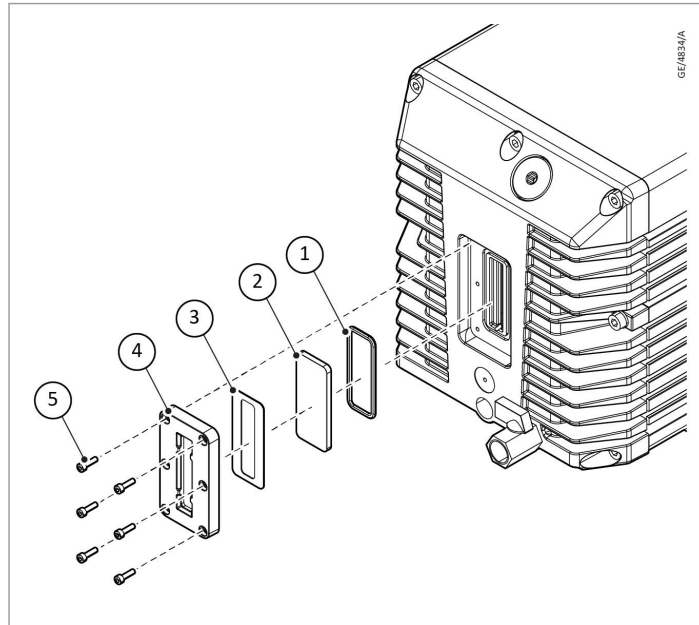

- | | |
|-----------|------------------|
| 1. O-ring | 2. Glass |
| 3. Gasket | 4. Glass bracket |
| 5. Screws | |

Required tools: Allen key 3 mm

To clean or replace the oil sight glass do the procedure as follows:

1. Use the Allen key to remove 6 screws.
2. Remove the oil sight glass bracket, gasket, glass and O-ring.
3. Replace the used parts if necessary.
4. Re-assemble the oil sight glass in the reverse sequence.

Refer to [Table: Oil sight glass kit](#) for more information.

8.3.5 Clean the intake port dirt-trap and anti-suck back valve

A wire-mesh screen is located in the intake port of the pump to act as a dirt trap for foreign objects. It must be kept clean to avoid a reduction of the pumping speed. An anti-suck back valve is located inside the intake port to stop the oil from returning to the intake pipeline. It must be kept clean to prevent function failure lead to oil returning to the intake pipeline.

For this purpose, remove the dirt trap and anti-suck back valve from the intake port and rinse them in a suitable vessel with solvent. Then thoroughly dry them with compressed air.

If the dirt trap is defective, replace it with a new one.

Note:

The cleaning intervals depend on the application. If the pump is exposed to large amounts of abrasive materials, a dust filter must be fitted into the intake line.

Maintenance

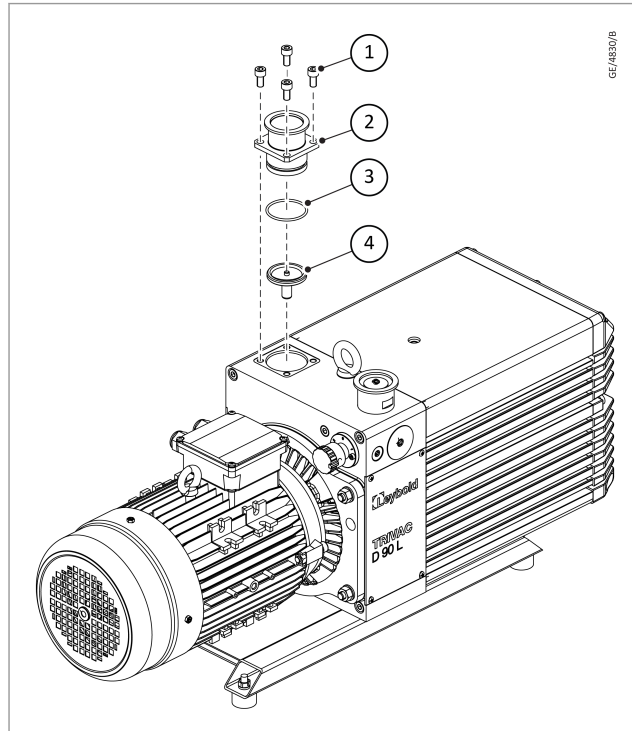

1. Screw
2. Inlet port
3. O-ring
4. Anti-suck back valve with O-ring

Tools required:

- Necessary tools to disassemble the customer intake hose or pipe if needed.
- Allen key 6 mm
- Plier

To clean the intake port dirt-trap do the procedure as follows:

- Disassemble the intake hose or pipe.
- Take out the wire-mesh screen and clean it using a suitable solvent.
- Use Allen key 6 mm to disassemble the intake port.
- Use a plier to take the anti-suck back valve out and clean it using a suitable solvent.
- Re-assemble the dirt trap in the reverse sequence.

Refer to [Table: Inlet valve kit](#) for more information.

8.3.6 Replacement of electrical motor



WARNING: DANGEROUS VOLTAGE

Risk of electric shock. Before starting work, must disconnect the motor from the power supply. Observe safety information given in [Electrical hazards](#) on page 9.

The motor can only be changed with an identical one from the same manufacturer and marking.

In case other motors are used, the pump loses its CE certification.

Maintenance

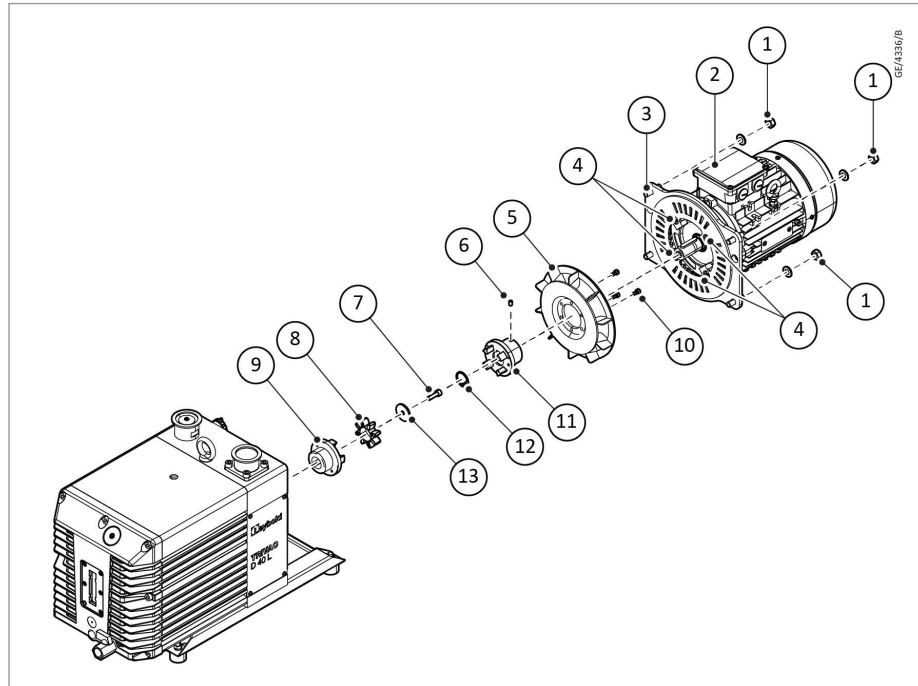

- | | |
|---------------------------|---------------------|
| 1. Nut | 2. Electric motor |
| 3. Motor flange | 4. Screws of flange |
| 5. Cooling fan | 6. Locking screw |
| 7. Lock screw | 8. Coupling element |
| 9. Coupling (pump side) | 10. Screw |
| 11. Coupling (motor side) | 12. Snap ring |
| 13. Washer | |

Required tools:

- Wrench 16 mm
- Internal snap ring plier
- Allen key 3 mm
- Allen key 4 mm
- Allen key 6 mm
- Possibly a puller for the coupling

To replace the motor do the procedure as follows:

- Disconnect the motor power supply
- Disconnect the motor main connections
- Remove the motor connection nuts with wrench 16 mm
- Remove the motor from the coupling housing
- Remove the coupling element
- Remove the coupling with Allen key 3 mm
- Use an internal snap ring plier to remove the snap ring
- Remove the coupling with fan, use a puller if necessary
- Disassemble the cooling fan from coupling using Allen key 4 mm if necessary
- Disassemble the motor flange with Allen key 6 mm
- Re-assemble the new motor in the reverse sequence.

Maintenance

8.3.7 Check the coupling and coupling element

A visual inspection as to the presence of any damage needs to be done.

If the couplings are damaged, they must be replaced.

Check the edges of the teeth on the coupling element for any damages, change the coupling element as required.

Refer to [Table: Coupling unit kit](#) for more information.

8.3.8 Clean the motor cooling fan



WARNING: MAINTENANCE SAFETY

Risk of injury or damage to the equipment. Do not disassemble the motor cooling fan cover while the pump is in operation, shut down the pump first.

Tools required:

- Cross screwdriver
- Brush
- Industrial vacuum cleaner

To clean the motor cooling fan:

- Shut down the pump
- Unscrew the motor fan cover
- Clean the motor cooling fan as required
- Reassemble the motor fan cover in the reverse sequence.

8.4 Service

8.4.1 Return the equipment or components for service

Before you send your equipment to us for service or for any other reason, you must send us a completed Declaration of Contamination of Vacuum Equipment and Components – Form HS2. The HS2 form tells us if any substances found in the equipment are hazardous, which is important for the safety of our employees and all other people involved in the service of your equipment. The hazard information also lets us select the correct procedures to service your equipment.

We provide instructions for completing the form in the Declaration of Contamination of Vacuum equipment and Components – Procedure HS1.

If you are returning a vacuum pump, note the following:

- If a pump is configured to suit the application, make a record of the configuration before returning the pump. All replacement pumps will be supplied with default factory settings.
- Do not return a pump with accessories fitted. Remove all accessories and retain them for future use.
- The instruction in the returns procedure to drain all fluids does not apply to the lubricant in pump oil reservoirs.

Download the latest documents from leybold.com/en/downloads/download-documents/declaration-of-contamination/, follow the

procedure in HS1, fill in the electronic HS2 form, print it, sign it, and return the signed copy to us.



NOTICE:

If we do not receive a completed HS2 form, your equipment cannot be serviced.

8.5 Spare parts

Note:

To guarantee the safe operation of the pump, use only original and genuine spare parts and accessories. When ordering spare parts and accessories, always state the pump type and serial number. You can find part numbers in the spare parts list.

The pump loses its CE certification if non-genuine parts are used.

Consumables and main spare parts kits for the pumps are usually available in stock at our service centres. The list of these parts is given hereafter and in the spare parts table where the contents of each kit are given in detail.

- Oils (Special oils refer to the specific notice of the pump or contact us)
- Shaft seal maintenance kit
- Major maintenance kit

We recommend using these kits which have been defined to allow optimal maintenance or repair. Individual spare parts may need a longer delivery time.

Table 6 Major maintenance kit

Part number	Part description	Remark
EK3002614150	Major maintenance kit for TRIVAC D 40 L	includes vanes, exhaust valves, springs, bushings, shaft seals, O-rings, gaskets and other sealing parts
EK3002614151	Major maintenance kit for TRIVAC D 63 L	
EK3002614152	Major maintenance kit for TRIVAC D 90 L	

Table 7 Gas ballast kit

Part number	Part description	Remark
GK6538488	Gas ballast kit for TRIVAC D 40/63/90 L	includes gas ballast cap, body, screw and O-ring
GM6539427	Gas ballast cap (10 pcs)	

Table 8 Oil sight glass kit

Part number	Part description	Remark
GK6538266	Oil sight glass kit for TRIVAC D 40/63/90 L	includes oil sight glass, gasket and O-ring

Table 9 Coupling unit kit

Part number	Part description	Remark
GK6541321	Coupling unit kit for TRIVAC D 40/63 L	includes motor side coupling, cir-clip, jack screw, plastic element and pump side coupling
GK6540642	Coupling unit kit for TRIVAC D 90 L	

Maintenance

Part number	Part description	Remark
GM6539758	TRIVAC D 40/63/90 L coupling element (2 pcs)	-

Table 10 Inlet valve kit

Part number	Part description	Remark
GK88851240	Inlet valve kit for TRIVAC D 40/63/90 L	includes anti-suck back valve and O-ring
GM88836246	Inlet port O-ring (10 pcs)	

Table 11 Oil drain valve

Part number	Part description	Remark
G6545717	Oil drain valve TRIVAC D 40/63/90 L	-

Table 12 Motor

Part number	Motor description	Available for
E6535551	3-phase IE3 motor, 1.1 kW, EU/CN	1019040V00
G6535554	3-phase IE3 motor, 1.1 kW, EU/US/CN	1019040V01
G6535557	3-phase IE3 motor, 1.5 kW, JA/KO	1019040V02
E6535552	3-phase IE3 motor, 1.5 kW, EU/CN	1019063V00
G6535555	3-phase IE3 motor, 1.5 kW, EU/US/CN	1019063V01
G6535558	3-phase IE3 motor, 2.2 kW, JA/KO	1019063V02
E6535553	3-phase IE3 motor, 2.2 kW, EU/CN	1019090V00
G6535556	3-phase IE3 motor, 2.2 kW, EU/US/CN	1019090V01
G6535559	3-phase IE3 motor, 3 kW, JA/KO	1019090V02

Table 13 Spare part for accessories

Major maintenance kit	Description	Remarks
GK3002614101	Oil mist filter element TRIVAC D 40 L	includes mist filter element and gaskets
GK3002614102	Oil mist filter element TRIVAC D 60/90 L	
GK3002614103	Oil return kit	includes oil return pipe and connections
GM6547883	Seal plug for gas ballast hole (10 pcs)	-
GM6549582	Seal plug for thermal switch hole (10 pcs)	-

9 Fault finding

Table 14 Fault finding

Condition
Pump does not start on page 53
Pump does not reach the ultimate pressure on page 53
Pumping speed is too low on page 54
After switching off the pump under vacuum, pressure in the system rises too fast on page 54
Pump gets too hot on page 54
Oil in the intake line or the vacuum vessel on page 55
Oil is turbid on page 55
Pump is excessively noisy on page 55
External oil leakage on page 56

Fault	Pump does not start
Cause	Wiring malfunction.
Remedy	Check and repair wiring.
Cause	Motor protection switch incorrectly set (three-phase motors only).
Remedy	Set motor protection switch properly.
Cause	Motor is malfunctioning.
Remedy	Replace the motor.
Cause	The operating voltage does not match that of the motor.
Remedy	Check whether the correct product number was booked. Adjust the voltage or replace the motor.
Cause	Oil temperature is below 10 °C (50 °F)
Remedy	Check the temperature with the team. Heat the pump and pump oil or use a different oil.
Cause	Oil is too viscous.
Remedy	Change the oil. Refer to Change the oil on page 45.
Cause	Pump is seized.
Remedy	Repair the pump. Contact Service.
Fault	Pump does not reach the ultimate pressure
Cause	Measuring technique or gauge is unsuitable.
Remedy	Use correct measuring technique and gauge. Measure the pressure directly at the intake port of the pump.
Cause	External leak
Remedy	Repair the pump. Contact Service.

Fault finding

Cause	The anti-suck back valve is malfunctioning.
Remedy	Repair the valve. Refer to Clean the intake port dirt-trap and anti-suck back valve on page 47.

Cause	Exhaust valve is malfunctioning.
--------------	---

Remedy	Repair the valve. Contact Service.
--------	------------------------------------

Cause	Oil is unsuitable.
--------------	---------------------------

Remedy	Change the oil (degas it, if necessary). Refer to Change the oil on page 45.
--------	--

Cause	Vacuum lines are dirty.
--------------	--------------------------------

Remedy	Clean the vacuum lines.
--------	-------------------------

Cause	Pump is too small.
--------------	---------------------------

Remedy	Check the process data, replace the pump if necessary.
--------	--

Fault Pumping speed is too low

Cause	The inlet screen in the intake port is clogged.
--------------	--

Remedy	Clean the dirt-trap. Install a dust filter in an intake line to prevent clogging. Refer to Clean the intake port dirt-trap and anti-suck back valve on page 47.
--------	---

Cause	Connecting lines are too narrow or too long.
--------------	---

Remedy	Use adequately wide and short connecting lines.
--------	---

Fault After switching off the pump under vacuum, pressure in the system rises too fast

Cause	System has a leak.
--------------	---------------------------

Remedy	Check the system.
--------	-------------------

Cause	Anti-suck back valve is malfunctioning.
--------------	--

Remedy	Repair the valve. Refer to Clean the intake port dirt-trap and anti-suck back valve on page 47
--------	--

Fault Pump gets too hot

Cause	Cooling air supply is obstructed.
--------------	--

Remedy	Set pump up correctly.
--------	------------------------

Cause	Ambient temperature is too high.
--------------	---

Remedy	Set pump up correctly. Refer to Table: Technical data .
--------	---

Cause	Process gas is too hot.
--------------	--------------------------------

Remedy	Change the process gas.
--------	-------------------------

Cause	Oil level is too low.
--------------	------------------------------

Remedy	Add oil to reach the correct oil level. Refer to Check the oil level on page 44.
--------	--

Fault finding

Cause Oil is unsuitable.
Remedy Change the oil. Refer to [Check the oil condition](#) on page 44.

Cause Oil cycle is obstructed.
Remedy Clean or repair the oil lines and channels.

Fault Oil in the intake line or the vacuum vessel

Cause Oil comes from the vacuum system.
Remedy Check the vacuum system.

Cause Anti-suck back valve is obstruction.
Remedy Clean or repair the valve. Refer to [Clean the intake port dirt-trap and anti-suck back valve](#) on page 47.

Cause Sealing surfaces of anti-suck back valve is damaged or dirty.
Remedy Clean or repair the inlet port and the anti-suck back valve. Refer to [Clean the intake port dirt-trap and anti-suck back valve](#) on page 47.

Cause Oil level is too high.
Remedy Drain the excess oil. Refer to [Check the oil level](#) on page 44.

Fault Oil is turbid

Cause Condensation
Remedy -Degas the oil or change the oil and clean the pump. Refer to [Change the oil](#) on page 45.
-To prevent condensation open the gas ballast valve or insert a condensate trap.

Fault Pump is excessively noisy

Cause Oil level is very low (Oil is no longer visible).
Remedy Add oil. Refer to [Check the oil level](#) on page 44.

Cause Silencing nozzle is clogged.
Remedy Clean or replace the silencing nozzle.

Cause Intake pressure is too high.
Remedy Lower the intake pressure.

Cause Coupling element is worn.
Remedy Install new coupling element. Refer to [Check the coupling and coupling element](#) on page 50.

Cause Vanes, bearings or other pump parts are damaged.
Remedy Repair the pump. Contact Service.

Fault finding

Fault	External oil leakage
Cause	Oil drain valve broken or thread loctite failed
Remedy	Replace the oil drain valve or re-loctite the thread.
Cause	Oil sight glass broken or sealing O-ring and gasket failed
Remedy	Replace the oil sight glass kit.
Cause	Oil casing sealing gasket failed or casing broken
Remedy	Replace the oil casing sealing gaskets or replace the oil casing.
Cause	Oil leakage at the shaft seals
Remedy	Replace the shaft seals.
Cause	Exhaust port blocked or the over-pressure valve thread loctite failed
Remedy	Clear the exhaust line or re-loctite the valve thread.
Cause	Plug seals failed or not fasten enough
Remedy	Replace the plug seals or fasten the plugs.

10 Storage

- Before the pump is shelved it must be properly disconnected from the vacuum system, purged with dry nitrogen and the oil must be changed.
- The inlet and exhaust ports of the pump must be sealed with the shipping seals which are provided upon delivery.
- The gas ballast switch must be set to the “0” position.
- If the pump is to be shelved for a longer period it must be sealed in a plastic bag containing desiccant (silica gel).
- When a pump is put into operation after it has been shelved for over one year, standard maintenance of the pump must be done and the oil must also be changed (refer to [Change the oil](#) on page 45). We recommend that you contact us.
- Store the pump in a dry place at room temperature until the pump is put back into service again.
 - Storage temperature: -15 °C ~ 70°C
 - Storage humidity: less than 80% RH

Disposal

11 Disposal

Dispose of the pump, the oil and any components removed from the pump safely in accordance with all local and national safety and environmental requirements.

Particular care must be taken with components and waste oil that have been contaminated with dangerous process substances.

12 Accessories

Table 15 Accessories

Part description	Part number
Exhaust oil mist filter	1019040A20
Exhaust oil mist filter heavy version	1019090A20
Permanent GB kit with KF16 connection	1019040A40
EM GB kit with KF16	1019040A41
Thermal switch	1019040A70
Roots adapter	1019040A60

The stability of the pump is ensured with accessories supplied by us. Mounting of any other accessory will engage the responsibility of the user concerning the stability of the pump.

In case a direct roots pump coupling is used, it is important to check the gas temperature due to the roots compression.

13 Legal declarations



Pioneering products. Passionately applied.

Leybold GmbH
Bonner Strasse 498
50968 Cologne
GERMANY
+49-(0)221-347-0
info@leybold.com
www.leybold.com