



工业冷水机操作手册

Focus on R&D, Production and sales of industrial refrigeration equipment

专注于工业制冷设备的研发、生产与销售



Foreword

Dear customer, thank you for purchasing our industrial chiller.

Thank you for your trust and support of our brand.

Our company will continue to uphold international high-standard design and high-quality service requirements.

Our mission is to be based in China, with a global perspective, and dedicated to providing users with comprehensive and warm services.

Control equipment and temperature system solutions. Our company adheres to the principle of seeking innovation through technology.

We seek development through quality, build our brand through integrity, and establish our foundation through focus. We sincerely hope to cooperate with all...

Let us join hands with friends from all walks of life to develop together and create a brilliant future.

1. This manual is intended to explain how to operate and use this chiller, and to provide you with...

This document provides precautions for routine maintenance and methods for handling potential problems and malfunctions.

2. In order to use this equipment effectively and safely, operators are requested to read the instructions carefully.

This manual.

3. If you have any questions, please call our after-sales service hotline, where professional technicians will assist you.

Our staff will answer your questions.

目 录

Table of contents

Preface.....	1
Chapter 1 Safety and Precautions.....	3
Chapter Two: Outline Drawings and Component Introduction.....	4
Chapter 3 Refrigeration System Schematic Diagram.....	5
Chapter 4 Installation and System Application.....	7
Chapter 5 Operating Instructions.....	10
Chapter Six: Troubleshooting and Operation.....	14

Thank you for purchasing our industrial chiller unit. Please read this instruction manual carefully before installing and using the unit.

The book should be kept safe and accessible for future reference.

Good operating habits can improve the unit's working efficiency and effectively extend its service life. Please follow these guidelines.

Fan used the chiller unit.

Chapter 1 Safety and Precautions

1-1 Please ensure that the power supply type introduced on site is compatible with the ordered unit. The specific power supply type can be specified.

To check the crew's nameplates, Domestically, the standard is typically 380V-50Hz-3PH or

A 220V, 50Hz, 1PH AC power supply is required; an incorrect power supply may cause damage to the unit or even operational issues.

Personnel casualties! If other power supply requirements exist, they must be specifically addressed before ordering the unit.

Note: If you have already placed an order, please contact our technical department for a solution!

1-2 The voltage used by the generator unit must be within $\pm 10\%$ of the rated voltage. Voltages that are too high or too low will result in a loss.

All of these could cause damage to the unit;

1-3 The cables and wires introduced into the generating unit must be products that meet national standards; the cables and wires

The specifications must meet the maximum operating current of the unit. The unit current rating can be found in Chapter 3.

The Technical Specifications Table;

1-4 When the unit's circuits require maintenance, the power supply must be disconnected before opening the control cabinet, and this must be done by a specialist.

Professionals will operate the equipment;

Units 1-5 have been pre-filled with refrigerant before leaving the factory. After a period of use, the customer must manually add refrigerant.

When adding refrigerant, you must add the same type of refrigerant as indicated on the unit's nameplate; otherwise, add...

Adding the wrong refrigerant will directly cause irreparable and severe damage to the compressor;

1-6 Before using the unit, ensure that the air intake and exhaust are good, or that the water intake and outlet are unobstructed;

The air inlet of the refrigeration unit must be free of obstructions within 50cm, and the exhaust outlet direction must be correct.

1-7 The environmental conditions for use must meet the requirements of the unit. The ambient temperature for air-cooled units is -5 to 43°;

The cooling water inlet temperature of the water-cooled unit is 10–33°;

1-8 Antifreeze must be added to the refrigeration side of the cryogenic unit. The type of antifreeze must be compatible with the unit ordered.

The timing requirements must be consistent to avoid affecting the service life of the unit due to corrosion; and the antifreeze concentration must be...

To meet the requirements specified in Chapter 3, "Technical Parameter Table," to prevent the heat exchanger and piping from freezing and cracking.

1-9 The chiller unit is an industrial product. Please operate it according to regulations and avoid frequent switching on and off.

Chapter Two: Exterior Drawings and Component Introduction

2-1 Air-cooled chiller unit

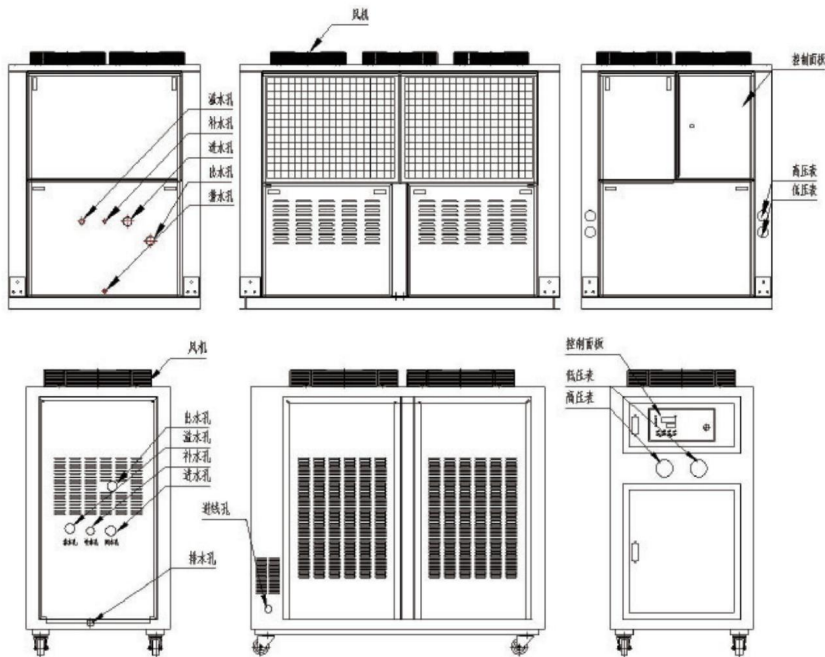

2-2 Water-cooled chiller unit

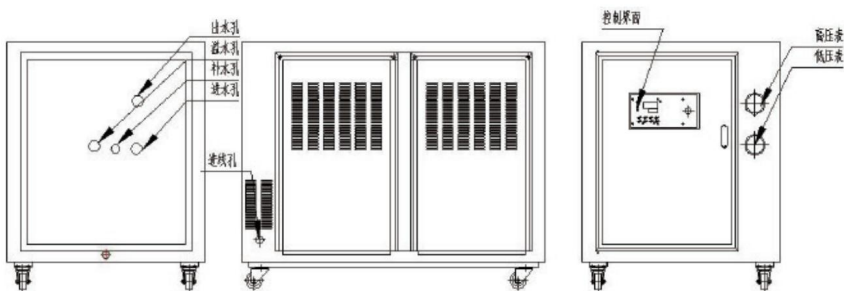

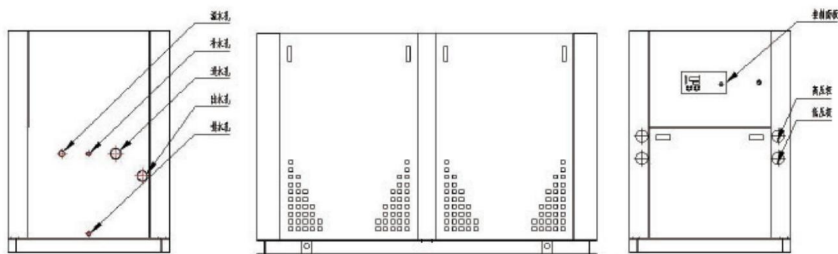

The piping shown in the diagram is for illustrative purposes only. Depending on the type of generator unit, the piping may differ from the diagram above.

The actual product markings shall prevail.

2-3 Main Components

2-3-1 Compressor: The scroll compressor unit adopts a fully enclosed flexible scroll compressor from an internationally renowned brand.

The axial and radial rotation of the rotating disc adopts a flexible design, the compressor is equipped with a built-in protector, and the independent modular design ensures practicality.

The current capacity allows for flexible combinations, making it convenient to use and highly reliable. The low-temperature model uses a dedicated compressor with a thickened scroll plate.

Special design for oil separation.

2-3-2 Heat Exchanger: The condenser of the air-cooled unit adopts a high-efficiency heat exchanger with hydrophilic aluminum foil sleeves and internally threaded copper tubes.

The heat exchanger has good heat transfer performance; the water-cooled chiller unit uses a high-efficiency horizontal shell-and-tube heat exchanger; the evaporator has high efficiency.

Stainless steel plate heat exchangers and dry shell-and-tube evaporators are available, offering high efficiency and energy savings.

2-3-3 Throttling Device: The throttling device uses products from European and American brands, ensuring reliable performance and accurate control.

It can also be equipped with an electronic expansion valve with European and American display for more precise control and high energy efficiency.

2-3-4 Water Pump: The built-in stainless steel water pump is from a well-known domestic brand, ensuring stable performance; the bearings are from an imported brand.

It features low vibration and noise, and the mechanical seal ensures that the shaft will not be damaged and there will be no water leakage.

2-3-5 Electrical Components: All electrical components are from internationally renowned brands, with a mechanical life of over one million cycles.

The intelligent, high-precision controller ensures the safe operation of the unit; it provides accurate control and high energy efficiency.

2-3-6 Sheet metal casing: electrostatic spraying, outdoor-grade metal powder, beautiful and durable.

Chapter 3 Refrigeration System Schematic Diagram

The refrigeration system of a box-type chiller unit is a reverse Carnot cycle vapor compression cycle system; see the diagram below.

This is a refrigerant cycle diagram (for reference only). Due to variations in machine models, types, and customer requirements, the actual product may differ.

The components and piping arrangements may differ from those shown in the diagram below; please refer to the actual piping configuration.

The refrigeration system diagram below only shows a single refrigeration system. For models with two or more units, only the water tank is shared, and the refrigerant is...

They are independent of each other, and the two systems are completely identical.

3-1 Working principle diagram of air-cooled box-type water chiller unit

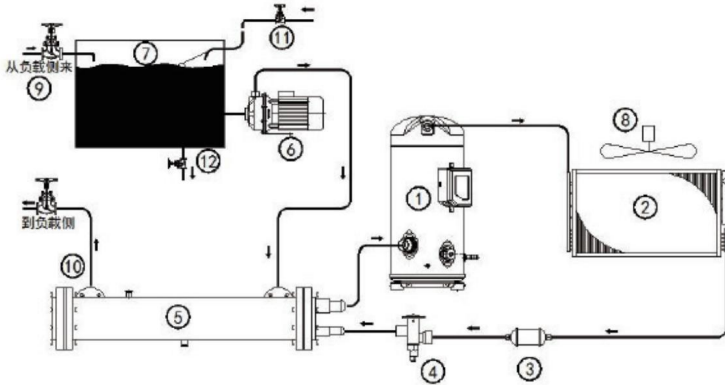

Description:

1. Compressor 2. Finned Condenser 3. Dryer Filter 4. Thermal Expansion Valve 5. Dry Evaporator 6. Stainless Steel Water Pump 7. Water Tank 8. Axial Flow Fan
9. Chilled Water Return Port 10. Chilled Water Outlet 11. Water Tank Inlet 12. Water Tank Drain Port

3-2 Working principle diagram of water-cooled box-type chiller unit

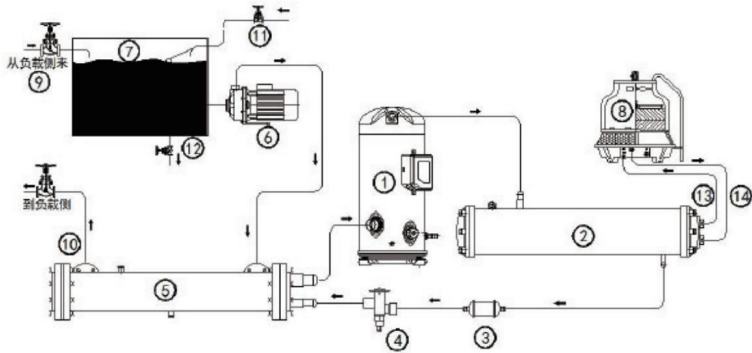

Description:

1. Compressor 2. Shell and tube condenser 3. Dry filter 4. Thermal expansion valve 5. Dry evaporator 6. Stainless steel water pump 7. Water tank 8. Cooling tower 9. Chilled water return port 10. Chilled water outlet 11. Water tank inlet 12. Water tank drain 13. Cooling water outlet 14. Cooling water inlet.

Chapter 4 Installation and System Application

4-1 Selection of Installation Location

Box-type water chiller units are suitable for installation inside rainproof canopies or indoors with good ventilation.

The space in the exhaust direction of the chiller unit must not be less than 2.0m, so that the chiller can be ventilated by the cooling fan during refrigeration operation.

The hot air emitted from the chiller should be dissipated into the external environment. There should be a 1.5-2m space in the direction of the condenser intake on the side of the chiller.

Ensure a suitable working environment for the chiller. The unit must be installed on a solid, level concrete base with a depth of at least 20cm.

In addition, for units with a capacity of 10HP or higher, vibration damping devices should be installed and secured with anchor bolts; a certain amount of clearance should be left around the unit.

The workspace is designed to facilitate operation, inspection, and maintenance.

Box-type water chillers require an ambient temperature of -5y to 43y and a relative humidity of no more than 80%.

4-1-1 Installation Space Requirements for Air-Cooled Box-Type Chillers

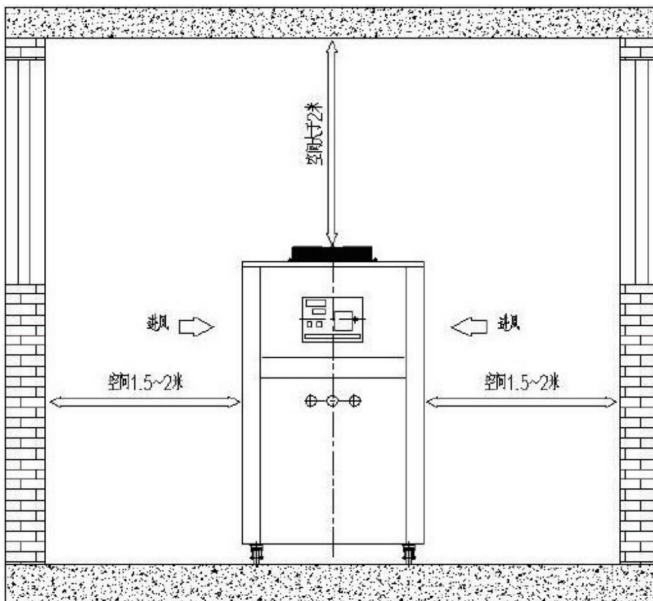

4-1-2 Installation Space Requirements for Water-Cooled Box-Type Chillers

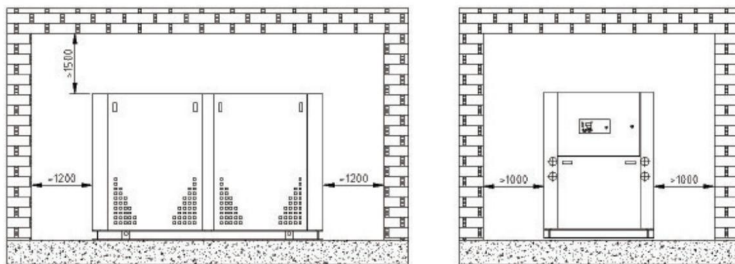

4-2 Air duct

If an air-cooled unit is installed in an indoor computer room, and the room has poor ventilation, an air duct should be added to reduce airflow.

The hot air exhausted by the unit is vented outdoors. The diagram below is for reference only:

The static pressure of the axial flow fan in an air-cooled box-type water chiller is almost 0 Pa. If the air supply duct is long...

If the duct is 1 meter wide, an exhaust fan must be added to the duct; otherwise, poor ventilation will cause the unit to malfunction.

It works perfectly!

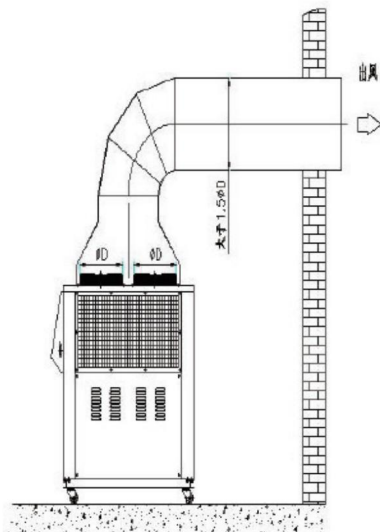

4-3 Water Piping System Installation

Our standard box-type units are available in three configurations, both air-cooled and water-cooled, including those with built-in water tanks and pumps, and those with built-in...

Water tanks are available without water pumps, and units without built-in water tanks and water pumps are also available for order. Different structural types of units typically have different specifications.

The water system piping design can be referenced in the following diagram:

4-3-1 Air-cooled with built-in water tank and water pump

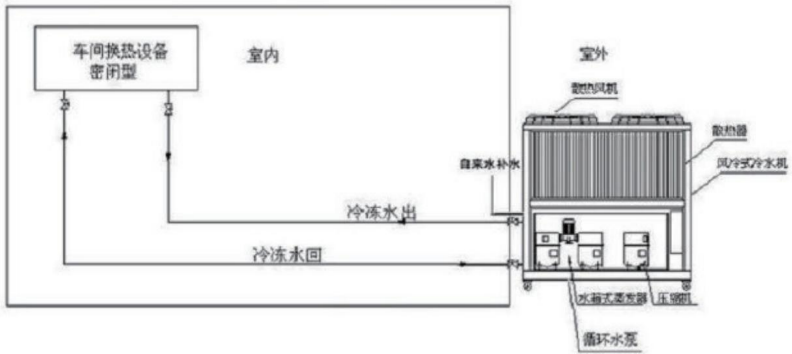

4-3-2 Air-cooled shell-and-tube external water tank

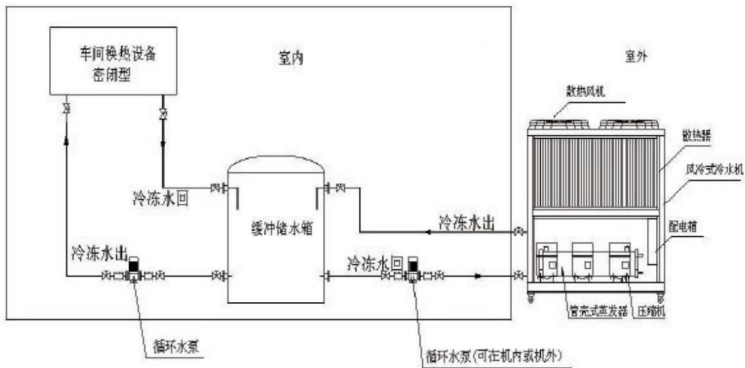

4-3-3 Water cooling system includes built-in water tank and water pump

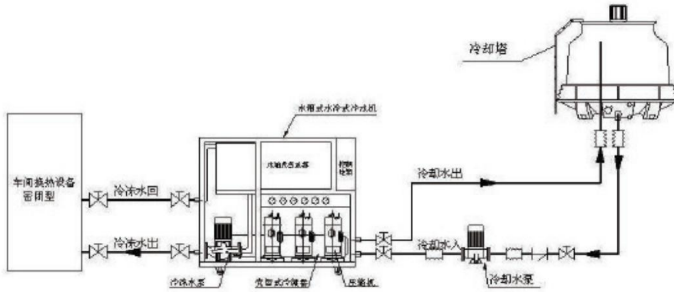

4-3-4 Water-cooled shell-and-tube external water tank

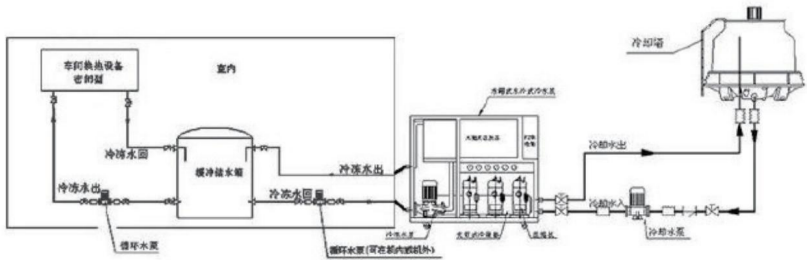

Chapter 5 Operating Instructions

5-1 Specifications:

Serial Number	Specifications	Specifications
1	Rated input voltage	220-250VAC 50/60HZ
2	Temperature measurement range	-40~100y
3	Measurement accuracy	0.1y@25y
4	Work environment	-10y~60y, y85%RH, non-condensing
5	Storage environment	-20y~70y, y85%RH, non-condensing
6	Switch output	5 relays 250VAC 2A

7	Relay load type	D01: Alarm
8	digital input	D 10 22 - D None 05 Source: Signal input/valve
9	Analog input	1-channel NTC temperature probe
10	Current input	4-channel current (0.3–35A)

5-2 Panel Diagram

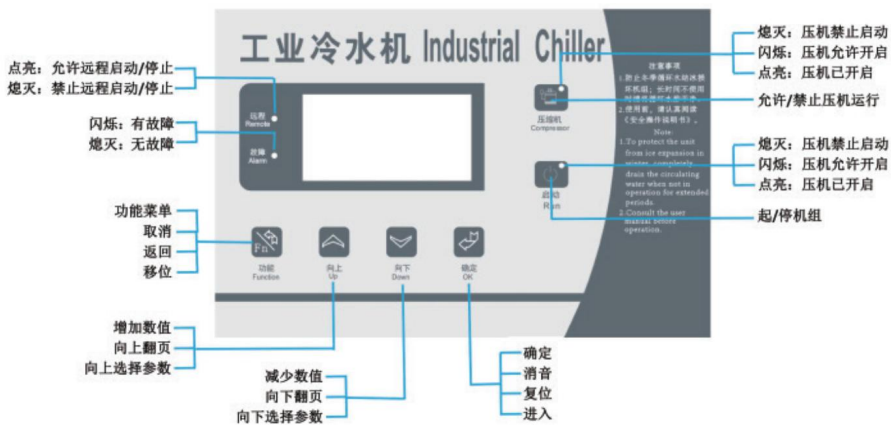

5-3 First Power On

The controller requires configuration upon initial power-on. This configuration is pre-configured at the factory and is not necessary unless specifically requested by the user.

No additional configuration is required during operation to avoid unit malfunction; however, if reconfiguration is necessary for special reasons, [further configuration may be required].

Please refer to the configuration wizard below.

5-4 Commonly Used Interfaces

The commonly used interfaces include the main interface and the alarm interface.

5-5 Controller Troubleshooting

Fault Name	Detection Condition	Compressor Status	Troubleshooting	Solution
#1 compressor high pressure	Indicator Flashing Or detect when it is lit			
#1 compressor low pressure	If the [low voltage detection delay] is 0, the compressor status indicator light is flashing. Detection when it flashes or lights up; if [Low-voltage detection delay] is not... 0, #1 compressor operation test		Only stop compressor #1, it will not affect Other equipment working [Note 1]	Check if the input matches the switch setting. To

#1 compressor overload	#1 Compressor Operation Detection		Check if the input matches the switch setting. Check if the compressor's rated
#1 Compressor current too high			current setting is reasonable.
#1 Compressor current too low			Check if the compressor current wiring is correct and the interface is secure. Check if the input is consistent
#1 Exhaust temperature too high			with the switch setting.
#2 compressor high pressure	When the compressor status indicator light flashes or illuminates, if the [Low	Only shut down compressor #2; this will not affect the operation of other equipment. [Note 2]	Check if the input matches the switch setting.
#2 compressor low pressure	Pressure Detection Delay] is 0, the compressor status indicator light will flash or illuminate; if the [Low Pressure Detection Delay] is not 0, the #2 compressor will be running and detected.		
#2 compressor overload	#2 Compressor Operation Detection	Only shut down compressor #2; this will not affect the operation of other equipment. [Note 2]	Check if the input matches the switch setting; check if the compressor rated
#2 Compressor current too high; #2			current setting is reasonable; check if the compressor current wiring is correct
Compressor current too low; #2			and the interface is secure; check if the input matches the switch setting.
Exhaust temperature too high			
Too low temperature	Runtime detection	If the compressor, cooling pump, and refrigeration pump are stopped but not stopped	The outlet water temperature is lower than the set low temperature protection temperature.
Over-temperature warning		after a delay, the system will only alarm and will not affect the	The outlet water temperature is higher than the over-temperature warning temperature.
Over-temperature shutdown		operating equipment. If the "Over-temperature alarm handling" is set to "Do not stop refrigeration pump", the compressor, cooling pump, and refrigeration pump will stop but not stop. If the "Over-temperature alarm handling" is set to "Stop refrigeration pump", the entire unit will be stopped.	The outlet water temperature is higher than the set high temperature protection temperature.
Antifreeze failure	Power-on test	The compressor stops, the cooling pump stops after a delay, and the refrigeration pump continues running	Check if the antifreeze input is consistent with the switch setting.
Temperature probe open circuit;			Check if the temperature probe is making good contact.
temperature probe short circuit			
Cooling overload [Note 3]	After the cooling pump starts, the compressor and cooling pump are stopped, while the refrigeration pump continues to operate.		Check if the cooling overload input matches the switch setting; check if the cooling pump rated
Cooling circuit too high			current setting is reasonable; check if the cooling pump current wiring is correct
Cooling current too low			and the interface is secure; check if the cooling water flow input matches the switch setting.
Cooling water flow failure, cooling pump start-up [cooling start]			

	Dynamic delay detection after time.		Consistent quantity settings
chilled water flow failure	Refrigeration pump start [Refrigeration start] Dynamic delay detection after time.	If [Insufficient water flow handling] is set The cause of the "water pump failure" is... Unit shutdown in case of failure; If [Insufficient water flow handling] is set For "uninterrupted water pumping", an incident occurred In case of failure, stop the compressor and cooling system. The pump, the refrigeration pump, keeps running.	Check if the water flow input matches the switch setting. Set consistent
Freezing overload [Note 3]	Refrigeration pump start-up test	Shutdown unit	Check if the refrigeration overload input is related to the switch. Consistent quantity settings
Excessive freezing current			Check if the rated current setting of the chilled pump is correct. Reasonable
Low freezing current			Check if the chilled pump current wiring is correct. Indeed, is the interface secure?
Three-phase power supply fault	Power-on test	Shutdown unit	Check if the three-phase input is missing a phase or reversed. Phase: are the switching quantities correct?
Water level failure	Power-on test	If [Low Water Level Handling] is set to "Water pump stopped" - malfunction. Timely shutdown unit; If [Low Water Level Handling] is set to "Water pump not stopping" caused an accident. In case of failure, the compressor and cooling pump will be stopped. The refrigeration pump keeps running.	Check if the water level input matches the switch setting. Set consistent
The unit needs maintenance.	Runtime detection	The unit cannot be restarted once it has stopped (if the cumulative running time of the compressor exceeds the set limit). value)	
#1 compressor oil pressure too low	Compressor operation detection	Stop the compressor, delay the shutdown of the cooling pump.	Check if the hydraulic switch input matches the switch.
#2 compressor oil pressure too low		The chiller pump keeps running	Consistent quantity settings

①Note 1): If the [Low-pressure pump stop delay] is not 0, and a "#1 compressor low pressure" fault occurs, the fault handling solution is as follows:

Immediately stop all compressors and cooling pumps, and then stop the refrigeration pump after a delay of the [low pressure pump shutdown delay] time. If the [low pressure pump shutdown delay] is...

If the value is 0, the troubleshooting solution is to stop only compressor #1 without affecting the operation of other equipment.

[Note 2]: The troubleshooting for a "low pressure on compressor #2" fault is similar to that for a "low pressure on compressor #1" fault.

The parameter related to "Low-pressure pump shutdown delay" is relevant.

[Note 3]: The following table displays overload and cooling fault information for different models:

Air-cooled	Refrigeration overload display information:	Cooling overload display information
and water-cooled models	refrigeration pump overload	Cooling fan overload
Water-cooled cold water	Refrigeration pump overload	Cooling pump overload
cold wind	blower overload	Cooling fan overload
Water-cooled air	blower overload	Cooling pump overload

5-6 Manufacturer's Parameter Table

The parameters set by the manufacturer and their meanings are shown in the table below. (Items marked with "" are configuration wizard parameters)

①Note 1): Remote switch. When using remote control, closing the remote switch input will start the unit and remotely control the generator.

If the input of the program switch is disconnected, the unit will stop.

Chapter Six: Troubleshooting and Operation

6-1 Troubleshooting

The common faults and troubleshooting methods listed below are for reference only and do not include all possible faults.

For any fault symptoms not mentioned or uncertain in the table, please contact our after-sales service department.

Fault	Possible reasons	Elimination methods
The unit fails to start or stops immediately after starting.	1. Power failure or low voltage. 2. Improper temperature controller settings causing the contacts to remain open. 3. Overload protection failed to reset after activation.	1. Troubleshoot the circuit and power on the unit as required. 2. Readjust the temperature control setting. 3. Press the overload protection reset button.
High voltage during unit operation	1. Excessive scale buildup on condenser copper tubes results in poor heat exchange. 2. Too much refrigerant. 3. Expansion valve opening is too small.	1. Clean the condenser. 2. Discharge some of the refrigerant. 3. Adjust the opening degree of the expansion valve appropriately.
Low pressure during unit operation	1. Insufficient refrigerant. 2. Clogged filter. 3. Expansion valve opening too small	1. Check for leaks, add refrigerant, or adjust the expansion valve. 2. Clean or replace the filter. 3. Adjust the expansion valve opening appropriately.
Frost buildup on return pipe and compressor casing	1. Expansion valve opening too large. 2. Too much refrigerant. 3. Insufficient heat load.	1. Adjust the expansion valve. 2. Release some refrigerant. 3. Increase the heat load.
The chilled water pump is not pumping water.	1. Water pump reverses direction. 2. Impeller clogged.	1. Correct the rotation direction of the water pump motor. 2. Clean the water pump impeller.
Insufficient water pump flow	1. Impeller or water pipe is blocked. 2. Impeller is damaged.	1. Clean the impeller or water pipe. 2. Replace the impeller.

6-2 Component Operation and Use

When a fault occurs, after understanding the fault details from the controller interface, it may be necessary to determine some practical issues on-site.

In some cases, manual intervention is required to proceed with troubleshooting.

6-2-1 Reading high and low pressure gauge values: The high and low pressure of the refrigerant are important indicators of the unit's operation.

In daily operations, customers should keep daily records;

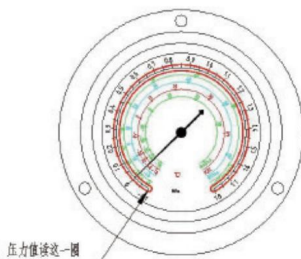

Low pressure gauge

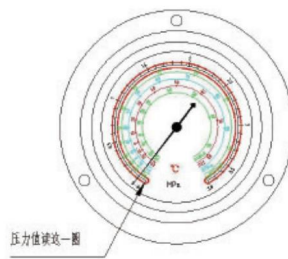

High pressure gauge

Read the high and low pressure gauges as indicated in the diagram above. The units in the table are in MPa (International Standard Unit).

In common use, the engineering unit kg/cm² is commonly used; 1MPa = 10bar ≈ 10kg/cm²; different operating conditions for different units

The working pressure range can be found in the table below:

Model	content	Working pressure range (bar)			
		Water output at 7y	water output at -5y	water output at -15y	-35y water output
water chiller Group	High voltage upper	16.0	16.0	16.0	16.0
	limit, high voltage	12.0	10.0	10.0	9.0
	lower limit, low	6.0	4.9	4.0	3.2
	voltage upper limit,	3.0	1.8	0.9	0.05
air-cooled machine Group	low voltage lower limit, high voltage upper limit 20.0		20.0	20.0	20.0
	Lower limit of high voltage: 14.0		12.0	12.0	11.0
	Low pressure upper limit	6.0	4.9	4.0	3.2
	Low voltage lower limit	3.0	1.8	0.9	0.05

6-2-2 High and Low Pressure Controller: When the compressor is working, the high and low pressure must operate within the normal range.

Exceeding the operating range may damage the compressor or even cause a safety accident. To ensure the normal operation of the unit...

During operation, each generator unit is equipped with a high and low voltage controller (switch); when the allowable set value is exceeded, the high and low voltage controller...

When the device generates an action, the controller will issue a fault alarm and stop the machine.

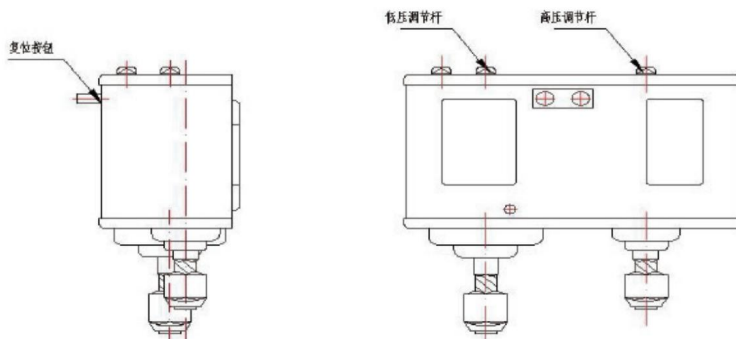

The left side of the high/low voltage controller is for low voltage, and the right side is for high voltage. When a fault occurs, the relay inside the controller...

The device generates a switching signal and sends it to the controller; when the fault is cleared, the low-voltage side will automatically reset, while the high-voltage side will...

The side requires manual intervention to reset. There is a reset button at the location shown in the diagram. After the high-voltage fault is cleared, use...

Press this button once; a click indicates that it has been reset. If you cannot press it or do not hear a sound, proceed with the reset.

The fault may not have been eliminated, preventing the reset.

The protection values for the high and low voltage controllers are set by adjusting the two bolts on top; these settings are pre-defined at the factory.

Based on the default settings, it is recommended that users do not easily change these two settings during use. If adjustments are necessary, they must be made in accordance with the instructions.

We have made contact with our technical department:

The factory default values for high and low voltage controllers are shown in the table below:

Model	content	Setting value (bar)			
		Water output at 7y,	water output at -5y,	water output at -15y	-35y water output
Water-cooled units	High voltage protection	18bar	18bar	18bar	18bar
Air-cooled units (air-cooled/water-cooled)		23bar	23bar	23bar	23bar
unit	Low voltage protection	3.2 bar	2.0 bar	1.1 bar	-0.2 bar
	Range of motion	1.5 bar	1.5 bar	1.5 bar	1.5 bar

6-2-3 Thermal Overload Relay Some units are equipped with thermal overload relays, which are installed below the contactor.

Used to protect motor equipment from current exceeding the allowable range. When the current exceeds the allowable set value, the thermal overload relay generates...

If the system malfunctions, the controller will issue a fault alarm and shut down the machine; depending on the model, it may be equipped with multiple thermal overload relays.

For specific corresponding devices, please refer to the circuit diagram.

Our company may equip thermal relays with either the LS brand or Schneider brand; when an overload occurs, the thermal relay...

The device generates a switching signal that is sent to the controller. When restarting is required, the thermal relay must be reset first.

The reset button for the thermal relay is shown in the image below.

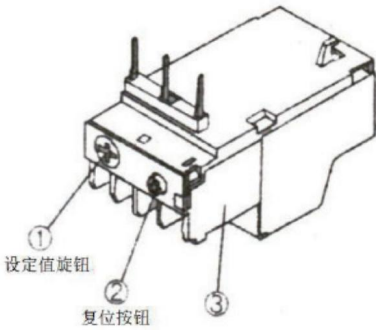

LS thermal relay

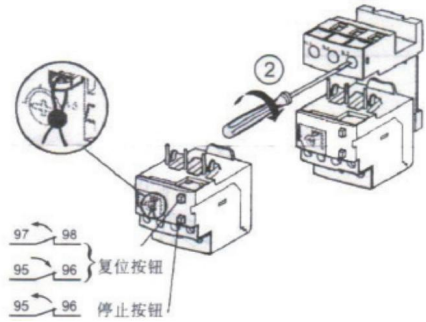

Schneider Thermal Relays

