



**MEISONIC**

---

**Company Address:**

江苏省苏州市昆山市北门路2211号

No. 2211 Beimen Road, Kunshan City, Suzhou City, Jiangsu Province

**Tel:** 0512-8689968

<https://www.meisonic.com/>

---

One stop procurement platform for industrial display brackets  
We specialize in providing research and development, design, customization, and production services



MEISONIC



# MEISONIC

## Product Catalogue

Collaboration. Win.Create  
2025版

# COMPANY PROFILE

---

## Engineering Capability

Professional research and development and engineering team to support and serve the needs of the customers.

## Production Capacity

We serve original equipment manufacturers, institutional and industrial customers, own plants, and manufacturers.

## Quality Assurance

As an ISO 9001:2000 certified manufacturer, we have implemented total quality management From raw material inspection, production process control, to final inspection and packaging.





## MEISONIC Professional Display Mount Solutions Provider

Meisonic Technology Co., Ltd., established in year 2012, is a high-tech enterprise specializing in the research, development, production, and sales of industrial equipment monitor mounts and medical equipment monitor mounts. With 13 years of industry experience, we are committed to providing customers with high-quality, high-performance display mount products and one-stop solutions.

### Our Advantages:

**Extensive Industry Experience:** 13 years of deep expertise in the monitor mount field, with a profound understanding of customer needs, enabling us to provide professional product recommendations and solutions.

**Strong R&D Capabilities:** A seasoned R&D team capable of customizing designs and production based on customers' specific requirements.

**Comprehensive Production System:** Equipped with advanced production facilities and a strict quality control system to ensure stable and reliable product quality.

**Excellent After-Sales Service:** Providing comprehensive pre-sales, in-sales, and after-sales services to promptly address customer issues and protect their rights.

### Our Services:

**Product Customization:** Offering customization services in size, material, and functionality based on customer needs.

**Solution Design:** Providing professional monitor mount installation solutions, including mount selection, installation positioning, and wiring design.

Backed by strict quality control and dedicated project management, they guarantee full-cycle support. Post-installation, certified engineers provide 24/7 technical assistance via multiple channels, ensuring rapid troubleshooting and system optimization. MEISONIC combines innovation, reliability, and comprehensive service to meet diverse client needs globally.





## Workshop

We have an excellent production team and production line to ensure product quality and production efficiency.



## Advanced production equipment

We have advanced equipment such as laser cutting machines, welding machines, and fully automatic CNC bending machines.



## Packaging warehouse

Centralized process from production to packaging to ensure product quality.



# Certificate of Honor

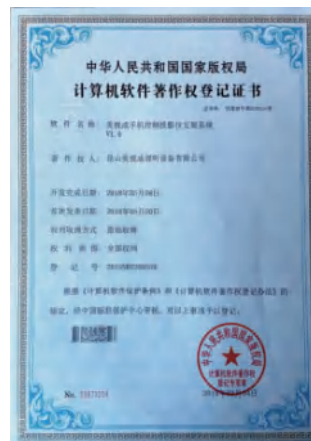
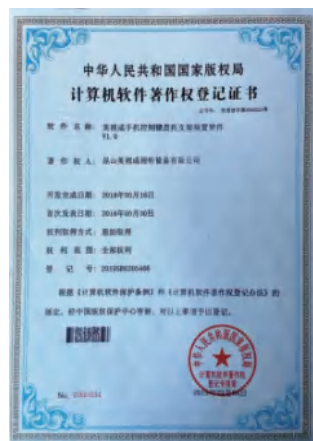









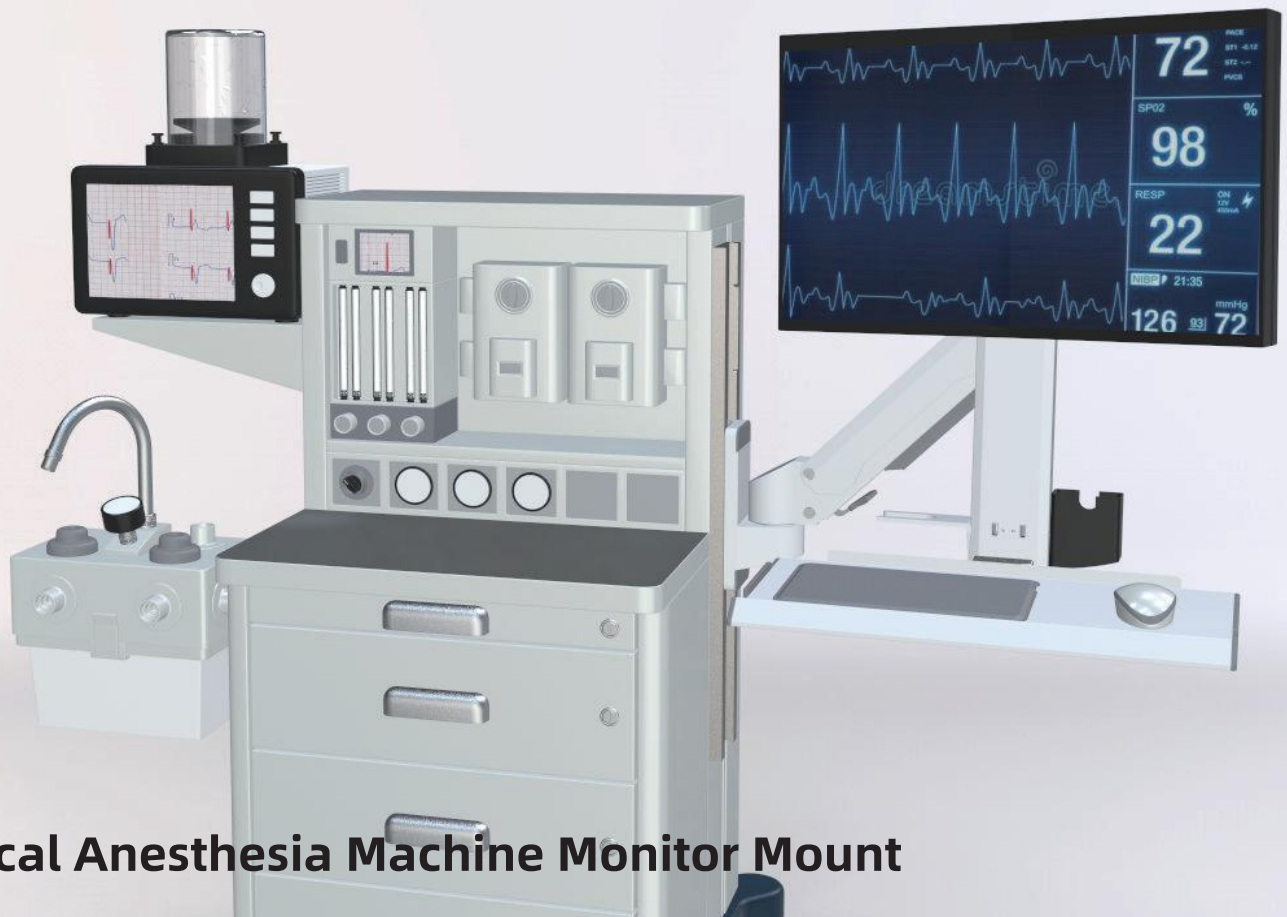

## Medical Anesthesia Machine Monitor Mount



The joint is equipped with a flat bearing, which makes the rotation more silky and does not hold









Air pressure can be adjusted manually without tools

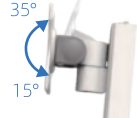

Full of materials, two-layer design



PRODUCT NO: T8-GA01KB  ≤25kg

VESA	Tilt	Rotate	Swivel
100x100 75x75mm 	35° 15° 	360° 	180° 180° 
Cable Management	Height Adjust	Air Pressure Rise and Fall	Quick Installation Design
	65mm 	315mm 	

## Dimensions

Unit: mm

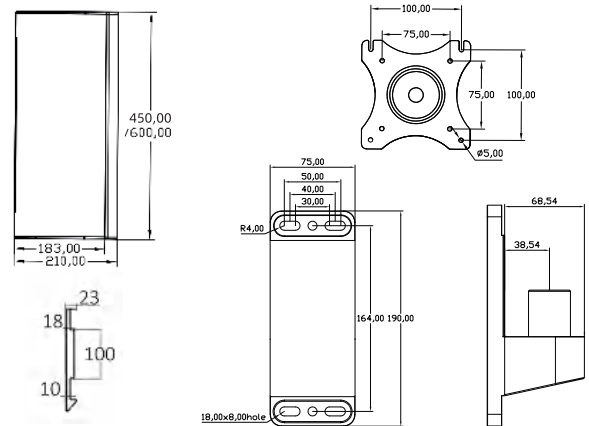
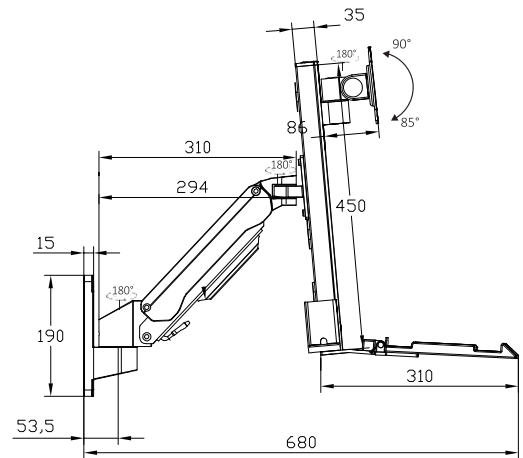

## Specifications

Complete System	Net Weight	≈7kg (≈15.43lbs)	
	Colour	Black/White/Silver	
	Material	Plastic/Aluminum	
Display System	Hinge Module	Swivel (VESA Hinge)	±90°
		Tilt (VESA Hinge)	-15° ~ + 35°
		Tilt (Keyboard)	0 ~ 90°
		Pivot	180°
		User Torque Adjust	Available
	Display Support	Mounting Pattern	100x100 / 75x75 mm
		Display Type	Singal Monitor
		Panel Size Support	≤32"
		Support Weight (VESA)	≤10kg (≤22lbs)
	Height Adjust	Support Weight (Keyboard)	≤3kg(≤6.61lbs)
		Height Adjustment Range	65mm(2.55") / 315mm(12.40")
		(Monitor) / (Arm)	
		Tension Torque Adjust	Yes
Extended Arm Provided		1	
Cable Management		Yes	
	Tilt (Profile)	6°	

## Ordering Information

Product No.	KeyBoard Tray Size	Product Description
T8-GA01KB (Color Remarks)	450mm or 600mm (Note Remarks)	Workstation, support 32", ≤25kg, single Arm with Keyboard tray, 75x75 / 100 x 100 mm

All product specifications are subject to change without notice

Last updated: 13-Apr-2025





PRODUCT NO: T8-GA02KB

≤25kg

<b>VESA</b> 100x100 75x75mm 	<b>Tilt</b> 35° 15° 	<b>Rotate</b> 360° 	<b>Swivel</b> 180° 180° 180° 
<b>Cable Management</b> 	<b>Height Adjust</b> 65mm 	<b>Air Pressure Rise and Fall</b> 315mm 	<b>Quick Installation Design</b> 

**Dimensions**

Unit: mm

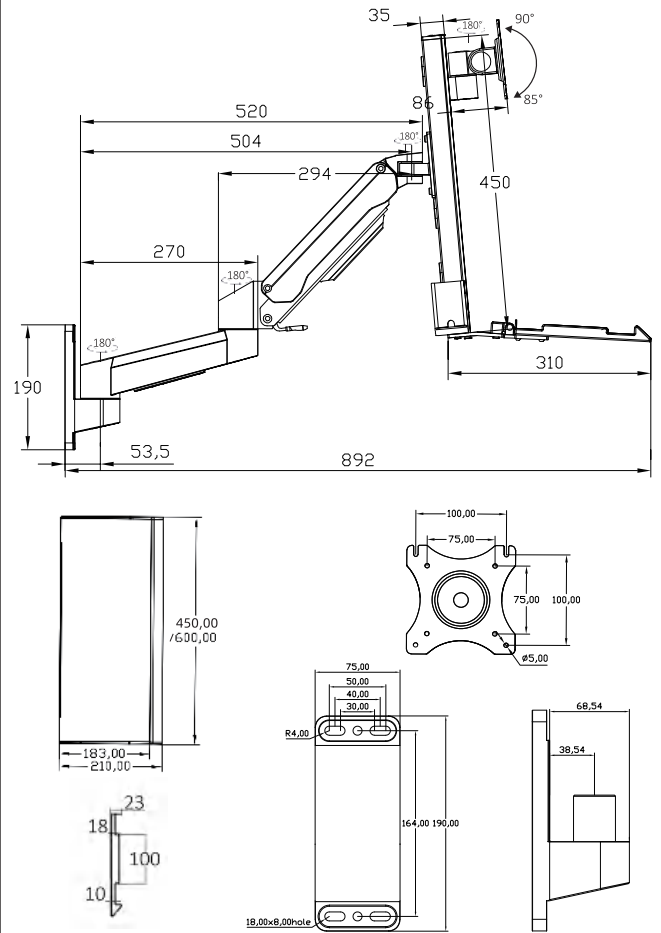

**Specifications**

Complete System	Net Weight	≈8kg (≈17.63lbs)	
	Colour	Black/White/Silver	
	Material	Plastic/Aluminum	
Display System	Hinge Module	Swivel (VESA Hinge)	±90°
		Tilt (VESA Hinge)	-15° ~ + 35°
		Tilt (Keyboard)	0 ~ 90°
		Pivot	180°
		User Torque Adjust	Available
	Display Support	Mounting Pattern	100x100 / 75x75 mm
		Display Type	Singal Monitor
		Panel Size Support	≤32"
		Support Weight (VESA)	≤10kg (≤22lbs)
		Support Weight (Keyboard)	≤3kg(≤6.61lbs)
Height Adjust	Height Adjustment Range (Monitor) / (Arm)	65mm(2.55") / 315mm(12.40")	
	Tension Torque Adjust	Yes	
	Tilt (Profile)	6°	
Extended Arm Provided		2	
Cable Management		Yes	

**Ordering Information**

Product No.	KeyBoard Tray Size	Product Description
T8-GA02KB (Color Remarks)	450mm or 600mm (Note Remarks)	Workstation,support 32",≤25kg, Arm with keyboard tray,75x75 / 100 x 100 mm

All product specifications are subject to change without notice

Last updated: 13-Apr-2025



PRODUCT NO: T9-GA01KB

≤25kg

VESA	Tilt	Rotate	Swivel
100x100 75x75mm 	35° 15° 	360° 	180° 180° 
Cable Management	Height Adjust	Air Pressure Rise and Fall	Quick Installation Design
	65mm 	315mm 	

## Dimensions

Unit: mm

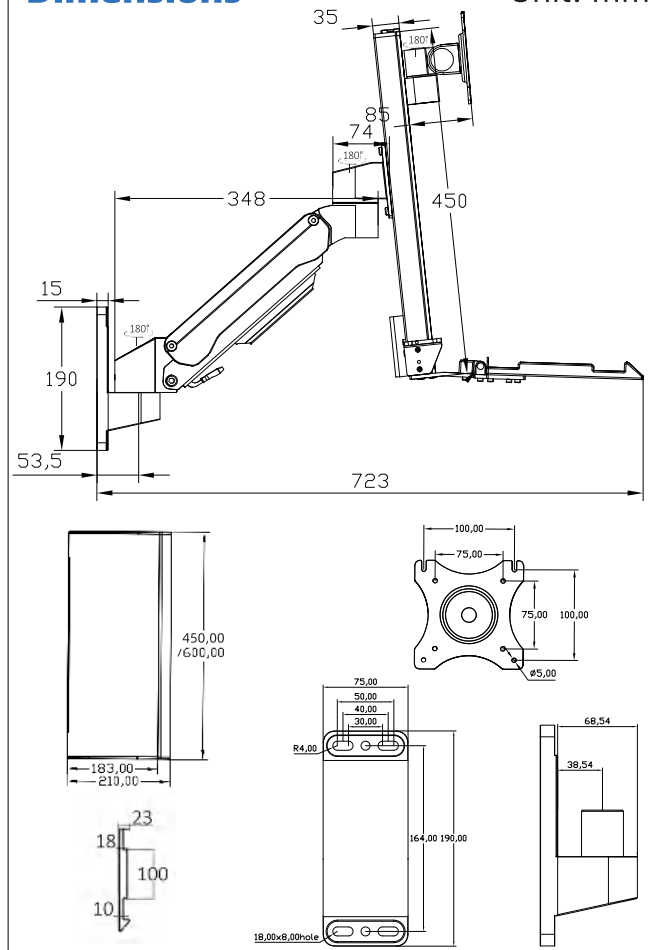

## Specifications

Complete System	Net Weight	≈7kg (≈15.43lbs)	
	Colour	Black/White/Silver	
	Material	Plastic/Aluminum	
Display System	Hinge Module	Swivel (VESA Hinge)	±90°
		Tilt (VESA Hinge)	-15° ~ + 35°
		Tilt (Keyboard)	0 ~ 90°
		Pivot	180°
		User Torque Adjust	Available
	Display Support	Mounting Pattern	100x100 / 75x75 mm
		Display Type	Singal Monitor
		Panel Size Support	≤32"
		Support Weight (VESA)	≤10kg (≤22lbs)
		Support Weight (Keyboard)	≤3kg(≤6.61lbs)
Height Adjust	Height Adjustment Range (Monitor) / (Arm)	65mm(2.55") / 315mm(12.40")	
	Tension Torque Adjust	Yes	
	Tilt (Profile)	6°	
Extended Arm Provided		1	
Cable Management		Yes	

## Ordering Information

Product No.	KeyBoard Tray Size	Product Description
T9-GA01KB ( Color Remarks)	450mm or 600mm ( Note Remarks)	Workstation,support 32",≤25kg,single Arm with Keyboard tray,75x75 / 100 x 100 mm

All product specifications are subject to change without notice

Last updated: 13-Apr-2025



PRODUCT NO: T8-GA02KB

≤25kg

<b>VESA</b> 100x100 75x75mm 	<b>Tilt</b> 35° 15° 	<b>Rotate</b> 360° 	<b>Swivel</b> 180° 180° 180° 
<b>Cable Management</b> 	<b>Height Adjust</b> 65mm 	<b>Air Pressure Rise and Fall</b> 315mm 	<b>Quick Installation Design</b> 

**Dimensions**

Unit: mm

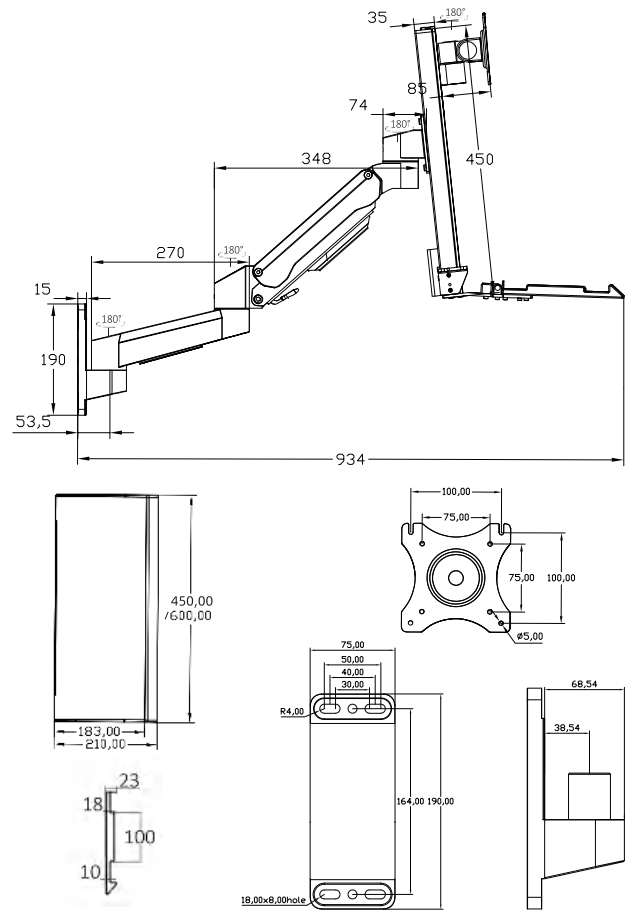

**Specifications**

<b>Complete System</b>	Net Weight	≈8kg (≈17.63lbs)	
	Colour	Black/White/Silver	
	Material	Plastic/Aluminum	
<b>Display System</b>	<b>Hinge Module</b>	Swivel (VESA Hinge)	±90°
		Tilt (VESA Hinge)	-15° ~ + 35°
		Tilt (Keyboard)	0 ~ 90°
		Pivot	180°
		User Torque Adjust	Available
	<b>Display Support</b>	Mounting Pattern	100x100 / 75x75 mm
		Display Type	Singal Monitor
		Panel Size Support	≤32"
		Support Weight (VESA)	≤10kg (≤22lbs)
		Support Weight (Keyboard)	≤3kg(≤6.61lbs)
<b>Height Adjust</b>	Height Adjustment Range	65mm(2.55") / 315mm(12.40")	
	(Monitor) / (Arm)		
	Tension Torque Adjust	Yes	
	Tilt (Profile)	6°	
	Extended Arm Provided	2	
	Cable Management	Yes	

**Ordering Information**

Product No.	KeyBoard Tray Size	Product Description
T9-GA02KB (Color Remarks)	450mm or 600mm (Note Remarks)	Workstation,support 32",≤25kg,single Arm with Keyboard tray,75x75 / 100 x 100 mm

All product specifications are subject to change without notice

Last updated: 13-Apr-2025







PRODUCT NO: T8-MA00KB

≤25kg

VESA	Tilt	Rotate	Swivel
100x100 75x75mm 	35° 15° 	360° 	90° 
Height Adjust	Quick Installation Design		
 65mm			

**Dimensions**

Unit: mm

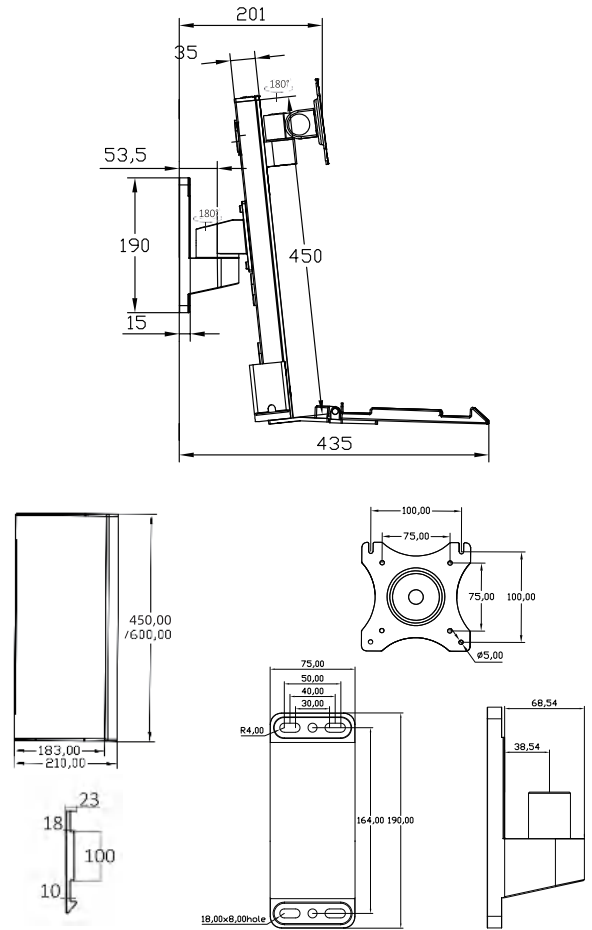

**Specifications**

Complete System	Net Weight	≈5kg (≈11.02lbs)
	Colour	Black/White/Silver
	Material	Plastic/Aluminum
Hinge Module	Swivel (VESA Hinge)	±90°
	Tilt (VESA Hinge)	-15° ~ + 35°
	Tilt (Keyboard)	0 ~ 90°
	Pivot	180°
	User Torque Adjust	Available
	Mounting Pattern	100x100 / 75x75 mm
Display System	Display Support	Panel Size Support ≤32"
	Support Weight (VESA)	≤10kg (≤22lbs)
	Support Weight (Keyboard)	≤3kg(≤6.61lbs)
Height Adjust	Height Adjustment Range (Monitor)	65mm(2.55")
	Tension Torque Adjust	Yes
	Tilt (Profile)	6°
Extended Arm	Provided	0
Cable Management		No

**Ordering Information**







Product No.	KeyBoard Tray Size	Product Description
T8-MA00KB (Color Remarks)	450mm or 600mm (Note Remarks)	Workstation, support 32", ≤25kg, 75x75 / 100 x 100 mm

All product specifications are subject to change without notice

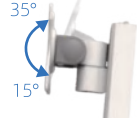
Last updated: 13-Apr-2025



PRODUCT NO: T8-MA01KB  ≤25kg

VESA	Tilt	Rotate	Swivel
100x100 75x75mm 	35° 15° 	360° 	180°/90° 
Cable Management	Height Adjust	Quick Installation Design	
	65mm 		

## Dimensions

Unit: mm

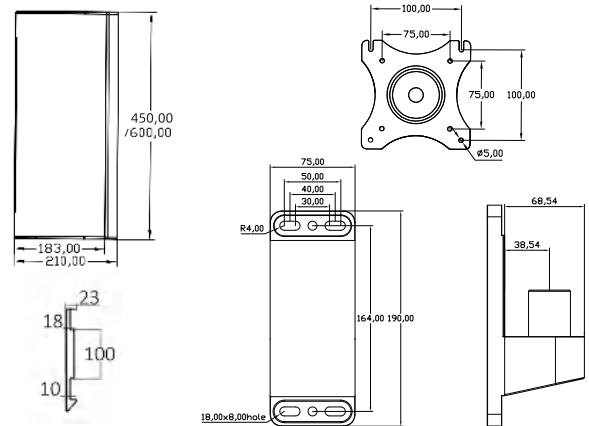
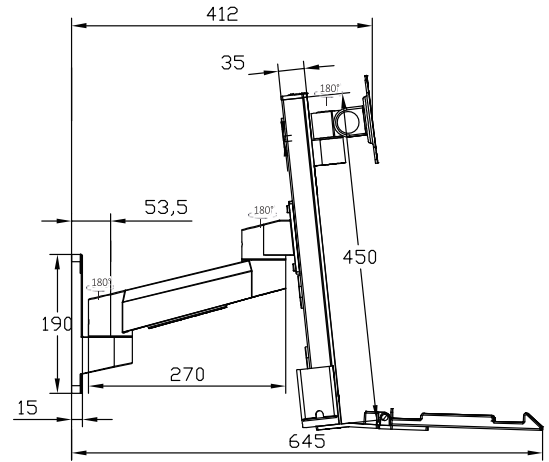

## Specifications

Complete System	Net Weight	≈6kg (≈13.22lbs)	
	Colour	Black/White/Silver	
	Material	Plastic/Aluminum	
Display System	Hinge Module	Swivel (VESA Hinge)	±90°
		Tilt (VESA Hinge)	-15° ~ +35°
		Tilt (Keyboard)	0 ~ 90°
		Pivot	180°
		User Torque Adjust	Available
	Display Support	Mounting Pattern	100x100 / 75x75 mm
		Display Type	Singal Monitor
		Panel Size Support	≤32"
	Height Adjust	Support Weight (VESA)	≤10kg (≤22lbs)
		Support Weight (Keyboard)	≤3kg(≤6.61lbs)
Height Adjustment Range		65mm(2.55")	
(Monitor)			
Extended Arm/Provided	Tension Torque Adjust	Yes	
	Tilt (Profile)	6°	
	Extended Arm/Provided	1	
Cable Management	Yes		

## Ordering Information

Product No.	KeyBoard Tray Size	Product Description
T8-MA01KB (Color Remarks)	450mm or 600mm (Note Remarks)	Workstation,support 32",≤25kg,single Arm with Keyboard tray,75x75 / 100 x 100 mm







All product specifications are subject to change without notice

Last updated: 13-Apr-2025

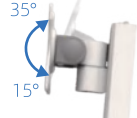



PRODUCT NO: T8-MA02KB  ≤25kg

<b>VESA</b> 100x100 75x75mm 	<b>Tilt</b> 35° 15° 	<b>Rotate</b> 360° 	<b>Swivel</b> 180° 90° 90° 
<b>Cable Management</b> 	<b>Height Adjust</b> 65mm 	<b>Quick Installation Design</b> 	

**Dimensions**

Unit: mm

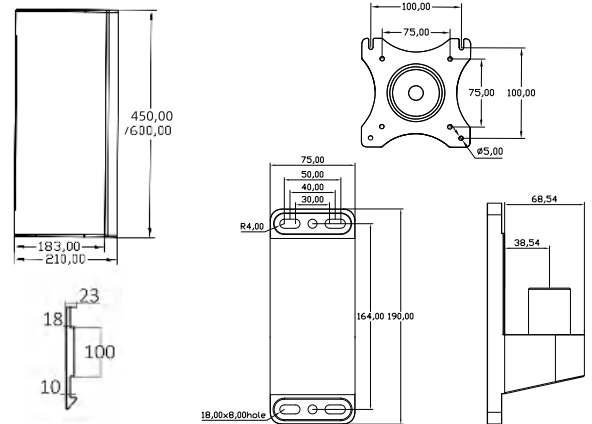
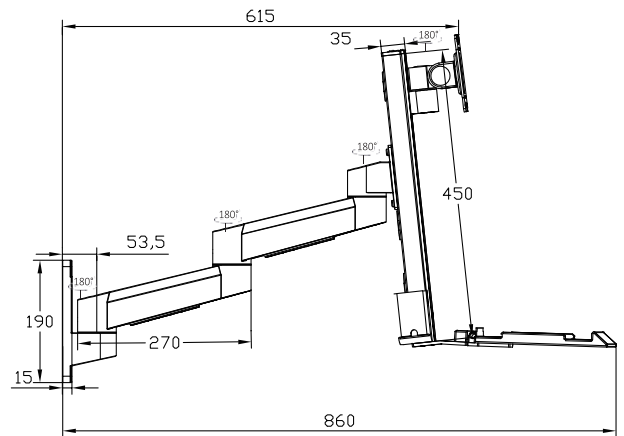

**Specifications**

Complete System	Net Weight	≈7kg (≈15.43lbs)	
	Colour	Black/White/Silver	
	Material	Plastic/Aluminum	
Display System	Hinge Module	Swivel (VESA Hinge)	±90°
		Tilt (VESA Hinge)	-15° ~ +35°
		Tilt (Keyboard)	0 ~ 90°
		Pivot	180°
		User Torque Adjust	Available
	Display Support	Mounting Pattern	100x100 / 75x75 mm
		Display Type	Singal Monitor
		Panel Size Support	≤32"
	Height Adjust	Support Weight (VESA)	≤10kg (≤22lbs)
		Support Weight (Keyboard)	≤3kg(≤6.61lbs)
Height Adjustment Range (Monitor)		65mm(2.55")	
Tension Torque Adjust		Yes	
Extended Arm	Tilt (Profile)	6°	
	Provided	2	
Cable Management	Yes		

**Ordering Information**

Product No.	KeyBoard Tray Size	Product Description
T8-MA02KB (Color Remarks)	450mm or 600mm (Note Remarks)	Workstation, support 32", ≤25kg, Arm with Keyboard tray, 75x75 / 100 x 100 mm







All product specifications are subject to change without notice

Last updated: 13-Apr-2025

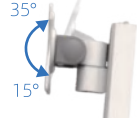

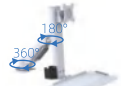

PRODUCT NO: T8-GA01KB-Z  ≤25kg

VESA	Tilt	Rotate	Swivel
100x100 75x75mm 	35° 15° 	360° 	180° 360° 
Cable Management	Height Adjust	Air Pressure Rise and Fall	Quick Installation Design
	65mm 	315mm 	

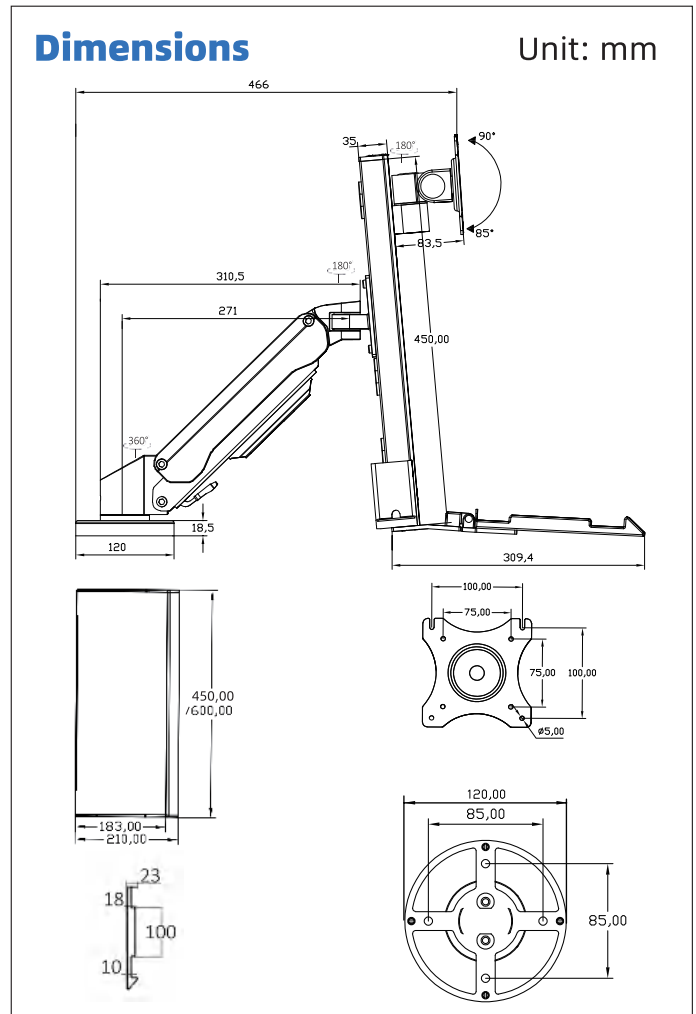

## Specifications

Complete System	Net Weight	≈7kg (≈15.43lbs)	
	Colour	Black/White/Silver	
	Material	Plastic/Aluminum	
Display System	Hinge Module	Swivel (VESA Hinge)	±90°
		Tilt (VESA Hinge)	-15° ~ +35°
		Tilt (Keyboard)	0 ~ 90°
		Pivot	360°
		User Torque Adjust	Available
	Display Support	Mounting Pattern	100x100 / 75x75 mm
		Display Type	Singal Monitor
		Panel Size Support	≤32"
	Height Adjust	Support Weight (VESA)	≤10kg (≤22lbs)
		Support Weight (Keyboard)	≤3kg(≤6.61lbs)
Height Adjustment Range (Monitor) / (Arm)		65mm(2.55") / 315mm(12.40")	
Tension Torque Adjust		Yes	
Extended Arm	Provided	1	
Cable Management		Yes	

## Ordering Information









Product No.	KeyBoard Tray Size	Product Description
T8-GA01KB-Z (Color Remarks)	450mm or 600mm (Note Remarks)	Workstation,support 32",≤25kg,single Arm with Keyboard tray,75x75 / 100 x 100 mm

All product specifications are subject to change without notice

Last updated: 13-Apr-2025



PRODUCT NO: T8-GA02KB-Z  ≤25kg

<b>VESA</b> 100x100 75x75mm 	<b>Tilt</b> 35° 15° 	<b>Rotate</b> 360° 	<b>Swivel</b> 180° 360° 180° 
<b>Cable Management</b> 	<b>Height Adjust</b> 65mm 	<b>Air Pressure Rise and Fall</b> 315mm 	<b>Quick Installation Design</b> 

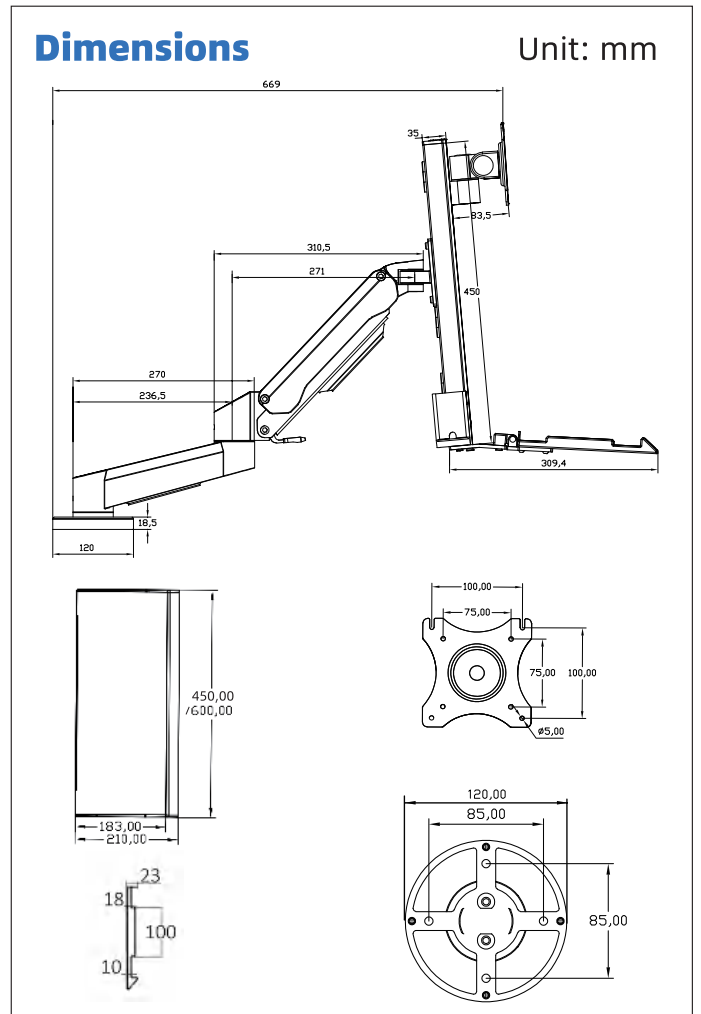

**Specifications**

<b>Complete System</b>	Net Weight	≈8kg (≈17.63lbs)	
	Colour	Black/White/Silver	
	Material	Plastic/Aluminum	
<b>Display System</b>	<b>Hinge Module</b>	Swivel (VESA Hinge)	±90°
		Tilt (VESA Hinge)	-15° ~ + 35°
		Tilt (Keyboard)	0 ~ 90°
		Pivot	360°
		User Torque Adjust	Available
	<b>Display Support</b>	Mounting Pattern	100x100 / 75x75 mm
		Display Type	Singal Monitor
		Panel Size Support	≤32"
		Support Weight (VESA)	≤10kg (≤22lbs)
		Support Weight (Keyboard)	≤3kg(≤6.61lbs)
<b>Height Adjust</b>	Height Adjustment Range (Monitor) / (Arm)	65mm(2.55") / 315mm(12.40")	
	Tension Torque Adjust	Yes	
	Tilt (Profile)	6°	
<b>Extended Arm</b> Provided		2	
<b>Cable Management</b>		Yes	

**Ordering Information**





Product No.	KeyBoard Tray Size	Product Description
T8-GA02KB-Z (Color Remarks)	450mm or 600mm (Note Remarks)	Workstation, support 32", ≤25kg, Arm with Keyboard tray, 75x75 / 100 x 100 mm





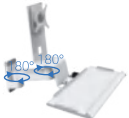

PRODUCT NO: T9-MA01KBL  ≤25kg

VESA	Tilt	Rotate	Swivel
100x100 75x75mm 	15° 	360° 	30°/180° 
<b>Cable Management</b> 	<b>Quick Installation Design</b> 		

## Dimensions

Unit: mm

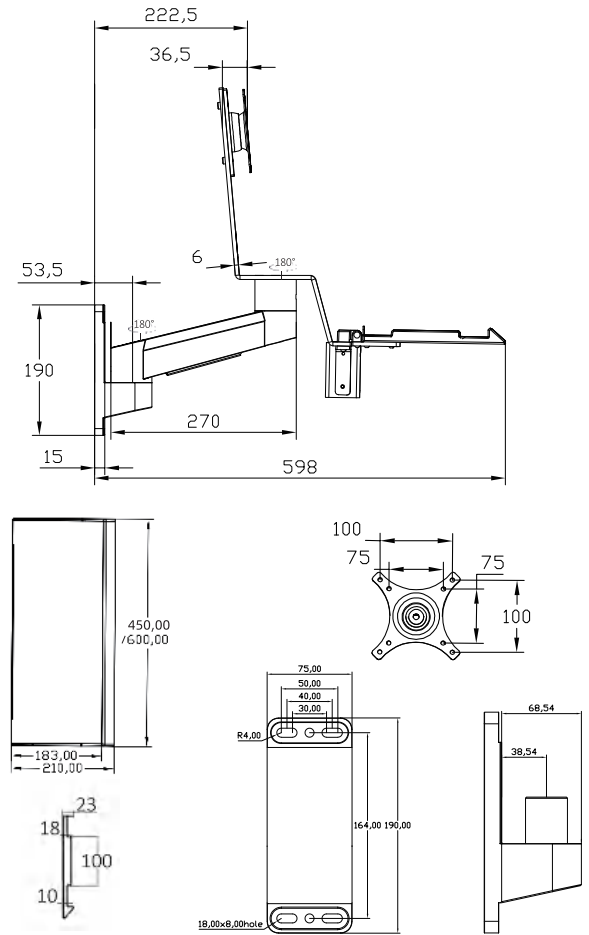

## Specifications

Complete System	Net Weight	≈5.5kg (≈12.13lbs)	
	Colour	Black/White/Silver	
	Material	Plastic/Aluminum	
Display System	Hinge Module	Swivel (VESA Hinge)	±15°
		Tilt (VESA Hinge)	-15° ~ +15°
		Tilt (Keyboard)	0 ~ 90°
		Pivot	180°
		User Torque Adjust	Available
	Display Support	Mounting Pattern	100x100 / 75x75 mm
		Display Type	Singal Monitor
		Panel Size Support	≤32"
		Support Weight (VESA)	≤10kg (≤22lbs)
		Support Weight (Keyboard)	≤3kg(≤6.61lbs)
Height Adjust	Height Adjustment Range	No	
	Tension Torque Adjust	Yes	
	Tilt (Profile)	6°	
Extended Arm	Provided	1	
Cable Management		Yes	

## Ordering Information

Product No.	KeyBoard Tray Size	Product Description
T9-MA01KBL (Color Remarks)	450mm or 600mm (Note Remarks)	Workstation,support 32",≤25kg,single Arm with Keyboard tray,75x75 / 100 x 100 mm

All product specifications are subject to change without notice

Last updated: 13-Apr-2025



PRODUCT NO: T9-MA02KBL

≤25kg

VESA	Tilt	Rotate	Swivel
100x100 75x75mm 	15° 	360° 	180°/360° 
Cable Management 	Quick Installation Design 		

## Dimensions

Unit: mm

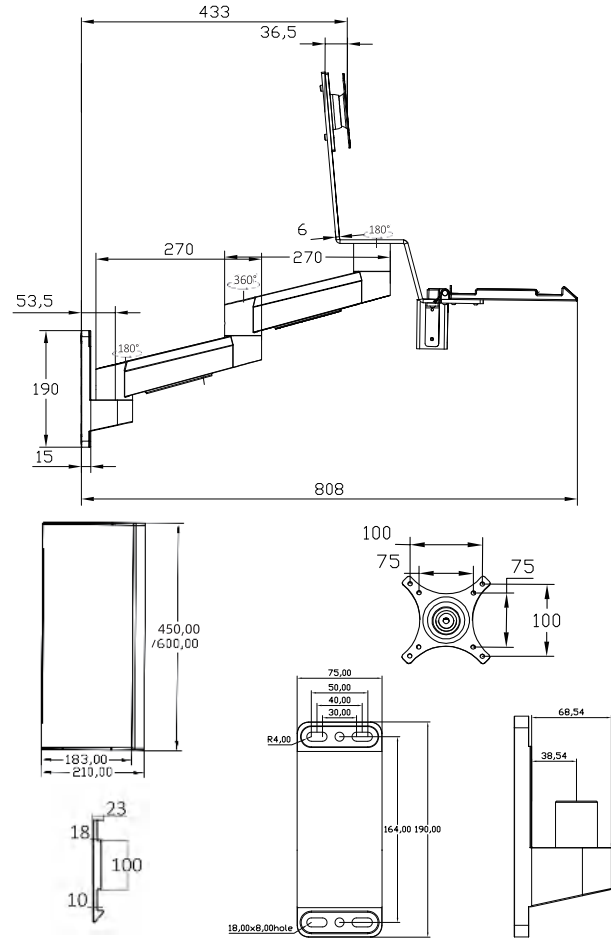

## Specifications

Complete System	Net Weight	≈6.5kg (≈14.33lbs)	
	Colour	Black/White/Silver	
	Material	Plastic/Aluminum	
Display System	Hinge Module	Swivel (VESA Hinge)	±15°
		Tilt (VESA Hinge)	-15° ~ + 15°
		Tilt (Keyboard)	0 ~ 90°
		Pivot	360°
		User Torque Adjust	Available
	Display Support	Mounting Pattern	100x100 / 75x75 mm
		Display Type	Singal Monitor
		Panel Size Support	≤32"
		Support Weight (VESA)	≤10kg (≤22lbs)
		Support Weight (Keyboard)	≤3kg(≤6.61lbs)
Height Adjust	Height Adjustment Range (Monitor ) / (Arm)	No	
	Tension Torque Adjust	Yes	
	Tilt (Profile)	6°	
Extended Arm	Provided	2	
Cable Management		Yes	

## Ordering Information







Product No.	KeyBoard Tray Size	Product Description
T9-MA02KBL (Color Remarks)	450mm or 600mm (Note Remarks)	Workstation,support 32",≤25kg,Arm with Keyboard tray,75x75 / 100 x 100 mm

All product specifications are subject to change without notice

Last updated: 13-Apr-2025



PRODUCT NO: T9-GA01KBL  ≤25kg

VESA	Tilt	Rotate	Swivel
100x100 75x75mm 	15° 	360° 	180° 
Cable Management 	Air Pressure Rise and Fall 315mm 	Quick Installation Design 	

## Dimensions

Unit: mm

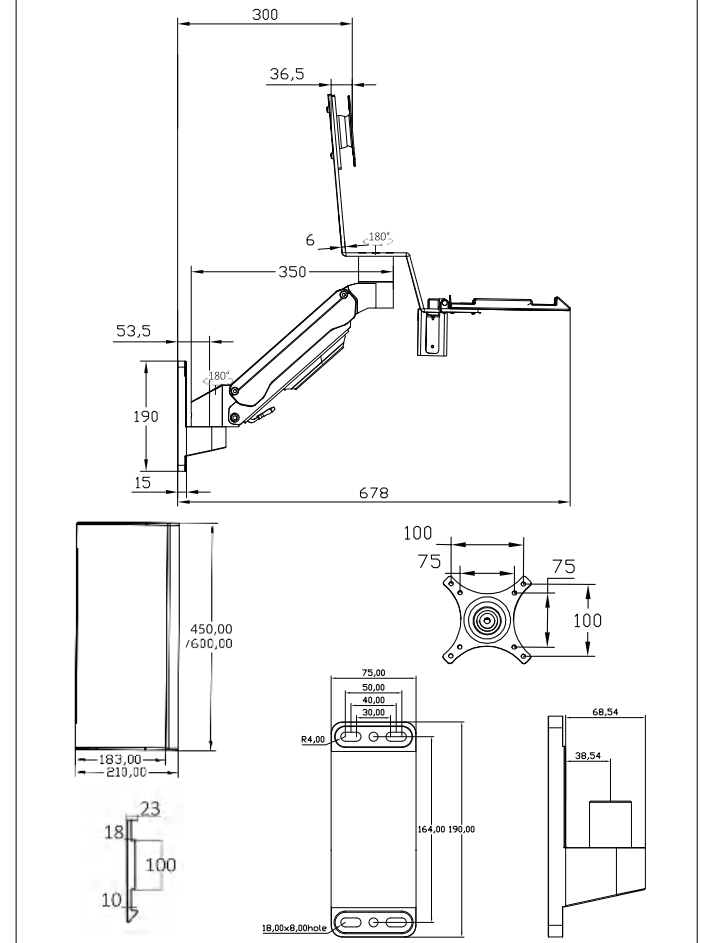

## Specifications

Complete System	Net Weight	≈6kg (≈13.22lbs)	
	Colour	Black/White/Silver	
	Material	Plastic/Aluminum	
Display System	Hinge Module	Swivel (VESA Hinge)	±15°
		Tilt (VESA Hinge)	-15° ~ + 15°
		Tilt (Keyboard)	0 ~ 90°
		Pivot	180°
		User Torque Adjust	Available
	Display Support	Mounting Pattern	100x100 / 75x75 mm
		Display Type	Singal Monitor
Height Adjust	Panel Size Support	≤32"	
	Support Weight (VESA)	≤10kg (≤22lbs)	
	Support Weight (Keyboard)	≤3kg(≤6.61lbs)	
	Height Adjustment Range (Arm)	315mm(12.40")	
Extended Arm/Provided	Tension Torque Adjust	Yes	
	Tilt (Profile)	6°	
	Cable Management	Yes	

## Ordering Information

Product No.	KeyBoard Tray Size	Product Description
T9-GA01KBL (Color Remarks)	450mm or 600mm (Note Remarks)	Workstation,support 32",≤25kg,single Arm with Keyboard tray,75x75 / 100 x 100 mm







All product specifications are subject to change without notice

Last updated: 13-Apr-2025





PRODUCT NO: T9-GA02KBL  ≤25kg

VESA	Tilt	Rotate	Swivel
100x100 75x75mm	15° 15°	360°	180° 180° 180°
			
Cable Management	Air Pressure Rise and Fall	Quick Installation Design	
			

**Dimensions**

Unit: mm

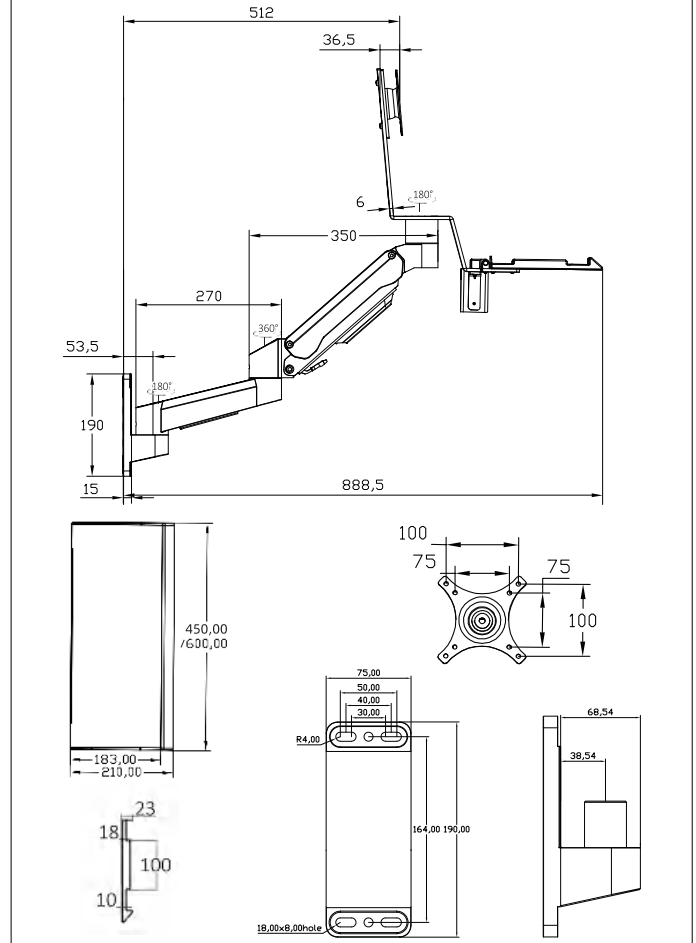

**Specifications**

Complete System	Net Weight	≈7kg (≈15.43lbs)	
	Colour	Black/White/Silver	
	Material	Plastic/Aluminum	
Display System	Hinge Module	Swivel (VESA Hinge)	±15°
		Tilt (VESA Hinge)	-15° ~ +15°
		Tilt (Keyboard)	0 ~ 90°
		Pivot	360°
		User Torque Adjust	Available
	Display Support	Mounting Pattern	100x100 / 75x75 mm
		Display Type	Singal Monitor
		Panel Size Support	≤32"
		Support Weight (VESA)	≤10kg (≤22lbs)
		Support Weight (Keyboard)	≤3kg(≤6.61lbs)
Height Adjust	Height Adjustment Range (Arm)	315mm(12.40")	
	Tension Torque Adjust	Yes	
	Tilt (Profile)	6°	
Extended Arm	Provided	2	
Cable Management		Yes	

**Ordering Information**

Product No.	KeyBoard Tray Size	Product Description
T9-GA02KBL (Color Remarks)	450mm or 600mm (Note Remarks)	Workstation,support 32",≤25kg, Arm with Keyboard tray,75x75 / 100 x 100 mm

All product specifications are subject to change without notice

Last updated: 13-Apr-2025



PRODUCT NO: T8-WA00-W

≤15kg

VESA	Tilt	Rotate	Swivel
100x100 75x75mm 	35° 15°	360°	180°
<b>Quick Installation Design</b>			

## Dimensions

Unit: mm

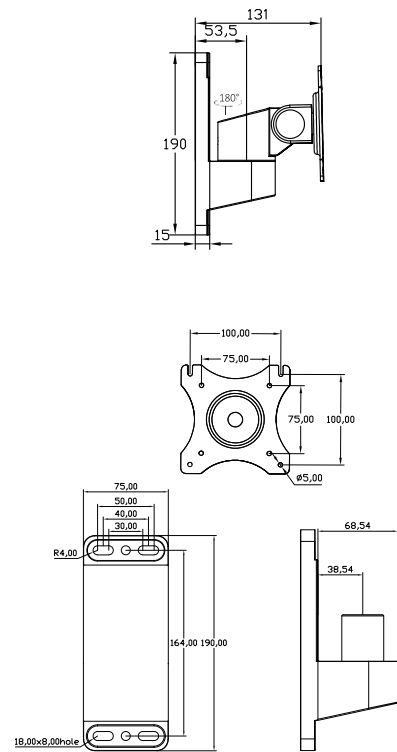

## Specifications

Complete System	Net Weight	≈1.5kg (≈3.3lbs)	
	Colour	Black/White/Silver	
	Material	Plastic/Aluminum	
Display System	Hinge Module	Swivel (VESA Hinge)	±90°
		Tilt (VESA Hinge)	-15° ~ + 35°
		Pivot	180°
	Display Support	User Torque Adjust	No
		Mounting Pattern	100x100 / 75x75 mm
		Display Type	Singal Monitor
		Panel Size Support	≤32"
		Support Weight (VESA)	≤15kg (≤33lbs)
		Extended ArmProvided	0
Cable Management	No		

## Ordering Information

Product No.	Product Description
T8-WA00-W ( Color Remarks )	WallArm, patented VESA,,support 32",≤15kg,75x75 / 100 x 100 mm

All product specifications are subject to change without notice

Last updated: 13-Apr-2025











PRODUCT NO: T8-WA01-W

≤15kg

VESA	Tilt	Rotate	Swivel
100x100 75x75mm 	35° 15° 	360° 	180° 
Air Pressure Rise and Fall 	Quick Installation Design 		

**Dimensions**

Unit: mm

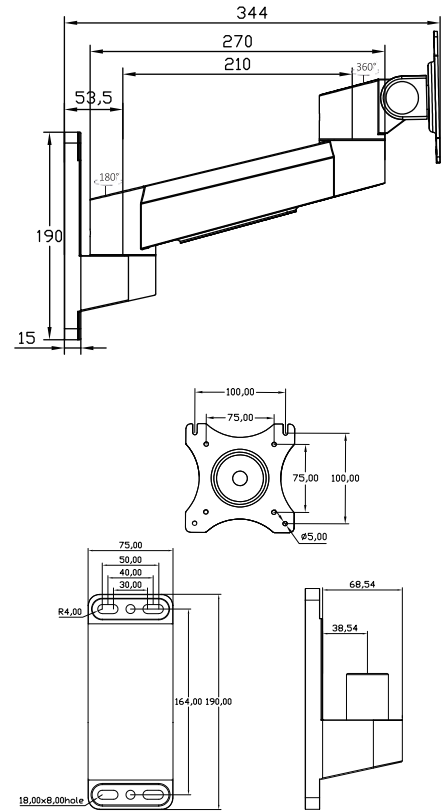

**Specifications**

Complete System	Net Weight	≈2.5kg (≈5.51lbs)	
	Colour	Black/White/Silver	
	Material	Plastic/Aluminum	
Display System	Hinge Module	Swivel (VESA Hinge)	±90°
		Tilt (VESA Hinge)	-15° ~ + 35°
		Pivot	360°
		User Torque Adjust	No
	Display Support	Mounting Pattern	100x100 / 75x75 mm
		Display Type	Singal Monitor
		Panel Size Support	≤32"
	Support Weight (VESA)	≤15kg (≤33lbs)	
	Extended Arm Provided	1	
	Cable Management	Yes	

**Ordering Information**

Product No.	Product Description
T8-WA01-W ( Color Remarks )	WallArm, patented VESA,,support 32",≤15kg,single Arm ,75x75 / 100 x 100 mm

All product specifications are subject to change without notice

Last updated: 13-Apr-2025



PRODUCT NO: T8-WA02-W

≤15kg

VESA	Tilt	Rotate	Swivel
100x100 75x75mm 	35° 15° 	360° 	360° 180° 
Air Pressure Rise and Fall 	Quick Installation Design 		

## Dimensions

Unit: mm

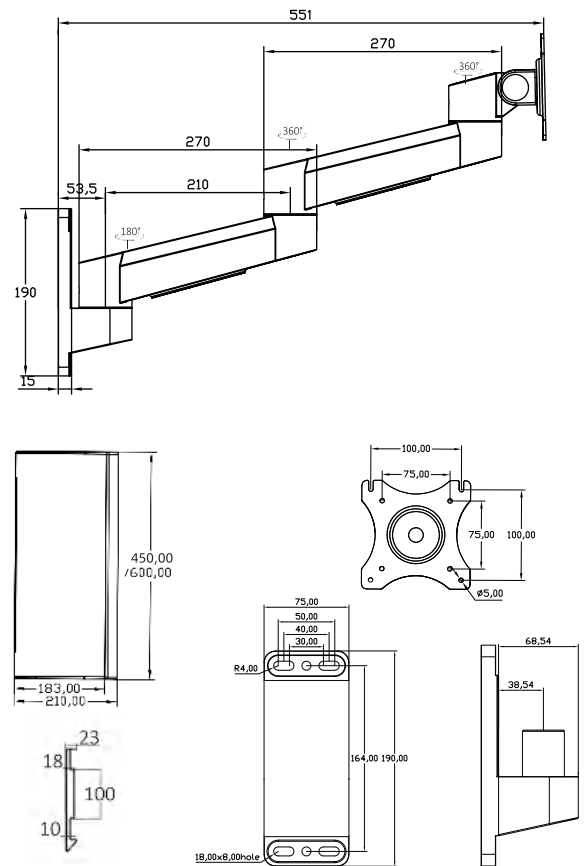

## Specifications

Complete System	Net Weight	≈3.5kg (≈7.71bs)	
	Colour	Black/White/Silver	
	Material	Plastic/Aluminum	
Display System	Hinge Module	Swivel (VESA Hinge)	±90°
		Tilt (VESA Hinge)	-15° ~ + 35°
		Pivot	360°
		User Torque Adjust	No
	Display Support	Mounting Pattern	100x100 / 75x75 mm
		Display Type	Singal Monitor
		Panel Size Support	≤32"
	Support Weight (VESA)	≤15kg (≤33lbs)	
	Extended Arm Provided	2	
	Cable Management	Yes	

## Ordering Information

Product No.	Product Description
T8-WA02-W ( Color Remarks)	WallArm, patented VESA,,support 32",≤15kg,75x75 / 100 x 100 mm

All product specifications are subject to change without notice

Last updated: 13-Apr-2025



PRODUCT NO: T8-GA01-W

≤15kg

VESA 100x100 75x75mm 	Tilt 	Rotate 	Swivel 
Cable Management 	Air Pressure Rise and Fall 	Quick Installation Design 	

**Dimensions**

Unit: mm

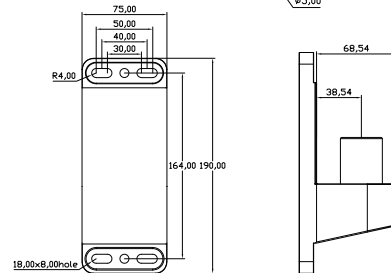
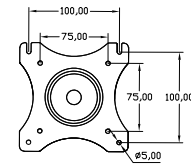
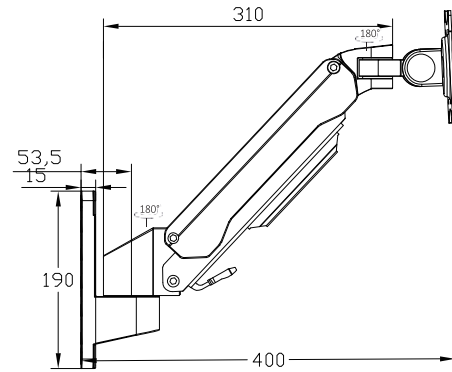

**Specifications**

Complete System	Net Weight	≈3.5kg (≈7.71lbs)
	Colour	Black/White/Silver
	Material	Plastic/Aluminum
Hinge Module	Swivel (VESA Hinge)	±90°
	Tilt (VESA Hinge)	-15° ~ + 35°
	Pivot	180°
	User Torque Adjust	Available
	Mounting Pattern	100x100 / 75x75 mm
Display System	Display Type	Singal Monitor
	Display Support	Panel Size Support ≤32" Support Weight (VESA) ≤15kg (≤33lbs) Height Adjustment Range 315mm(12.40")
Height Adjust	(Arm)	
	Tension Torque Adjust	Yes
Extended Arm	Provided	1
Cable Management		Yes

**Ordering Information**

Product No.	Product Description
T8-GA01-W (Color Remarks)	WallArm, patented VESA,,support 32",≤15kg,75x75 / 100 x 100 mm

All product specifications are subject to change without notice

Last updated: 13-Apr-2025



PRODUCT NO: T8-GA02-W

≤15kg

VESA	Tilt	Rotate	Swivel
100x100 75x75mm 			
Cable Management 	Air Pressure Rise and Fall 	Quick Installation Design 	

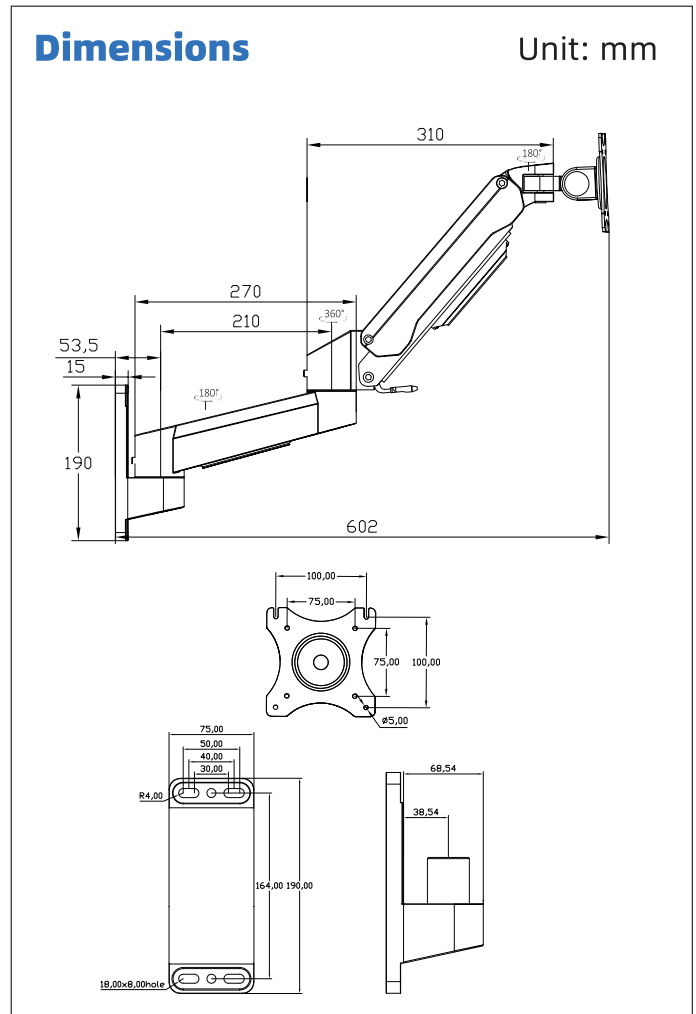

## Specifications

Complete System	Net Weight	≈4.5kg (≈9.92lbs)	
	Colour	Black/White/Silver	
	Material	Plastic/Aluminum	
Display System	Hinge Module	Swivel (VESA Hinge)	±90°
		Tilt (VESA Hinge)	-15° ~ + 35°
		Pivot	360°
		User Torque Adjust	Available
	Display Support	Mounting Pattern	100x100 / 75x75 mm
Display Type		Singal Monitor	
Panel Size Support		≤32"	
Height Adjust	Support Weight (VESA)	≤15kg (≤33lbs)	
	Height Adjustment Range (Arm)	315mm(12.40")	
	Tension Torque Adjust	Yes	
	Extended Arm Provided	2	
Cable Management	Yes		

## Ordering Information

Product No.	Product Description
T8-GA02-W (Color Remarks)	WallArm, patented VESA,,support 32",≤15kg,75x75 / 100 x 100 mm

All product specifications are subject to change without notice

Last updated: 13-Apr-2025





PRODUCT NO: T9-GA01-W

≤15kg

VESA	Tilt	Rotate	Swivel
100x100 75x75mm 	35° 15° 	360° 	36° 180° 
Cable Management 	Air Pressure Rise and Fall 315mm 	Quick Installation Design 	

**Dimensions**

Unit: mm

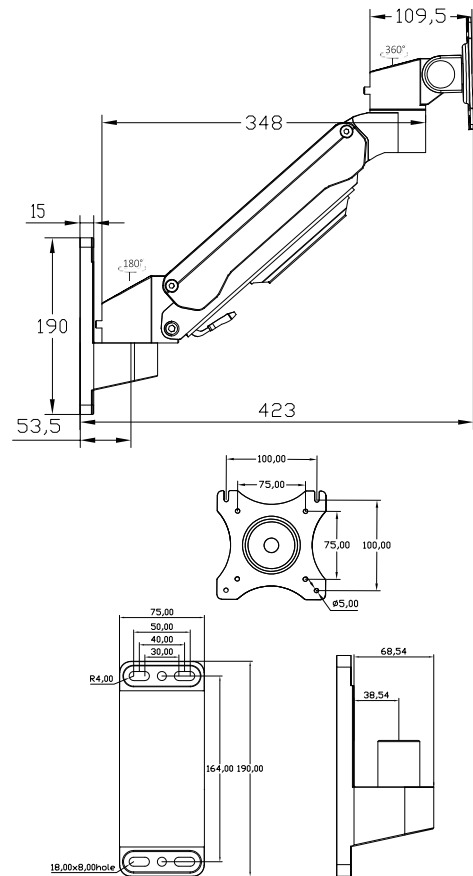

**Specifications**

Complete System	Net Weight	≈4kg (≈8.82lbs)		
	Colour	Black/White/Silver		
	Material	Plastic/Aluminum		
Display System	Hinge Module	Swivel (VESA Hinge)	±90°	
		Tilt (VESA Hinge)	-15° ~ + 35°	
		Pivot	360°	
		User Torque Adjust	Available	
	Display Support	Mounting Pattern	100x100 / 75x75 mm	
		Display Type	Singal Monitor	
		Panel Size Support	≤32"	
		Support Weight (VESA)	≤15kg (≤33lbs)	
	Height Adjust	Height Adjustment Range (Arm)	315mm(12.40")	
		Tension Torque Adjust	Yes	
Extended Arm Provided	1			
Cable Management	Yes			

**Ordering Information**

Product No.	Product Description
T9-GA01-W (Color Remarks)	WallArm, patented VESA, support 32", ≤25kg, Arm with Keyboard tray, 75x75 / 100 x 100 mm

All product specifications are subject to change without notice

Last updated: 13-Apr-2025



PRODUCT NO: T9-GA02-W

≤15kg

VESA	Tilt	Rotate	Swivel
100x100 75x75mm 	35° 15° 	360° 	360° 180° 
Cable Management 	Air Pressure Rise and Fall 315mm 	Quick Installation Design 	

## Dimensions

Unit: mm

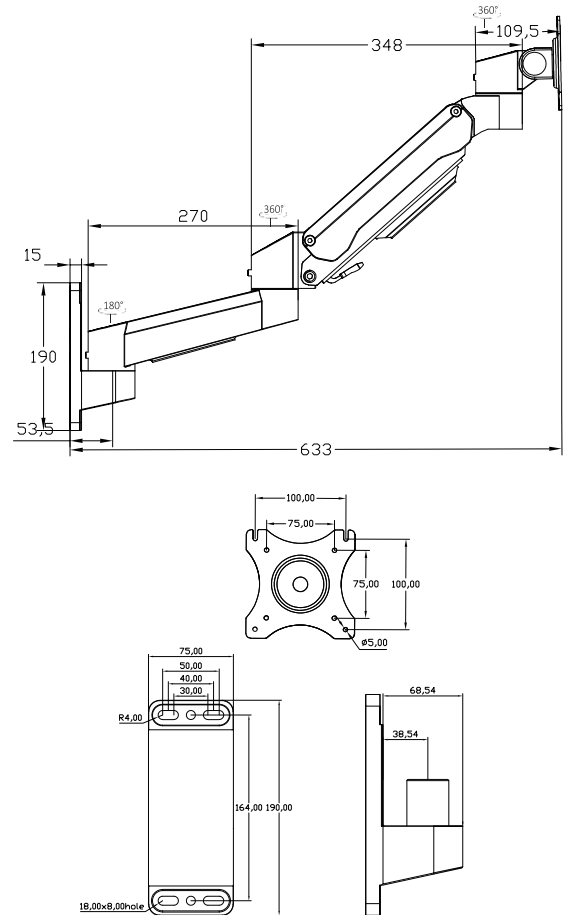

## Specifications

Complete System	Net Weight	≈5kg (≈11.02lbs)		
	Colour	Black/White/Silver		
	Material	Plastic/Aluminum		
Display System	Hinge Module	Swivel (VESA Hinge)	±90°	
		Tilt (VESA Hinge)	-15° ~ + 35°	
		Pivot	360°	
		User Torque Adjust	Available	
	Display Support	Mounting Pattern	100x100 / 75x75 mm	
		Display Type	Singal Monitor	
		Panel Size Support	≤32"	
		Support Weight (VESA)	≤15kg (≤33lbs)	
	Height Adjust	Height Adjustment Range (Arm)	315mm(12.40")	
		Tension Torque Adjust	Yes	
Extended Arm	Provided	2		
Cable Management		Yes		

## Ordering Information

Product No.	Product Description
T9-GA02-W (Color Remarks)	WallArm, patented VESA,support 32",≤25kg, Arm with Keyboard tray,75x75 / 100 x 100 mm

All product specifications are subject to change without notice

Last updated: 13-Apr-2025





PRODUCT NO: T8-GA01-Z

≤15kg

VESA	Tilt	Rotate	Swivel
100x100 75x75mm 			
Cable Management 	Air Pressure Rise and Fall 	Quick Installation Design 	

## Dimensions

Unit: mm

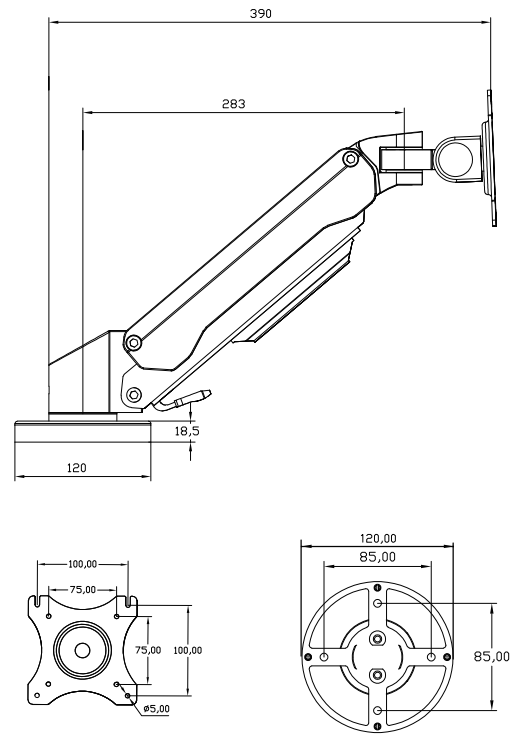

## Specifications

Complete System	Net Weight	≈4kg (≈8.82lbs)		
	Colour	Black/White/Silver		
	Material	Plastic/Aluminum		
Display System	Hinge Module	Swivel (VESA Hinge)	±90°	
		Tilt (VESA Hinge)	-15° ~ + 35°	
		Pivot	360°	
		User Torque Adjust	Available	
	Display Support	Mounting Pattern	100x100 / 75x75 mm	
		Display Type	Singal Monitor	
		Panel Size Support	≤32"	
		Support Weight (VESA)	≤15kg (≤33lbs)	
	Height Adjust	Height Adjustment Range (Arm)	315mm(12.40")	
		Tension Torque Adjust	Yes	
Extended Arm	Provided	1		
Cable Management		Yes		

## Ordering Information

Product No.	Product Description
T8-GA01-Z (Color Remarks)	WallArm, patented VESA,support 32",≤25kg, Arm with Keyboard tray,75x75 / 100 x 100 mm

All product specifications are subject to change without notice

Last updated: 13-Apr-2025





PRODUCT NO: T8-GA02-Z

≤15kg

VESA	Tilt	Rotate	Swivel
100x100 75x75mm 			
Cable Management	Air Pressure Rise and Fall	Quick Installation Design	

## Dimensions

Unit: mm

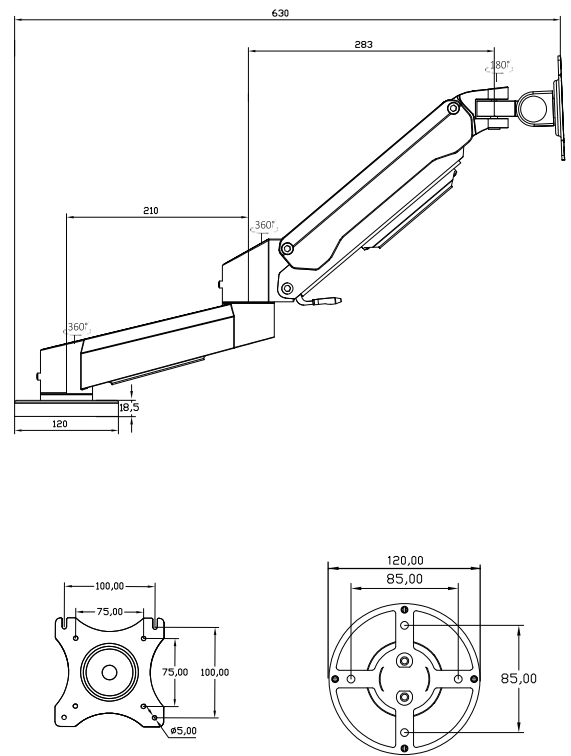

## Specifications

Complete System	Net Weight	≈5kg (≈11.02lbs)		
	Colour	Black/White/Silver		
	Material	Plastic/Aluminum		
Display System	Hinge Module	Swivel (VESA Hinge)	±90°	
		Tilt (VESA Hinge)	-15° ~ + 35°	
		Pivot	360°	
		User Torque Adjust	Available	
	Display Support	Mounting Pattern	100x100 / 75x75 mm	
		Display Type	Singal Monitor	
		Panel Size Support	≤32"	
		Support Weight (VESA)	≤15kg (≤33lbs)	
	Height Adjust	Height Adjustment Range (Arm)	315mm(12.40")	
		Tension Torque Adjust	Yes	
Extended Arm	Provided	2		
Cable Management		Yes		

## Ordering Information

Product No.	Product Description
T8-GA02-Z (Color Remarks)	WallArm, patented VESA, support 32", ≤25kg, Arm with Keyboard tray, 75x75 / 100 x 100 mm

All product specifications are subject to change without notice

Last updated: 13-Apr-2025









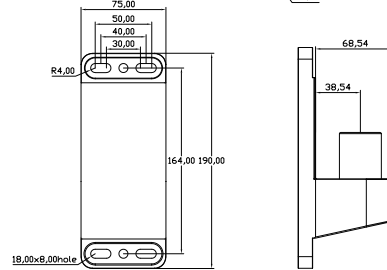
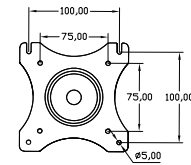
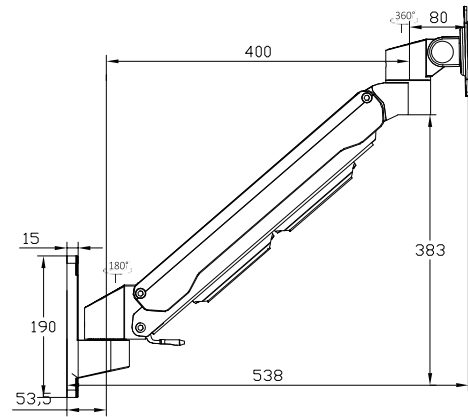

## Dimensions

Unit: mm



PRODUCT NO: T9-GA01-W PLUS  ≤15kg

VESA	Tilt	Rotate	Swivel
100x100 75x75mm 			
Cable Management 	Air Pressure Rise and Fall 	Quick Installation Design 	

## Specifications

Complete System	Net Weight	≈4.5kg (≈9.92lbs)	
	Colour	Black/White/Silver	
	Material	Plastic/Aluminum	
Display System	Hinge Module	Swivel (VESA Hinge)	±90°
		Tilt (VESA Hinge)	-15° ~ + 35°
		Pivot	360°
		User Torque Adjust	Available
	Display Support	Mounting Pattern	100x100 / 75x75 mm
Display Type		Singal Monitor	
Height Adjust	Panel Size Support	≤32"	
	Support Weight (VESA)	≤15kg (≤33lbs)	
	Height Adjustment Range (Arm)	535mm(21.06")	
	Tension Torque Adjust	Yes	
	Extended Arm Provided	1	
	Cable Management	Yes	

## Ordering Information







Product No.	Product Description
T9-GA01-W PLUS (Color Remarks)	WallArm, patented VESA,,support 32",≤15kg,75x75 / 100 x 100 mm

All product specifications are subject to change without notice

Last updated: 13-Apr-2025



PRODUCT NO: T9-GA01-W PLUS  ≤15kg

VESA	Tilt	Rotate	Swivel
100x100 75x75mm 			
Cable Management 	Air Pressure Rise and Fall 	Quick Installation Design 	

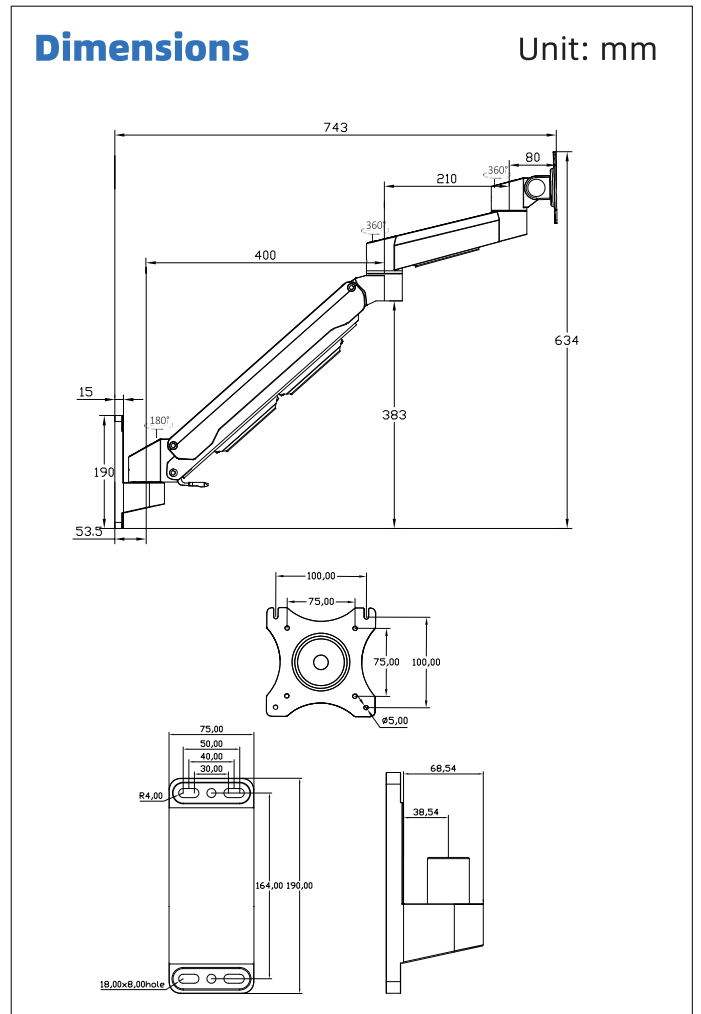

## Specifications

Complete System	Net Weight	≈5.5kg (≈12.13lbs)	
	Colour	Black/White/Silver	
	Material	Plastic/Aluminum	
Display System	Hinge Module	Swivel (VESA Hinge)	±90°
		Tilt (VESA Hinge)	-15° ~ + 35°
		Pivot	360°
		User Torque Adjust	Available
	Display Support	Mounting Pattern	100x100 / 75x75 mm
Display Type		Singal Monitor	
Panel Size Support		≤32"	
Height Adjust	Support Weight (VESA)	≤15kg (≤33lbs)	
	Height Adjustment Range (Arm)	535mm(21.06")	
	Tension Torque Adjust	Yes	
Extended Arm Provided		2	
Cable Management		Yes	

## Ordering Information

Product No.	Product Description
T9-GA01-W PLUS (Color Remarks)	WallArm, patented VESA,,support 32",≤15kg,75x75 / 100 x 100 mm

All product specifications are subject to change without notice

Last updated: 13-Apr-2025





105

H06









## Dimensions

Unit: mm

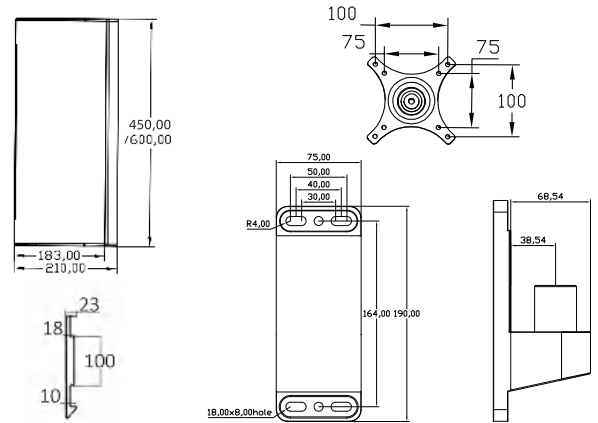
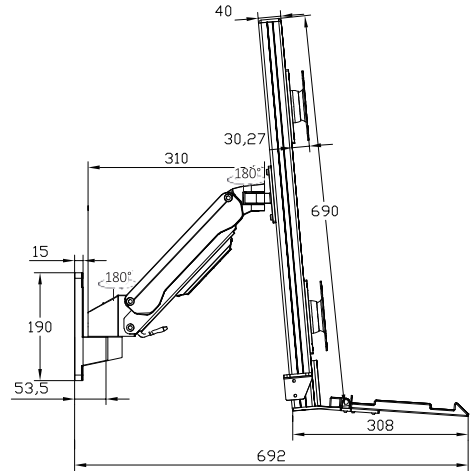

PRODUCT NO: T8-GA01KB-SPA  ≤20kg

VESA	Tilt	Rotate	Swivel
100x100 75x75mm 	15° 15° 	360° 	180° 180° 
Cable Management	Air Pressure Rise and Fall	Height Adjust	
	315mm 	480mm 	

## Specifications

Complete System	Net Weight	≈8kg (≈17.64lbs)		
	Colour	White/Silver		
	Material	Plastic/Aluminum		
Display System	Hinge Module	Swivel (VESA Hinge)	±15°	
		Tilt (VESA Hinge)	-15° ~ +15°	
		Tilt (Keyboard)	0 ~ 90°	
		Pivot	180°	
		User Torque Adjust	Available	
	Display Support	Mounting Pattern	100x100 / 75x75 mm	
		Display Type	Singal Monitor	
		Panel Size Support	≤32"	
		Single Support Weight (VESA)	≤7kg (≤15.4lbs)	
		Support Weight (Keyboard)	≤3kg(≤6.61lbs)	
		Height Adjust	Height Adjustment Range (Monitor) / (Arm)	480mm(18.89") / 315mm(12.40")
			Tension Torque Adjust	Yes
			Tilt (Profile)	6°
Extended Arm Provided		1		
Cable Management		Yes		

## Ordering Information

Product No.	KeyBoard Tray Size	Product Description
T8-GA01KB-SPA (Color Remarks)	450mm or 600mm (Note Remarks)	Workstation, support 32", ≤20kg, Arm with Keyboard tray, 75x75 / 100 x 100 mm

All product specifications are subject to change without notice

Last updated: 13-Apr-2025







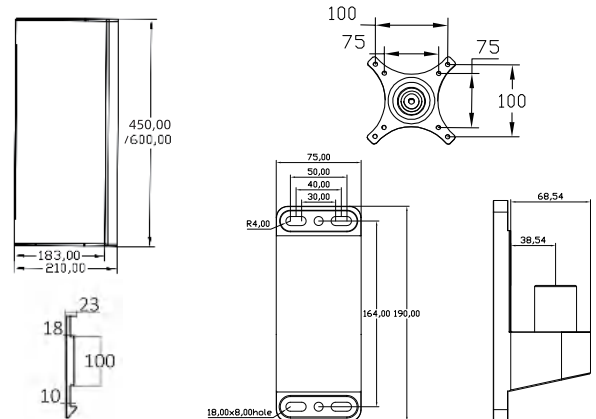
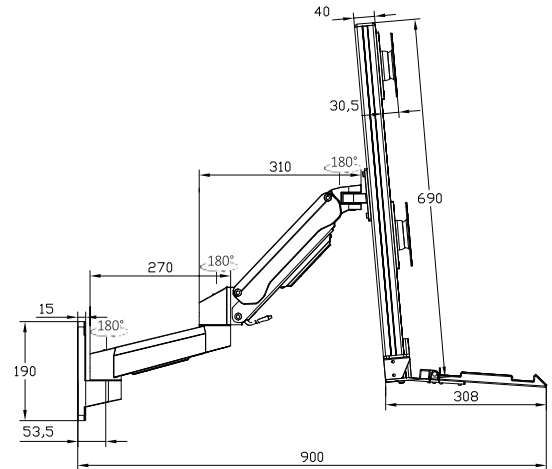

## Dimensions

Unit: mm



PRODUCT NO: T8-GA02KB-SPA  ≤20kg

VESA	Tilt	Rotate	Swivel
100x100 75x75mm 	15° 15° 	360° 	180° 180° 
Cable Management	Air Pressure Rise and Fall	Height Adjust	
	315mm 	480mm 	

## Specifications

Complete System	Net Weight	≈9kg (≈19.84lbs)	
	Colour	White/Silver	
	Material	Plastic/Aluminum	
Display System	Hinge Module	Swivel (VESA Hinge)	±15°
		Tilt (VESA Hinge)	-15° ~ + 15°
		Tilt (Keyboard)	0 ~ 90°
		Pivot	180°
		User Torque Adjust	Available
	Display Support	Mounting Pattern	100x100 / 75x75 mm
		Display Type	Singal Monitor
		Panel Size Support	≤32"
		Single Support Weight (VESA)	≤7kg (≤15.4lbs)
		Support Weight (Keyboard)	≤3kg(≤6.61lbs)
		Height Adjustment Range	480mm(18.89") / 315mm(12.40")
		Height Adjust	(Monitor) / (Arm)
	Extended Arm	Tension Torque Adjust	Yes
		Tilt (Profile)	6°
		Extended Arm Provided	2
Cable Management		Yes	

## Ordering Information

Product No.	KeyBoard Tray Size	Product Description
T8-GA02KB-SPA (Color Remarks)	450mm or 600mm (Note Remarks)	Workstation, support 32", ≤20kg, Arm with Keyboard tray, 75x75 / 100 x 100 mm









All product specifications are subject to change without notice

Last updated: 13-Apr-2025





PRODUCT NO: T8-GA01KB-SPB  ≤20kg

<b>VESA</b> 100x100 75x75mm 	<b>Tilt</b> 35° 15° 	<b>Rotate</b> 360° 	<b>Swivel</b> 180° 160° 
<b>Cable Management</b> 	<b>Air Pressure Rise and Fall</b> 315mm 	<b>Height Adjust</b> 385mm 	<b>Quick Installation Design</b> 

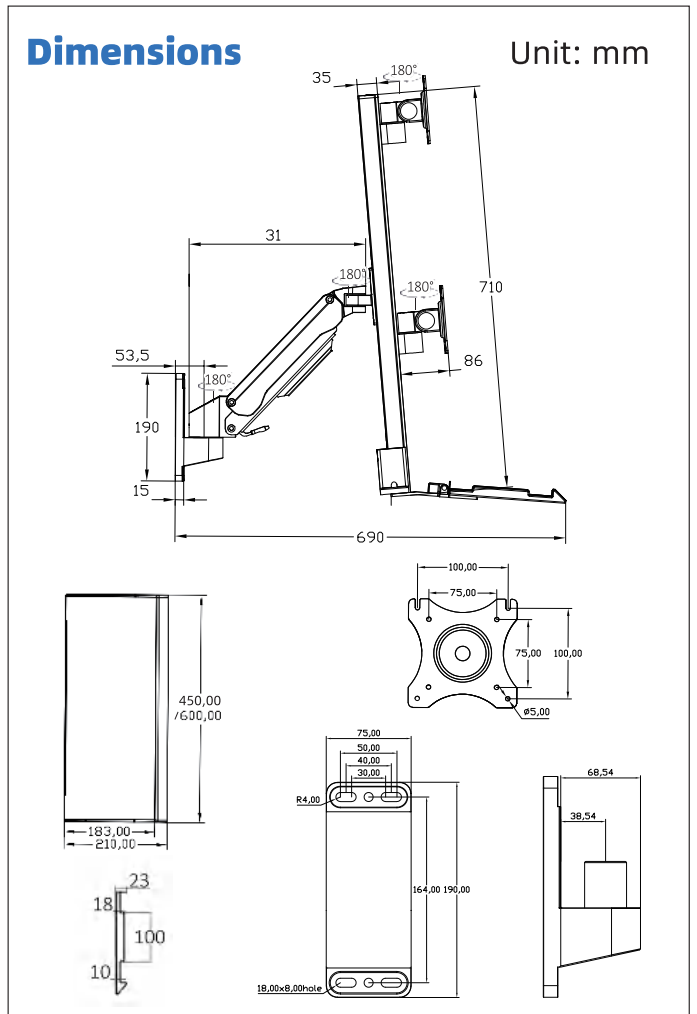

## Specifications

Complete System	Net Weight	~8kg (≈17.63lbs)	
	Colour	White/Silver	
	Material	Plastic/Aluminum	
Display System	Hinge Module	Swivel (VESA Hinge)	±90°
		Tilt (VESA Hinge)	-15° ~ + 35°
		Tilt (Keyboard)	0 ~ 90°
		Pivot	180°
		User Torque Adjust	Available
	Display Support	Mounting Pattern	100x100 / 75x75 mm
		Display Type	Singal Monitor
		Panel Size Support	≤32"
		Single Support Weight (VESA)	≤7.5kg (≤16.5lbs)
		Support Weight (Keyboard)	≤3kg(≤6.61lbs)
		Height Adjust	Height Adjustment Range
	Extended Arm	Tension Torque Adjust	Yes
		Tilt (Profile)	6°
		Extended Arm Provided	1
	Cable Management	Yes	

## Ordering Information









Product No.	KeyBoard Tray Size	Product Description
T8-GA01KB-SPB (Color Remarks)	450mm or 600mm (Note Remarks)	Workstation, support 32", ≤20kg, Arm with Keyboard tray, 75x75 / 100 x 100 mm

All product specifications are subject to change without notice

Last updated: 13-Apr-2025



PRODUCT NO: T8-GA02KB-SPB  ≤15kg

VESA	Tilt	Rotate	Swivel
100x100 75x75mm 	35° 15° 	360° 	180° 180° 
Cable Management	Air Pressure Rise and Fall	Height Adjust	Quick Installation Design
			

## Dimensions

Unit: mm

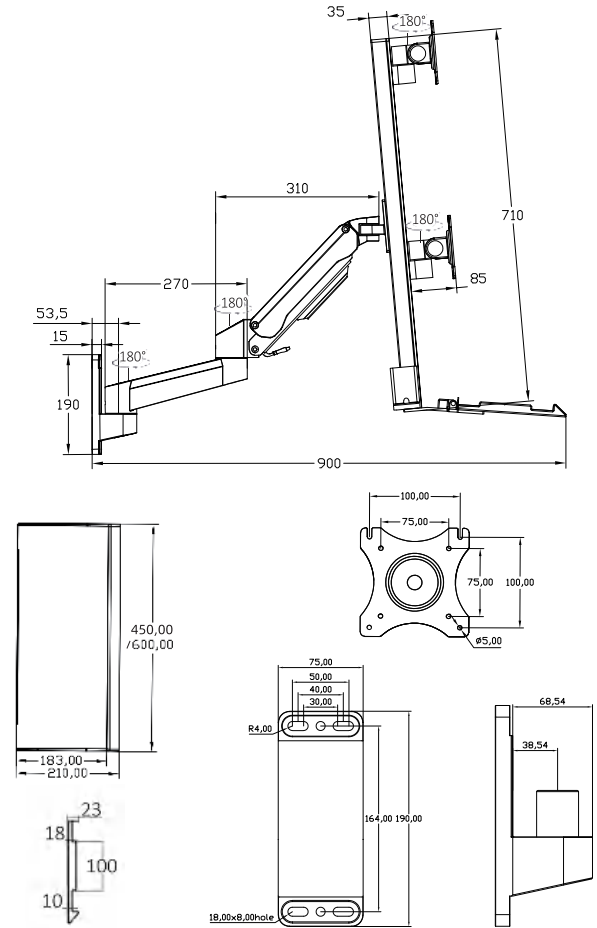

## Specifications







Complete System	Net Weight	~9kg (~19.84lbs)	
	Colour	White/Silver	
	Material	Plastic/Aluminum	
Display System	Hinge Module	Swivel (VESA Hinge)	±90°
		Tilt (VESA Hinge)	-15° ~ + 35°
		Tilt (Keyboard)	0 ~ 90°
		Pivot	180°
		User Torque Adjust	Available
	Display Support	Mounting Pattern	100x100 / 75x75 mm
		Display Type	Singal Monitor
		Panel Size Support	≤32"
		Single Support Weight (VESA)	≤6kg (≤13.22lbs)
		Support Weight (Keyboard)	≤3kg(≤6.61lbs)
		Height Adjust	Height Adjustment Range
	Extended Arm/Provided	Tension Torque Adjust	Yes
		Tilt (Profile)	6°
		Extended Arm/Provided	2
		Cable Management	Yes

## Ordering Information

Product No.	KeyBoard Tray Size	Product Description
T8-GA02KB-SPB (Color Remarks)	450mm or 600mm (Note Remarks)	Workstation, support 32", ≤20kg, Arm with Keyboard tray, 75x75 / 100 x 100 mm



PRODUCT NO: T8-MA00KB-SPB  ≤20kg

VESA	Tilt	Rotate	Swivel
100x100 75x75mm 	35° 15° 	360° 	180° 
Height Adjust  385mm	Quick Installation Design 		

**Dimensions**

Unit: mm

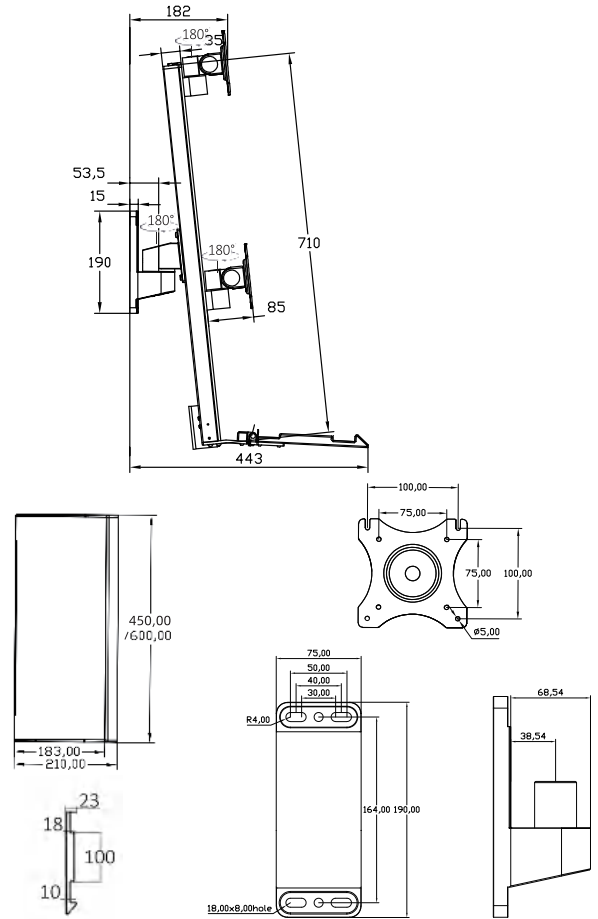

**Specifications**

Complete System	Net Weight	~6kg (≈13.22lbs)	
	Colour	White/Silver	
	Material	Plastic/Aluminum	
Display System	Hinge Module	Swivel (VESA Hinge)	±90°
		Tilt (VESA Hinge)	-15° ~ + 35°
		Tilt (Keyboard)	0 ~ 90°
		Pivot	180°
		User Torque Adjust	Available
	Display Support	Mounting Pattern	100x100 / 75x75 mm
		Display Type	Singal Monitor
		Panel Size Support	≤32"
		Single Support Weight (VESA)	≤7.5kg (≤16.5lbs)
		Support Weight (Keyboard)	≤3kg(≤6.61lbs)
Height Adjust	Height Adjustment Range (Monitor)	385mm(15.15")	
	Tension Torque Adjust	Yes	
	Tilt (Profile)	6°	
Extended Arm	Provided	0	
Cable Management		No	

**Ordering Information**







Product No.	KeyBoard Tray Size	Product Description
T8-MA00KB-SPB (Color Remarks)	450mm or 600mm (Note Remarks)	Workstation, support 32", ≤20kg, Arm with Keyboard tray, 75x75 / 100 x 100 mm

All product specifications are subject to change without notice

Last updated: 13-Apr-2025



PRODUCT NO: T8-MA01KB-SPB  ≤20kg

VESA	Tilt	Rotate	Swivel
100x100 75x75mm 	35° 15° 	360° 	180° 180° 
Cable Management	Height Adjust	Quick Installation Design	
	385mm 		

## Dimensions

Unit: mm

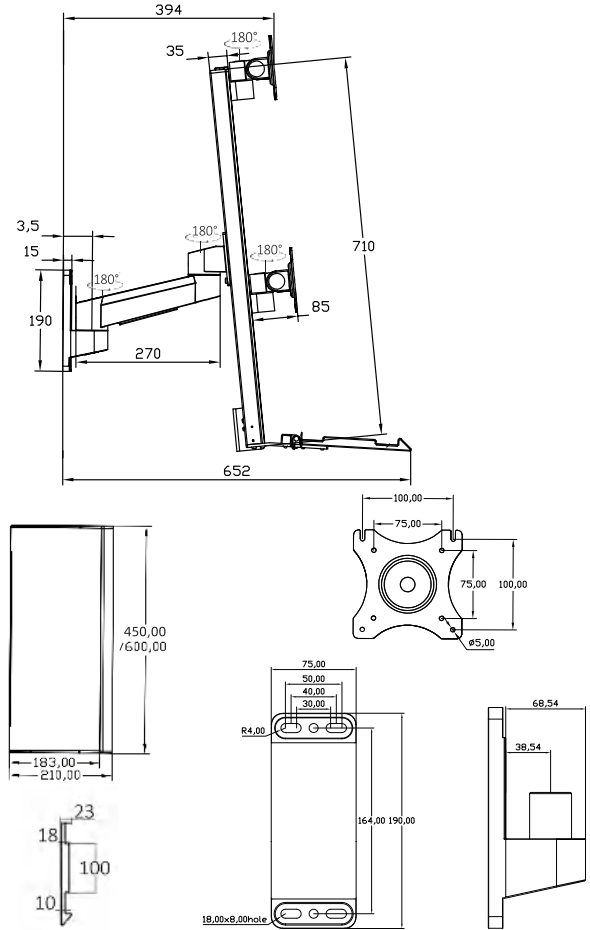

## Specifications

Complete System	Net Weight	~7kg (~15.43lbs)	
	Colour	White/Silver	
	Material	Plastic/Aluminum	
Display System	Hinge Module	Swivel (VESA Hinge)	±90°
		Tilt (VESA Hinge)	-15° ~ + 35°
		Tilt (Keyboard)	0 ~ 90°
		Pivot	180°
		User Torque Adjust	Available
	Display Support	Mounting Pattern	100x100 / 75x75 mm
		Display Type	Singal Monitor
		Panel Size Support	≤32"
		Single Support Weight (VESA)	≤7.5kg (≤16.5lbs)
		Support Weight (Keyboard)	≤3kg(≤6.61lbs)
Height Adjust	Height Adjustment Range (Monitor)	385mm(15.15")	
	Tension Torque Adjust	Yes	
	Tilt (Profile)	6°	
Extended Arm	Provided	1	
Cable Management		Yes	

## Ordering Information

Product No.	KeyBoard Tray Size	Product Description
T8-MA01KB-SPB (Color Remarks)	450mm or 600mm (Note Remarks)	Workstation, support 32", ≤20kg, Arm with Keyboard tray, 75x75 / 100 x 100 mm







All product specifications are subject to change without notice

Last updated: 13-Apr-2025





PRODUCT NO: T8-MA02KB-SPB  ≤15kg

VESA	Tilt	Rotate	Swivel
100x100 75x75mm 	35° 15° 	360° 	180° 180° 
Cable Management 	Height Adjust 385mm 	Quick Installation Design 	

**Dimensions**

Unit: mm

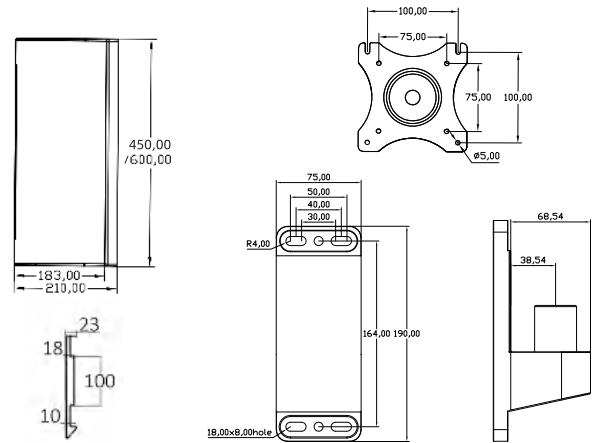
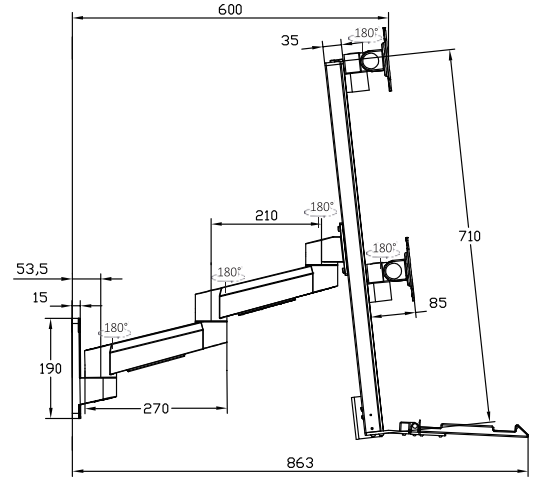

**Specifications**

Complete System	Net Weight	≈8kg (≈17.63lbs)		
	Colour	White/Silver		
	Material	Plastic/Aluminum		
Display System	Hinge Module	Swivel (VESA Hinge)	±90°	
		Tilt (VESA Hinge)	-15° ~ + 35°	
		Tilt (Keyboard)	0 ~ 90°	
		Pivot	180°	
		User Torque Adjust	Available	
	Display Support	Mounting Pattern	100x100 / 75x75 mm	
		Display Type	Singal Monitor	
		Panel Size Support	≤32"	
		Single Support Weight (VESA)	≤6kg (≤13.22lbs)	
		Support Weight (Keyboard)	≤3kg(≤6.61lbs)	
Height Adjust	Height Adjustment Range	385mm(15.15")		
	(Monitor)			
	Tension Torque Adjust	Yes		
	Tilt (Profile)	6°		
	Extended ArmProvided	2		
	Cable Management	Yes		

**Ordering Information**

Product No.	KeyBoard Tray Size	Product Description
T8-MA02KB-SPB (Color Remarks)	450mm or 600mm ( Note Remarks)	Workstation,support 32",≤15kg, Arm with Keyboard tray,75x75 / 100 x 100 mm

All product specifications are subject to change without notice

Last updated: 13-Apr-2025







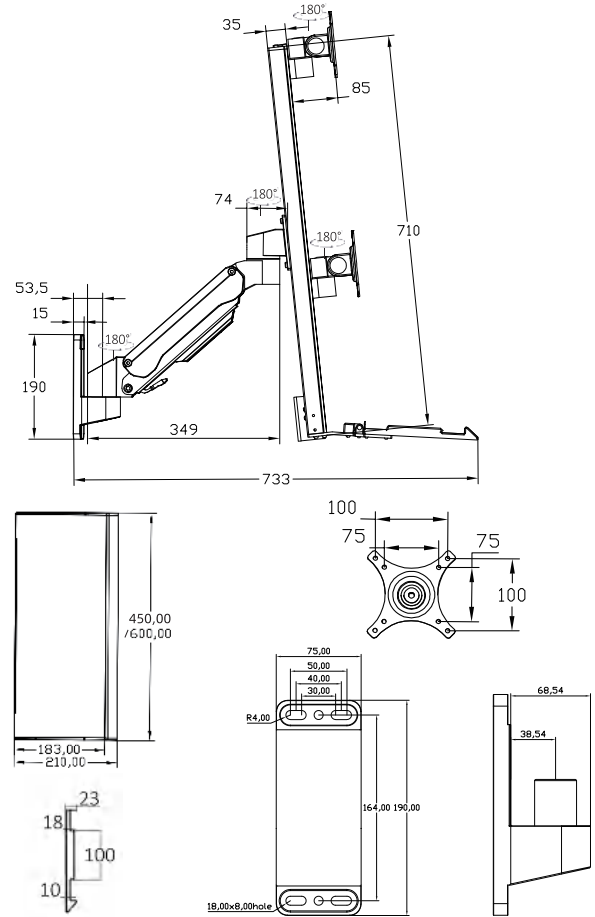



## Dimensions

Unit: mm



PRODUCT NO: T9-GA01KB-SPC  ≤20kg

VESA	Tilt	Rotate	Swivel
100x100 75x75mm 	35° 15° 	360° 	180° 180° 
Cable Management	Air Pressure Rise and Fall	Height Adjust	Quick Installation Design
	315mm 	385mm 	

## Specifications

Complete System	Net Weight	≈8.5kg (≈18.74lbs)	
	Colour	White/Silver	
	Material	Plastic/Aluminum	
Display System	Hinge Module	Swivel (VESA Hinge)	±90°
		Tilt (VESA Hinge)	-15° ~ + 35°
		Tilt (Keyboard)	0 ~ 90°
		Pivot	180°
		User Torque Adjust	Available
	Display Support	Mounting Pattern	100x100 / 75x75 mm
		Display Type	Singal Monitor
		Panel Size Support	≤32"
		Single Support Weight (VESA)	≤7.5kg (≤16.5lbs)
		Support Weight (Keyboard)	≤3kg(≤6.61lbs)
		Height Adjustment Range	385mm(15.15") / 315mm(12.40")
		Height Adjust	(Monitor) / (Arm)
	Tension Torque Adjust		Yes
	Tilt (Profile)		6°
	Extended Arm Provided		1
Cable Management		Yes	

## Ordering Information







Product No.	KeyBoard Tray Size	Product Description
T9-GA01KB-SPC (Color Remarks)	450mm or 600mm (Note Remarks)	Workstation,support 32",≤20kg, Arm with Keyboard tray,75x75 / 100 x 100 mm

All product specifications are subject to change without notice

Last updated: 13-Apr-2025



PRODUCT NO: T9-GA02KB-SPC  ≤20kg

VESA	Tilt	Rotate	Swivel
100x100 75x75mm 	35° 15° 	360° 	180° 180° 
Cable Management	Air Pressure Rise and Fall	Height Adjust	Quick Installation Design
	 315mm	 385mm	

**Dimensions**

Unit: mm

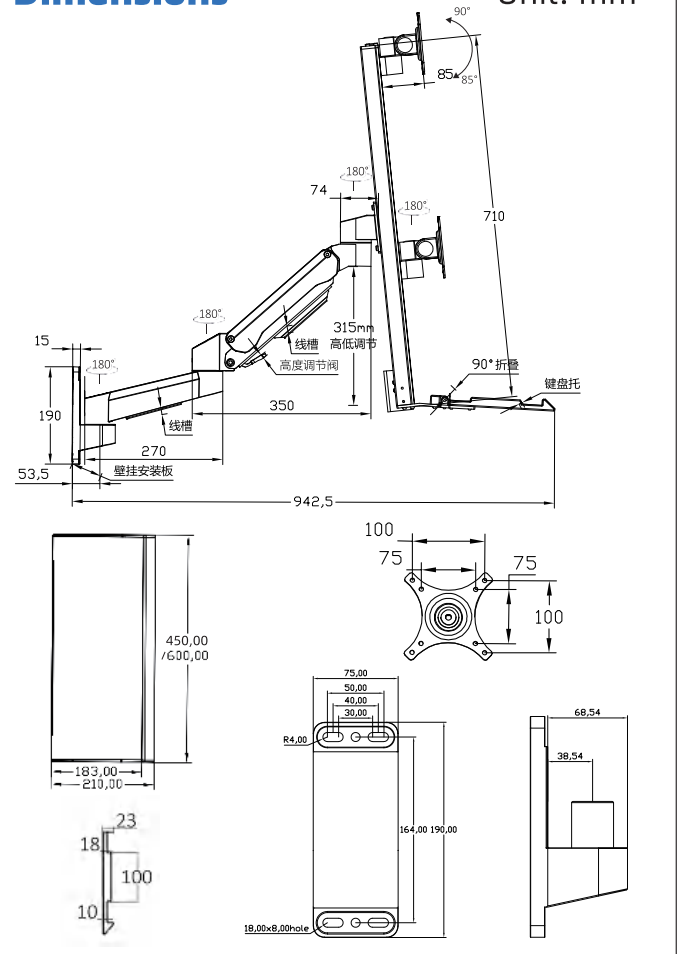

**Specifications**

Complete System	Net Weight	≈9.5kg (≈20.94lbs)	
	Colour	White/Silver	
	Material	Plastic/Aluminum	
Display System	Hinge Module	Swivel (VESA Hinge)	±90°
		Tilt (VESA Hinge)	-15° ~ +35°
		Tilt (Keyboard)	0 ~ 90°
		Pivot	180°
		User Torque Adjust	Available
	Display Support	Mounting Pattern	100x100 / 75x75 mm
		Display Type	Singal Monitor
		Panel Size Support	≤32"
		Single Support Weight (VESA)	≤7kg (≤15.43lbs)
		Support Weight (Keyboard)	≤3kg(≤6.61lbs)
Height Adjust	Height Adjustment Range (Monitor) / (Arm)	385mm(15.15") / 315mm(12.40")	
	Tension Torque Adjust	Yes	
	Tilt (Profile)	6°	
Extended Arm Provided		2	
Cable Management		Yes	

**Ordering Information**

Product No.	KeyBoard Tray Size	Product Description
T9-GA02KB-SPC (Color Remarks)	450mm or 600mm (Note Remarks)	Workstation,support 32",≤20kg, Arm with Keyboard tray,75x75 / 100 x 100 mm

All product specifications are subject to change without notice

Last updated: 13-Apr-2025



PRODUCT NO: BDT-01

≤10kg

VESA	Tilt	Rotate	Swivel
100x100 75x75mm 	35° 15° 	360° 	180° / 90° 180° / 90° 
Cable Management 	Air Pressure Rise and Fall 700mm 		

## Dimensions

Unit: mm

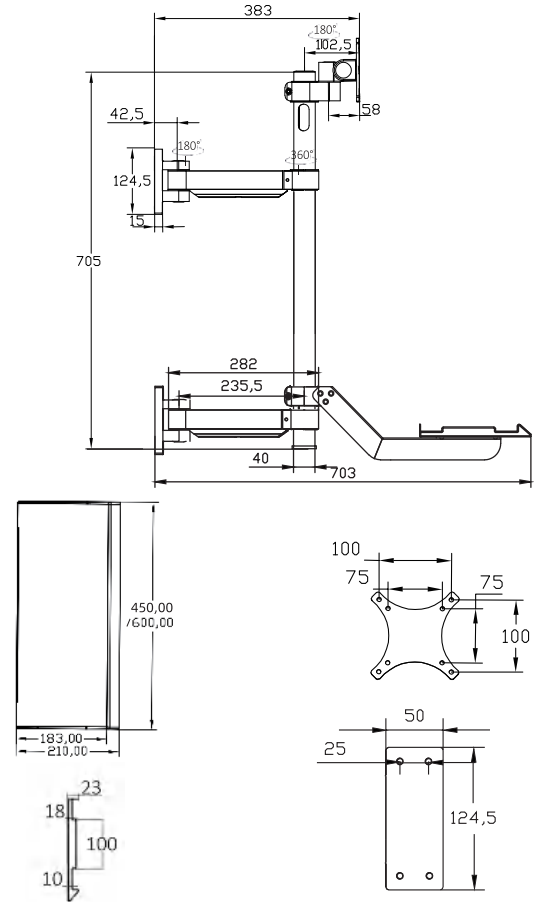

## Specifications

Complete System	Net Weight	~5kg (≈11.02lbs)	
	Colour	Surface Anode	
	Material	Plastic/Aluminum	
Display System	Hinge Module	Swivel (VESA Hinge)	±90°
		Tilt (VESA Hinge)	-15° ~ + 35°
		Tilt (Keyboard)	0 ~ 90°
		Pivot	360°
		User Torque Adjust	Available
	Display Support	Mounting Pattern	100x100 / 75x75 mm
		Display Type	Singal Monitor
		Panel Size Support	≤32"
		Single Support Weight (VESA)	≤7kg (≤15.43lbs)
		Support Weight (Keyboard)	≤3kg(≤6.61lbs)
Height Adjust	Height Adjustment Range	700mm(27.55")	
	(Monitor ) / (Arm)		
	Tension Torque Adjust	Yes	
	Extended ArmProvided	2	
	Cable Management	Yes	

## Ordering Information

Product No.	KeyBoard Tray Size	Product Description
BDT-01	450mm or 600mm ( Note Remarks )	Workstation,support 32",≤10kg, Arm with Keyboard tray,75x75 / 100 x 100 mm

All product specifications are subject to change without notice

Last updated: 13-Apr-2025











**Dimensions**

Unit: mm

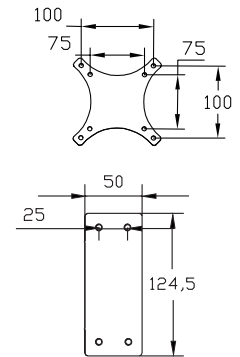
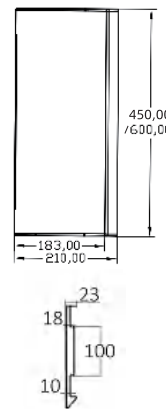
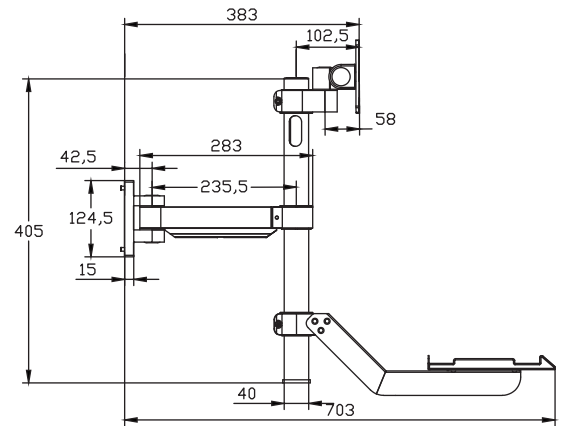

PRODUCT NO: BDT-02

≤10kg

VESA	Tilt	Rotate	Swivel
100x100 75x75mm 	35° 15° 	360° 	80° / 100° 160° / 180° 
Cable Management 	Air Pressure Rise and Fall 400mm 		

**Specifications**

Complete System	Net Weight	≈4.5kg (≈9.92lbs)	
	Colour	Surface Anode	
	Material	Plastic/Aluminum	
Display System	Hinge Module	Swivel (VESA Hinge)	±90°
		Tilt (VESA Hinge)	-15° ~ + 35°
		Tilt (Keyboard)	0 ~ 90°
		Pivot	360°
		User Torque Adjust	Available
	Display Support	Mounting Pattern	100x100 / 75x75 mm
		Display Type	Singal Monitor
		Panel Size Support	≤32"
		Single Support Weight (VESA)	≤7kg (≤15.43lbs)
		Support Weight (Keyboard)	≤3kg(≤6.61lbs)
Height Adjust	Height Adjustment Range	700mm(27.55")	
	(Monitor ) / (Arm)		
	Tension Torque Adjust	Yes	
	Extended Arm Provided	1	
	Cable Management	Yes	

**Ordering Information**

Product No.	KeyBoard Tray Size	Product Description
BDT-02	450mm or 600mm ( Note Remarks )	Workstation,support 32",≤10kg, Arm with Keyboard tray,75x75 / 100 x 100 mm

All product specifications are subject to change without notice

Last updated: 13-Apr-2025



PRODUCT NO: BDT-03

≤10kg

VESA	Tilt	Rotate	Swivel
100x100 75x75mm 	35° 15° 	360° 	180° / 180° 
Cable Management 	Air Pressure Rise and Fall 700mm 		

## Dimensions

Unit: mm

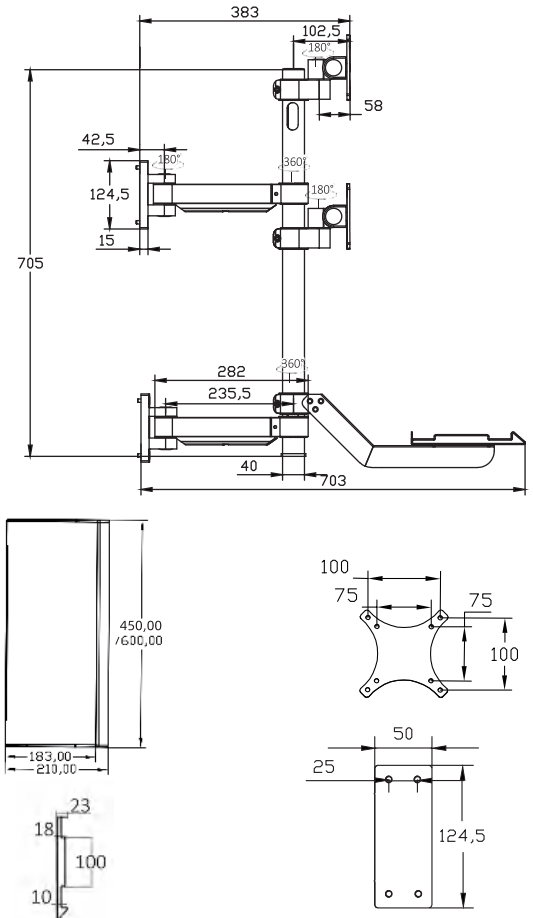

## Specifications

Complete System	Net Weight	≈6kg (≈13.22lbs)	
	Colour	Surface Anode	
	Material	Plastic/Aluminum	
Display System	Hinge Module	Swivel (VESA Hinge)	±90°
		Tilt (VESA Hinge)	-15° ~ + 35°
		Tilt (Keyboard)	0 ~ 90°
		Pivot	360°
		User Torque Adjust	Available
	Display Support	Mounting Pattern	100x100 / 75x75 mm
		Display Type	Singal Monitor
		Panel Size Support	≤32"
		Single Support Weight (VESA)	≤7kg (≤15.43lbs)
		Support Weight (Keyboard)	≤3kg(≤6.61lbs)
Height Adjust	Height Adjustment Range	700mm(27.55")	
	(Monitor ) / (Arm)		
	Tension Torque Adjust	Yes	
	Extended ArmProvided	2	
	Cable Management	Yes	

## Ordering Information

Product No.	KeyBoard Tray Size	Product Description
BDT-03	450mm or 600mm ( Note Remarks )	Workstation,support 32",≤10kg, Arm with Keyboard tray,75x75 / 100 x 100 mm

All product specifications are subject to change without notice

Last updated: 13-Apr-2025