



**Features:**

- Interdigitated amplifying gates
- Fast turn-on and high di/dt
- Low switching losses
- Short turn-off time
- Hermetic metal cases with ceramic insulators

**Typical Applications**

- Inductive heating
- Electronic welders
- Self-commutated inverters
- AC motor speed control

**Part No. Y50KAD-KT50cT**

<b>I<sub>T(AV)</sub></b>	<b>1260A</b>
<b>V<sub>DRM</sub>, V<sub>RRM</sub></b>	<b>1200V 1400V</b>
<b>t<sub>q</sub></b>	<b>12~28μs</b>

SYMBOL	CHARACTERISTIC	TEST CONDITIONS	T <sub>J</sub> (°C)	VALUE			UNIT
				Min	Type	Max	
I <sub>T(AV)</sub>	Mean on-state current	180° half sine wave 50Hz Double side cooled,	T <sub>C</sub> =55°C 125			1260	A
V <sub>DRM</sub> V <sub>RRM</sub>	Repetitive peak off-state voltage Repetitive peak reverse voltage	tp=10ms	125	1100		1400	V
I <sub>DRM</sub> I <sub>RRM</sub>	Repetitive peak off-state current Repetitive peak reverse current	at V <sub>DRM</sub> at V <sub>RRM</sub>	125			80	mA
I <sub>TSM</sub>	Surge on-state current	10ms half sine wave	125			16.3	kA
I <sup>2</sup> t	I <sup>2</sup> T for fusing coordination	V <sub>R</sub> =0.6V <sub>RRM</sub>				1328	A <sup>2</sup> s*10 <sup>3</sup>
V <sub>TO</sub>	Threshold voltage		125			1.65	V
r <sub>T</sub>	On-state slop resistance					0.36	mΩ
V <sub>TM</sub>	Peak on-state voltage	I <sub>TM</sub> =2400A, F=24kN	25			3.20	V
dv/dt	Critical rate of rise of off-state voltage	V <sub>DM</sub> =0.67V <sub>DRM</sub>	125			1000	V/μs
di/dt	Critical rate of rise of on-state current	V <sub>DM</sub> = 67%V <sub>DRM</sub> , to2000A Gate pulse t <sub>r</sub> ≤0.5μs I <sub>GM</sub> =1.5A	125			1500	A/μs
Q <sub>rr</sub>	Recovery charge	I <sub>TM</sub> =1000A, tp=4000μs, di/dt=-20A/μs, V <sub>R</sub> =100V	125		87	100	μC
t <sub>q</sub>	Circuit commutated turn-off time	I <sub>TM</sub> =1000A, tp=4000μs, V <sub>R</sub> =100V dv/dt=30V/μs, di/dt=-20A/μs	125	12		28	μs
I <sub>GT</sub>	Gate trigger current	V <sub>A</sub> =12V, I <sub>A</sub> =1A	25	30		250	mA
V <sub>GT</sub>	Gate trigger voltage			0.8		3.0	V
I <sub>H</sub>	Holding current			20		400	mA
I <sub>L</sub>	Latching current					500	mA
V <sub>GD</sub>	Non-trigger gate voltage	V <sub>DM</sub> =67%V <sub>DRM</sub>	125			0.3	V
R <sub>th(j-c)</sub>	Thermal resistance Junction to case	At 180° sine double side cooled Clamping force 24kN				0.020	°C /W
R <sub>th(c-h)</sub>	Thermal resistance case to heat sink					0.005	
F <sub>m</sub>	Mounting force			19		26	kN
T <sub>vj</sub>	Junction temperature			-40		125	°C
T <sub>stg</sub>	Stored temperature			-40		140	°C
W <sub>i</sub>	Weight				440		g
Outline	KT50cT						

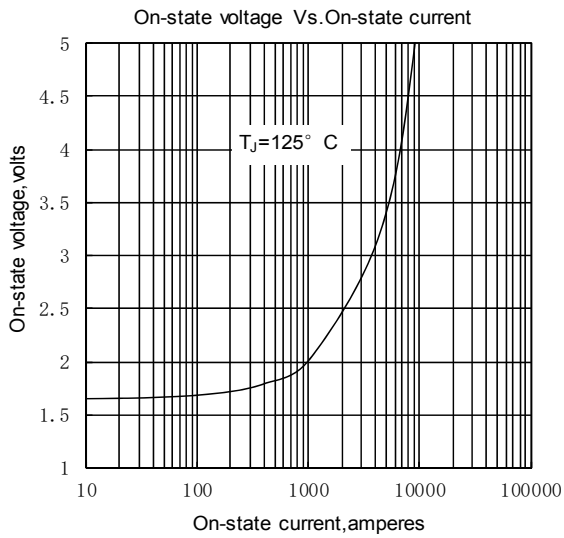

Fig. 1

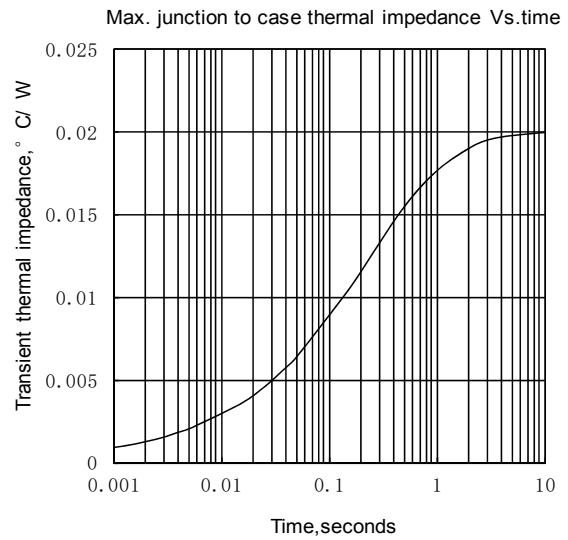

Fig. 2

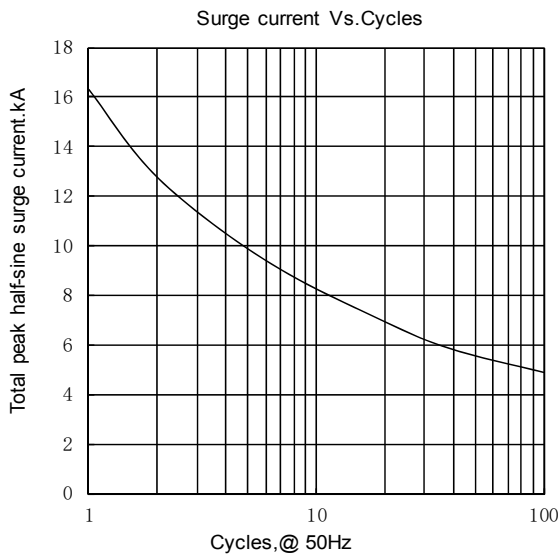

Fig. 3

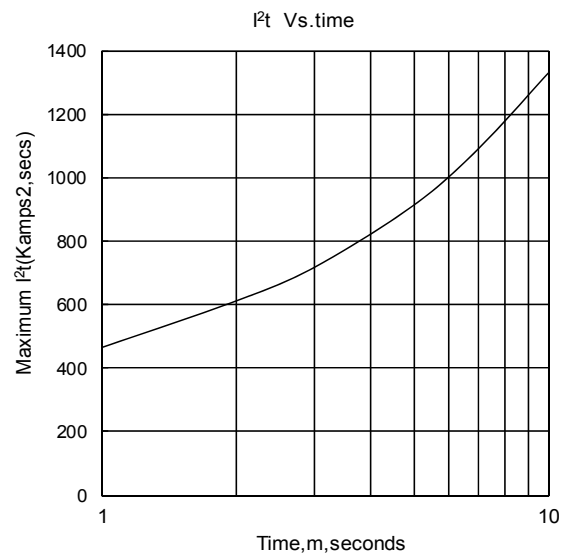

Fig. 4

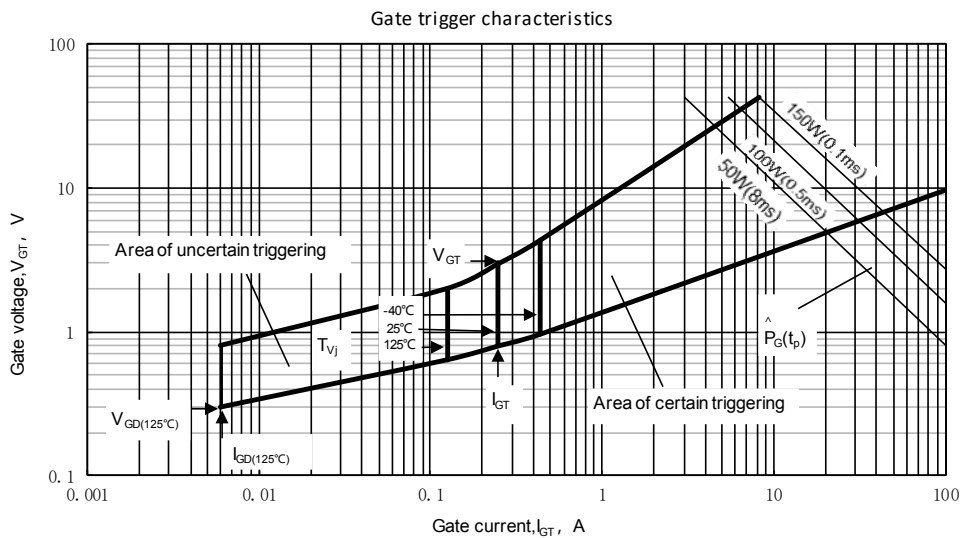
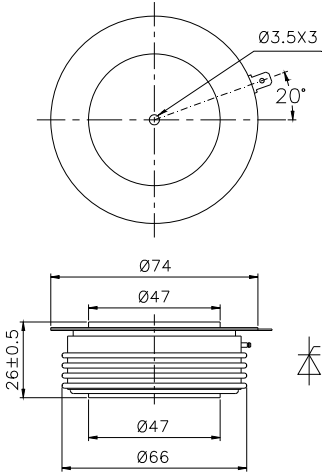

Fig.5

Outline:



TECHSEM reserves the right to change specifications without notice.