

Features :

- Interdigitated amplifying gates
- Fast turn-on and high di/dt
- Low switching losses
- Short turn-off time
- Hermetic metal cases with ceramic insulators

Typical Applications

- Inductive heating
- Electronic welders
- Self-commutated inverters
- AC motor speed control

Part No. Y45KKD-KT44cT		
I_{T(AV)}	1010A	
V_{DRM}, V_{RRM}	1200V	1400V
	1600V	
t_q	18~36μs	

SYMBOL	CHARACTERISTIC	TEST CONDITIONS	T _J (°C)	VALUE			UNIT	
				Min	Type	Max		
I _{T(AV)}	Mean on-state current	180° half sine wave 50Hz Double side cooled, T _C =55°C	125			1010	A	
V _{DRM} V _{RRM}	Repetitive peak off-state voltage Repetitive peak reverse voltage	tp=10ms	125	1200		1600	V	
I _{DRM} I _{RRM}	Repetitive peak off-state current Repetitive peak reverse current	at V _{DRM} at V _{RRM}	125			50	mA	
I _{TSM}	Surge on-state current	10ms half sine wave	125			11	kA	
I ² t	I ² t for fusing coordination	V _R =0.6V _{RRM}				605	A ² s*10 ³	
V _{TO}	Threshold voltage		125			1.70	V	
r _T	On-state slope resistance					0.48	mΩ	
V _{TM}	Peak on-state voltage	I _{TM} =1800A, F=21kN	25			3.20	V	
dv/dt	Critical rate of rise of off-state voltage	V _{DM} =0.67V _{DRM}	125			1000	V/μs	
di/dt	Critical rate of rise of on-state current	V _{DM} = 67%V _{DRM} to 1600A, Gate pulse t _r ≤0.5μs I _{GM} =1.5A	125			1500	A/μs	
Q _{rr}	Recovery charge	I _{TM} =1000A, tp=4000μs, di/dt=-20A/μs, V _R =100V	125		83	100	μC	
t _q	Circuit commutated turn-off time	I _{TM} =1000A, tp=4000μs, V _R =100V dv/dt=30V/μs, di/dt=-20A/μs	125	18		36	μs	
I _{GT}	Gate trigger current	V _A =12V, I _A =1A	25			30	mA	
V _{GT}	Gate trigger voltage					0.8	3.0	V
I _H	Holding current					20	400	mA
I _L	Latching current						500	mA
V _{GD}	Non-trigger gate voltage	V _{DM} =67%V _{DRM}	125			0.3	V	
R _{th(j-c)}	Thermal resistance Junction to case	At 180° sine double side cooled Clamping force 21kN				0.024	°C /W	
R _{th(c-h)}	Thermal resistance case to heat sink					0.006		
F _m	Mounting force			18		25	kN	
T _{vj}	Junction temperature			-40		125	°C	
T _{stg}	Stored temperature			-40		140	°C	
W _t	Weight					3800	g	
Outline	KT44cT							

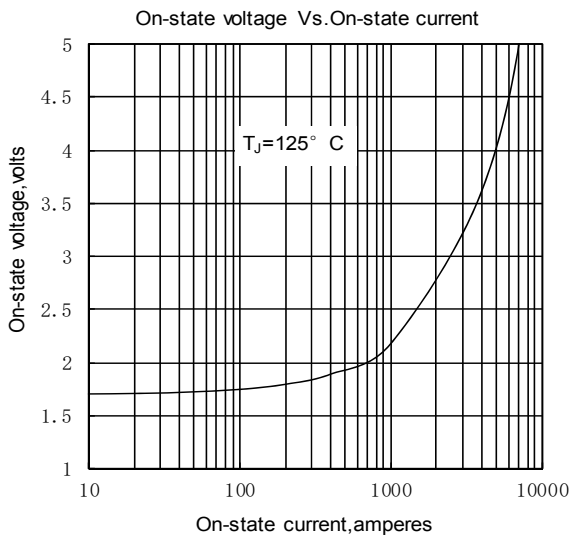

Fig. 1

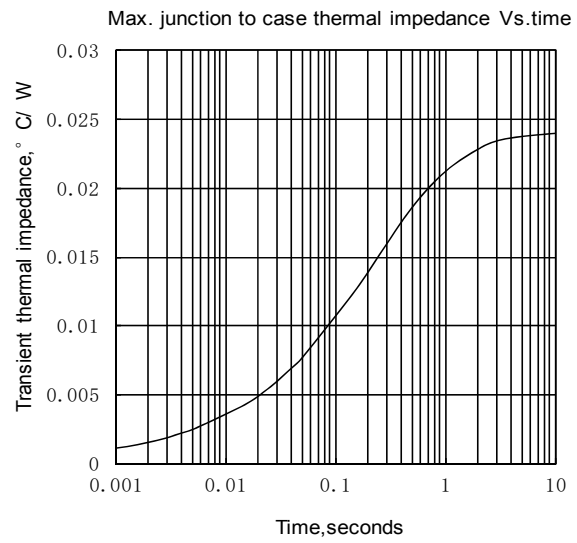

Fig. 2

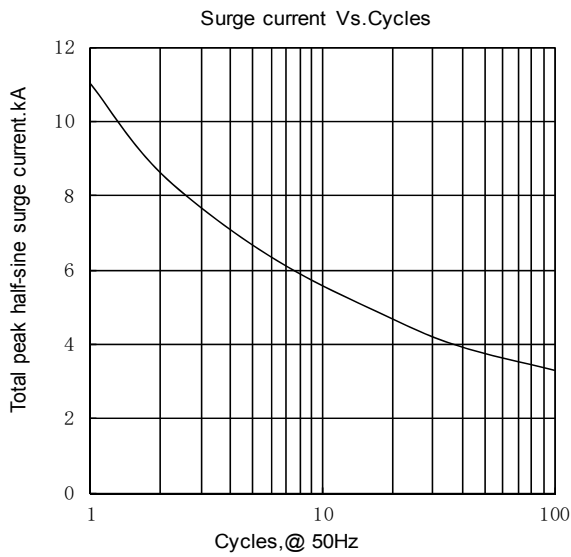

Fig. 3

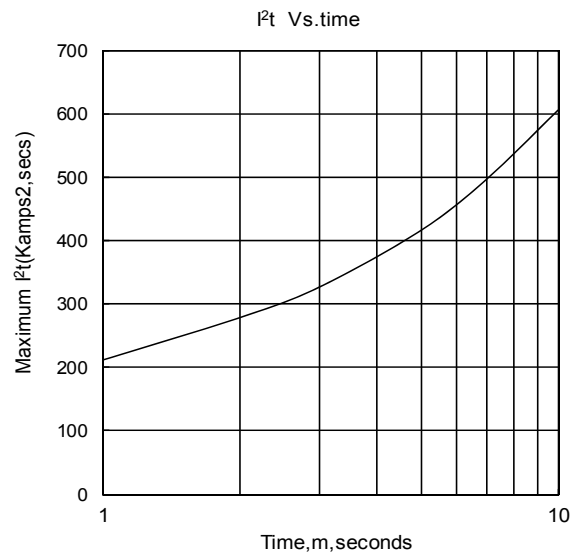

Fig. 4

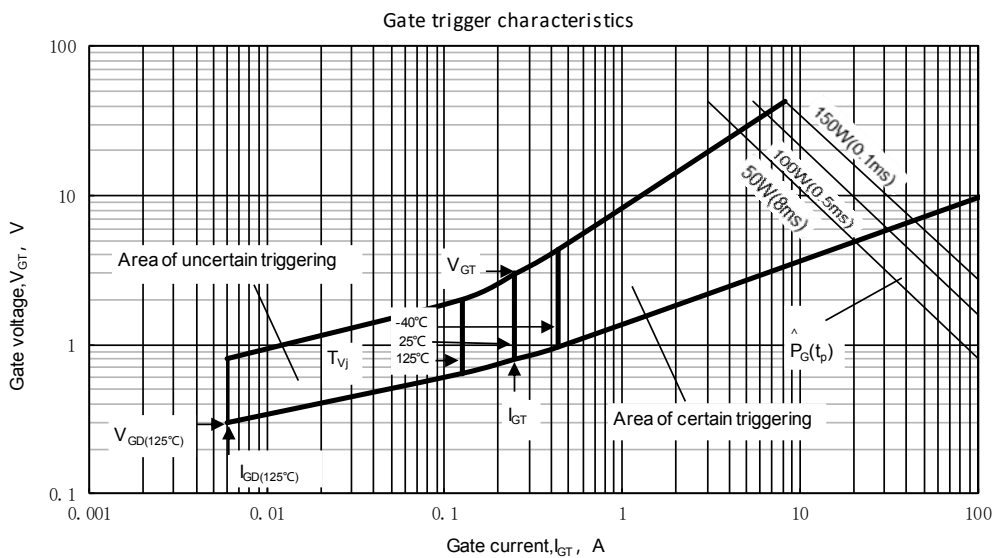
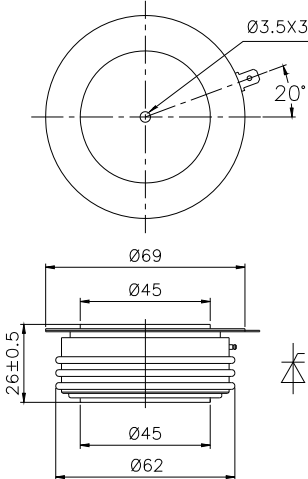

Fig.5

Outline:



TECHSEM reserves the right to change specifications without notice.