**Features**

- n Interdigitated amplifying gates
- n Fast turn-on and high di/dt
- n Low switching losses

Typical Applications

- n Design for inverter supply application

Part No. Y70KFG-KT60c(d)T

I_{T(AV)}	2206A
V_{DRM}	2000V~3000V
V_{RRM}	1000V~2500V
t_q	20~75μs

SYMBOL	CHARACTERISTIC	TEST CONDITIONS	T _j (°C)	VALUE			UNIT	
				Min	Type	Max		
I _{T(AV)}	Mean on-state current	180° half sine wave 50Hz Double side cooled,	125			2608	A	
		T _C =55°C				2206		
V _{DRM}	Repetitive peak off-state voltage	tp=10ms	125	2000		3000	V	
V _{RRM}	Repetitive peak reverse voltage			1000		2500		
I _{DRM} I _{RRM}	Repetitive peak current	at V _{DRM} at V _{RRM}	125			200	mA	
I _{TSM}	Surge on-state current	10ms half sine wave	125			28	kA	
I ² t	I ² T for fusing coordination	V _R =0.6V _{RRM}				3920	A ² s*10 ³	
V _{TO}	Threshold voltage		125			1.21	V	
r _T	On-state slop resistance					0.16	mΩ	
V _{TM}	Peak on-state voltage	I _{TM} =4000A, F=32kN	25			2.60	V	
				20 ≤ tq ≤ 45			2.40	V
				46 ≤ tq ≤ 60			2.20	V
61 ≤ tq ≤ 75					2.20	V		
dv/dt	Critical rate of rise of off-state voltage	V _{DM} =0.67V _{DRM}	125			1000	V/μs	
di/dt	Critical rate of rise of on-state current	V _{DM} = 67%V _{DRM} to3000A Gate pulse t _r ≤ 0.5μs I _{GM} =1.5A	125			1500	A/μs	
Q _{rr}	Recovery charge	I _{TM} =2000A, tp=4000μs, di/dt=-20A/μs, V _R =100V	125		1200		μC	
t _q	Circuit commutated turn-off time	I _{TM} =2000A, tp=4000μs, V _R =100V dv/dt=30V/μs, di/dt=-20A/μs	100	20		75	μs	
I _{GT}	Gate trigger current	V _A =12V, I _A =1A	25	45		300	mA	
V _{GT}	Gate trigger voltage			0.9		4.5	V	
I _H	Holding current			20		500	mA	
I _L	Latching current					1000	mA	
V _{GD}	Non-trigger gate voltage	V _{DM} =67%V _{DRM}	125			0.3	V	
R _{th(j-c)}	Thermal resistance Junction to case	At 180° sine double side cooled Clamping force 40kN				0.012	°C /W	
R _{th(c-h)}	Thermal resistance case to heat sink					0.003		
F _m	Mounting force			30		40	kN	
T _{vj}	Junction temperature			-40		125	°C	
T _{stg}	Stored temperature			-40		140	°C	
W _t	Weight				880/ 1140		g	
Outline	KT60cT;KT60dT							

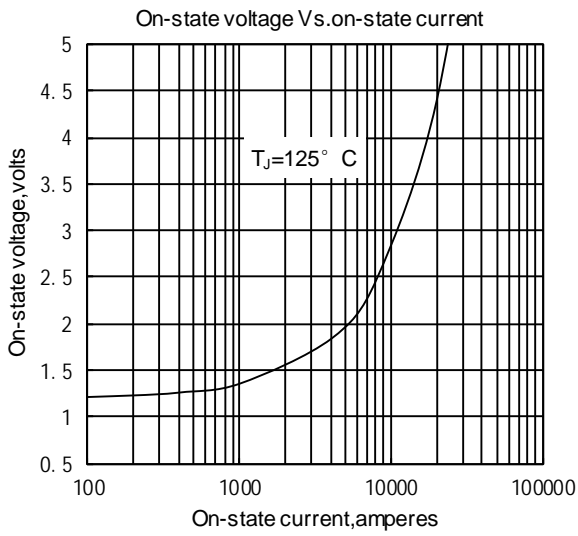

Fig.1

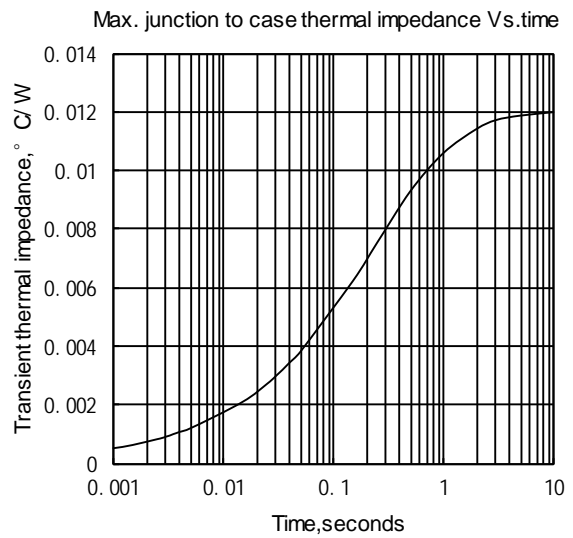

Fig.2

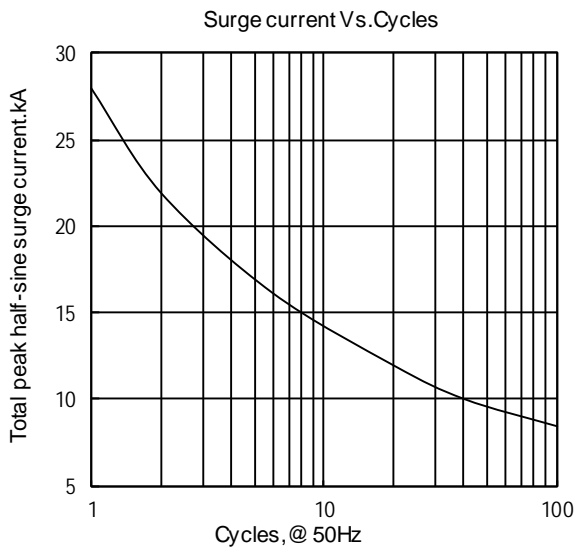

Fig.3

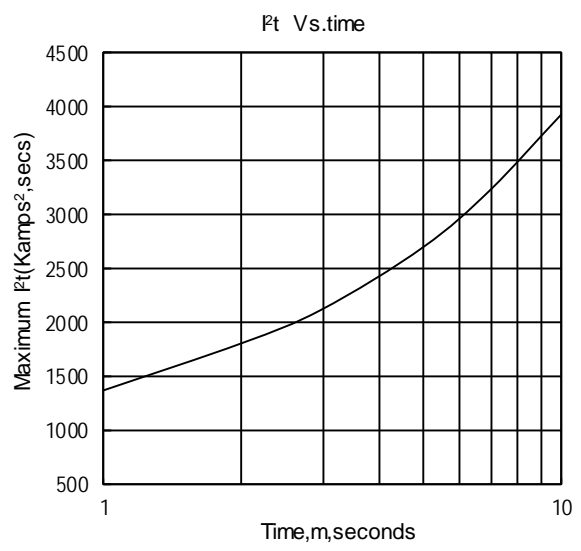

Fig.4

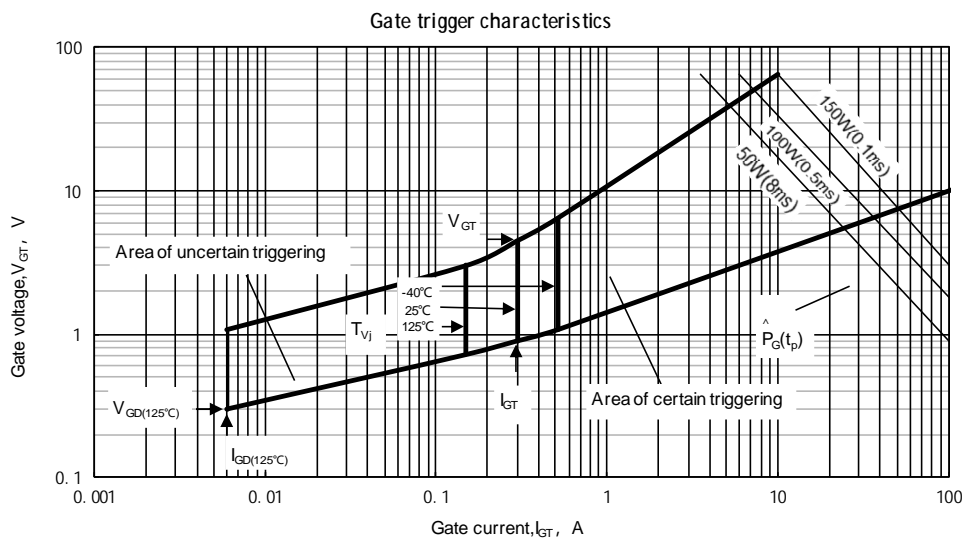
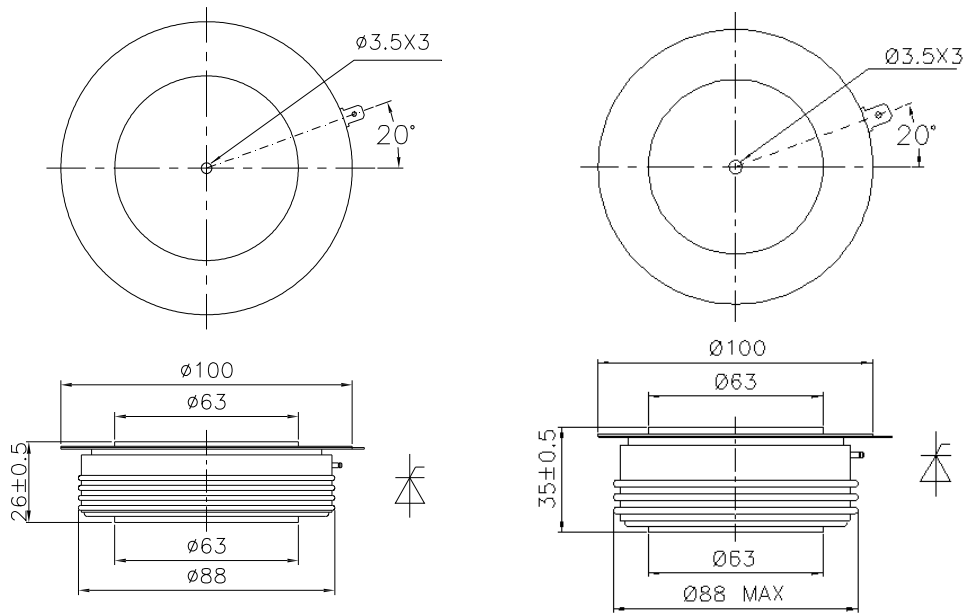

Fig.5

Outline:



TECHSEM reserves the right to change specifications without notice.