

**Features:**

- n Isolated mounting base 2500V~
- n Pressure contact technology with Increased power cycling capability
- n Space and weight saving

**Typical Applications:**

- n Inverter
- n Inductive heating
- n Chopper

V <sub>RRM</sub> , V <sub>DRM</sub>	Type & Outline	
600V	MKx250-06-415F3	MHx250-06-415F3
800V	MKx250-08-415F3	MHx250-08-415F3
1000V	MKx250-10-415F3	MHx250-10-415F3
1200V	MKx250-12-415F3	MHx250-12-415F3
1400V	MKx250-14-415F3	MHx250-14-415F3
1600V	MKx250-16-415F3	MHx250-16-415F3
1800V	MKx250-18-415F3	MHx250-18-415F3
1800V	MK250-18-415F3G	

MKx stands for any type of **MKC, MKA, MKK**  
 MHx stands for any type of **MHC, MHA, MHK**

SYMBOL	CHARACTERISTIC	TEST CONDITIONS	T <sub>j</sub> (°C)	VALUE			UNIT	
				Min	Type	Max		
I <sub>T(AV)</sub>	Mean on-state current	180° half sine wave 50Hz Single side cooled, T <sub>c</sub> =85°C	125			250	A	
I <sub>T(RMS)</sub>	RMS on-state current					392	A	
I <sub>DRM</sub> I <sub>RRM</sub>	Repetitive peak current	at V <sub>DRM</sub> at V <sub>RRM</sub>	125			80	mA	
I <sub>TSM</sub>	Surge on-state current	10ms half sine wave V <sub>R</sub> =60%V <sub>RRM</sub>	125			5.60	kA	
I <sup>2</sup> t	I <sup>2</sup> t for fusing coordination					157	10 <sup>3</sup> A <sup>2</sup> s	
V <sub>TO</sub>	Threshold voltage		125			1.30	V	
r <sub>T</sub>	On-state slope resistance					0.38	m	
V <sub>TM</sub>	Peak on-state voltage	I <sub>TM</sub> =750A	25			2.69	V	
dv/dt	Critical rate of rise of off-state voltage	V <sub>DM</sub> =67%V <sub>DRM</sub>	125			800	V/μs	
di/dt	Critical rate of rise of on-state current	Gate source 1.5A t <sub>r</sub> ≤0.5μs Repetitive	125			200	A/μs	
t <sub>q</sub>	Circuit commutated turn-off time	I <sub>TM</sub> =300A, t <sub>p</sub> =4000μs, V <sub>R</sub> =100V dv/dt=30V/μs, di/dt=-20A/μs	125	20		40	μs	
			25	6		16	μs	
I <sub>GT</sub>	Gate trigger current	V <sub>A</sub> =12V, I <sub>A</sub> =1A	25			30	mA	
V <sub>GT</sub>	Gate trigger voltage					0.8	3.0	V
I <sub>H</sub>	Holding current					20	200	mA
I <sub>L</sub>	Latching current						1000	mA
V <sub>GD</sub>	Non-trigger gate voltage	V <sub>DM</sub> = 67%V <sub>DRM</sub>	125			0.2	V	
R <sub>th(j-c)</sub>	Thermal resistance Junction to case	Single side cooled per chip				0.100	°C /W	
R <sub>th(c-h)</sub>	Thermal resistance case to heatsink	Single side cooled per chip				0.040	°C /W	
V <sub>iso</sub>	Isolation voltage	50Hz, R.M.S, t=1min, I <sub>iso</sub> :1mA(MAX)		2500			V	
F <sub>m</sub>	Terminal connection torque(M10)			10.0		12.0	N·m	
	Mounting torque(M6)			4.5		6.0	N·m	
T <sub>vj</sub>	Junction temperature			-40		125	°C	
T <sub>stg</sub>	Stored temperature			-40		125	°C	
W <sub>t</sub>	Weight				1260		g	
Outline	415F3							

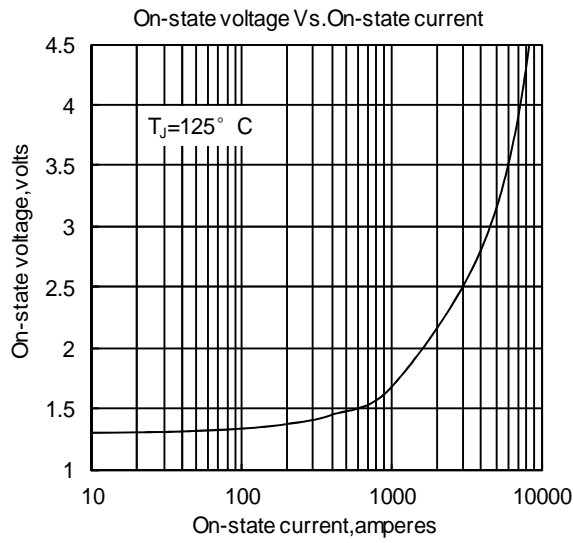

Fig.1

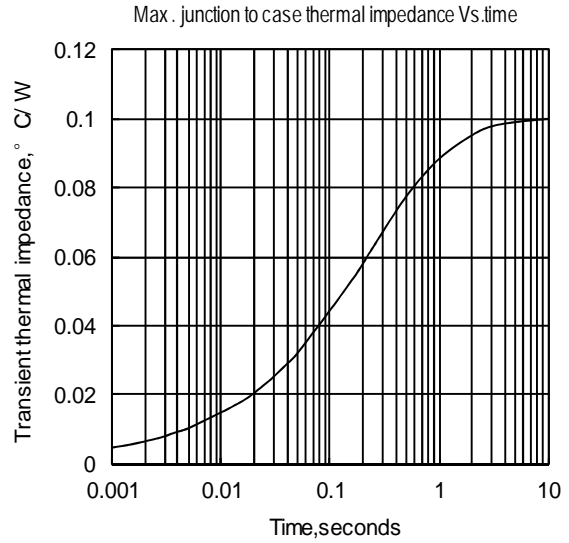

Fig.2

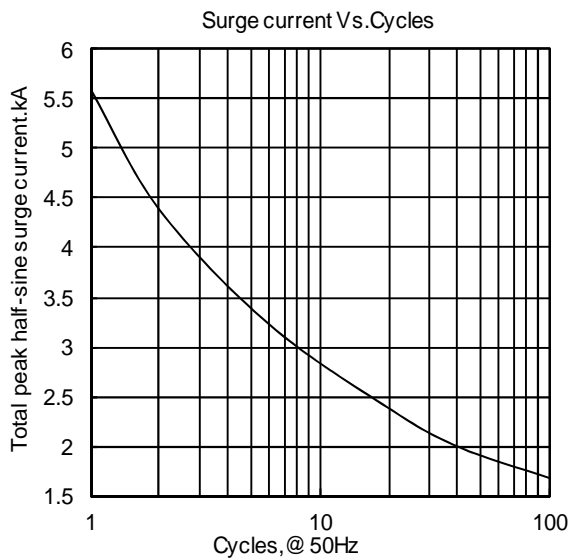

Fig.3

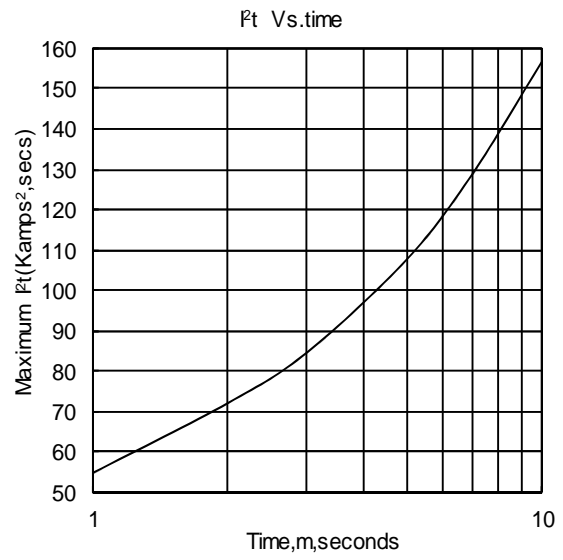

Fig.4

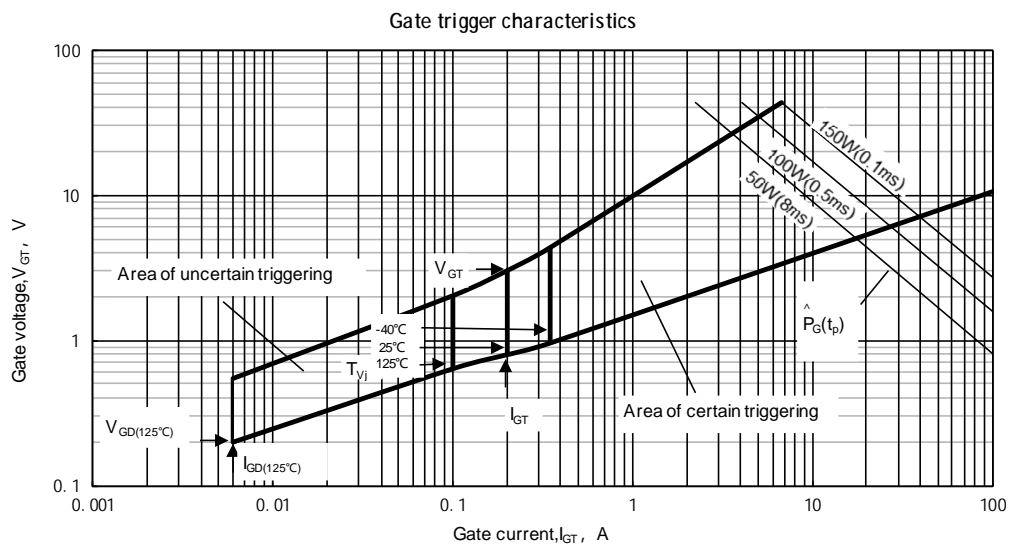
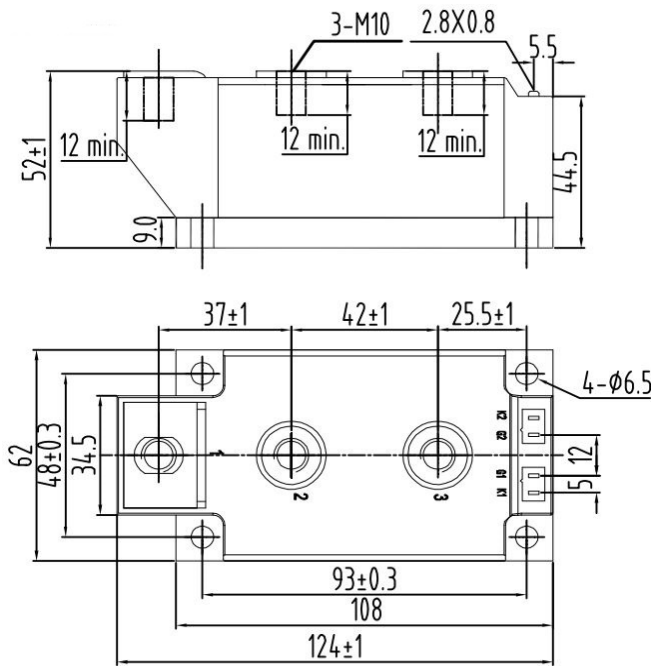

Fig.5

Outline:



Unmarked dimensional tolerance:  $\pm 0.5$ mm

TECHSEM reserves the right to change specifications without notice.

