

Features

- n Interdigitated amplifying gates
- n Fast turn-on and high di/dt
- n Low switching losses

Typical Applications

- n Inductive heating
- n Electronic welders
- n Self-commutated inverters

Part No. Y70KFE-KT60cT

I_{T(AV)}	2500A
V_{DRM}	800V~2000V
V_{RRM}	1000V~1800V
t_q	15~75µs

SYMBOL	CHARACTERISTIC	TEST CONDITIONS		T _j (°C)	VALUE			UNIT
					Min	Type	Max	
I _{T(AV)}	Mean on-state current	180° half sine wave 50Hz Double side cooled	T _C =55°C	125			2500	A
V _{DRM}	Repetitive peak off-state voltage	tp=10ms		125	800		2000	V
V _{RRM}	Repetitive peak reverse voltage				1000		1800	V
I _{DRM} I _{RRM}	Repetitive peak current	at V _{DRM} at V _{RRM}		125			200	mA
I _{TSM}	Surge on-state current	10ms half sine wave		125			29	kA
I ² t	I ² t for fusing coordination	V _R =0.6V _{RRM}					4205	10 ³ A ² s
V _{TO}	Threshold voltage			125			1.10	V
r _T	On-state slope resistance						0.13	mΩ
V _{TM}	Peak on-state voltage	I _{TM} =4000A, F=32kN	15 ≤ tq ≤ 28	25			2.20	V
			29 ≤ tq ≤ 50				2.00	V
			51 ≤ tq ≤ 75				1.80	V
dv/dt	Critical rate of rise of off-state voltage	V _{DM} =0.67V _{DRM}		125			1000	V/µs
di/dt	Critical rate of rise of on-state current (Non-repetitive)	V _{DM} = 67%V _{DRM} , Gate pulse t _r ≤ 0.5µs I _{GM} =1.5A		125			1500	A/µs
Q _{rr}	Recovery charge	I _{TM} =2000A, tp=4000µs, di/dt=-20A/µs, V _R =100V		125		750		µC
t _q	Circuit commutated turn-off time	I _{TM} =2000A, tp=4000µs, V _R =100V dv/dt=30V/µs, di/dt=-20A/µs		125	15		75	µs
I _{GT}	Gate trigger current	V _A =12V, I _A =1A		25	40		250	mA
V _{GT}	Gate trigger voltage				0.9		2.5	V
I _H	Holding current				20		1000	mA
I _L	Latching current						1000	mA
V _{GD}	Non-trigger gate voltage	V _{DM} =67%V _{DRM}		125			0.3	V
R _{th(j-c)}	Thermal resistance Junction to case	At 180° sine double side cooled Clamping force 32kN					0.012	°C/W
R _{th(c-h)}	Thermal resistance case to heatsink						0.003	
F _m	Mounting force				30		40	kN
T _{vj}	Junction temperature				-40		125	°C
T _{stg}	Stored temperature				-40		130	°C
W _t	Weight					880		g
Outline	KT60cT							

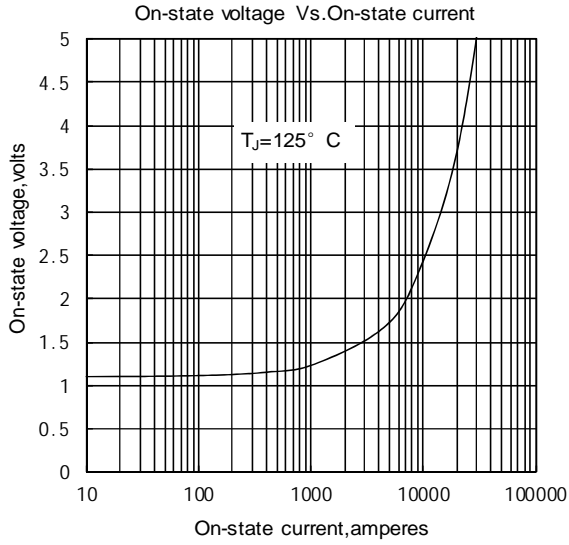

Fig.1

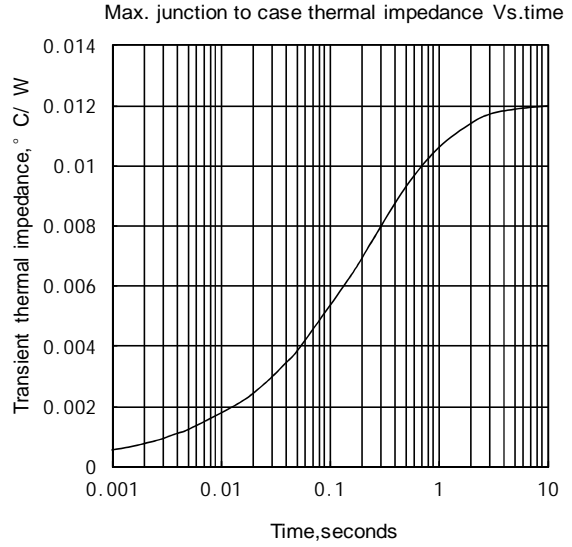

Fig.2

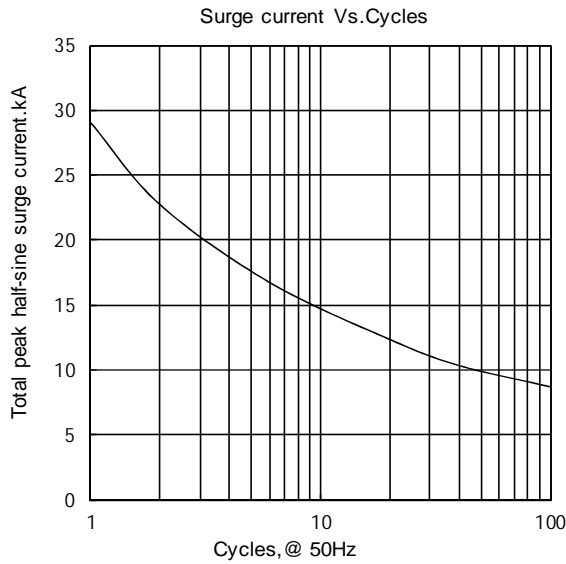

Fig.3

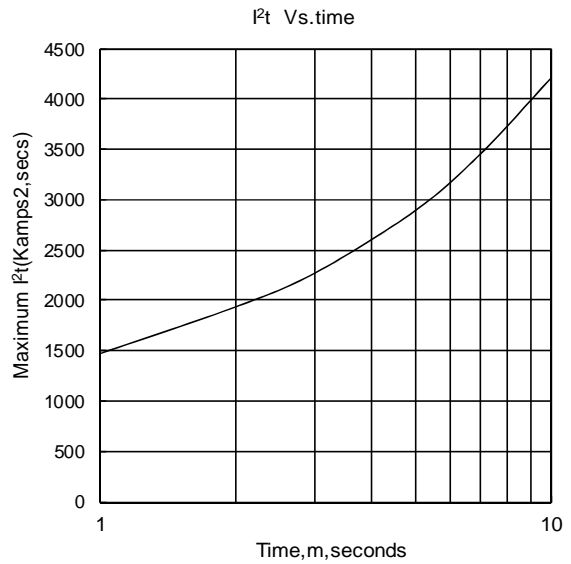

Fig.4

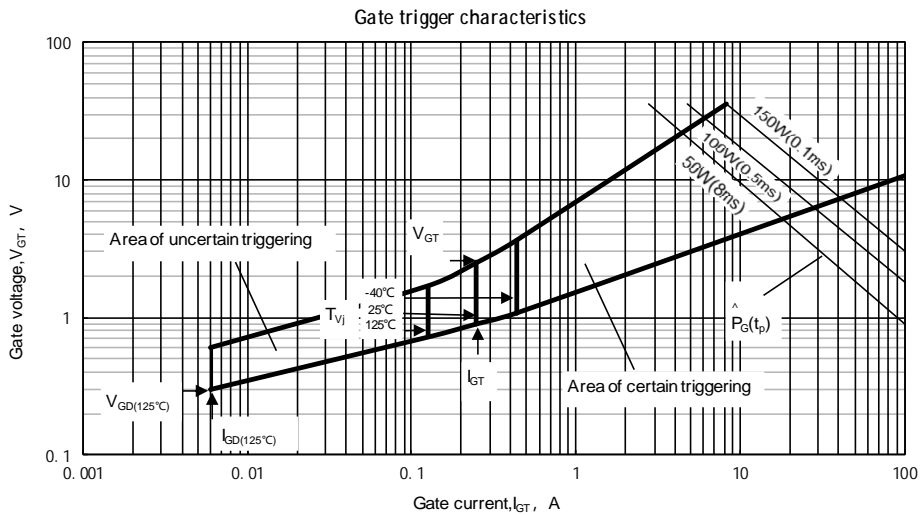
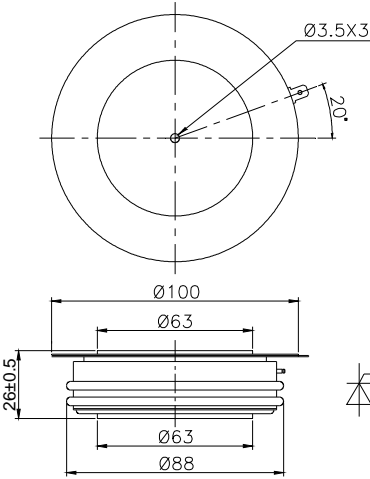

Fig.5

Outline:



TECHSEM reserves the right to change specifications without notice.