

HelenX



Collaborative Robots

A customized solution according to your laboratory

About XImaging

XImaging is an artificial intelligence company which focuses on life science, applied chemistry and microbiology area etc. XImaging dedicates to the intelligent automation products and systematic solution from food, pharmaceutical, environment, clinical diagnosis to analysis test etc. XImaging originated from AI and SciX and it also has the artistic conception that science beauty is achieving by AI. XImaging is the global leader of AI scientist which transfers the robot scientist from knowledge concept to reality.

XImaging established AI and digital R&D center, automatic product R&D center, applied product, solution and customer center as specialized and sophisticated enterprise and high-tech company of artificial intelligence area as well as the member of China Biology Facilities and Biological Standardization Committee.

XImaging has the value of simplicity, honest, altruism and open mind of innovation, concentration, win-win. XImaging devotes to establish the symbiosis and prosperity of cooperative partner system with customers. AI robot of XImaging will go into every laboratory to assist scientists to accomplish the pharmaceutical research, microbial manufacture, energy chemical, clinical diagnosis etc.

XImaging is your best cooperator in the AI era.

Our Vision

XImaging aspires to be world leading solution supplier of life science automation and intelligence. XImaging dedicates high quality technology, products and service.



High-tech Enterprise



SMEs

Customer's Trust



HelenX Laboratory Collaborative Robot

The space of laboratory is limited and experiments' activities are various. HeleX bases on the common collaborative activities from grip, transfer, placement to test.

All details, such as cover of joint or gripper, were all designed strategically. The aim is to adapt to the collaborative robot in the laboratory which covers chemistry, analysis, test and microbial research.

HelenX is customized for laboratory scenarios.

Plug and play Gripper Bank

Different kinds of gripper for consumables

The software which contains different parameters of consumables

Sample absence detection and error report

The detection of torque of gripper, sample series number , scanning code for double verification

The positioning accuracy is the same as the size of hair

Position error: 0.05mm

Security collaboration with high space usage

Internal rotation design

The work range is extended. The space can meet the requirements of a laboratory. Sensitive modes for collision detection can assure collaborative security.

High efficiency robot teaching system

It's suitable for all types of robots produced by XImaging. It can be used to view website and it supports multiple client platform. Visualization position can help site application.

The extensive scalable functions

Collaborative ecology can be established by voice interaction and vision system. It's no need to worry about the instruments drives after expand the software.

Knowing HelenX

HelenX has two types of robot, fixed collaborative robot and mobile collaborative robot. Each robot has its own work range, load and application scenario. All these robots are easy and reliable to use. It is the best choice for all kinds of experiment equipment and experiment tasks.

HelenX

The aim is to energize more imagination.

- HelenX can energize original equipment manufacturers for more product service and solutions.
- HelenX can energize end users for more optimized workflow, better productivity, experimental data and product quality.

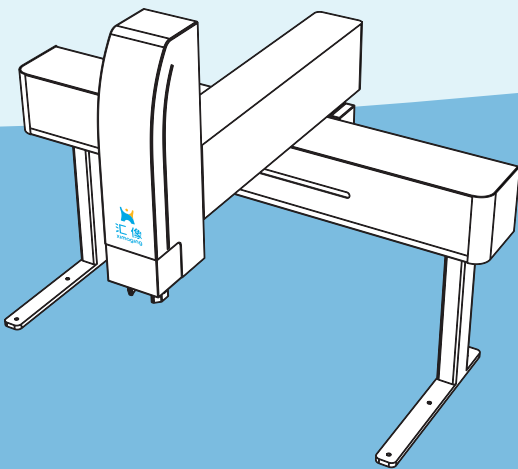

HelenX-E

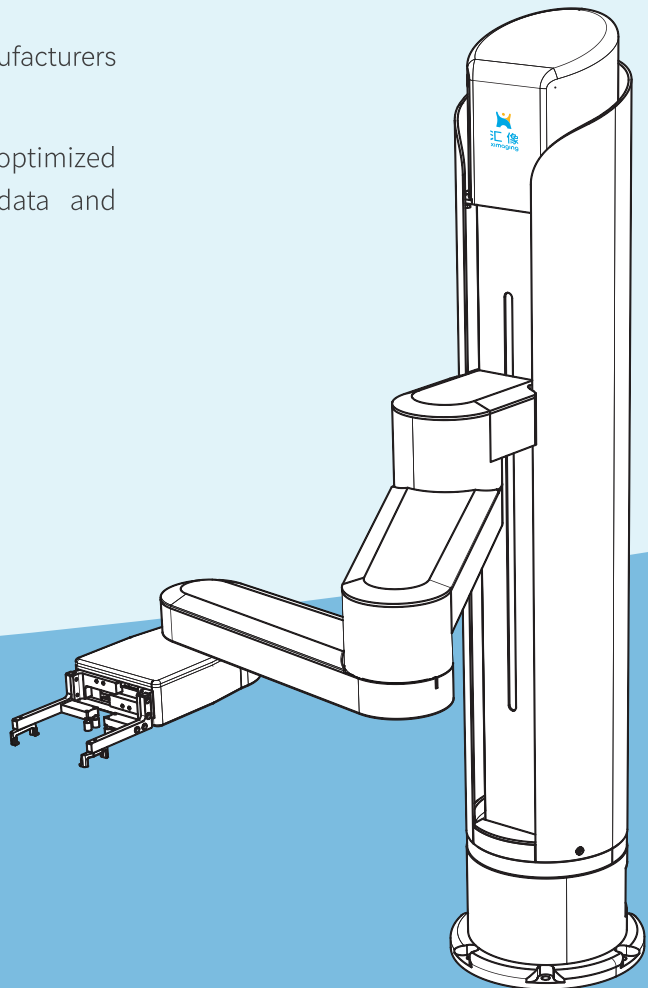

HelenX-5

Fixed Collaborative Robot (HelenX)

It's suitable for high precise collaborative and assembly application scenarios.

•))) Hi Helen, please check the operating experiment.

Hello, customer has logged in, it's operating the 5th experiment in the experiment sequence which is scheduled by Researcher Meimei Han. ((•

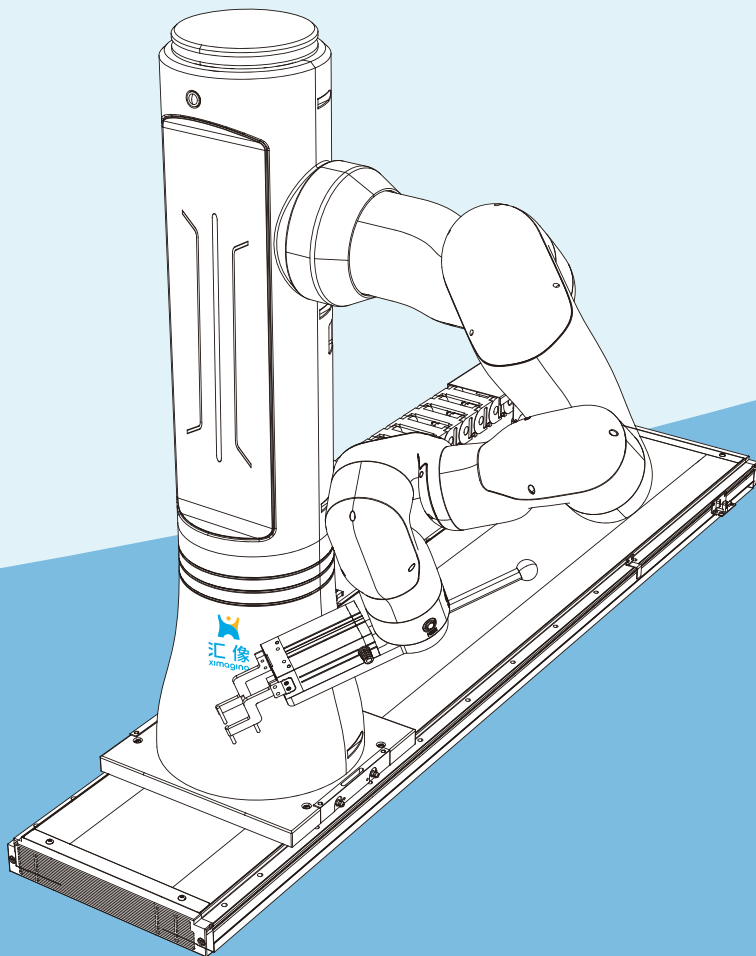

HelenX-R7

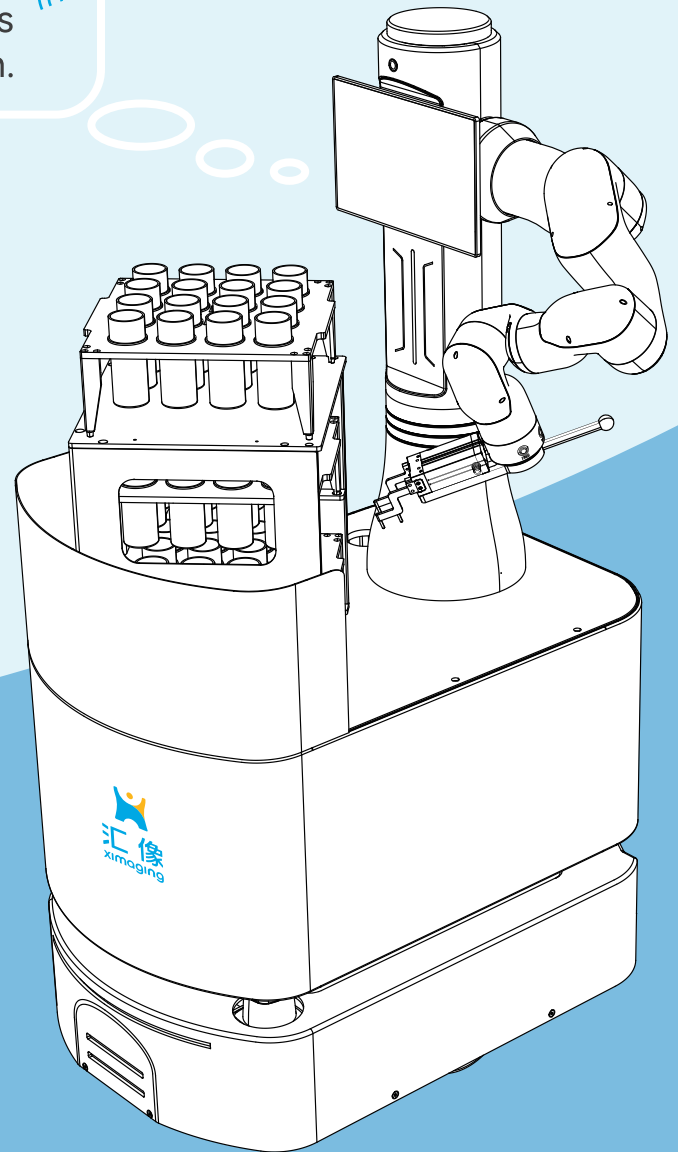

HelenX-MR7

Mobile Collaborative Robot (HelenX-R)

It's suitable for flexible deployment and high synthesis application scenarios.

HelenX-5

Fixed Collaborative Robot

HelenX-5

- HelenX-5X is a favorite fixed collaborative robot by the customers. It consists five joints with internal rotation action design. It also has extending function which can save space. The operating speed is rapid and it has flexible space trajectory. It has safety collaboration of intelligent obstacle avoidance.
- HelenX-5 has installed high performance scanner. It supports 1D or 2D barcodes for different consumables. It can easily accomplish samples traceability and absence detection.
- HelenX-5 supports voice interaction with 360°. The laboratory work becomes relax and laboratory management becomes directly.

Features

Flexible Gripper

The tool package of hardware gripper covers different kinds of sample containers and consumables. The load of gripper can reach 3kg.

Ultra-high Space Utilization

The internal joint rotation design, freely switch direction, compact or scalable work range

Sample Traceability of Whole Process

The torque detection gripper is equipped with the scanner. It supports sample information reading and sample absence detection.

Intelligent Voice Interaction

The experiment operation order will be direct and high efficient.



Recommendation Application Scenarios



The barcode information identification of target sample



The delivery of target sample consumable



Sampling with the analysis instruments

Cases



The experiment assistant to flow injection instrument

HelenX-5 will deliver the water sample which put in left side on the table to the sample plate automatically. It can accomplish injection analysis in 24 hours.



The assistant to the cell image test

HelenX-5 will put the microplate into BioTek Cytation5 orderly without any manual operation. The next microplate will be put inside after the existing test is over. It fitted with code scanning devices which can record the analysis time automatically and it can correspond to analysis date in real time.



The experiment assistant to EDX

HelenX-7 is equipped with end effector which has double function of grip and button opener. It can accomplish the automatic opening or closing cover of EDX and the target sample can be put inside automatically. This system can fulfil the input sample and output result without any manual participation.

HelenX-MR7

Mobile Collaborative Robot

HelenX-MR7

HelenX-MR7 is a high integrated robot and it is the core product for the deployment of medium or large-scale function island and construction intelligent laboratory. It has complicated units such as 7 execution joints, removable panels and voice & video interaction.

- 7 execution joints can compensate the restriction of 6-axis robot in space and the flexibility is better.
- The main part is equipped with wireless panel and the panel supports face identification. The experiment process can be viewed in real time. And it can also be detached as teaching device.
- It is fitted with voice&video interaction module and this module can improve the experiment direction from operator instead of boring operation on the touch panel between operator and equipment.
- HelenX-MR7 is navigated by laser radar and this makes it easy to go through the target positions which are located in different rooms or on different floors. It is a real high performance robot system.

Features

Ultra-high Execution Efficiency

It has 7 execution joints which is accurate and flexible to operate the experiments. It is installed dispatch management software. It is permitted by multiple devices to operate separately. It is suitable for complex application scenarios.

Sensitive Security Collaboration

Mobile platform has distance detection system. It will reduce speed or stop when it detects the pedestrian or obstacle. The robot arm has protection function of collision. It will be stopped in an emergency.

Unlimited Work Space

Laser radar free navigation system can help the robot operate across the rooms and floors.

Temperature Work Environment

The voice interaction and vision system can contribute to establishing the temperature collaboration ecology of laboratories.



Recommendation Application Scenarios



Limited Space

The mobile robot can go through a small space through laser navigation.



Cross Floors

The mobile robot can go through a small space through laser navigation.



Hard Reconstruction

It's unnecessary to reconstruct the original laboratory by using mobile robot.



Irregular Position of Equipment

The mobile robot can find the required equipment by preinstalled points.



Unattended Cleaning Area

The mobile robot can find the required equipment by preinstalled points.



Hazardous Biochemical Environment

It's unnecessary to reconstruct the original laboratory by using mobile robot.

Case

HelenX-MR6 contributes to establish the automatic laboratory for "water automatic analysis laboratory". It can accomplish the different parameters of full process automatic and intelligent test such as total phosphorous, total nitrogen, ammonia nitrogen and potassium permanganate etc.



HelenX-MR7 contributes to establish intelligent laboratory for "oil analysis intelligent laboratory". It can accomplish a series of complex test by whole process automatic test such as dissolved gas compositions, acidity, water content, dielectric strength and dielectric loss etc. It comes true that the experiment report will be exported automatically after the samples are imported.



Gripper Bank of Robot

Tools package of hardware gripper:

To support grip all kinds of experiment consumables

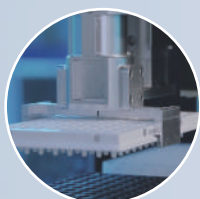

Rectangular Microplate

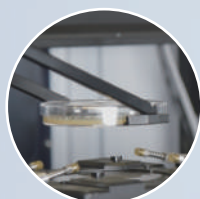

Petri Dish



EP Tube



Glass Tube



Sampling Bottle



Conical Flask



Mobile Phase Bottle

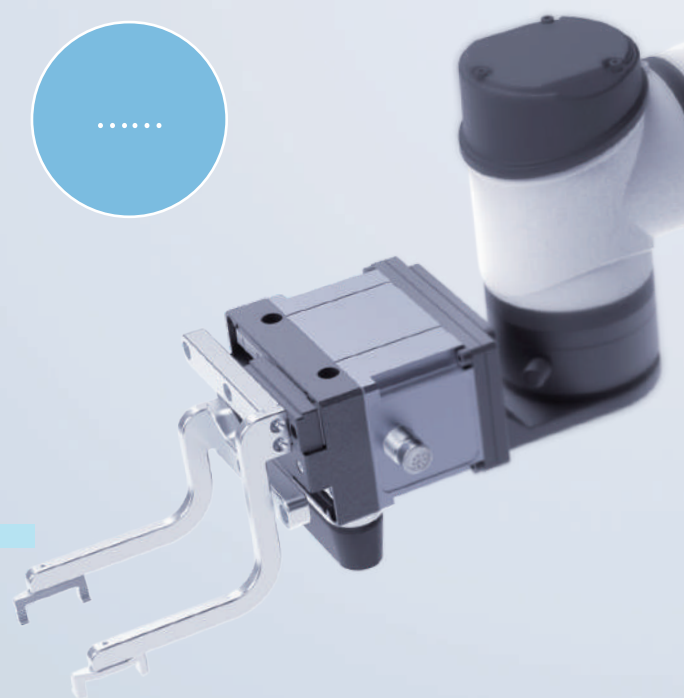

Plug and play software package:

One click setting

- The software has installed with all kind of consumables and weight parameters.
It's unnecessary to input manually every time.
- The software supports the expanding target consumables bank by the customers.
Plug and play.



Software Introduction

Teaching system and open source API of XImaging robot

The software system of robot control is developed by XImaging which supports online teaching systems and wireless teaching systems.

The teaching system is controlled by control cabinet or motion controller through communication cables or network cables. Through setting motion parameter or programming the motion path of robot, the robot can work according to the programmed processing document. The motion of robot can also be operated, such as real-time monitoring, adjustment or emergency stop.



User-friendly

The user interface of teaching is clear and intuitive. Process management and shortcut management help the robot operate effectively.

Low Speed Control

It's unnecessary to use the long cable to view website or debugging. It supports remote control by multiple customer platform.

Intelligent Application

The software accomplish 3D simulating robot motion by using 3D simulation technology. The motion process can be edited intuitively. The site application can be seen and felt by the visual points of software.

High Versatile

The teaching system is suitable for all types of XImaging robots. It is compatible to third party robots.

XImaging Cooperative Partner Program

The aim is to research the automatic solution of related instruments for customers. It can help customer improve competitive advantages and it also increase the product value.

XImaging Cooperative Partner Program will collaborate with the like-minded partners for commercial and strategic cooperation.

Why do you select XImaging for your automatic solution?

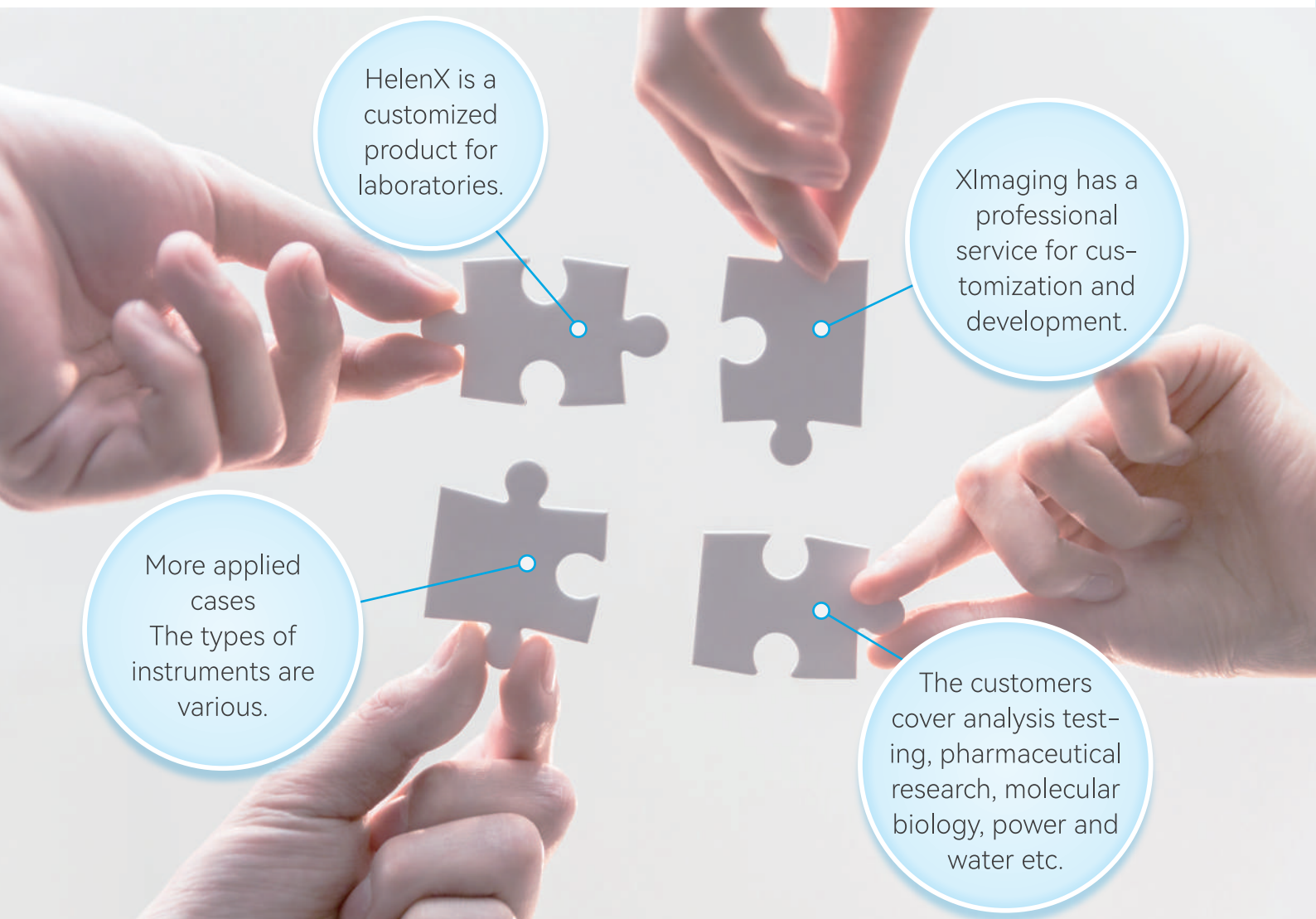

HelenX is a customized product for laboratories.

XImaging has a professional service for customization and development.

More applied cases
The types of instruments are various.

The customers cover analysis testing, pharmaceutical research, molecular biology, power and water etc.

How does XImaging cooperate with you?

01

Technical Requirement

What is the automatic solution for your customer?

02

Recommendation Solution

XImaging will give you a detailed solution according to your requirements.

03

Quotation

XImaging will send you the quotation of solution.

04

Application

XImaging can help you apply a detailed solution.

05

Operation Guarantee

XImaging will open periodic professional training sessions and issue the certificate.

06





Product Launch



XImaging will supply the automatic product continuously.



07

Continued support

XImaging will supply the continued support of automatic products such as training, application support and after-sale service.

Product		HelenX-3	HelenX-5	HelenX-6	HelenX-7
Product Photograph					
Robot	Degree of Freedom	3	5	6	7
	Maximum Robotic Arm	/	765mm(Not including gripper) 900mm(Including gripper)	886 mm	580 mm
	Range of Motion	X axis:700mm (Customizable) Y axis:300mm (Customizable) Z axis:220mm (Customizable) J4:+/-180°	J1: +/-180° Rotation J2(Z): 480mm Standard, 750mm (Customizable) J3: +/-90° Rotation J4:+/-175°Rotation J5:+/-180°Rotation	J1: +/-360° Rotation J2: +/-360° Rotation J3: +/-360° Rotation J4: +/-360° Rotation J5: +/-360° Rotation J6: +/-360° Rotation	J1: +/-180° Rotation J2: +/-360° Rotation J3: +/-125° Rotation J4: +/-130° Rotation J5: +/-360° Rotation J6: +/-120° Rotation J7: +/-360° Rotation
	Repetitiveness Positioning Accuracy	+/-0.05mm	+/-0.05mm	+/-0.02mm	+/-0.05mm
	Load	1kg	3kg	5kg	1kg
	Weight	20kg	28kg	24kg	20kg
	Speed	1000mm/s	1000mm/s	2000mm/s	1500mm/s
	Average Power	100w	150w	200w	150w
	Protection Level	/	/	IP54	/
	End Effector	Force Control Gripper: Dual Mode Control Distance /Torque Clamping Force 0-20N adjustable	Force Control Gripper: Dual Mode Control Distance /Torque Clamping Force 0-50N adjustable	Force Control Gripper: Dual Mode Control Distance /Torque Clamping Force 0-140N adjustable	Force Control Gripper: Dual Mode Control Distance /Torque Clamping Force 0-20N adjustable
	Vision System	Optional	Optional	Optional	Optional
Voice Interaction	/	Intelligent Voice Interaction Far-field Microphone Array Circular 6 Microphones Array Sound Localization Robot Voice Call / Navigation	/	Intelligent Voice Interaction Far-field Microphone Array Circular 6 Microphones Array Sound Localization Robot Voice Call / Navigation	
Working Environment	Power Supply	100-240VAC,50-60Hz			
	Working Temperature (°C)	0-50°C			
	Humidity (% r.h.)	Relative Humidity (non-condensing)			
Communication and Interface	Communication	Ethernet, TCP/IP, WIFI			
	Interface and Openness	SDK, API			
	Operation Interface	Graphical Web-based Controller			

Product		HelenX-R5	HelenX-R6	HelenX-R7
Product Photograph				
Robot	Degree of Freedom	5	6	7
	Maximum Robotic Arm	765mm(Not including gripper) 900mm(Including gripper)	886 mm	580 mm
	Range of Motion	J1: +/-180° Rotation J2(Z): 480mm Standard, 750mm (Customizable) J3: +/-90° Rotation J4: +/-175°Rotation J5: +/-180° Rotation	J1: +/-360° Rotation J2: +/-360° Rotation J3: +/-360° Rotation J4: +/-360°Rotation J5: +/-360° Rotation J6: +/-360°Rotation	J1: +/-180° Rotation J2: +/-360° Rotation J3: +/-125° Rotation J4: +/-130°Rotation J5: +/-360° Rotation J6: +/-120°Rotation J7: +/-360° Rotation
	Repetitiveness Positioning Accuracy	+/-0.05mm	+/-0.02mm	+/-0.05mm
	Load	3kg	5kg	1kg
	Weight	28kg	24kg	20kg
	Speed	1000mm/s	2000mm/s	1500mm/s
	Average Power	150w	200w	150w
	Protection Level	/	IP54	/
	End Effector	Force Control Gripper: Dual Mode Control Distance /Torque Clamping Force 0-50N adjustable	Force Control Gripper: Dual Mode Control Distance /Torque Clamping Force 0-140N adjustable	Force Control Gripper: Dual Mode Control Distance /Torque Clamping Force 0-20N adjustable
Vision System	Optional	Optional	Optional	
Voice Interaction	Intelligent Voice Interaction Far-field Microphone Array Circular 6 Microphones Array Sound Localization Robot Voice Call / Navigation	/	Intelligent Voice Interaction Far-field Microphone Array Circular 6 Microphones Array Sound Localization Robot Voice Call / Navigation	
Working Environment	Power Supply	100-240VAC,50-60Hz		
	Working Temperature (°C)	0-50°C		
	Humidity (% r.h.)	Relative Humidity (non-condensing)		
Communication and Interface	Communication	Ethernet, TCP/IP, WIFI		
	Interface and Openness	SDK, API		
	Operation Interface	Graphical Web-based Controller		
Linear Guide Rail Module	Motion Range	1m/1.5m/2m(Customizable)		
	Repetitiveness Positioning Accuracy	+/-0.05mm		
	Max Movement Speed	1200mm/s		

Product		HelenX-MR5	HelenX-MR6	HelenX-MR7
Product Photograph				
Robot	Degree of Freedom	5	6	7
	Maximum Robotic Arm	765mm(Not including gripper) 900mm(Including gripper)	625mm	580 mm
	Range of Motion	J1: +/-180° Rotation J2(Z): 480mm Standard, 750mm (Customizable) J3: +/-90° Rotation J4: +/-175°Rotation J5: +/-180° Rotation	J1: +/-360° Rotation J2: +/-360° Rotation J3: +/-360° Rotation J4: +/-360°Rotation J5: +/-360° Rotation J6: +/-360°Rotation	J1: +/-180° Rotation J2: +/-360° Rotation J3: +/-125° Rotation J4: +/-130°Rotation J5: +/-360° Rotation J6: +/-120°Rotation J7: +/-360° Rotation
	Repetitiveness Positioning Accuracy	+K6/-0.05mm	+/-0.05mm	+/-0.05mm
	Load	3kg	3kg	1kg
	Weight	28kg	16kg	20kg
	Speed	1000mm/s	1500mm/s	1500mm/s
	Average Power	150w	150w	150w
	Protection Level	/	IP54	/
	End Effector	Force Control Gripper: Dual Mode Control Distance /Torque Clamping Force 0-50N adjustable	Force Control Gripper: Dual Mode Control Distance /Torque Clamping Force 0-140N adjustable	Force Control Gripper: Dual Mode Control Distance /Torque Clamping Force 0-20N adjustable
AGV undercarriage	Navigation Mode	Double Laser Radar	Double Laser Radar	Double Laser Radar
	Drive Form	Double-wheel differential	Double-wheel differential	Double-wheel differential
	Workload	150kg	150kg	150kg
	Battery Capacity	48v/35Ah	48v/35Ah	48v/35Ah
	Charging Mode	Auto/Battery Swapping/Manual	Auto/Battery Swapping/Manual	Auto/Battery Swapping/Manual
	Endurance	10h	10h	10h
Vision System	Optional	Wrist Camera Intelligent Positioning Identification 3D Structural Optical Depth Camera Max 1280*720 Binocular Depth resolution Depth Vision 85.2x58	Optional	
Voice Interaction	Intelligent Voice Interaction Far-field Microphone Array Circular 6 Microphones Array Sound Localization Robot Voice Call / Navigation	Intelligent Voice Interaction Far-field Microphone Array Circular 6 Microphones Array Sound Localization Robot Voice Call / Navigation	Intelligent Voice Interaction Far-field Microphone Array Circular 6 Microphones Array Sound Localization Robot Voice Call / Navigation	
Synthesis Positioning Accuracy	+/-0.5mm	+/-0.5mm	+/-0.5mm	
Working Environment	Power Supply	100-240VAC,50-60Hz		
	Working Temperature (°C)	0-50°C		
	Humidity (% r.h.)	Relative Humidity (non-condensing)		
Communication and Interface	Communication	Ethernet, TCP/IP, WIFI		
	Interface and Openness	SDK, API		
	Operation Interface	Graphical Web-based Controller		

Installation Flange Diagram and Working Area

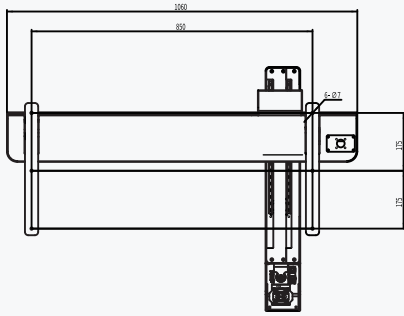

Installation Flange Diagram

HelenX-3

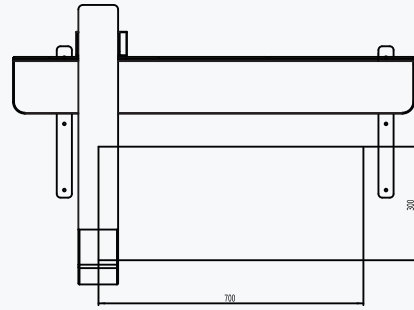

Working Area Diagram

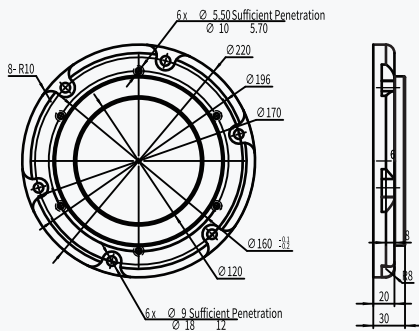

Installation Flange Diagram

HelenX-5

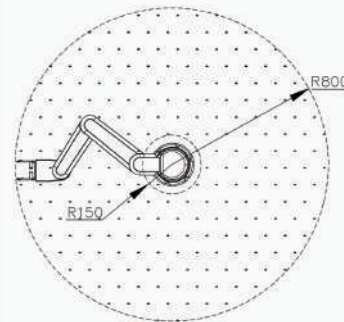

Working Area Diagram

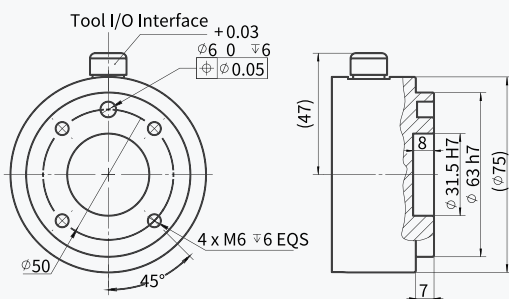

Installation Flange Diagram

HelenX-6

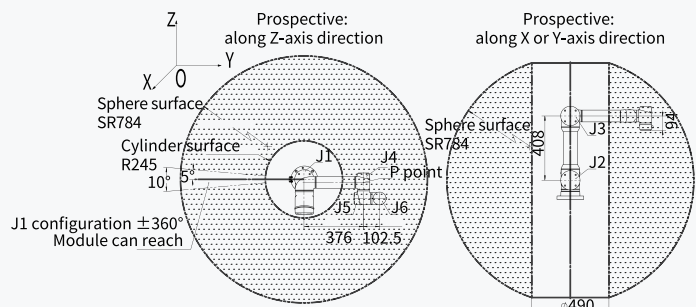

Working Area Diagram

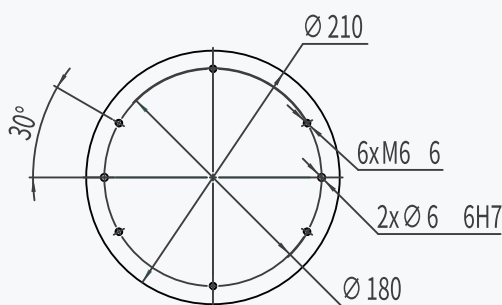

Installation Flange Diagram

HelenX-7

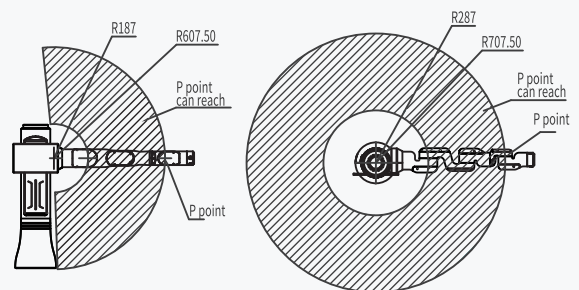

Working Area Diagram

XImaging iMagicOS

The intelligent automatic control platform, which was developed by XImaging, has intelligent operation system, distributed intelligent data center and AI intelligent computing platform. iMagicOS is integrated by central control unit and friendly Human-Computer interaction interface. It has high efficient functions such as high quality management, dispatch, monitoring, tracking and drive etc.

It can accomplish the automation control of whole laboratory from each single function island to multiple function islands. It also can be integrated the internal data from experiment data to environment data. It is suitable for high complicated experiment process management. It is widely used in different automatic laboratory scenarios of pharmaceutical research, biological pharmaceutical and testing etc.

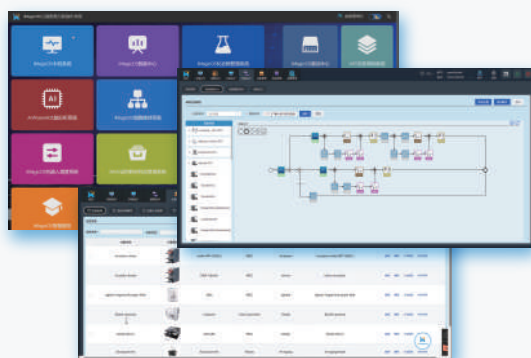

Drag-and-drop program, easy to learn

It covers the drivers of over 200 instruments

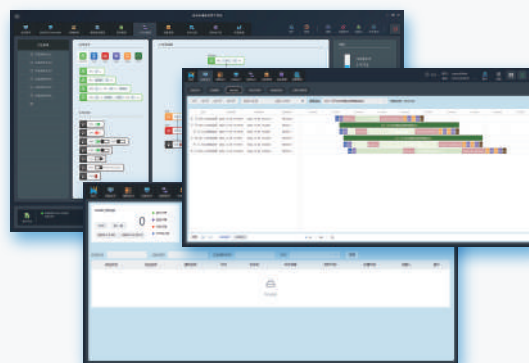

It supports multiple program operation and optimizing process.

It supports the connection of LIMS. Data interaction.



It supports the remote control by multiple platform of customer.

The app of mobile phone will be synchronized to the computer data.

It supports real-time monitoring of the equipment.

Ximaging AI Robot Scientist

The foundation of AI Robot Scientist is HelenX Robot and iMagicOS. It is the core platform for the accomplishment of experiment automatic process and intelligent laboratory. Ximaging AI Robot Scientist is compatible with third parties' equipment. The aim is to release those basic scientific researchers from boring and trivial tasks and the researchers have more time to focus on scientific research to accelerate the depth of innovation.

Ximaging is the leader of AI robot scientist and Ximaging is also one of the key company which applied the robot scientist from knowledge concept to the reality in the world. There are several hundreds applications to put into use in different areas.



HelenX-1 AI Robot Scientist System

The system will be acted as your experiment operator which can standardize to operate the experiment process. It supports the experiment process within 5 pieces of equipment. The system will be equipped with 3-axis, 5-axis or 7-axis robot according to the complicated requirement of experiment.

- OEM constructs automatic instruments
- Small intelligent automatic experiment function island
- Small intelligent automatic analysis testing platform



HelenX-2 AI Robot Scientist System

The system will be acted as your experiments' housekeeper. It can standardized execute your experiment process but also can accomplish the automation of laboratory operation process and the intelligence of laboratory data access. It can support the experimental process of hundreds of equipment. It is the core platform to build intelligent laboratory.

- Medium or large intelligent automatic experiment function island
- Intelligent combined multiple islands linkage system
- Intelligent automatic experiment assembly line
- Full process super intelligent laboratory



Intelligent Science, Selecting XImaging

Headquarter:

XImaging Intelligence Technology(Shanghai) Co.,Ltd.
Add:2nd floor,Block A,No.58 Tanzhu Road,Minhang District,Shanghai,China

Plant:

(Suzhou) XImaging Science and Technology Development Co.,Ltd
Add:1799 Shexing Road,Wujiang district,Suzhou city,China

Sales: marketsh@x-imaging.com,+86 13817386487



x-imaging.com/en xscix.com