

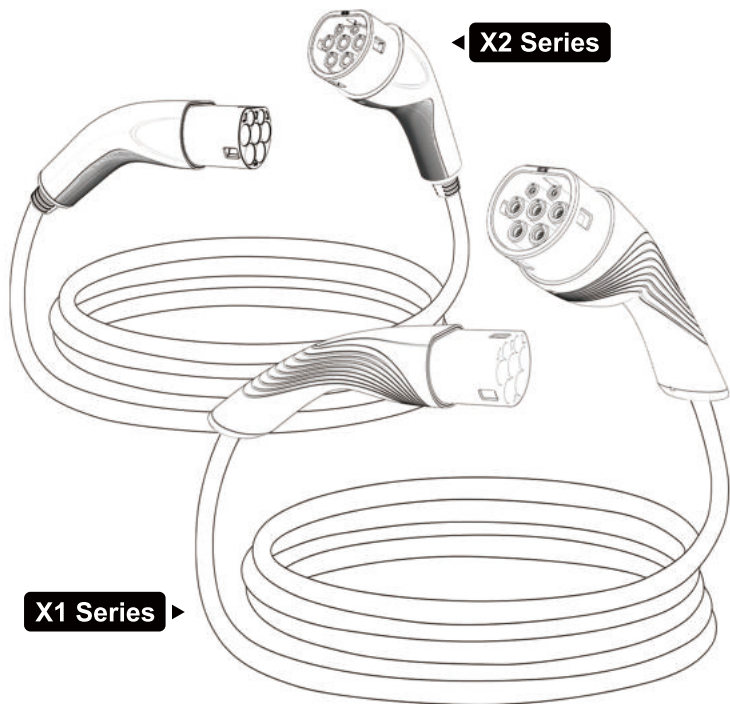

EV Charging Cable User Manual



- Type:**
- | | |
|--|---|
| <input type="checkbox"/> 1 phase 16A 3.5KW | <input type="checkbox"/> 3 phase 16A 11KW |
| <input type="checkbox"/> 1 phase 32A 7KW | <input type="checkbox"/> 3 phase 32A 22KW |

SYMBOL MEANING

Symbol	Meaning
 A black rectangular bar is positioned below the symbol.	<p>"Non-recyclable" mark: located on the product, instruction manual or package, indicating that electrical and electronic equipment and its accessories should be treated separately from ordinary household waste. When scrapped, it should be treated as industrial waste, otherwise it may cause accidents.</p>
	<p>Warning sign: indicates danger. Pay attention to the personal injury that may be caused by operation procedure or incorrect operation. Actions after the "warning" mark can only be performed when the conditions indicated by the condition are fully understood and satisfied.</p>

The company is committed to the continuous improvement and update of the product, product hardware and software will continue to upgrade, the information provided is subject to change without prior notice.

PRODUCT OVERVIEW

X1 Series ▶

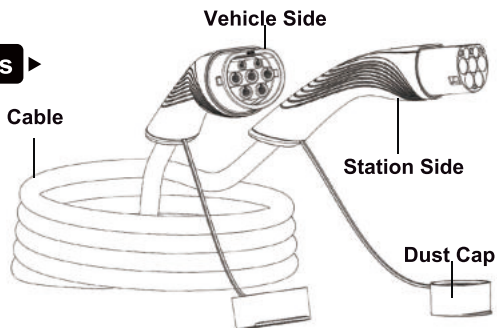

X2 Series ▶

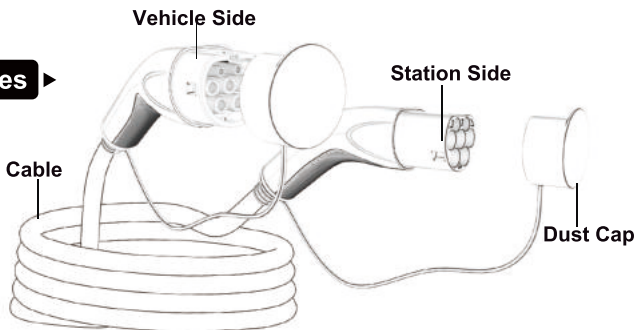

These EV charging cable, by standard IEC/EN 62196 type 2 to type 2, are intended to be used in EV conductive charging systems and for circuits specified in IEC 61851-1. It is to be used in an ambient temperature of between -35°C and $+50^{\circ}\text{C}$ by simply plugging usage.

TECHNICAL DATA

Model No.	GO-EC032T & GO-EC132T	GO-EC016T & GO-EC116T	GO-EC032S & GO-EC132S	GO-EC016S & GO-EC116S
Rated current	32A	16A	32A	16A
Rated voltage	400V (three-phase)	400V (three-phase)	250V (single-phase)	250V (single-phase)
Cables	5G6+1x0.75	5G2.5+1x0.75	3G6+1x0.75	3G2.5+1x0.75
Coding resistor	220Ω 0.5W	680Ω 0.5W	220Ω 0.5W	680Ω 0.5W
Rated power	22kW	11kW	7kW	3.5kW

*Charging power subject to power design of EVSE device and vehicle

Electrical performance

Protection rank	IP65
Fire retardant level	UL94-V0
Insulation resistance	> 1000MΩ(DC 500V/60S)
Terminal temperature rise	< 50K
Withstand voltage	2000V
Contact resistance	0.5m ohm Max
Coupled insertion force	> 45N < 100N
Operating temperature	-35C to 50C
Mechanical life	No load plug in / pull out > 10000 times
Impact of external forces	Qualify 1m drop or 2 Ton vehicle run over

Interlock function and circuit

- ▶ The connectors is not suitable for making and breaking an electrical circuit under load.
- ▶ It shall be equipped with interlock (retaining device) after the completing assembly
- ▶ The interlock function shall be performed by the proper functioning of the latching device and will be checked according to the standard. The interlocking means shall offer a feedback to show that mechanism is in correct engagement.
- ▶ Proximity detection and current coding shall be realized by implementation of IEC 61851-1 Annex B.5
- ▶ "System for simultaneous proximity detection and current coding for vehicle connectors and plugs".
- ▶ The pilot function shall be realized by implementation of IEC 61851-1 Annex A,"
- ▶ Pilot function through a control pilot circuit using PWM modulation and a control pilot wire".

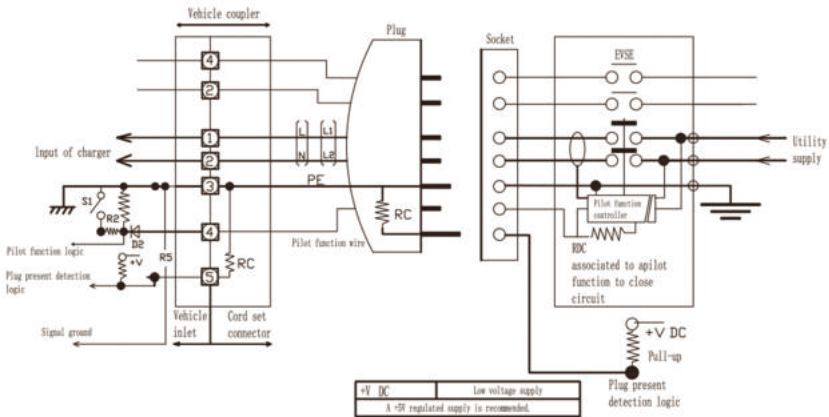

Figure 1:

Example for the simultaneous proximity detection and current coding function



WARNINGS

- Please do not use any extension cord or adapter
- Please do not use the charging cable if it is defective (racked frayed, broken or damaged in any means).
- Please do not plug the charging cable into a defective, loose or worn power outlet.
- Please do not insert the plug if any electrical outlet is wet or dirty.
- Please do not dismantle the protective cap. It protects the charging connector from moisture and dirt.
- After every use put the protective caps back on
- Please do not try to disassemble the shell or any part of the cable.
- It will cause damages to the item and thus cause serious results when charging.
- Accordingly to your charging device and vehicle, the power rate is backwards compliant, yet couldn't handle higher power rate, which will cause temperature rise and charging shutdown.

HANDLING

Please handle the charging cable with care. Do not pull, twist, tangle drag, drop or step on it.

USAGE

Please read your vehicle's charging instructions before using the charging cable. Check the outlet on charging station and the inlet on vehicle before inserting the plugs.

The plug must be fully inserted into the outlet and inlet.

Failure to do so will prevent the charging station from start charging

1. Insert the cable plugs into the vehicle inlet and charging station outlet
2. Make sure both plugs are properly connected, charging can start.
3. Do not disconnect the charging cable while the vehicle is charging
4. After charging is completed unplug the charging cable from the vehicle, then from the charging station

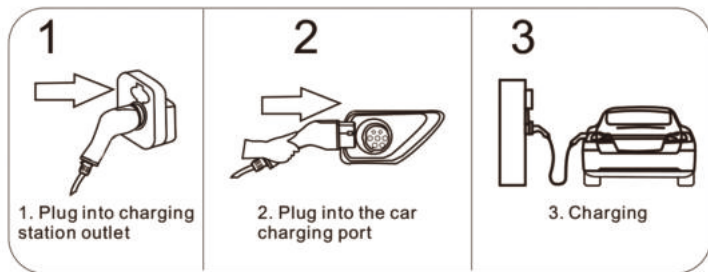

CARE

Clean the charging cable only when it is disconnected by using a damp cloth. Please do not use water or chemicals when cleaning the cable

E-Mail:

Contact@gocean.com

Website:

<https://www.gocean.com/>

Manufacturer:

Shenzhen green ocean new energy Technology Co.,LTD

Address:

4/F,Building 7,No.28,Baotian 3rd Road, Chentian Community
Xixiang Street,Baoan District, Shenzhen