

**PASON**<sup>®</sup>

普尔思（福建）泵业有限公司  
PREEMINENCE PUMP CO., LTD.

 Address:  
No.1.Pulin Road,Lintun Industrial Zone,Songxi,Fujian,China

 Phone:  
0086-591-8826 3842 / 8826 3843 / 8826 3845

 Email:  
sales@pasonpump.com

 Website:  
www.pasonpump.com

**PASON**<sup>®</sup> PUMP  
Exploring the Power of fluid dynamics



国家高新技术企业

ISO 9001-2015



www.pasonpump.com



PREEMINENCE PUMP CO., LTD

# PASON PUMP

## Brief Introduction

Established in **2010**, Preeminence Pump is a comprehensive Pump Factory who Specialized in Pump Design, Development, Manufacture and Marketing. The Mainly Products of Preeminence Pump include End Suction Pump ( **DIN24255** and **ISO2858** Standard), Self Priming Sewage Pump, Diesel Engine Pump and etc. After more than **15** Years development, Preeminence Pump was awarded to be National High-Tech Enterprise, Little Tech. Giant enterprise and Etc.

At present, Preeminence Pump already reach **30,000** PCS Yearly production Capacity and offer pumps to clients from more than 80's different countries



国家高新技术企业

ISO9001-2015



## Contents

<b>PA Series</b> DIN24255/EN733 Std End Suction Back Pull-Out Centrifugal Pump	<b>01-08</b>
<b>PAC/PISC Series</b> Close- Coupled Centrifugal Pump (DIN24255/ESBN 733 Std AND ISO2858/5199 Std)	<b>09-12</b>
<b>PISO Series</b> ISO2858/5199 Std End Suction Back Pull-Out Centrifugal Pump	<b>13-20</b>
<b>PCC Series</b> Chemical Process Pump (ISO5199/2858, EN 25199/22858 Std)	<b>21-28</b>
<b>PPS Series</b> Pulp Pump	<b>29-36</b>
<b>PT Series</b> Self Priming Trash Pump	<b>37-42</b>
<b>PPW Series</b> Non-Clogging Process Pump	<b>43-48</b>
<b>PZA Series</b> Petrol-Chemical Pump	<b>49-54</b>
<b>D Series</b> Horizontal Multi-stage Centrifugal Pump	<b>55-63</b>

# PA Series

## DIN24255/EN733 Std End Suction Back Pull-Out Centrifugal Pump



### Key Benefits

PASON Pumps are all designed, engineered and manufactured at our facility. In-house casting of all our metals means we can provide competitive pricing and short lead times. We are dedicated to delivering the highest levels of customer satisfaction at all times by offering...

- a dedicated & professional after-sales support team
- a large inventory of components, parts & assemblies at our stock
- a diverse range of configurations to suit various applications
- ISO 9001 certification quality management control system
- a reputation for rugged and reliable pumps that are easily maintained
- experienced drafting & fabrication team for complete customised solutions

### Design



Design	Performance and dimension as per DIN24255 / BSEN 733
Structure	Horizontal ,End suction, Single suction,Volute casing
DN(mm)	Suction size: 50~300, Discharge size: 32~250
Flange	DIN 2501,PN16

### Material

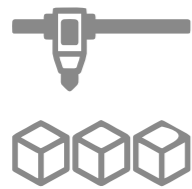

Pump parts	Material
Casing / Impeller	Cast iron, Stainless steel
Shaft	Stainless steel
Shaft seal	Mechanical Seal, Gland Packing,Dynamic seal
Bearing lubrication	Grease Life ,Grease, Oil
Bearing Brand	NTN

### Operating Data

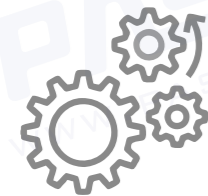

Speed	Up to 3600rpm
Flow Rate(Q)	Up to 1100m³/h-1450rpm 1600m³/h-1750rpm
Head(H)	Up to 160m
Pressure	Up to PN16
Liquid Temperature	Up to 105°C

### Design & Features



The PA series Back-pull-out Pump is a horizontal end suction, vertical top discharge, single stage, foot mounted centrifugal pump ~ Conforming to DIN24255/BESN733 standard.

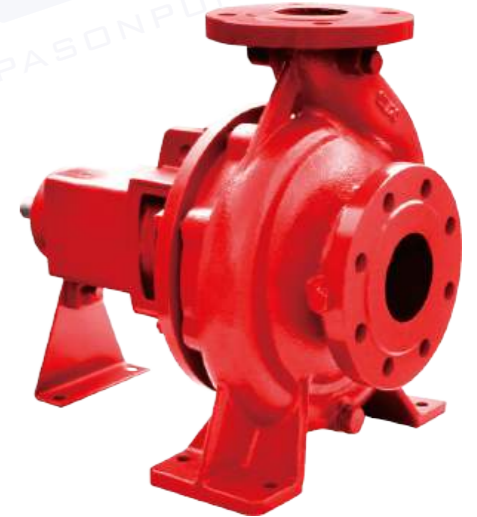

The PA series Back-pull-out Pump is a true back-pull-out (BPO) meaning, when configured with a spacer coupling, the electric/diesel motor remains undisturbed in position, while the back plate and rotating assembly can be removed for servicing.

This effective design reduces equipment down time and allows an identical assembly to be reinstalled with minimal service interruption.

DIN24255/ BSEN 733 standard ensures dimensional interchangeability with other pumps conforming to this recognised international standard.

This means that PASON Pumps can provide a pump in superior material to directly interchange with other manufacturer's equipment.(No pipe work or motor changes required)



### Applications

Water Supply Systems

Pressure Boosting

Heating Systems  
Irrigation  
Agriculture

Fire Fighting Systems

General Transport  
for Industrial  
Processes

Cooling Plants  
for Industrial  
Processing and  
Air-Conditioning  
units

**PA Series** DIN24255/EN733 Std End Suction Back Pull-Out Centrifugal Pump

**Description**

**Flange connection:**

Standard DIN 2533 PN16 / 2532 PN10  
Flanges to ANSI 150, JIS10K possible

**Maximum authorised pressure levels:**

Temperature -10°C ≤ t ≤ 105°C

Material Cast iron, Stainless steel

1) 16 bar

All others 10 bar

1) Pump model : 40/32G, 50/32G, 65/32G, 80/32G, 100/32G  
Reminder : maximum authorised casing pressure = fluid pressure at suction end + pressure at discharge end with zero flow.

**Note :** technical recommendations and safety precautions must be followed. (Refer to the commissioning instructions.)

**Flange positioning :** Axial suction flange, upwards radial discharge flange.

**Casing seal :** Standard models are sealed using fibre

**Motor power :** As standard, PA pumps are equipped with IM B3 electric motors.

To determine the drive power, we recommend the following safety margins:

Up to 4 kW : +25%  
from 4 to 7.5 kW : +20%  
above 7.5 kW : +15%

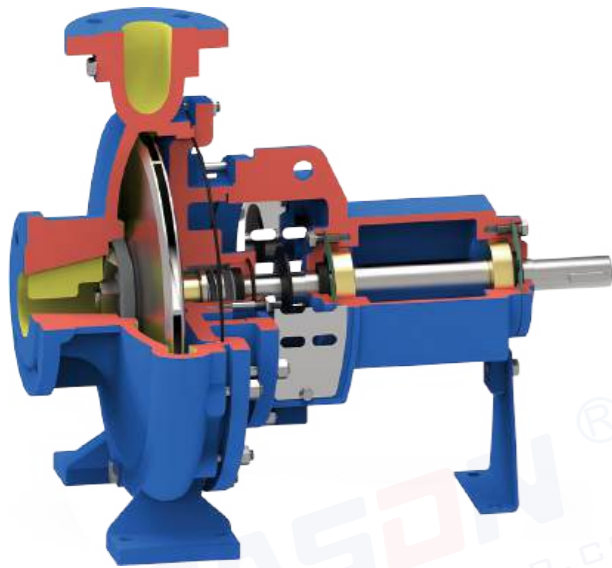

**Model Designation(Examples): PA 50-32G**

PA

Pump Series

50

Discharge(mm)

32

Impeller Nominal Diameter(cm)

G

Special Code G: Bigger shaft

**Design Specification**

**Casing:**

Open on drive side to enable the mechanical assembly to be dismantled from behind. Mounting feet under the volute casing. Axial suction, radial discharge upwards. Flanges manufactured to standard NFE 29201 (DIN 2533). PN.16. Cast iron or Stainless Steel SUS304/316 as standard. Duplex Stainless Steel 2205 or 2507 can require.

**Casing cover**

Mounted between the casing and the bearing housing and equipped with housing to receive the mechanical or gland packing shaft seal.

**Bearings**

Monobloc, oversized (to standard ISO 5199) and supported by a support foot. Grease-lubricated deep-groove ball bearings guide the motor shaft. A centrifugal deflector prevents the leaking of liquid.

**Shaft**

oversized (to standard ISO 5199) for longer me-chanical-seal service life. Shaft sleeve.

**Impeller**

Cast iron or Stainless Steel SUS304 as standard. High-efficiency closed radial impeller with back seal and balance holes. Adapted trimmed on request to comply with the Q/H required for the application.

**Shaft seal**

Single standardised mechanical seal adapted to the liquid being pumped. No servicing required during operation. stuffing box possible on request.

**Coupling**

Standard, semi-elastic coupling. Can be fitted with a spacer coupling on request.

**Sectional Drawing -3 Shaft Seal**

**Single mechanical seal type**

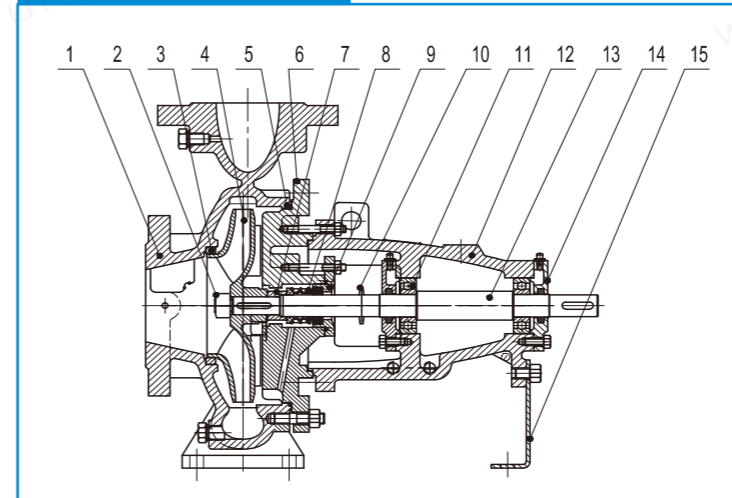

**Pump with Single mechanical seal**

S/N	Part Name
1	Pump Casing
2	Impeller Nut
3	Wear Ring
4	Impeller
5	O-Ring
6	Casing Cover
7	Shaft spacer
8	Mechanical Seal
9	Seal Gland
10	Slinger
11	Bearing
12	Bearing Housing
13	Shaft
14	Bearing Cover
15	Support Foot

**Gland packing type**

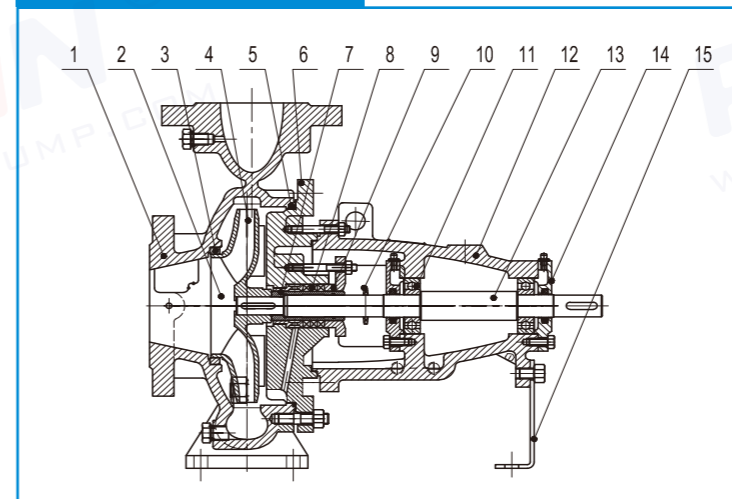

**Pump with Gland Packing**

S/N	Part Name
1	Pump Casing
2	Impeller Nut
3	Wear Ring
4	Impeller
5	O-Ring
6	Casing Cover
7	Shaft Sleeve
8	Gland Packing
9	Packing Gland
10	Slinger
11	Bearing
12	Bearing Housing
13	Shaft
14	Bearing Cover
15	Support Foot

**Dynamic seal type**

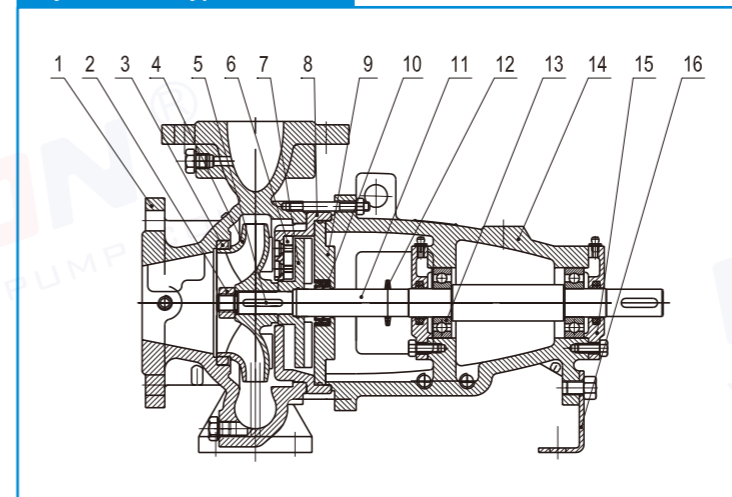

**Pump with Dynamic Seal**

S/N	Part Name
1	Pump Casing
2	Impeller Nut
3	Wear Ring
4	Impeller
5	Impeller Key
6	casing cover block
7	Vice impeller
8	Casing Cover
9	seal block plate
10	Seal Ring
11	Shaft
12	Slinger
13	Bearing
14	Bearing Housing
15	Bearing Cover
16	Support Foot

PA Series DIN24255/EN733 Std End Suction Back Pull-Out Centrifugal Pump

Intalling Dimension

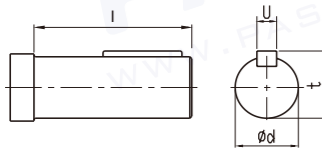

Drive Shaft Dimensions

Bearing housing	ød	l	u	t
25/25A	24	50	8	27
35	32	80	10	35
45	42	110	12	45
55	48	110	14	51

Key dimensions are nominal.

Standard Flange Connecting Dimension( ISO 2084,PN16),Option ANSI 150, JIS10K

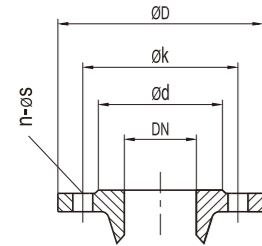

DN	ød	øk	ØD	n	øS
32	73	100	140	4	18
40	83	110	150	4	18
50	98	125	165	4	18
65	118	145	185	4	18
80	133	160	200	8	18
100	153	180	220	8	18
125	183	210	250	8	18
150	209	240	285	8	22
200	264	295	340	12	22
250	320	355	405	12	26
300	375	410	460	12	26

Service Connections

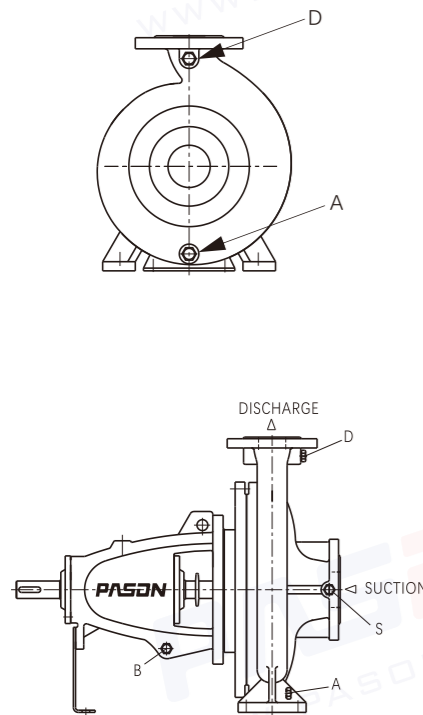

Pump Model	A	B	D	S
	Casing Drain	Housing Drain	Gauge Drain	Gauge Drain
32-13	1/4	1/4	1/4	1/4
32-16	1/4	1/4	1/4	1/4
32-20	1/4	1/4	1/4	1/4
32-26	1/4	1/4	1/4	1/4
40-13	1/4	1/4	1/4	1/4
40-16	1/4	1/4	1/4	1/4
40-20	1/4	1/4	1/4	1/4
40-26	1/4	1/4	1/4	1/4
40-32	1/4	1/4	1/4	1/4
40-32G	1/4	1/4	1/4	1/4
50-13	1/4	1/4	1/4	1/4
50-16	1/4	1/4	1/4	1/4
50-20	1/4	1/4	1/4	1/4
50-26	1/4	1/4	1/4	1/4
50-26G	1/4	1/4	1/4	1/4
50-32	1/4	1/4	1/4	1/4
50-32G	1/4	1/4	1/4	1/4
65-13	1/4	1/4	1/4	1/4
65-16	1/4	1/4	1/4	1/4
65-20	1/4	1/4	1/4	1/4
65-20G	1/4	1/4	1/4	1/4
65-26	1/4	1/4	1/4	1/4
65-32	1/4	1/4	1/4	1/4
65-32G	1/4	1/4	1/4	1/4
80-16	1/4	1/4	1/4	1/4

Pump Model	A	B	D	S
	Casing Drain	Housing Drain	Gauge Drain	Gauge Drain
80-20	1/4	1/4	1/4	1/4
80-26	1/4	1/4	1/4	1/4
80-32	1/4	1/4	1/4	1/4
80-32G	1/4	1/4	1/4	1/4
80-40	1/4	1/4	1/4	1/4
100-16	3/8	1/4	1/4	1/4
100-20	3/8	1/4	1/4	1/4
100-26	3/8	1/4	1/4	1/4
100-26G	3/8	1/4	1/4	1/4
100-32	3/8	1/4	1/4	1/4
100-32G	3/8	1/4	1/4	1/4
100-40	3/8	1/4	1/4	1/4
125-20	3/8	1/4	1/4	1/4
125-26	3/8	1/4	1/4	1/4
125-32	3/8	1/4	1/4	1/4
125-40	3/8	1/4	1/4	1/4
150-20	3/8	1/4	1/4	1/4
150-26	3/8	1/4	1/4	1/4
150-32	3/8	1/4	1/4	1/4
150-40	3/8	1/4	1/4	1/4
200-26	3/8	1/4	1/4	1/4
200-32	3/8	1/4	1/4	1/4
200-40	3/8	1/4	1/4	1/4
250-32	3/8	1/4	1/4	1/4
250-40	3/8	1/4	1/4	1/4

Dimensions-Bare Shaft Pump

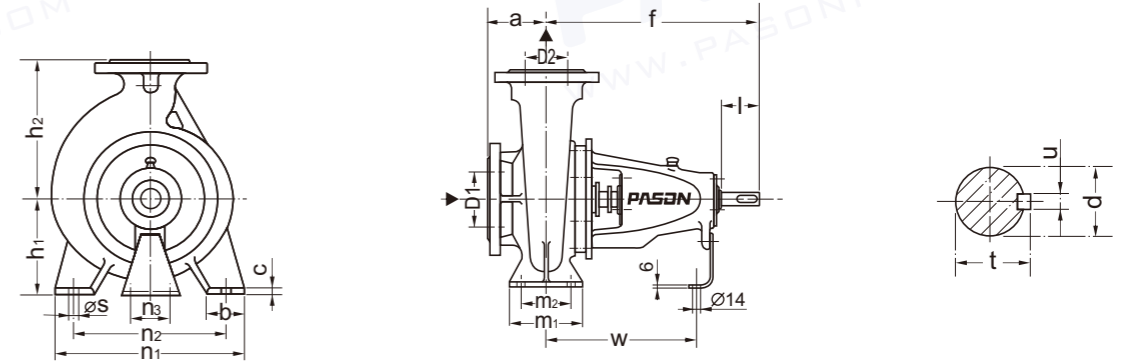

Pump Model	Bearing housing	Pump Dimension								Foot Dimension						Shaft End				Net W.G	
		D2	D1	a	f	h1	h2	b	c	m1	m2	n1	n2	n3	s	w	d	l	t		u
32-13	25	32	50	80	360	112	140	50	14	100	70	190	140	100	14	267	24	50	27	8	30
32-16	25A	32	50	80	360	132	160	50	14	100	70	240	190	100	14	267	24	50	27	8	35
32-20	25	32	50	80	360	160	180	50	14	100	70	240	190	110	14	267	24	50	27	8	47
32-26	25A	32	50	100	360	180	225	65	14	125	95	320	250	110	14	267	24	50	27	8	60
40-13	25	40	65	80	360	112	140	50	14	100	70	210	160	100	14	267	24	50	27	8	31
40-16	25A	40	65	80	360	132	160	50	14	100	70	240	190	100	14	267	24	50	27	8	37
40-20	25	40	65	100	360	160	180	50	14	100	70	265	212	110	14	267	24	50	27	8	48
40-26	25A	40	65	100	360	180	225	65	14	125	95	320	250	110	14	267	24	50	27	8	61
40-32	35	40	65	125	470	200	250	65	14	125	95	345	280	110	14	342	32	80	35	10	100
40-32G	45	40	65	125	526	200	250	65	14	125	95	345	280	110	14	367	42	110	45	12	115
50-13	25	50	65	100	360	132	160	50	14	100	70	240	190	100	14	267	24	50	27	8	35
50-16	25A	50	65	100	360	160	180	50	14	100	70	265	212	110	14	267	24	50	27	8	40
50-20	25	50	65	100	360	160	200	50	14	100	70	265	212	110	14	267	24	50	27	8	50
50-26	25A	50	65	100	360	180	225	65	14	125	95	320	250	110	14	267	24	50	27	8	68
50-26G	35	50	65	100	470	180	225	65	14	125	95	320	250	110	14	344	32	80	35	10	80
50-32	35	50	65	125	470	225	280	65	18	125	95	345	280	110	14	342	32	80	35	10	102
50-32G	45	50	65	125	526	225	280	65	18	125	95	345	280	110	14	367	42	110	45	12	120
65-13	25	65	80	100	360	160	180	65	14	125	95	280	212	110	14	267	24	50	27	8	41
65-16	25A	65	80	100	360	160	200	65	14	125	95	280	212	110	14	267	24	50	27	8	47
65-20	25	65	80	105	360	180	225	65	14	125	95	320	250	110	14	267	24	50	27	8	55
65-20G	35	65	80	105	465	180	225	65	14	125	95	320	250	110	14	339	32	80	35	10	70
65-26	35	65	80	100	470	200	250	80	15	160	120	360	280	110	18	342	32	80	35	10	88
65-32	35	65	80	125	470	225	280	80	18	160	120	400	315	110	18	342	32	80	35	10	115
65-32G	45	65	80	125	526	225	280	80	18	160	120	400	315	110	18	367	42	110	45	12	130
80-16	25A	80	100	125	360	180	225	65	14	125	95	320	250	110	14	267	24	50	27	8	53
80-20	35	80	100	125	470	180	250	65	15	125	95	345	280	110	14	342	32	80	35	10	78
80-26	35	80	100	125	470	200	280	80	15	160	120	400	315	110	18	342	32	80	35	10	98
80-32	35	80	100	125	470	250	315	80	16	160	120	400	315	110	18	342	32	80	35	10	120
80-32G	45	80	100	125	526	250	315	80	16	160	120	400	315	110	18	367	42	110	45	12	140
80-40	45	80	100	125	530	280	355	83	18	160	120	440	340	110	18	370	42	110	45	12	169
100-16	35	100	125	125	470	200	250	80	15	160	120	360	280	110	18	342	32	80	35	10	87
100-20	35	100	125	125	470	200	280	80	16	160	120	360	280	110	18	342	32	80	35	10	85
100-26	35	100	125	140	470	225	280	80	16	160	120	400	315	110	18	342	32	80	35	10	105
100-26G	45	100	125	140	526	225	280	80	16	160	120	400	315	110	18	365	42	110	45	12	125
100-32	35	100	125	140	470	250	315	80	16	160	120	400	315	110	18	342	32	80	35	10	121
100-32G	45	100	125	140	526	250	315	80	16	160	120	400	315	110	18	367	42	110	45	12	145
100-40	45	100	125	140	530	280	355	100	20	200	150	500	400	110	23	370	42	110	45	12	176
125-20	35	125	150	145	470	250	315	80	16	160	120	400	315	110	18	342	32	80	35	10	112
125-26	35	125	150	140	470	250	355	80	16	160	120	400	315	110	18	342	32	80	35	10	117
125-32	45	125	150	140	530	280	355	100	18	200	150	500	400	110	23	370	42	110	45	12	160
125-40	45	125	150	160	530	315	400	100	18	200	150	500	400	110	23	370	42	110	45	12	193
150-20	35	150	200	160	497	280	400	100	18	200	150	400	315	110	23	367	32	80	35	10	133
150-26	45	150	200	160	530	250	355	100	18	200	150	450	350	110	23	370	42	110	45	12	163
150-32	45	150	200	160	530	280	400	100	18	200	150	550	450	110	23	370	42	110	45	12	180
150-40	45	150	200	160	530	315	450	100	18	200	150	550	450	110	23	370					

PA and PAC Series Performance Chart

Performance Chart (50Hz)

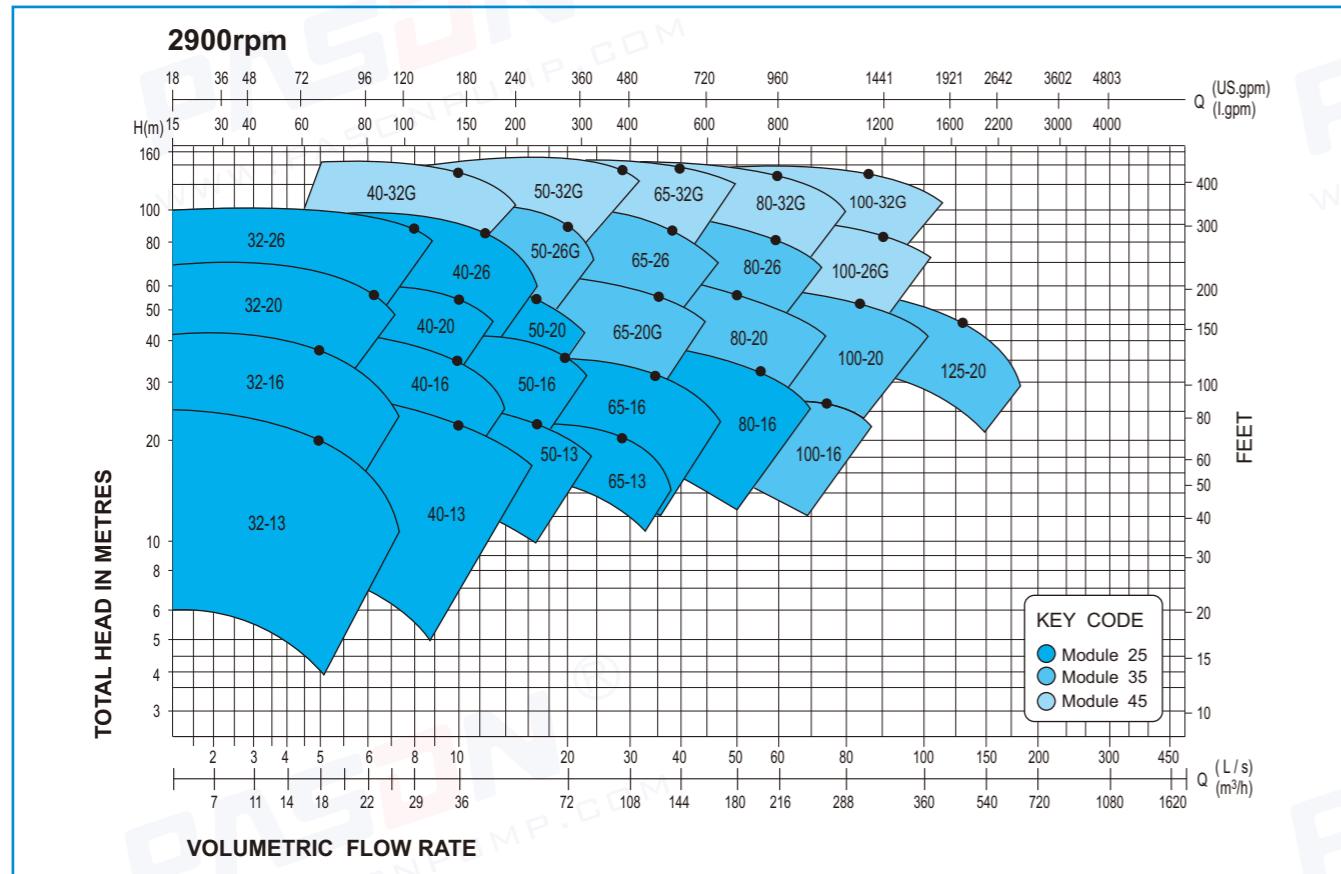

PA and PAC Series Performance Chart

Performance Chart (60Hz)

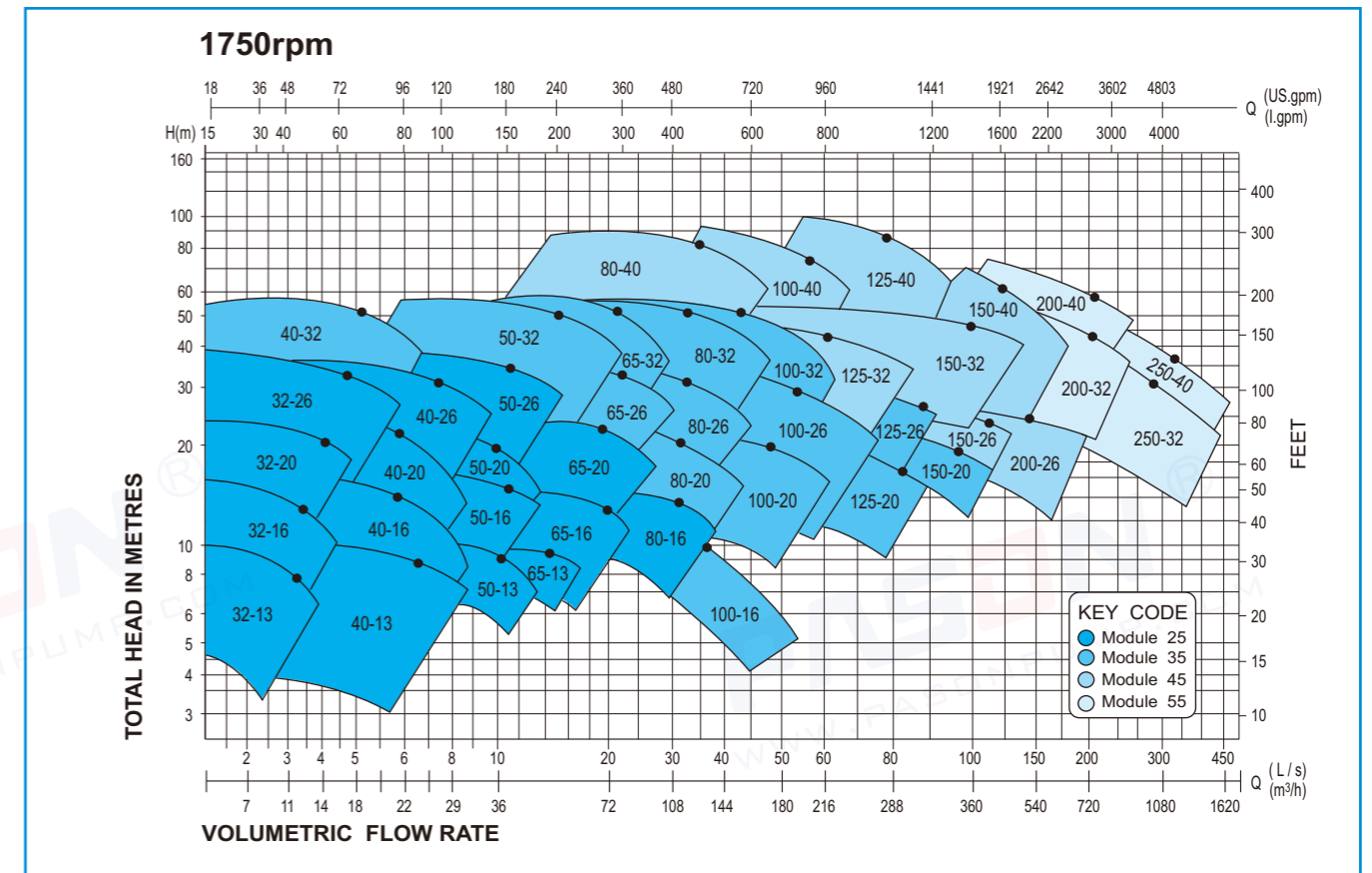
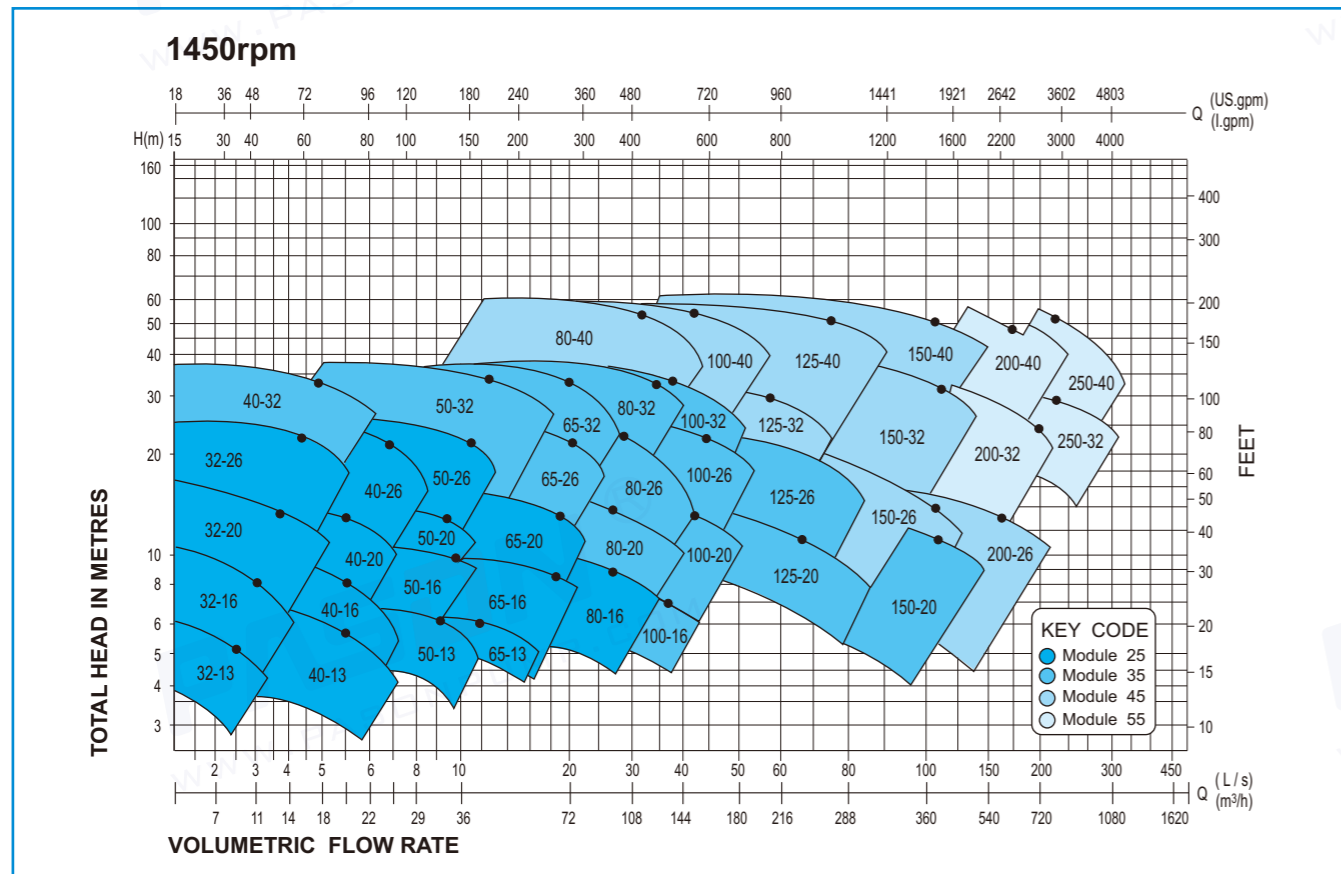
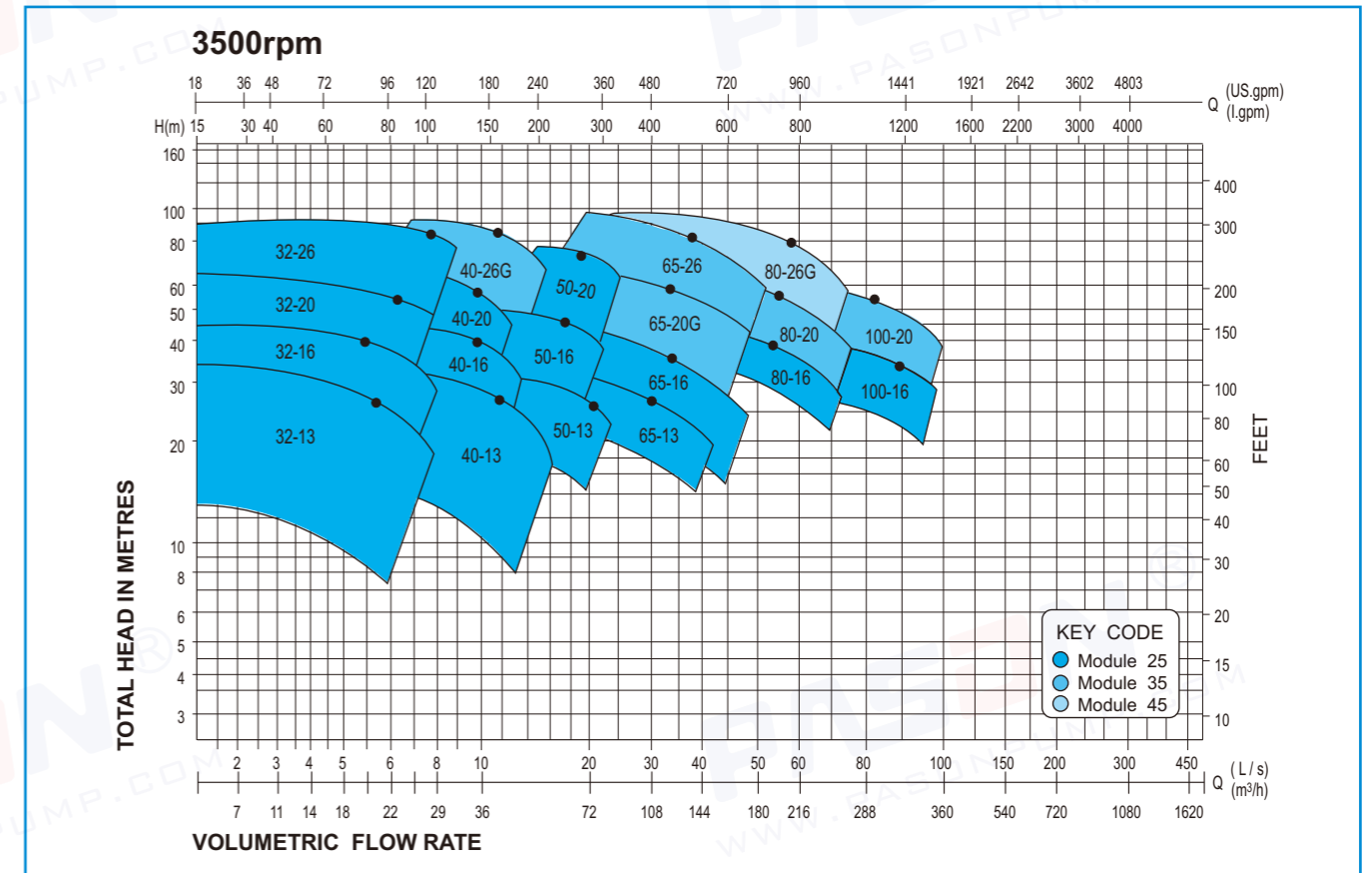

# PAC / PISC Series

## Close-Coupled Centrifugal Pump (DIN24255/ESBN 733 Std and ISO2858/5199 Std)

PAC/PISC pump is the premier solution for pumping clean thin liquids in a very cost-effective way. The pump is part of PASON Pump's Combi-system, a modular programme of Din24255/En 733 and ISO2858/5199 standard single stage centrifugal pumps with a high degree of interchangeability of parts between the PA/PISO series pump constructions



### Operating Limits

Flow up to:	PAC-1100m³/h,	PISC-1900m³/h
Head up to:	PAC-150m,	PISC-160m
Temperature range:	-10 °C +105°C	
Service pressure up to:	up to 16 bar*	

\* depending on model

PAC/PISC series represents a range of horizontal centrifugal pumps close-coupled to IEC standard electric motors. The pump is suitable for handling low-viscosity, clean or slightly contaminated and aggressive liquids.

Characteristic of the PAC pump is the compact configuration of the pump and the electric motor assembly. The use of a stub shaft allows standard IEC electric motors to be used.

Thanks to the small number of components and the use of a mechanical seal, the PAC/PISC requires little maintenance. This is further supported by Back Pull Out of the rotating assembly.

The PAC/PISC has applications in crop farming and market gardening, on board ships and in handling various chemicals.

### Drive Motor:

- By customary IEC standard electric motors, type IM B 35 resp.
- For the determination of the drive power we recommend the following additional power:
  - up to 4 kW: 25 % ;
  - 4 up to 7,5 kW: 20 % ;
  - 7,5 up to 37 kW: 15 %
  - Above 37kw: 10%

Please note: The max. motor power allowed for some construction sizes as shown in the individual curves

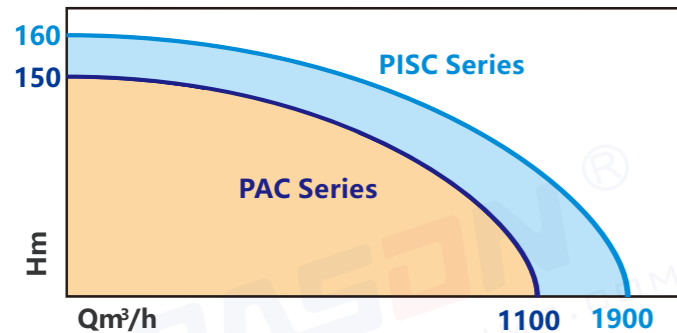

### PAC Model Designation(Examples): PAC 65-16-7.5/2

PAC	65	16	7.5	2
Pump Series	Discharge(mm)	Impeller Nominal Diameter(cm)	Motor power (Kw)	Motor Speed (2Pole or 4Pole)

### PISC Model Designation(Examples): PISC 80X65-160-18.5/2

PISC	80	65	160	18.5	2
Pump Series	Suction(mm)	Discharge(mm)	Impeller Nominal Diameter(mm)	Motor power (Kw)	Motor Speed (2Pole or 4Pole)

### Flange Connecting Dimension( ISO 2084,PN16, ),Option ANSI,JIS10K

DN	Ød	Øk	ØD	n	ØS
32	76	100	140	4	18
40	84	110	150	4	18
50	99	125	165	4	18
65	118	145	185	4	18
80	132	160	200	8	18
100	156	180	220	8	18
125	184	210	250	8	18
150	211	240	285	8	22
200	266	295	340	12	22
250	320	355	405	12	26
300	370	410	460	12	26
350	429	470	520	16	26

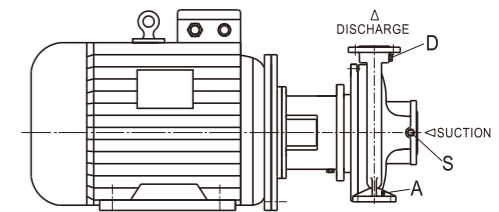
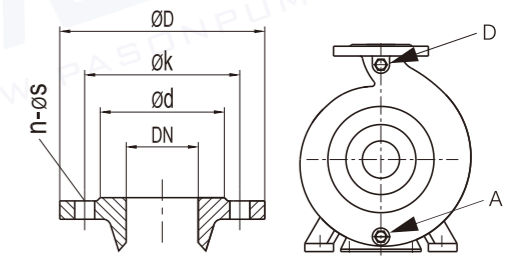

### PAC Service Connections

Pump Model	A D S			Pump Model	A D S		
	Casing Drain	Gauge Drain	Gauge Drain		Casing Drain	Gauge Drain	Gauge Drain
32-13	1/4	1/4	1/4	80-20	1/4	1/4	1/4
32-16	1/4	1/4	1/4	80-26	1/4	1/4	1/4
32-20	1/4	1/4	1/4	80-32	1/4	1/4	1/4
32-26	1/4	1/4	1/4	80-32G	1/4	1/4	1/4
40-13	1/4	1/4	1/4	80-40	1/4	1/4	1/4
40-16	1/4	1/4	1/4	100-16	3/8	1/4	1/4
40-20	1/4	1/4	1/4	100-20	3/8	1/4	1/4
40-26	1/4	1/4	1/4	100-26	3/8	1/4	1/4
40-32	1/4	1/4	1/4	100-26G	3/8	1/4	1/4
40-32G	1/4	1/4	1/4	100-32	3/8	1/4	1/4
50-13	1/4	1/4	1/4	100-32G	3/8	1/4	1/4
50-16	1/4	1/4	1/4	100-40	3/8	1/4	1/4
50-20	1/4	1/4	1/4	125-20	3/8	1/4	1/4
50-26	1/4	1/4	1/4	125-26	3/8	1/4	1/4
50-26G	1/4	1/4	1/4	125-32	3/8	1/4	1/4
50-32	1/4	1/4	1/4	125-40	3/8	1/4	1/4
50-32G	1/4	1/4	1/4	150-20	3/8	1/4	1/4
65-13	1/4	1/4	1/4	150-26	3/8	1/4	1/4
65-16	1/4	1/4	1/4	150-32	3/8	1/4	1/4
65-20	1/4	1/4	1/4	150-40	3/8	1/4	1/4
65-20G	1/4	1/4	1/4	200-26	3/8	1/4	1/4
65-26	1/4	1/4	1/4	200-32	3/8	1/4	1/4
65-32	1/4	1/4	1/4	200-40	3/8	1/4	1/4
65-32G	1/4	1/4	1/4	250-32	3/8	1/4	1/4
80-16	1/4	1/4	1/4	250-40	3/8	1/4	1/4

### PISC Service Connections

Pump Model	A D S			Pump Model	A D S		
	Casing Drain	Gauge Drain	Gauge Drain		Casing Drain	Gauge Drain	Gauge Drain
50X32-160	1/4	1/4	1/4	125X100-500	3/8	3/8	3/8
50X32-200	1/4	1/4	1/4	150X125-250	1/4	1/4	1/4
65X40-200	1/4	1/4	1/4	150X125-315	1/4	1/4	1/4
65X40-250	1/4	1/4	1/4	150X125-400	1/4	1/4	1/4
65X40-315	1/4	1/4	1/4	150X125-500	3/8	3/8	3/8
65X50-160	1/4	1/4	1/4	200X150-315	3/8	3/8	3/8
80X50-200	1/4	1/4	1/4	200X150-400	3/8	3/8	3/8
80X50-250	1/4	1/4	1/4	200X150-500	3/8	3/8	3/8
80X50-315	1/4	1/4	1/4	250X200-200	3/8	3/8	3/8
80X65-160	1/4	1/4	1/4	250X200-250	1/2	1/2	1/2
100X65-200	1/4	1/4	1/4	250X200-315	3/8	3/8	3/8
100X65-250	1/4	1/4	1/4	250X200-400	3/8	3/8	3/8
100X65-315	1/4	1/4	1/4	250X200-500	1/2	1/2	1/2
100X80-160	1/4	1/4	1/4	300X250-250	1/2	1/2	1/2
125X80-400	1/4	1/4	1/4	300X250-315	1/2	1/2	1/2
125X100-200	1/4	1/4	1/4	300X250-400	1/2	1/2	1/2
125X100-250	1/4	1/4	1/4	300X250-500	1/2	1/2	1/2
125X100-315	1/4	1/4	1/4	350X300-400	1/2	1/2	1/2
125X100-400	1/4	1/4	1/4	350X300-500	1/2	1/2	1/2



## PAC / PISC Series

### Close-Coupled Centrifugal Pump (DIN24255/ESBN 733 Std and ISO2858/5199 Std)

#### Features and benefits

##### Pump casing

- flanges according to ISO 7005
- max. working pressure 16 bar
- drain opening
- wide range of applications
- complete and fast draining of the casing

##### Pump cover

- O-ring seal, fully chambered
- machined fits
- perfectly aligned

##### Suction capabilities

- smooth suction entry in pump casing
- smooth surface
- anti rotation vane
- optimum suction capabilities
- minimal flow distortion giving better suction capabilities

##### Impeller locking

- impeller nut with lock washer
- reliable locking

##### Hydraulic balancing

- flat cover for hydraulic balancing
- back vanes for hydraulic balancing
- extended bearing life time

##### Foot

- machined foot
- exact positioning on base and in pipework

##### Materials

- pump casing: cast iron - stainless steel
- impeller: cast iron - stainless steel
- stub shaft: stainless steel
- Shaft seal: Single Mechanical seal



##### Wear rings

Replaceable wear rings are fitted as standard to all casing and also casing cover on larger pumps which reduces maintenance and cost

##### Coupling guard

- consisting of 2 identical parts with snap fit
- Stainless steel
- quick and easy mounting
- for increased safety
- non sparking

##### Electric motor

- standard IEC-B35 size mounted with foot-flange motor
- fixed bearings
- independence of motor make
- economic
- reliable
- readily available

Easy and low cost maintenance  
- pump cover and lantern piece mounted to pump casing as one unit, no separate bolting

- quick and easy impeller replacement
- only 4 mechanical seal sizes
- changeable wear ring
- easy to disassemble pump cover
- economic maintenance
- extended pump life time

##### Lantern piece

- rigid cast iron construction
- machined fits
- large openings
- exact alignment
- easy access for inspection and service

##### Seal chamber / Mechanical Seal

The standard pumps are fitted with single mechanical seal

- the casing cover which are only for mechanical seals have open chambers allowing more water to flush mechanical seal.
- no external flushing piping needed

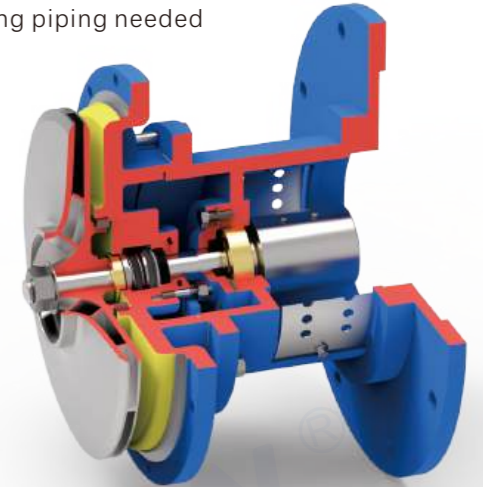

##### Shaft sealing

- mechanical bellows seal according to EN 12756 (DIN 24960 L<sub>1k</sub>)
- several material combinations
- no O-ring lock up
- interchangeable with other EN (DIN) seal makes
- suitable for many liquids

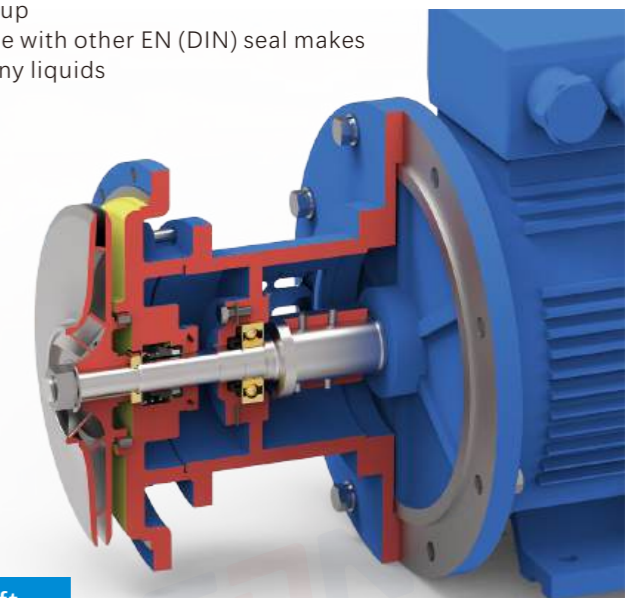

##### Stub shaft

- stainless steel
- fits to IEC electric motors
- axial fixation with set screws
- 4 shaft diameters
- no shaft sleeve needed
- easy impeller replacement
- adjustable axial impeller position
- low maintenance cost

# PISO Series

## ISO2858/5199 Std End Suction Back Pull-Out Centrifugal Pump

### Design & Features

PISO design is in accordance with international standards of ISO2858/5199, which means PISO Series pumps are interchangeable with other similar pumps, conforming to the same standards. This ensures a robust, long lasting, high performing product consumers can come to depend on from Preeminence.



### Applications

Water Supply Systems	Pressure Boosting	Heating Systems for Commercial District Heating
Fire Fighting Systems	General Transport for Industrial Processes	Cooling Plants for Industrial Processing and Air-Conditioning units

### Model Designation(Examples): PISO 300X250-500

PISO	300	250	500
Series	Suction(mm)	Discharge(mm)	Impeller Nominal Diameter(mm)

### Pump Casing

highly efficient cast iron volute casings, with flanges rated to PN1.6MPa (16bar), drilled to ISO7005.2 : 1988).

### Enlarge Shaft

reduces shaft deflection. Standard in SS420, SS304&SS316 as an option. Tapered & keyed shaft design allowing ease of removal in maintenance & positive locking whilst in operation

### Bearings

Heavy duty NTN or approved equivalent, greased for life, reducing maintenance. Protected by a quality manufactured lip seal reducing ingress of moisture or foreign matter. Housed within removable bearing cap cover assembly

### Bearing housing

Robust / heavy duty, manufactured in high strength cast iron providing trouble-free life complete with lifting provision and support foot.

### Shaft seal

single, high quality John Crane or approved equivalent mechanical seal with carbon vs ceramic/viton fitted as standard to all PISO Series pumps with other options such as Silicone vs Silicone or high temp also available.

### Wear Ring

Cast Iron wear rings - fitted as standard, replaceable front & rear wear rings with optional materials, for a trouble-free lifecycle.

### Casing O-Ring

Re-usable o-rings in Nitrile for ease of re-assembly

### Tappings

Convenient suction & discharge pressure gauge tappings plus volute drain, fitted as standard to all PISO Series pumps.

### Painting

Prior to painting, the pump is thoroughly cleaned of foreign material. The pump is then painted with a high quality/ undercoat/ primer and industrial enamel paint.

### Accessories

#### Drive

The pump is only recommended for direct drive via a flexible spacer coupling. Spacer couplings enable the utilization of the back pull out feature.

Where belt drives are necessary a separate jack (intermediate) shaft with bearings to carry the belt loads may be required.

All drive systems, where supplied by PASON PUMP are appropriately protected by suitable guards.

### Pump Selection

For pump selection the hydraulic performance curves should be used. These curves are based on water at 15°C and SG equal to 1.0.

NPSH values are indicated on the performance curves. At least 0.5m should be added as a safety margin

To overcome variations between actual and design requirements it is recommended that the driver power exceeds the absorbed pump shaft power.

Absorbed Pump Shaft kW	Driver Power Reserve
up to 7.5	Approx. 20%
7.5~40	Approx. 15%
Above 40	Approx. 10%

### Impeller

Cast Iron/SS304/SS316 impeller-fitted as standard, in a closed design is fitted as standard to prevent corrosion in stationary or inactive situations. The use of 3-D solid model (CAD) Computer Aided Design and (CFD) Computational Fluid Dynamics ensures high efficiencies, reducing overall running costs. Impeller diameters can be trimmed to suit specified performance. PISO impellers are dynamically balanced, providing smooth, vibration free operation, preventing premature bearing failure.

Back pull-out design - allowing for easy removal of rotating element without disturbing the pipework, lagging or pump volute casing. This is proven to reduce downtime whilst performing routine maintenance.

**PISO Series** ISO2858/5199 Std End Suction Back Pull-Out Centrifugal Pump

**Design**

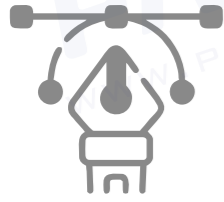

<b>Design</b>	Performance and dimension as per ISO 2858/5199
<b>Structure</b>	Horizontal ,End suction, Single suction,Volute casing
<b>DN(mm)</b>	Suction size: 50~350, Discharge size: 32~300
<b>Flange</b>	DIN 2501,PN16

**Material**

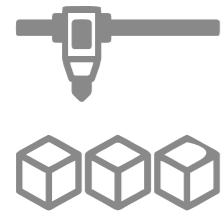

<b>Pump parts</b>	Material
<b>Casing / Impeller</b>	Cast iron/Stainless steel
<b>Shaft</b>	Stainless steel
<b>Shaft seal</b>	Mechanical Seal
<b>Bearing lubrication</b>	Grease Life
<b>Bearing Brand</b>	NTN

**Operating Data**

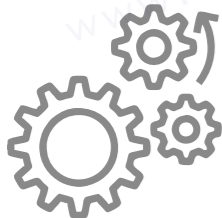

<b>Speed</b>	Up to 3600rpm
<b>Flow Rate(Q)</b>	Up to 1900m³/h-1450rpm 2430m³/h-1750rpm
<b>Head(H)</b>	Up to 160m
<b>Pressure</b>	PN16 as standard
<b>Liquid Temperature</b>	Up to 105°C

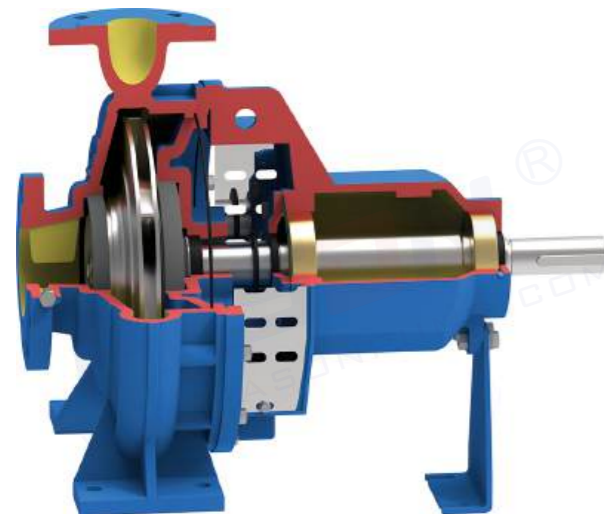

S/N	Part Name
1	Pump Casing
2.1/2.2	Wear Ring
3	Impeller
4	O-Ring
5.1	Casing Cover
5.2	Casing Cover (Gland Packing)
6.1/6.2	Deep groove ball bearing
6.3	Cylindrical roller bearing
6.4	Angular contact ball bearing
7	Nameplate
8.1	Standard Bearing Housing
8.2	Heavy duty Bearing Housing
9.1/9.2	Oil Seal
10	Shaft
11	Coupling Key
12	Support Foot
13.1/13.2	Bearing cover
14	Slinger
15	Single mechanical seal
16	Woodruff key
17	Impeller Washer
18	Impeller Nut
19	Oil hole cover
20	Tab washer
21	Round Nut
22	Oil indicator
23	Drain plug
26	Packing, Shaft Sleeve
28	Packing Gland
29	Gland Packing
30	Lantern Ring

**Section Drawing**

**Standard--Single seal**

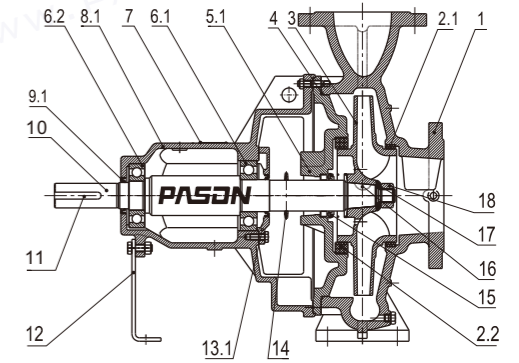

**Optional**

**Heavy Duty bearing**

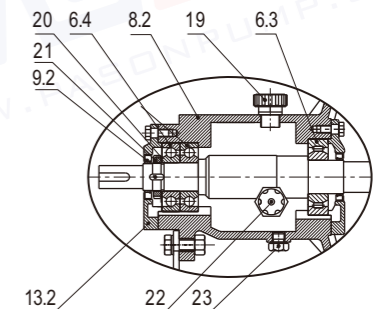

**Packing Seal**

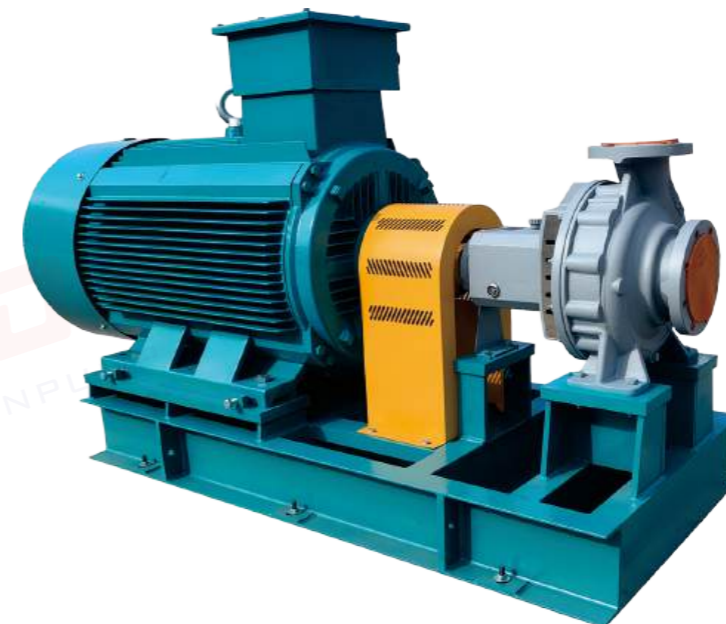
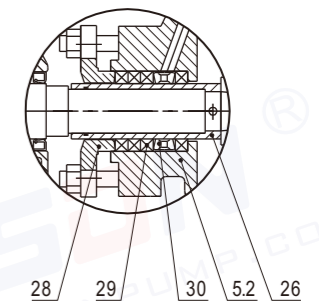

PISO Series

ISO2858/5199 Std End Suction Back Pull-Out Centrifugal Pump

Intalling Dimension

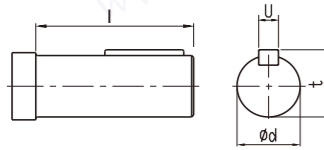

Drive Shaft Dimensions

Shaft No	ød	l	u	t
1	24	50	8	27
2	32	80	10	35
3	42	110	12	45
4	48	110	14	51.5
5	65	140	18	69
6	75	170	20	79.5

Flange Connecting Dimension( ISO 2084,PN16)

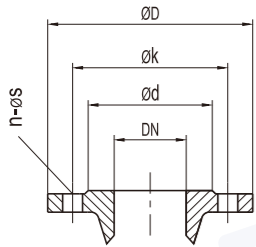

DN	ød	øk	øD	n	øS
32	76	100	140	4	18
40	84	110	150	4	18
50	99	125	165	4	18
65	118	145	185	4	18
80	132	160	200	8	18
100	156	180	220	8	18
125	184	210	250	8	18
150	211	240	285	8	22
200	266	295	340	12	22
250	320	355	405	12	26
300	370	410	460	12	26
350	429	470	520	16	26

Notes: 1. Optional Flange: AS2129-1982, ANSI 16.1-1975, JISB 2210-1984

Service Connections

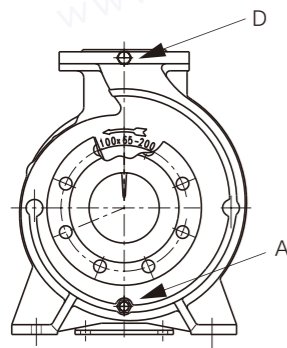

Pump Model	Casing Drain	Housing Drain	Gauge Drain	Gauge Drain
50X32-160	1/4	3/8	1/4	1/4
50X32-200	1/4	3/8	1/4	1/4
65X40-200	1/4	3/8	1/4	1/4
65X40-250	1/4	3/8	1/4	1/4
65X40-315	1/4	3/8	1/4	1/4
65X50-160	1/4	3/8	1/4	1/4
80X50-200	1/4	3/8	1/4	1/4
80X50-250	1/4	3/8	1/4	1/4
80X50-315	1/4	3/8	1/4	1/4
80X65-160	1/4	3/8	1/4	1/4
100X65-200	1/4	3/8	1/4	1/4
100X65-250	1/4	3/8	1/4	1/4
100X65-315	1/4	3/8	1/4	1/4
100X80-160	1/4	3/8	1/4	1/4
125X80-400	1/4	3/8	1/4	1/4
125X100-200	1/4	3/8	1/4	1/4
125X100-250	1/4	3/8	1/4	1/4
125X100-315	1/4	3/8	1/4	1/4
125X100-400	1/4	3/8	1/4	1/4

Pump Model	Casing Drain	Housing Drain	Gauge Drain	Gauge Drain
125X100-500	3/8	3/8	3/8	3/8
150X125-250	1/4	3/8	1/4	1/4
150X125-315	1/4	3/8	1/4	1/4
150X125-400	1/4	3/8	1/4	1/4
150X125-500	3/8	3/8	3/8	3/8
200X150-315	3/8	3/8	3/8	3/8
200X150-400	3/8	3/8	3/8	3/8
200X150-500	3/8	3/8	3/8	3/8
250X200-200	3/8	3/8	3/8	3/8
250X200-250	1/2	3/8	1/2	1/2
250X200-315	3/8	3/8	3/8	3/8
250X200-400	3/8	3/8	3/8	3/8
250X200-500	1/2	3/8	1/2	1/2
300X250-250	1/2	3/8	1/2	1/2
300X250-315	1/2	1/2	1/2	1/2
300X250-400	1/2	3/8	1/2	1/2
300X250-500	1/2	3/8	1/2	1/2
350X300-400	1/2	1/2	1/2	1/2
350X300-500	1/2	1/2	1/2	1/2

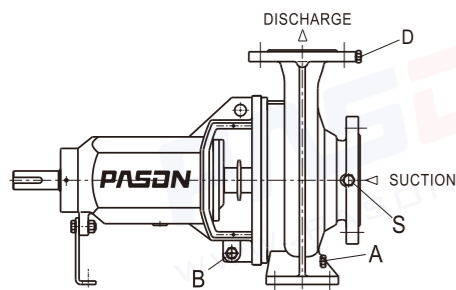

Dimensions-Bare Shaft Pump

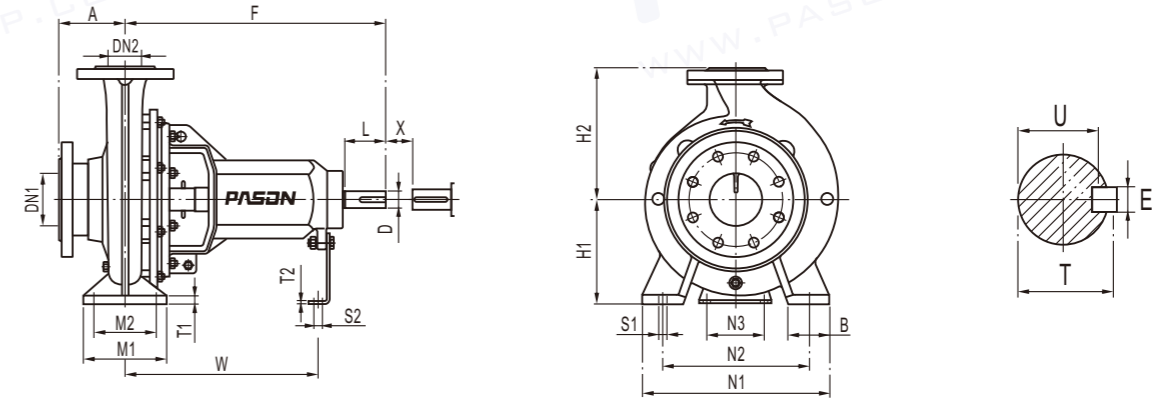

Pump Model	Shaft No.	Flange Size		Pump Dimensions				Foot Dimensions						Bolt Holes		Shaft End					Spacer X ≥	Net. Weight			
		DN1	DN2	A	F	H1	H2	B	M1	M2	N1	N2	N3	W	T1	T2	S1	S2	D	L			T	E	U
50X32-160	1	50	32	80	385	132	160	50	100	70	240	190	110	285	12	6	M12	M12	24	50	27	8	20	100	38
50X32-200	1	50	32	80	385	160	180	50	100	70	240	190	110	285	12	6	M12	M12	24	50	27	8	20	100	46
65X40-200	1	65	40	100	385	160	180	50	100	70	265	212	110	285	13	6	M12	M12	24	50	27	8	20	100	48
65X40-250	2	65	40	100	500	180	225	65	125	95	320	250	110	370	14	6	M12	M12	32	80	35	10	27	100	70
65X40-315	2	65	40	125	500	200	250	65	125	95	345	280	110	370	16	6	M12	M12	32	80	35	10	27	100	80
65X50-160	1	65	50	80	385	132	160	50	100	70	240	190	110	285	11	6	M12	M12	24	50	27	8	20	100	40
80X50-200	1	80	50	100	385	160	200	50	100	70	265	212	110	285	13	6	M12	M12	24	50	27	8	20	100	52
80X50-250	2	80	50	125	500	180	225	65	125	95	320	250	110	370	15	6	M12	M12	32	80	35	10	27	100	72
80X50-315	2	80	50	125	500	225	280	65	125	95	345	280	110	370	18	6	M12	M12	32	80	35	10	27	100	87
80X65-160	1	80	65	100	385	160	180	50	100	70	265	212	110	285	11	6	M12	M12	24	50	27	8	20	100	46
100X65-200	2	100	65	100	500	180	225	65	125	95	320	250	110	370	14	6	M12	M12	32	80	35	10	27	140	70
100X65-250	2	100	65	125	500	200	250	80	160	120	360	280	110	370	16	6	M16	M12	32	80	35	10	27	140	80
100X65-315	3	100	65	125	530	225	280	80	160	120	400	315	110	370	18	6	M16	M12	42	110	45	12	37	140	142
100X80-160	2	100	80	100	500	160	200	65	125	95	280	212	110	370	14	6	M12	M12	32	80	35	10	27	100	68
125X80-400	3	125	80	125	530	280	355	80	160	120	435	355	110	370	20	6	M16	M12	42	110	45	12	37	140	165
125X100-200	2	125	100	125	500	200	280	80	160	120	360	280	110	370	17	6	M16	M12	32	80	35	10	27	140	85
125X100-250	3	125	100	140	530	225	280	80	160	120	400	315	110	370	18	6	M16	M12	42	110	45	12	37	140	126
125X100-315	3	125	100	140	530	250	315	80	160	120	400	315	110	370	19	6	M16	M12	42	110	45	12	37	140	135
125X100-400	3	125	100	140	530	280	355	100	200	150	500	400	110	370	20	6	M20	M12	42	110	45	12	37	140	175
125X100-500	4	125	100	160	670	355	450	100	200	150	550	450	140	500	25	10	M20	M16	48	110	51.5	14	42.5	180	338
150X125-250	3	150	125	140	530	250	355	80	160	120	400	315	110	370	19	6	M16	M12	42	110	45	12	37	140	140
150X125-315	3	150	125	140	530	280	355	100	200	150	500	400	110	370	20	6	M20	M12	42	110	45	12	37	140	150
150X125-400	3	150	125	140	530	315	400	100	200	150	500	400	110	370	21	6	M20	M12	42	110	45	12	37	140	186
150X125-500	4	150	125	160	670	355	450	100	200	150	550	450	140	500	25	10	M20	M16	48	110	51.5	14	42.5	180	350
200X150-315	4	200	150	160	670	315	400	100	200	150	550	450	140	500	25	10	M20	M16	48	110	51.5	14	42.5	180	222
200X150-400	4	200	150	160	670	315	450	100	200	150	550	450	140	500	25	10	M20	M16	48	110	51.5	14	42.5	180	300
200X150-500	4	200	150	160	670	400	500	100	200	150	550	450	140	500	25	10	M20	M16	48	110	51.5	14	42.5	180	382
250X200-200	4	250	200	180	670	315	450	100	200	150	550	450	140	500	22	10	M20	M16	48	110	51.5	14	42.5	180	345
250X200-250	5	250	200	180	885	315	450	100	200	150	550	450	180	670	25	12	M24	M16	65	140	69	18	58	250	490
250X200-315	4	250	200	180	670	315	450	100	200	150	550	450	140	500	25	10	M20	M16	48	110	51.5	14	42.5	180	277
250X200-400	4	250	200	180	670	355	500	100	200	150	550	450	140	500	25	10	M20	M16	48	110	51.5	14	42.5	180	380
250X200-500	5	250	200	225	885	400	580	150	315	250	760	630	180	670	28	12	M24	M16	65	140	69	18	5		

**PISO Series** ISO2858/5199 Std End Suction Back Pull-Out Centrifugal Pump

Performance Chart (50Hz)

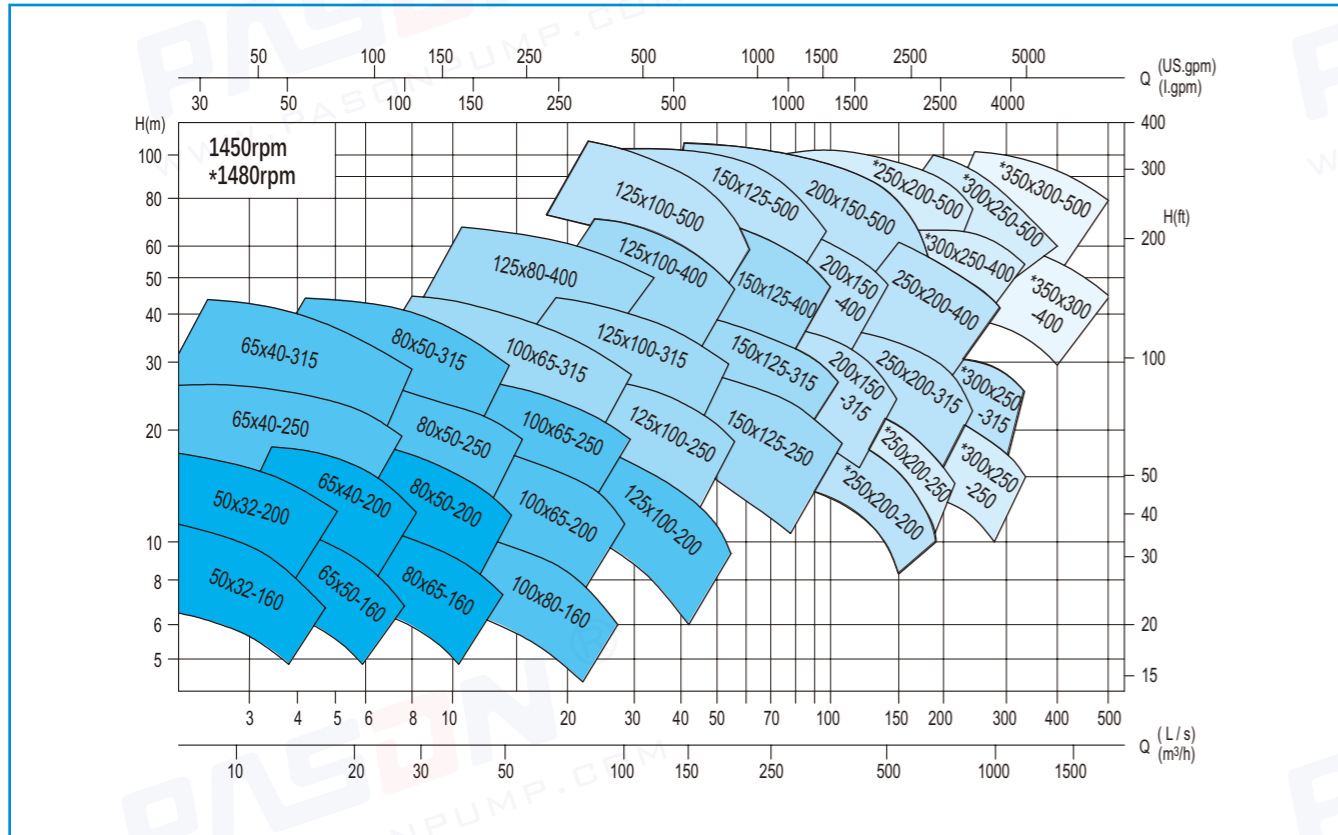

**PISO Series** ISO2858/5199 Std End Suction Back Pull-Out Centrifugal Pump

Performance Chart (60Hz)

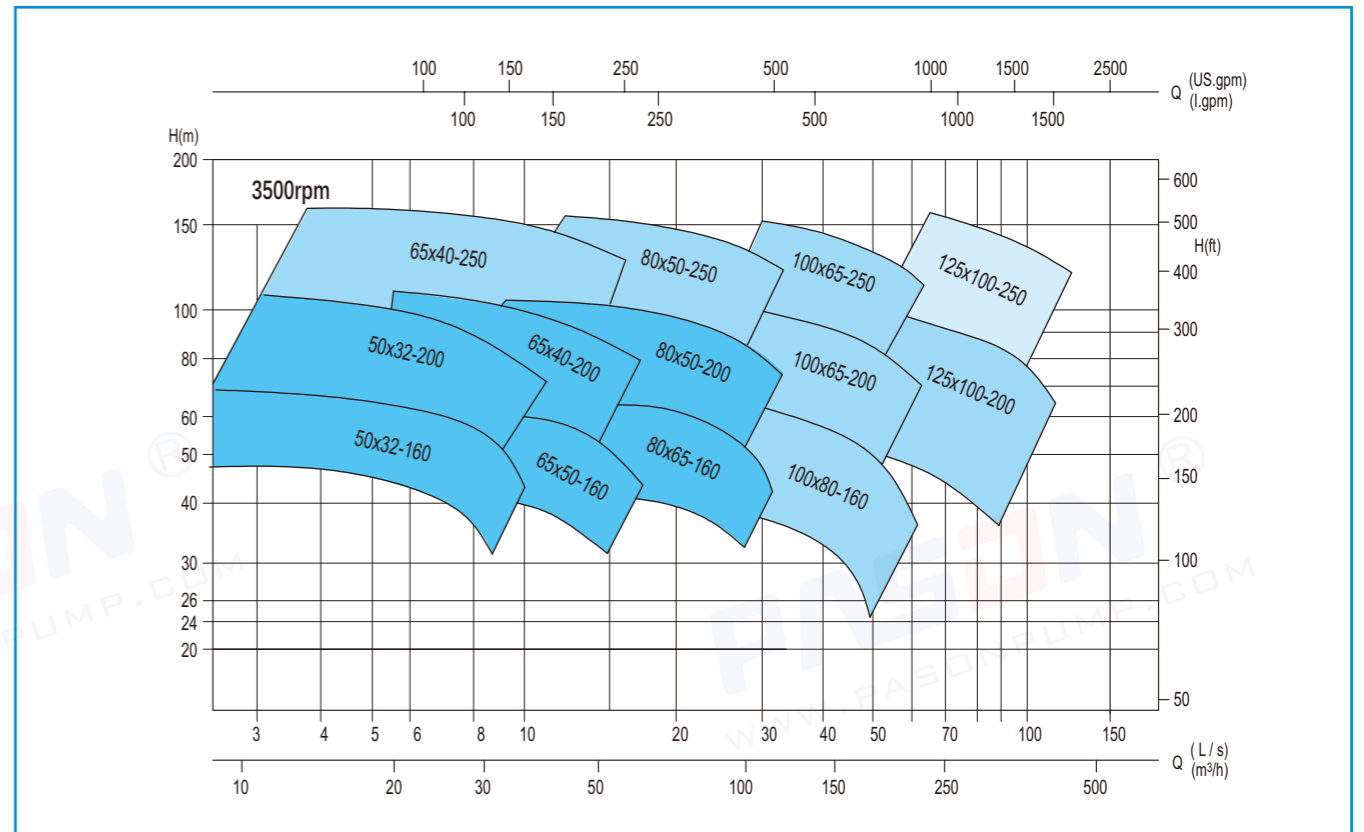
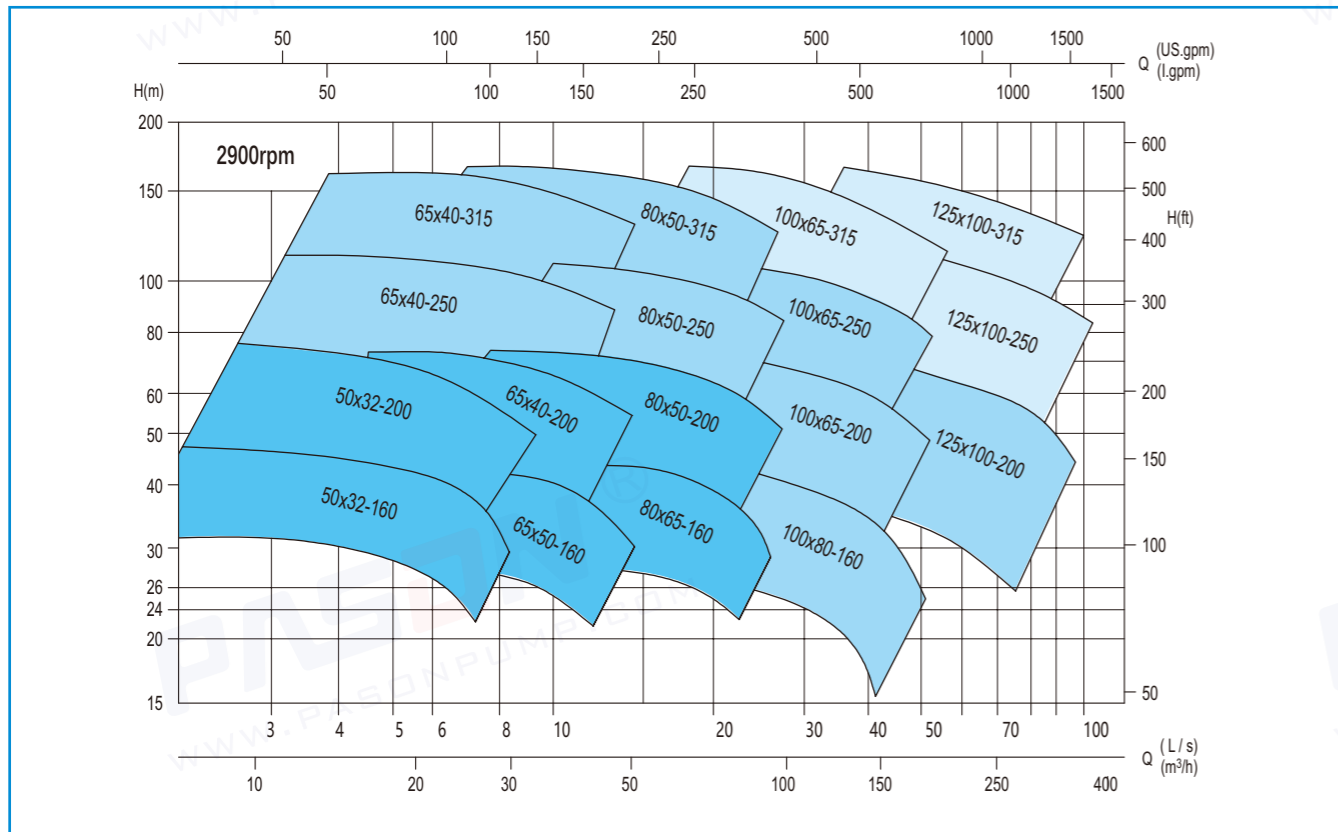
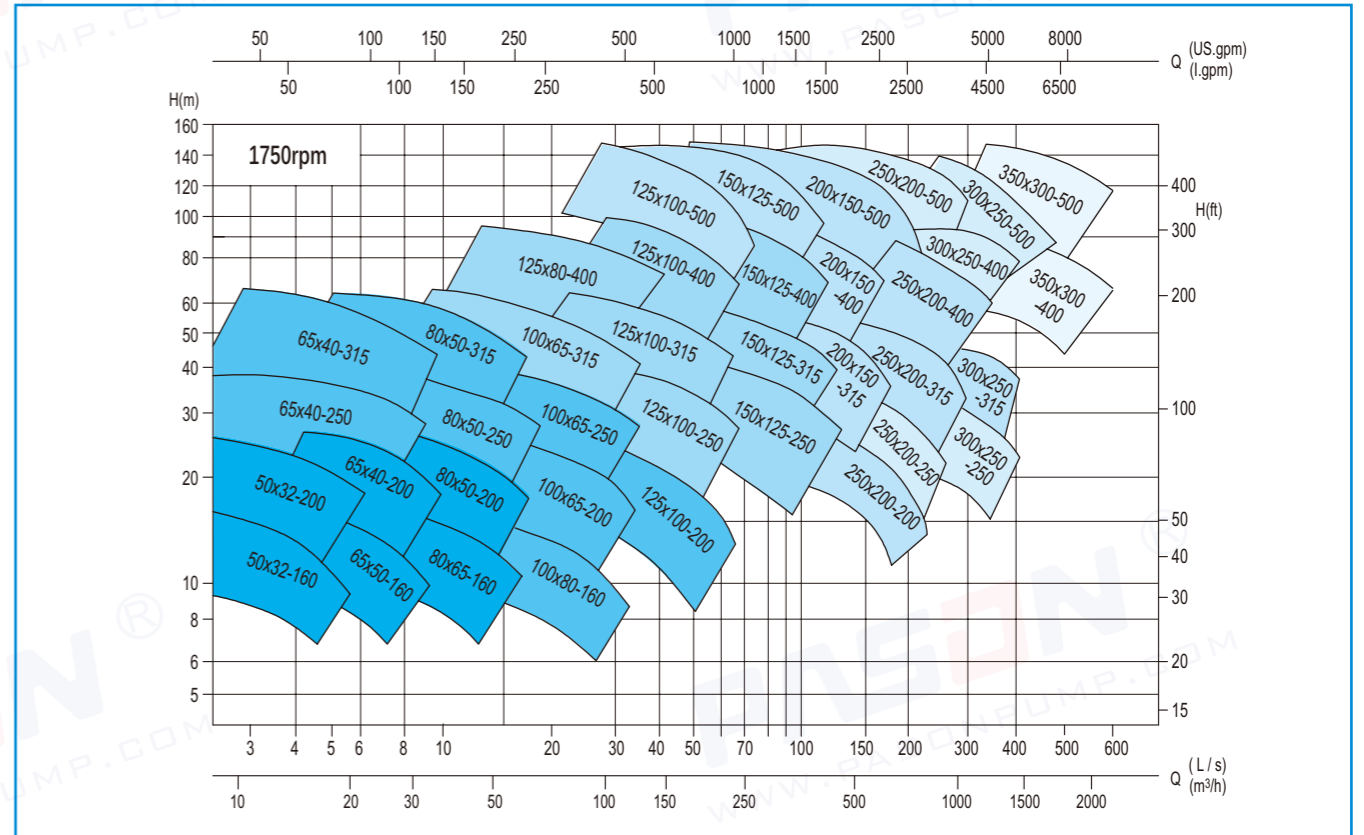

# PCC Series

Chemical Process Pump  
(ISO5199/2858, EN 25199/22858 Std)

## Design & Features

PCC design is in accordance with international standards of ISO5199/2858, EN 25199/22858, DIN24256. which means PCC Series pumps are interchangeable with other similar pumps, conforming to the same standards. This ensures a robust, long lasting, high performing product consumers can come to depend on from Preeminence.



Design	Performance and dimension as per ISO 2858/5199
Structure	Horizontal ,End suction, Single suction,Volute casing
DN(mm)	Suction size: 50~350, Discharge size: 32~300
Flange	DIN 2501,PN16

## Design

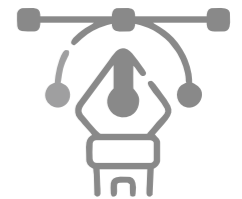

Pump parts	Material
Casing / Impeller	Stainless steel 304/316/316L/2205/2507
Shaft	Stainless steel
Shaft seal	Mechanical Seal
Bearing lubrication	Grease life,Grease, Oil lubrication
Bearing Brand	NTN

## Material

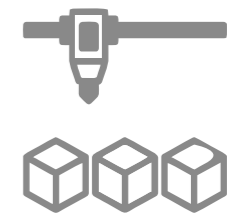

## Applications

Chemical and Petrochemical Industry

Oil refining plants

Paper making industry

Sugar Industry

Waste Water Treatment

Pharmaceutical Food Industry

Speed	Up to 3600rpm
Flow Rate(Q)	Up to 1900m³/h-1450rpm 2430m³/h-1750rpm
Head(H)	Up to 160m
Pressure	Up to PN24
Liquid Temperature	Up to 120 °C

## Operating Data

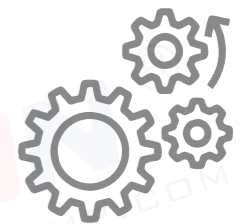

Model Designation(Examples): PCC 125X100-315

PCC

Series

125

Suction(mm)

100

Discharge(mm)

315

Impeller Nominal Diameter(mm)

**PCC Series** Chemical Process Pump (ISO5199/2858, EN 25199/22858 Std)

**Main Construction Features:**

**Impeller/Shaft connection and seal**

The impeller and shaft are fitted with taper, which increase the strength of the shaft

**Impeller / Casing**

Optimized Hydraulic design with impeller diameter up to 547mm, PCC pumps have wider performance coverage than EN 25199/22858

**Shaft seal**

Single, Double mechanical seal, Cartridge mechanical seal, Gland packing are available

**Axial Force Balance**

The axial force are mostly balance by the front/rear wearing rings and balanceing holes in impeller design, The residual axial force are balanced by the back to back arranged contact ball bearings at the drive end.

**Flange**

Flange dimensions comply to ISO 7005-1:1992 PN16 Mpa as standard, other flange(including ANSI flange) are also available by request

**Heavy Duty Bearings**

Cylindrical roller bearing at the impeller end, two of angular contact ball bearing(back to back arrangement) at the drive end. Design bearing life up to 25000 hours.

**Application**

The PCC centrifugal pump is suitable for handling water or similar liquids mainly used in the following.

- Chemical and Petrochemical Industry
- Oil refining plants
- Paper making industry
- Waste water treatment
- Pharmaceutical
- Food Industry

**Pumped Liquids**

- Water
- Acid
- Alkaline
- Ammonia
- Other corrosive and abrasive liquids

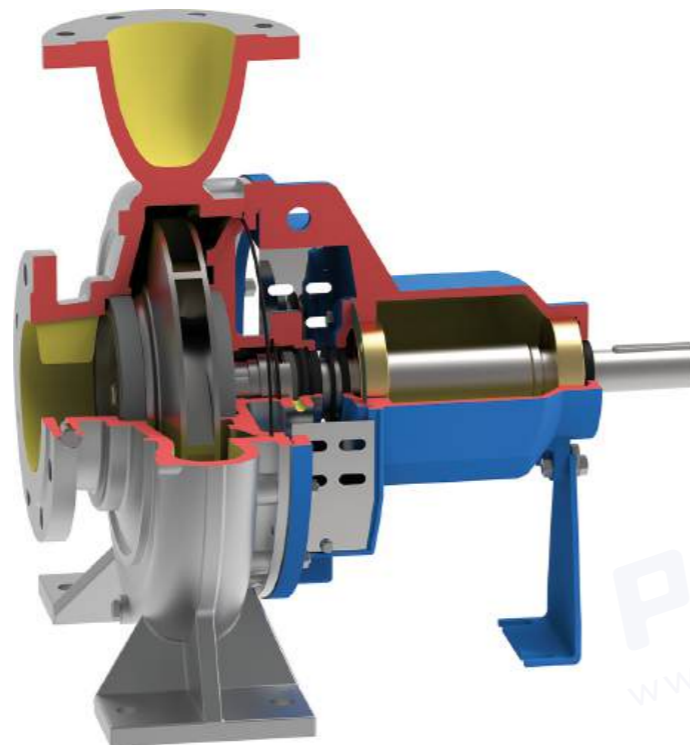

**Section Drawing**

**Standard-Single seal**

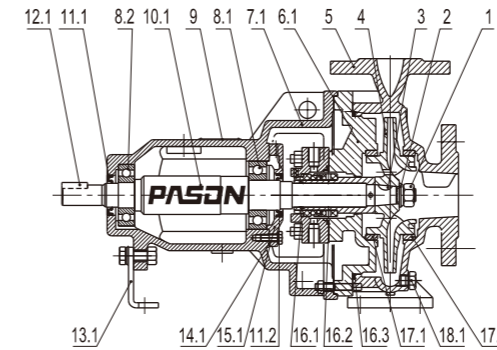

**Single Seal**

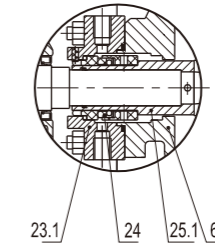

**Option-Heavy Duty**

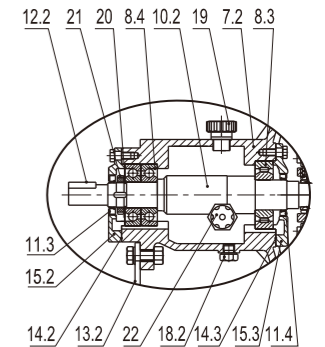

**Optional**

**Packing Seal**

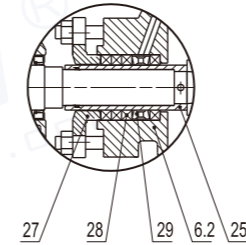

**Double Seal**

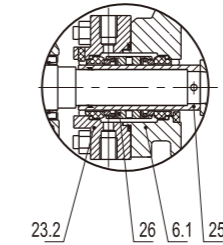

**Cartridge Seal**

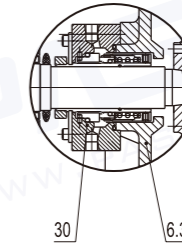

**Dynamic Seal**

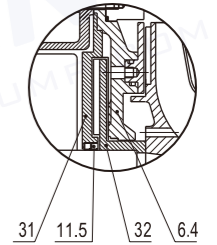

S/N	Part Name
1	Impeller Nut
2	Impeller Washer
3	Woodruff key
4	Impeller
5	Pump Casing
6.1	Casing Cover(Single/Double mech seal)
6.2	Casing Cover(Packing seal)
6.3	Casing Cover(Cartridge Seal)
6.4	Casing Cover(Dynamic seal)
7.1	Bearing Housing (Standard)
7.2	Bearing Housing(Heavy duty)
8.1/8.2	Deep groove ball bearing
8.3	Cylindrical roller bearing
8.4	Angular contact ball bearing
9	Nameplate
10.1	Shaft(standard)
10.2	Shaft(Heavy)
11.1-11.5	Oil Seal
12.1/12.2	Coupling Key
13.1/13.2	Support Foot
14.1/14.2/14.3	Gasket Paper

S/N	Part Name
15.1/15.2/15.3	Bearing Cover
16.1/16.2/16.3	O-Ring
17.1/17.2	Wear Ring
18.1/18.2	Drain plug
19	Oil hole cover
20	Tab washer
21	Round Nut
22	Oil Indicator
23.1/23.2	Seal Gland
24	Single Mechanical seal
25.1	Shaft Sleeve (Single mech.)
25.2	Shaft Sleeve(Double Mech.)
25.3	Shaft Sleeve(Packing)
26	Double mechanical seal
27	Packing Gland
28	Gland Packing
29	Lantern Ring
30	Cartridge Seal
31	Seal Plate
32	Vice impeller

**PCC Series** Chemical Process Pump (ISO5199/2858, EN 25199/22858 Std)

**Intalling Dimension**

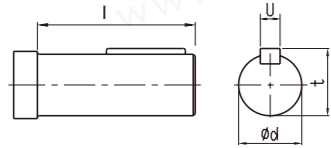

**Drive Shaft Dimensions**

Shaft No	ød	l	u	t
1	24	50	8	27
2	32	80	10	35
3	42	110	12	45
4	48	110	14	51.5
5	65	140	18	69
6	75	170	20	79.5

**Flange Connecting Dimension( ISO 2084,PN16)**

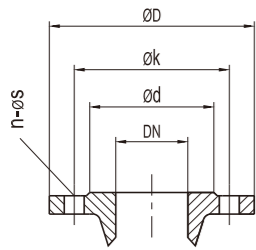

DN	ød	øk	øD	n	øS
32	76	100	140	4	18
40	84	110	150	4	18
50	99	125	165	4	18
65	118	145	185	4	18
80	132	160	200	8	18
100	156	180	220	8	18
125	184	210	250	8	18
150	211	240	285	8	22
200	266	295	340	12	22
250	320	355	405	12	26
300	370	410	460	12	26
350	429	470	520	16	26

Notes: 1. Optional Flange: AS2129-1982, ANSI 16.1-1975, JISB 2210-1984

**Service Connections**

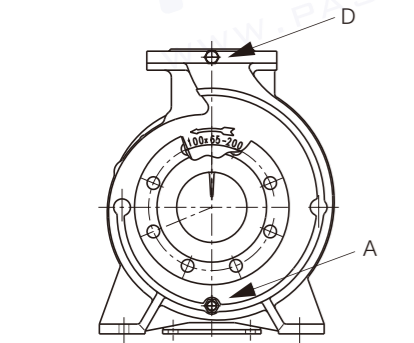

Pump Model	A	B	D	S
	Casing Drain	Housing Drain	Gauge Drain	Gauge Drain
50X32-160	1/4	3/8	1/4	1/4
50X32-200	1/4	3/8	1/4	1/4
65X40-200	1/4	3/8	1/4	1/4
65X40-250	1/4	3/8	1/4	1/4
65X40-315	1/4	3/8	1/4	1/4
65X50-160	1/4	3/8	1/4	1/4
80X50-200	1/4	3/8	1/4	1/4
80X50-250	1/4	3/8	1/4	1/4
80X50-315	1/4	3/8	1/4	1/4
80X65-160	1/4	3/8	1/4	1/4
100X65-200	1/4	3/8	1/4	1/4
100X65-250	1/4	3/8	1/4	1/4
100X65-315	1/4	3/8	1/4	1/4
100X80-160	1/4	3/8	1/4	1/4
125X80-400	1/4	3/8	1/4	1/4
125X100-200	1/4	3/8	1/4	1/4
125X100-250	1/4	3/8	1/4	1/4
125X100-315	1/4	3/8	1/4	1/4
125X100-400	1/4	3/8	1/4	1/4

Pump Model	A	B	D	S
	Casing Drain	Housing Drain	Gauge Drain	Gauge Drain
125X100-500	3/8	3/8	3/8	3/8
150X125-250	1/4	3/8	1/4	1/4
150X125-315	1/4	3/8	1/4	1/4
150X125-400	1/4	3/8	1/4	1/4
150X125-500	3/8	3/8	3/8	3/8
200X150-315	3/8	3/8	3/8	3/8
200X150-400	3/8	3/8	3/8	3/8
200X150-500	3/8	3/8	3/8	3/8
250X200-200	3/8	3/8	3/8	3/8
250X200-250	1/2	3/8	1/2	1/2
250X200-315	3/8	3/8	3/8	3/8
250X200-400	3/8	3/8	3/8	3/8
250X200-500	1/2	3/8	1/2	1/2
300X250-250	1/2	3/8	1/2	1/2
300X250-315	1/2	1/2	1/2	1/2
300X250-400	1/2	3/8	1/2	1/2
300X250-500	1/2	3/8	1/2	1/2
350X300-400	1/2	1/2	1/2	1/2
350X300-500	1/2	1/2	1/2	1/2

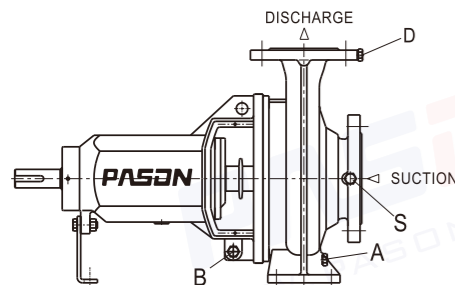

**Dimensions-Bare Shaft Pump**

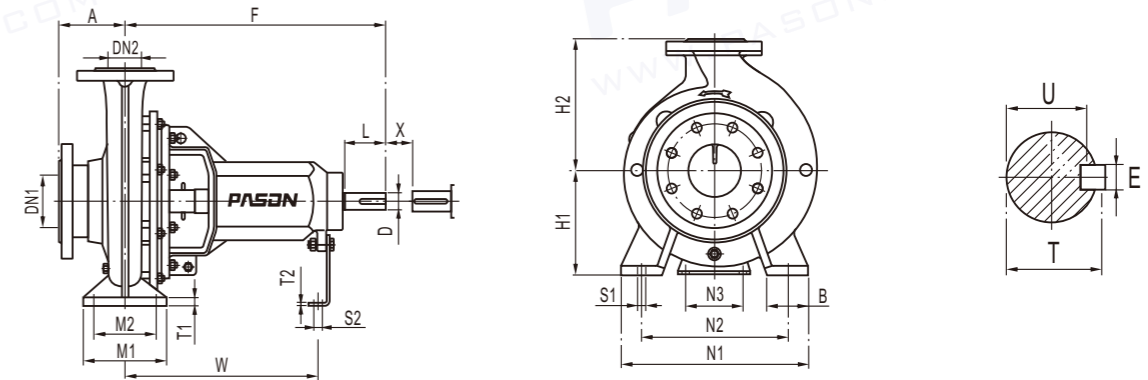

Pump Model	Shaft No.	Flange Size		Pump Dimensions				Foot Dimensions						Bolt Holes		Shaft End					Spacer X ≥	Net. Weight			
		DN1	DN2	A	F	H1	H2	B	M1	M2	N1	N2	N3	W	T1	T2	S1	S2	D	L			T	E	U
50X32-160	1	50	32	80	385	132	160	50	100	70	240	190	110	285	12	6	M12	M12	24	50	27	8	20	100	38
50X32-200	1	50	32	80	385	160	180	50	100	70	240	190	110	285	12	6	M12	M12	24	50	27	8	20	100	46
65X40-200	1	65	40	100	385	160	180	50	100	70	265	212	110	285	13	6	M12	M12	24	50	27	8	20	100	48
65X40-250	2	65	40	100	500	180	225	65	125	95	320	250	110	370	14	6	M12	M12	32	80	35	10	27	100	70
65X40-315	2	65	40	125	500	200	250	65	125	95	345	280	110	370	16	6	M12	M12	32	80	35	10	27	100	80
65X50-160	1	65	50	80	385	132	160	50	100	70	240	190	110	285	11	6	M12	M12	24	50	27	8	20	100	40
80X50-200	1	80	50	100	385	160	200	50	100	70	265	212	110	285	13	6	M12	M12	24	50	27	8	20	100	52
80X50-250	2	80	50	125	500	180	225	65	125	95	320	250	110	370	15	6	M12	M12	32	80	35	10	27	100	72
80X50-315	2	80	50	125	500	225	280	65	125	95	345	280	110	370	18	6	M12	M12	32	80	35	10	27	100	87
80X65-160	1	80	65	100	385	160	180	50	100	70	265	212	110	285	11	6	M12	M12	24	50	27	8	20	100	46
100X65-200	2	100	65	100	500	180	225	65	125	95	320	250	110	370	14	6	M12	M12	32	80	35	10	27	140	70
100X65-250	2	100	65	125	500	200	250	80	160	120	360	280	110	370	16	6	M16	M12	32	80	35	10	27	140	80
100X65-315	3	100	65	125	530	225	280	80	160	120	400	315	110	370	18	6	M16	M12	42	110	45	12	37	140	142
100X80-160	2	100	80	100	500	160	200	65	125	95	280	212	110	370	14	6	M12	M12	32	80	35	10	27	100	68
125X80-400	3	125	80	125	530	280	355	80	160	120	435	355	110	370	20	6	M16	M12	42	110	45	12	37	140	165
125X100-200	2	125	100	125	500	200	280	80	160	120	360	280	110	370	17	6	M16	M12	32	80	35	10	27	140	85
125X100-250	3	125	100	140	530	225	280	80	160	120	400	315	110	370	18	6	M16	M12	42	110	45	12	37	140	126
125X100-315	3	125	100	140	530	250	315	80	160	120	400	315	110	370	19	6	M16	M12	42	110	45	12	37	140	135
125X100-400	3	125	100	140	530	280	355	100	200	150	500	400	110	370	20	6	M20	M12	42	110	45	12	37	140	175
125X100-500	4	125	100	160	670	355	450	100	200	150	550	450	140	500	25	10	M20	M16	48	110	51.5	14	42.5	180	338
150X125-250	3	150	125	140	530	250	355	80	160	120	400	315	110	370	19	6	M16	M12	42	110	45	12	37	140	140
150X125-315	3	150	125	140	530	280	355	100	200	150	500	400	110	370	20	6	M20	M12	42	110	45	12	37	140	150
150X125-400	3	150	125	140	530	315	400	100	200	150	500	400	110	370	21	6	M20	M12	42	110	45	12	37	140	186
150X125-500	4	150	125	160	670	355	450	100	200	150	550	450	140	500	25	10	M20	M16	48	110	51.5	14	42.5	180	350
200X150-315	4	200	150	160	670	315	400	100	200	150	550	450	140	500	25	10	M20	M16	48	110	51.5	14	42.5	180	222
200X150-400	4	200	150	160	670	315	450	100	200	150	550	450	140	500	25	10	M20	M16	48	110	51.5	14	42.5	180	300
200X150-500	4	200	150	160	670	400	500	100	200	150	550	450	140	500	25	10	M20	M16	48	110	51.5	14	42.5	180	382
250X200-200	4	250	200	180	670	315	450	100	200	150	550	450	140	500	22	10	M20	M16	48	110	51.5	14	42.5	180	345
250X200-250	5	250	200	180	885	315	450	100	200	150	550	450	180	670	25	12	M24	M16	65	140	69	18	58	250	490
250X200-315	4	250	200	180	670	315	450	100	200	150	550	450	140	500	25	10	M20	M16	48	110	51.5	14	42.5	180	277
250X200-400	4	250	200	180	670	355	500	100	200	150	550	450	140	500	25	10	M20	M16	48	110	51.5	14	42.5	180	340
250X200-500	5	250	200	225	885	400	580	125	315	250	760	630	180	670	28</										

**PCC Series** Chemical Process Pump (ISO5199/2858, EN 25199/22858 Std)

Performance Chart (50Hz)

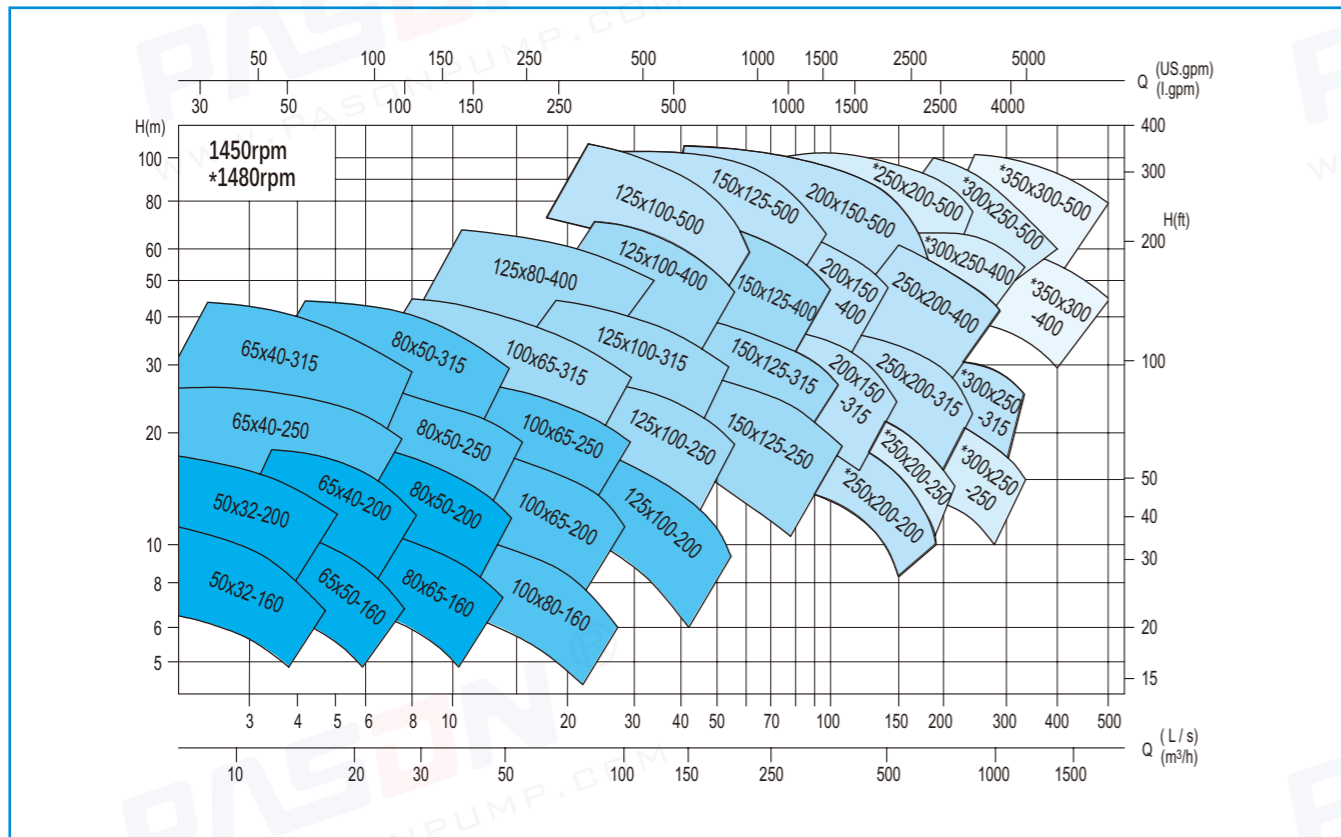

**PCC Series** Chemical Process Pump (ISO5199/2858, EN 25199/22858 Std)

Performance Chart (60Hz)

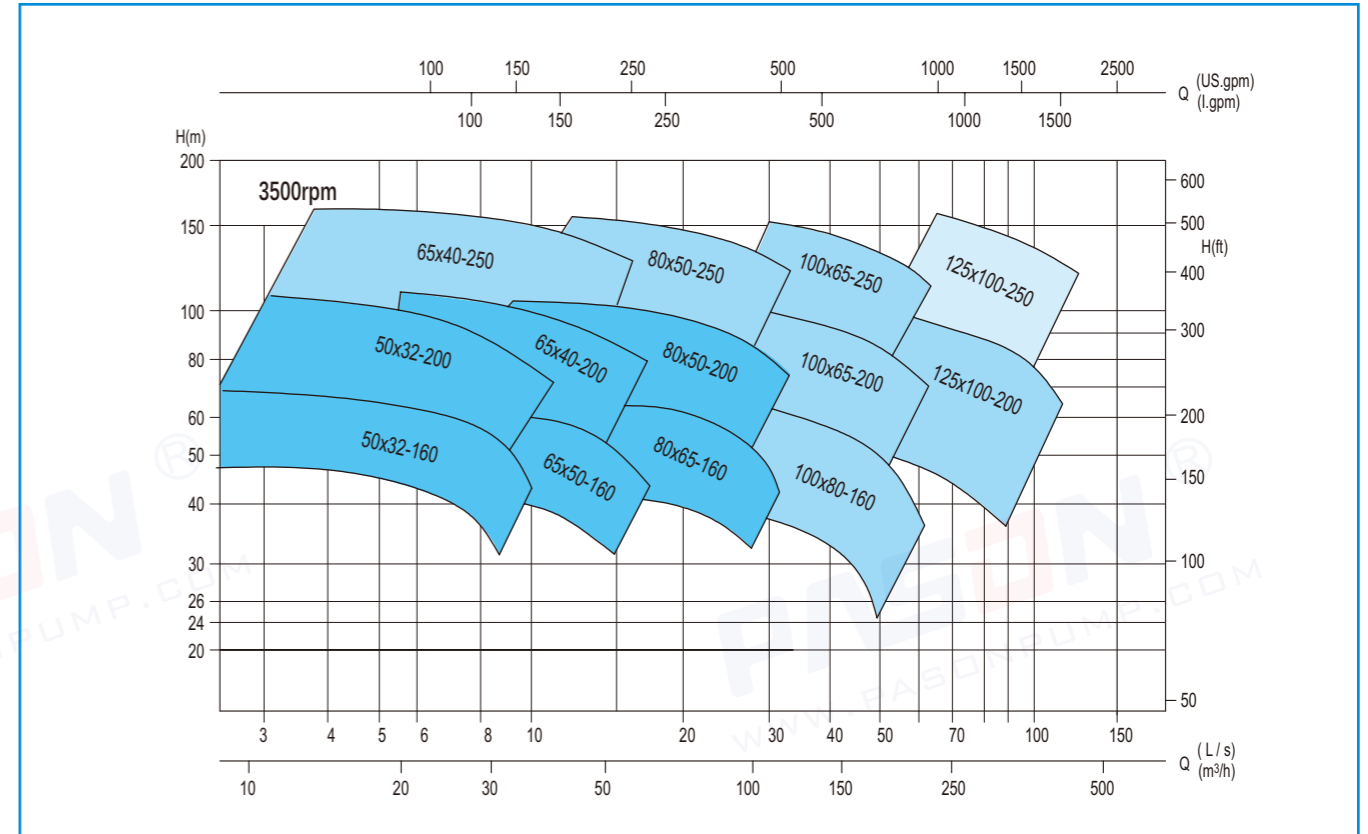
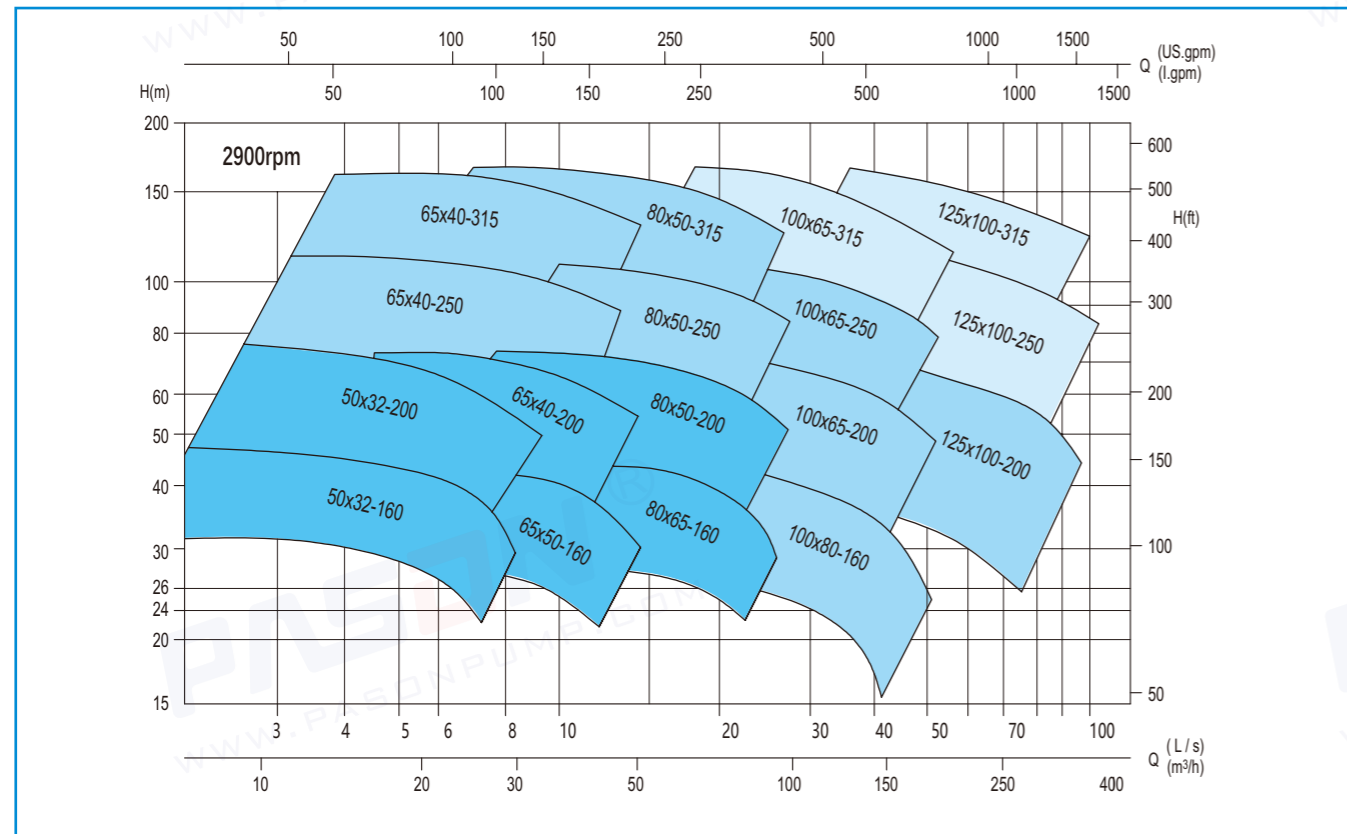
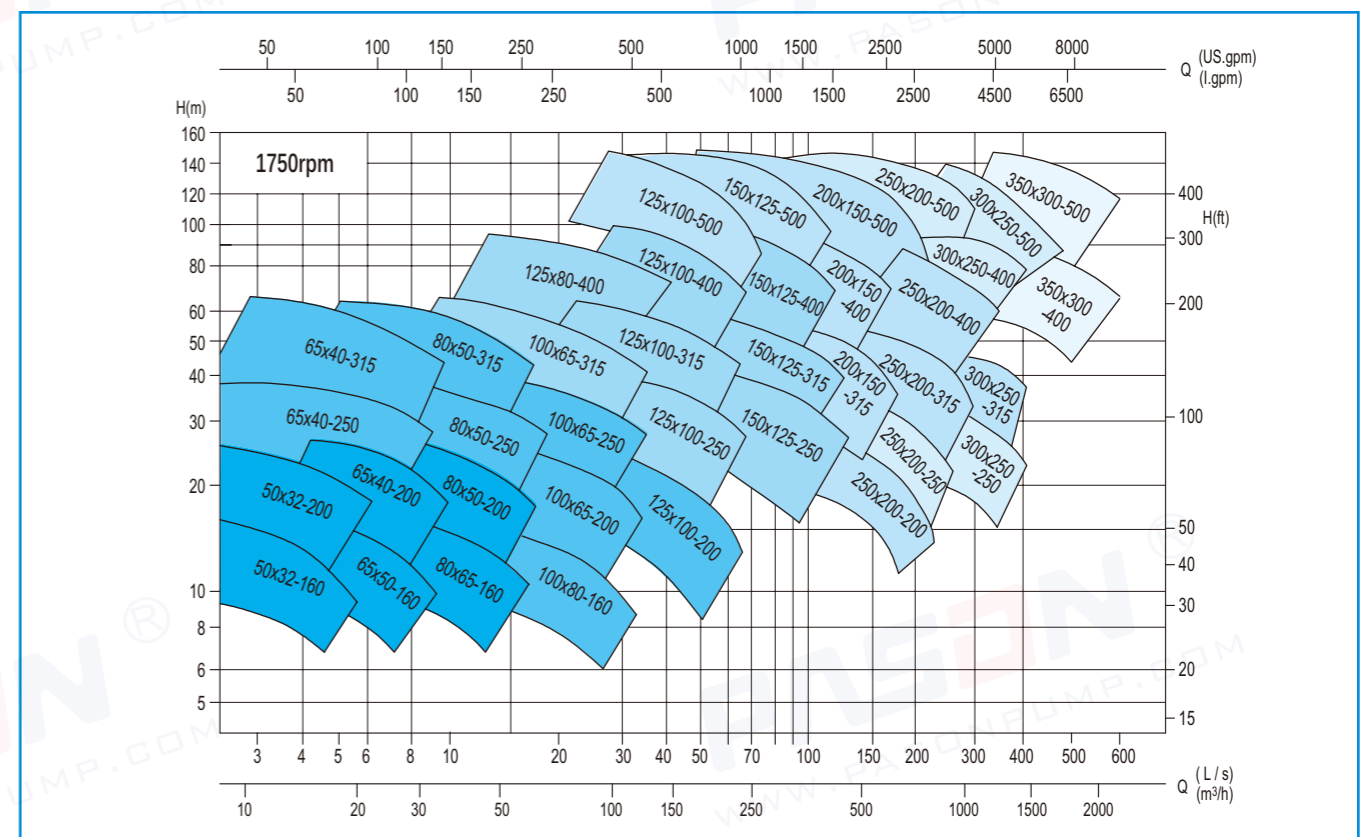

# PPS Series Pulp Pump

## Design & Features

PPS design is in accordance with international standards of ISO2858/5199. PPS pumps with Semi open impeller and front/back wear plate, And it can transfer a certain amount of gas medium, with a good meet for pulp and paper making process requirements, ensures a robust, long lasting, high performing product consumers have come to depend on from Preeminence.

PPS type pulp pump digest and absorbs the advantages of foreign advanced products, summarizes the research experience of our company engaged in paper industry for many years and cooperated with the institute technical research. it is a successfully developed upgrading products.

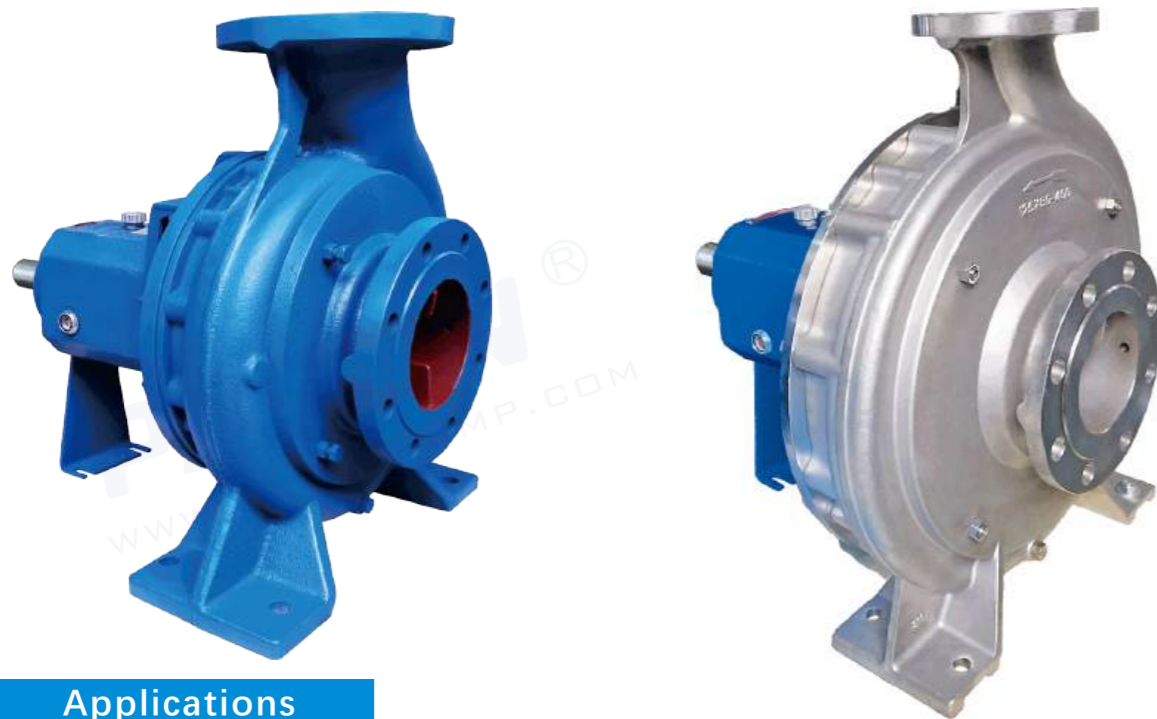

## Applications



Chemical and Petrochemical Industry



Oil refining plants



Paper making industry



Sugar Industry



Waste Water Treatment



Pharmaceutical Food Industry

## Model Designation(Examples): PPS 125X100-315

PPS

Series

125

Suction(mm)

100

Discharge(mm)

315

Impeller Nominal Diameter(mm)

Design	Performance and dimension as per ISO 2858/5199
Structure	Horizontal ,End suction, Single suction,Volute casing
DN(mm)	Suction size: 50~350, Discharge size: 32~300
Flange	DIN 2501,PN16

## Design

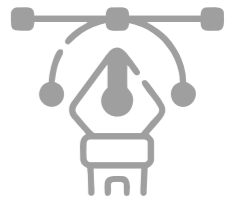

Pump parts	Material
Casing / Impeller	Cast iron/Stainless steel
Shaft	Stainless steel
Shaft seal	Mechanical Seal
Bearing lubrication	Oil lubrication
Bearing Brand	Heavy Duty NTN

## Material



Speed	Up to 3600rpm
Flow Rate(Q)	Up to 1900m³/h-1450rpm 2430m³/h-1750rpm
Head(H)	Up to 160m
Pressure	PN16 as standard
Liquid Temperature	Up to 120 °C

## Operating Data

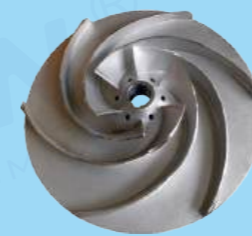

semi-open impeller

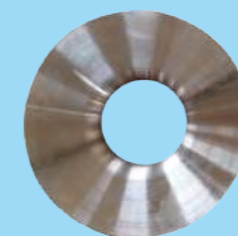

wear plate



## PPS Series Pulp Pump

### Impeller

Optimized Hydraulic design with semi-open impeller diameter up to 547mm, PPS pumps have wider performance coverage EN 25199/22858

### Heavy Duty Tough Bearings

Cylindrical roller bearing at the impeller end, two angular contact ball bearing (back to back arrangement) at the drive end. Design bearing life up to 25000 hours. Long service life

### Sturdy Shaft

Ensures minimum shaft deflection and low mechanical vibration

### Wear Plate

Wear plate according to impeller design To protect the pump casing

### Shaft sealing

Single as standard, Double mechanical seal, Cartridge mechanical seal, Gland packing are available

Single mechanical seal for stock conveyance with sealing and rinsing water Capital investment and operating cost savings

### Application

The PPS pulp pump is suitable for handling water or similar liquids mainly used in the following.

- Chemical and Petrochemical Industry
- Oil refining plants
- Pulp and Paper making industry
- Waste water treatment
- Pharmaceutical
- Food Industry(e.g.sugar)

### Axial Force Balance

The axial force are mostly balance by the front/rear wear plate and balanceing holes in impeller design, The residual axial force are balanced by the back to back arranged contact ball bearings at the drive end.

### Flange

Flange dimensions comply to ISO 7005-1:1992 PN16 Mpa as standard, other flange(including ANSI flange) are also available by request

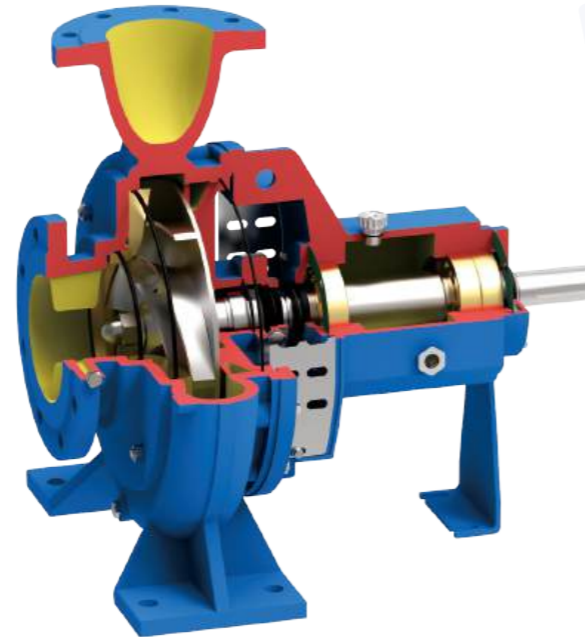

### Section Drawing

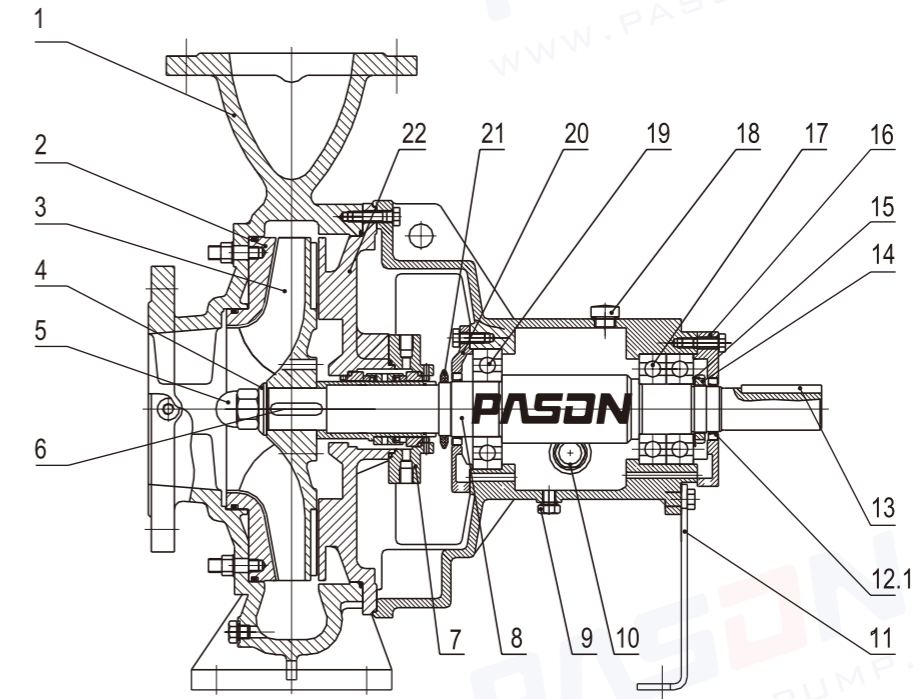

### Standard

### Optional

#### Single Seal

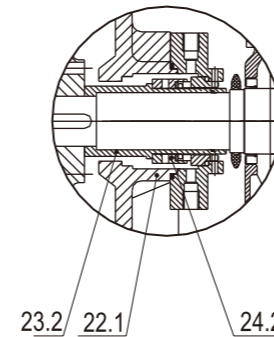

#### Double Seal

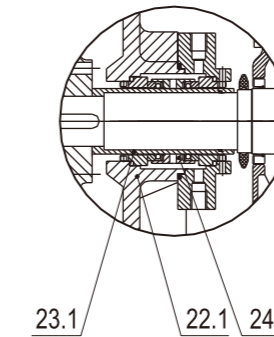

#### Cartridge Seal

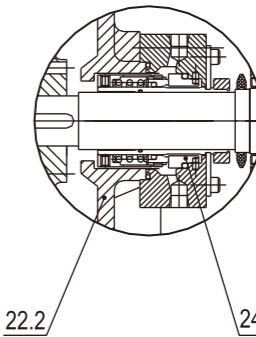

#### Dynamic Seal

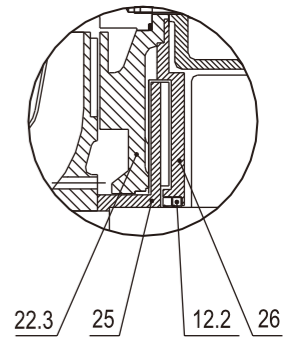

### Operating Data -50Hz

Pump sizes	32mm to 350mm	
Flow	up to	2000 m³/h
Head	up to	160 m
Temperature	up to	175°C
Speed	up to	3600 rpm
Pressure	up to	24 Bar

S/N	Part Name
1	Pump Casing
2	Casing wear plate
3	Impeller
4	Impeller Washer
5	Impeller nut
6	Impeller key
7	Seal Cover
8	Pump Shaft
9	Drain plug

S/N	Part Name
10	Oil Indicator
11	Support Foot
12.1/12.2	Oil Seal
13	Key(coupling)
14	Round Nut
15	Tab washer
16	Bearing Cover
17	Angular contact ball bearing
18	Oil hole cover

S/N	Part Name
19	Cylindrical roller bearing
20	Bearing Cover
21	Slinger
22.1/22.2/22.3	Casing Cover
23.1/23.2	Shaft Sleeve
24.1/24.2/24.3	Mechanical seal
25	Vice impeller
26	Seal plate

PPS Series Pulp Pump

Intalling Dimension

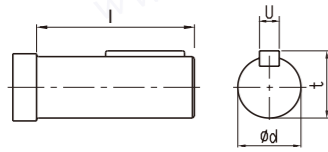

Drive Shaft Dimensions

Shaft No	ød	l	u	t
1	24	50	8	27
2	32	80	10	35
3	42	110	12	45
4	48	110	14	51.5
5	65	140	18	69
6	75	170	20	79.5

Flange Connecting Dimension (ISO 2084,PN16)

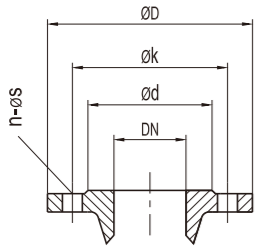

DN	ød	øk	ØD	n	øS
32	76	100	140	4	18
40	84	110	150	4	18
50	99	125	165	4	18
65	118	145	185	4	18
80	132	160	200	8	18
100	156	180	220	8	18
125	184	210	250	8	18
150	211	240	285	8	22
200	266	295	340	12	22
250	320	355	405	12	26
300	370	410	460	12	26
350	429	470	520	16	26

Notes: 1. Optional Flange: AS2129-1982, ANSI 16.1-1975, JISB 2210-1984

Service Connections

Pump Model	A	B	D	S
	Casing Drain	Housing Drain	Gauge Drain	Gauge Drain
50X32-160	1/4	3/8	1/4	1/4
50X32-200	1/4	3/8	1/4	1/4
65X40-200	1/4	3/8	1/4	1/4
65X40-250	1/4	3/8	1/4	1/4
65X40-315	1/4	3/8	1/4	1/4
65X50-160	1/4	3/8	1/4	1/4
80X50-200	1/4	3/8	1/4	1/4
80X50-250	1/4	3/8	1/4	1/4
80X50-315	1/4	3/8	1/4	1/4
80X65-160	1/4	3/8	1/4	1/4
100X65-200	1/4	3/8	1/4	1/4
100X65-250	1/4	3/8	1/4	1/4
100X65-315	1/4	3/8	1/4	1/4
100X80-400	1/4	3/8	1/4	1/4
125X100-200	1/4	3/8	1/4	1/4
125X100-250	1/4	3/8	1/4	1/4
125X100-315	1/4	3/8	1/4	1/4
125X100-400	1/4	3/8	1/4	1/4

Pump Model	A	B	D	S
	Casing Drain	Housing Drain	Gauge Drain	Gauge Drain
125X100-500	3/8	3/8	3/8	3/8
150X125-250	1/4	3/8	1/4	1/4
150X125-315	1/4	3/8	1/4	1/4
150X125-400	1/4	3/8	1/4	1/4
150X125-500	3/8	3/8	3/8	3/8
200X150-315	3/8	3/8	3/8	3/8
200X150-400	3/8	3/8	3/8	3/8
200X150-500	3/8	3/8	3/8	1/2
250X200-200	3/8	3/8	3/8	3/8
250X200-250	1/2	3/8	1/2	1/2
250X200-315	3/8	3/8	3/8	3/8
250X200-400	3/8	3/8	3/8	3/8
250X200-500	1/2	3/8	1/2	1/2
300X250-250	1/2	3/8	1/2	1/2
300X250-315	1/2	1/2	1/2	1/2
300X250-400	1/2	3/8	1/2	1/2
300X250-500	1/2	3/8	1/2	1/2
350X300-400	1/2	1/2	1/2	1/2
350X300-500	1/2	1/2	1/2	1/2

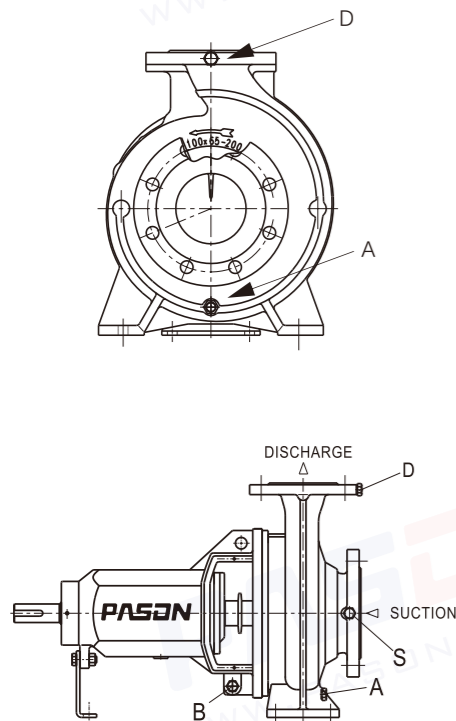

Dimensions-Bare Shaft Pump

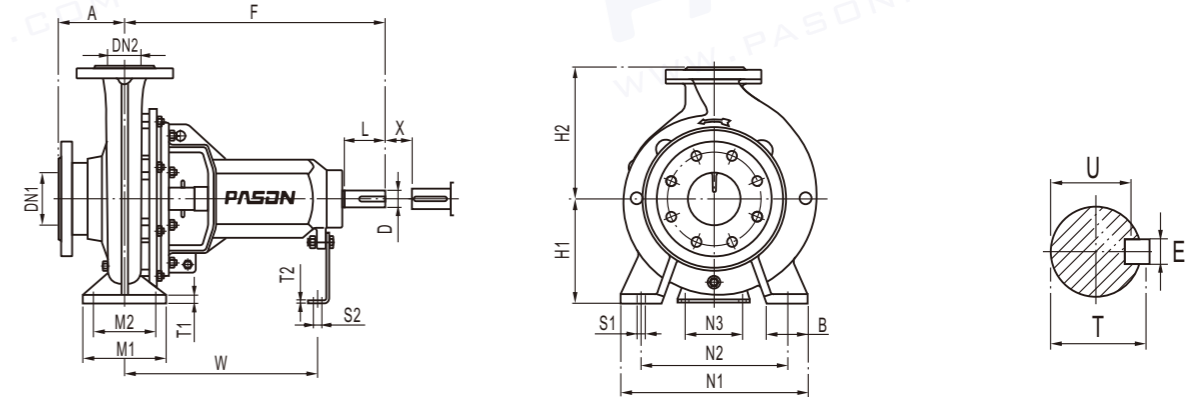

Pump Model	Shaft No.	Flange Size		Pump Dimensions				Foot Dimensions						Bolt Holes		Shaft End					Spacer X ≥	Net. Weight			
		DN1	DN2	A	F	H1	H2	B	M1	M2	N1	N2	N3	W	T1	T2	S1	S2	D	L			T	E	U
50X32-160	1	50	32	80	385	132	160	50	100	70	240	190	110	285	12	6	M12	M12	24	50	27	8	20	100	50
50X32-200	1	50	32	80	385	160	180	50	100	70	240	190	110	285	12	6	M12	M12	24	50	27	8	20	100	55
65X40-200	1	65	40	100	385	160	180	50	100	70	265	212	110	285	13	6	M12	M12	24	50	27	8	20	100	52
65X40-250	2	65	40	100	500	180	225	65	125	95	320	250	110	370	14	6	M12	M12	32	80	35	10	27	100	85
65X40-315	2	65	40	125	500	200	250	65	125	95	345	280	110	370	16	6	M12	M12	32	80	35	10	27	100	108
65X50-160	1	65	50	80	385	132	160	50	100	70	240	190	110	285	11	6	M12	M12	24	50	27	8	20	100	40
80X50-200	1	80	50	100	385	160	200	50	100	70	265	212	110	285	13	6	M12	M12	24	50	27	8	20	100	53
80X50-250	2	80	50	125	500	180	225	65	125	95	320	250	110	370	15	6	M12	M12	32	80	35	10	27	100	90
80X50-315	2	80	50	125	500	225	280	65	125	95	345	280	110	370	18	6	M12	M12	32	80	35	10	27	100	108
80X65-160	1	80	65	100	385	160	180	50	100	70	265	212	110	285	11	6	M12	M12	24	50	27	8	20	100	46
100X65-200	2	100	65	100	500	180	225	65	125	95	320	250	110	370	14	6	M12	M12	32	80	35	10	27	140	70
100X65-250	2	100	65	125	500	200	250	80	160	120	360	280	110	370	16	6	M16	M12	32	80	35	10	27	140	98
100X65-315	3	100	65	125	530	225	280	80	160	120	400	315	110	370	18	6	M16	M12	42	110	45	12	37	140	142
100X80-160	2	100	80	100	500	160	200	65	125	95	280	212	110	370	14	6	M12	M12	32	80	35	10	27	100	68
125X80-400	3	125	80	125	530	280	355	80	160	120	435	355	110	370	20	6	M16	M12	42	110	45	12	37	140	175
125X100-200	2	125	100	125	500	200	280	80	160	120	360	280	110	370	17	6	M16	M12	32	80	35	10	27	140	89
125X100-250	3	125	100	140	530	225	280	80	160	120	400	315	110	370	18	6	M16	M12	42	110	45	12	37	140	143
125X100-315	3	125	100	140	530	250	315	80	160	120	400	315	110	370	19	6	M16	M12	42	110	45	12	37	140	151
125X100-400	3	125	100	140	530	280	355	100	200	150	500	400	110	370	20	6	M20	M12	42	110	45	12	37	140	200
125X100-500	4	125	100	160	670	355	450	100	200	150	550	450	140	500	25	10	M20	M16	48	110	51.5	14	42.5	180	338
150X125-250	3	150	125	140	530	250	355	80	160	120	400	315	110	370	19	6	M16	M12	42	110	45	12	37	140	140
150X125-315	3	150	125	140	530	280	355	100	200	150	500	400	110	370	20	6	M20	M12	42	110	45	12	37	140	165
150X125-400	3	150	125	140	530	315	400	100	200	150	500	400	110	370	21	6	M20	M12	42	110	45	12	37	140	201
150X125-500	4	150	125	160	670	355	450	100	200	150	550	450	140	500	25	10	M20	M16	48	110	51.5	14	42.5	180	350
200X150-315	4	200	150	160	670	315	400	100	200	150	550	450	140	500	25	10	M20	M16	48	110	51.5	14	42.5	180	248
200X150-400	4	200	150	160	670	315	450	100	200	150	550	450	140	500	25	10	M20	M16	48	110	51.5	14	42.5	180	325
200X150-500	4	200	150	160	670	400	500	100	200	150	550	450	140	500	25	10	M20	M16	48	110	51.5	14	42.5	180	382
250X200-200	4	250	200	180	670	315	450	100	200	150	550	450	140	500	22	10	M20	M16	48	110	51.5	14	42.5	180	345
250X200-250	5	250	200	180	885	315	450	100	200	150	550	450	180	670	25	12	M24	M16	65	140	69	18	58	250	490
250X200-315	4	250	200	180	670	315	450	100	200	150	550	450	140	500	25	10	M20	M16	48	110	51.5	14	42.5	180	281
250X200-400	4	250	200	180	670	355	500	100	200	150	550	450	140	500	25	10	M20	M16	48	110	51.5	14	42.5	180	340
250X200-500	5	250	200	225	885	400	580	150	315	250	760	630	180	670	28	12	M24	M16	65	140	69	18	58	250	600
300X250-250	5	300	250	225	885	355	560	125																	

PPS Series Pulp Pump

Performance Chart (50Hz)

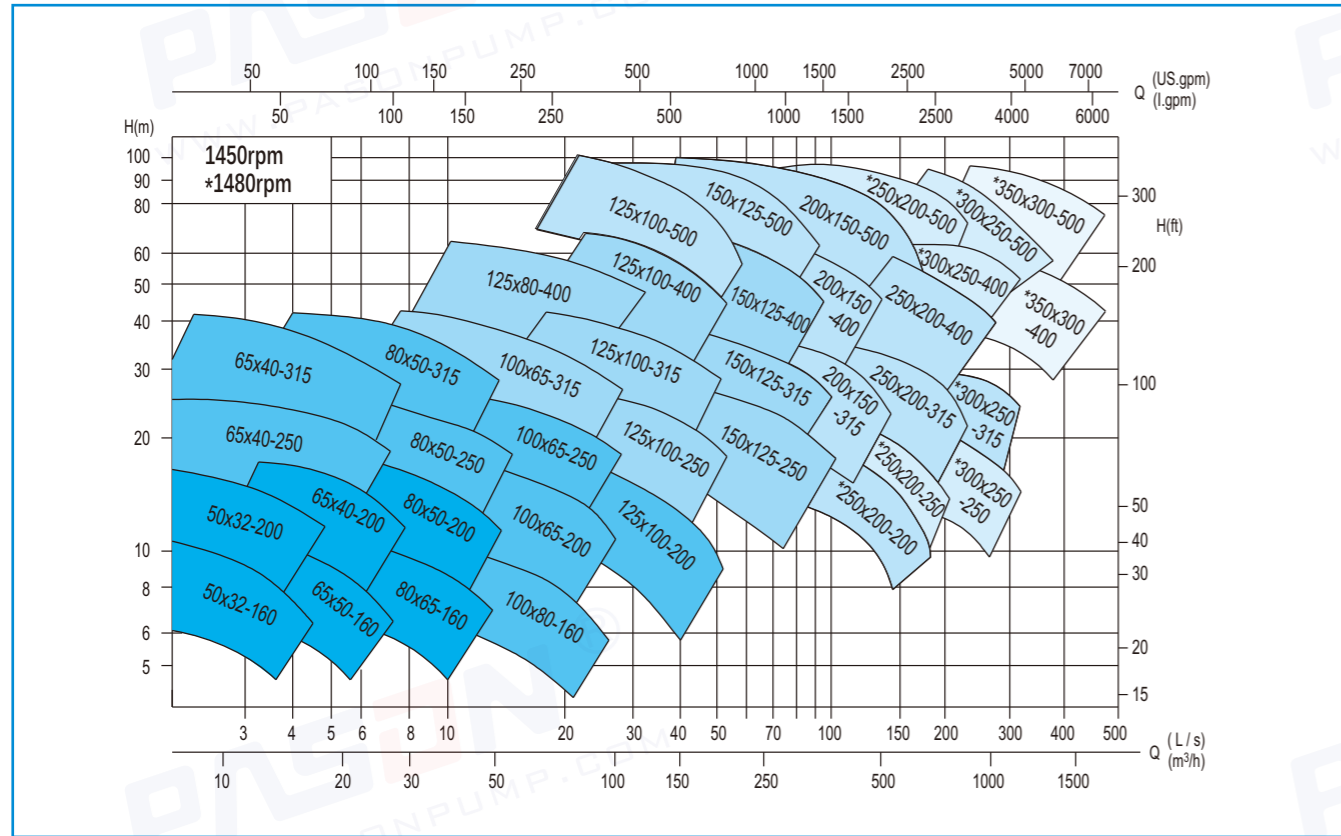

PPS Series Pulp Pump

Performance Chart (60Hz)

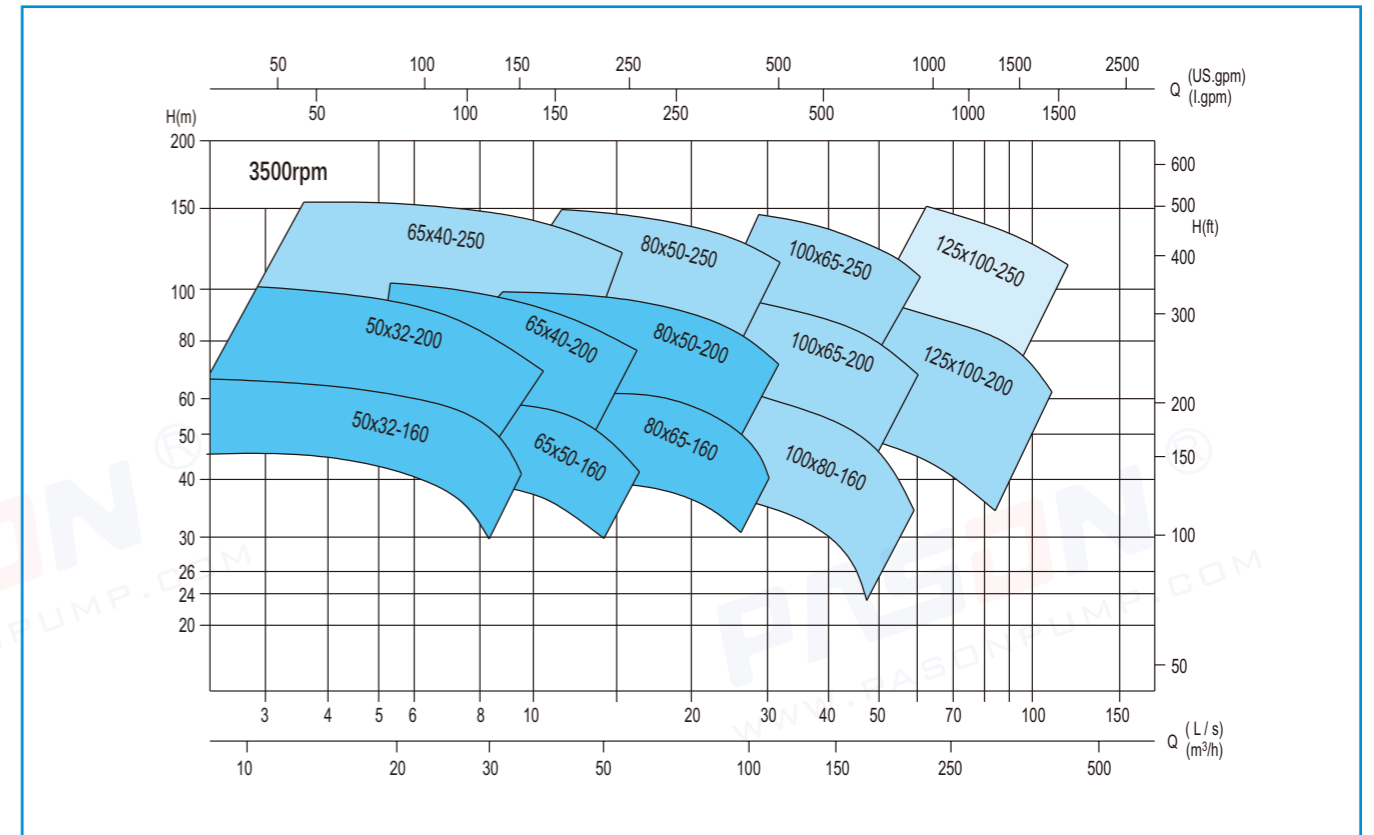
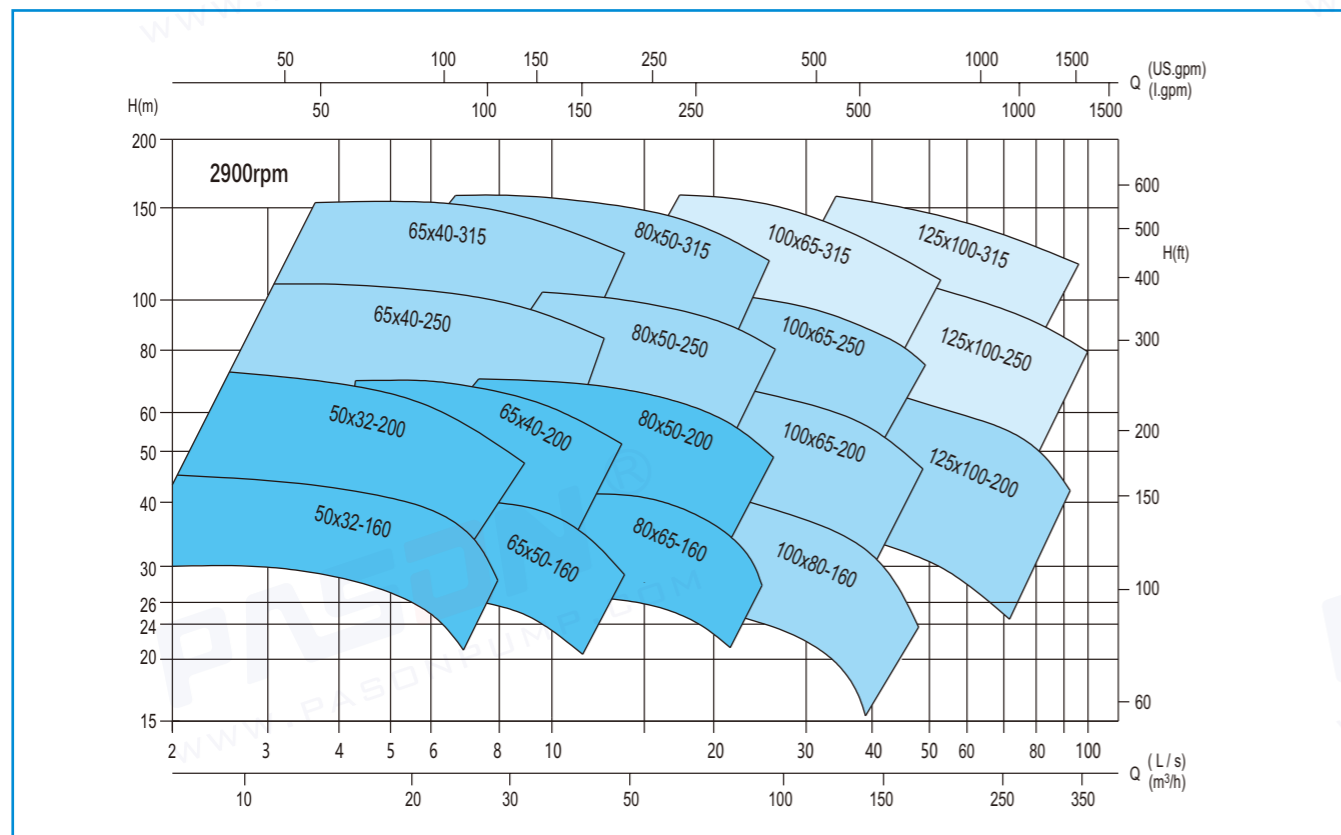
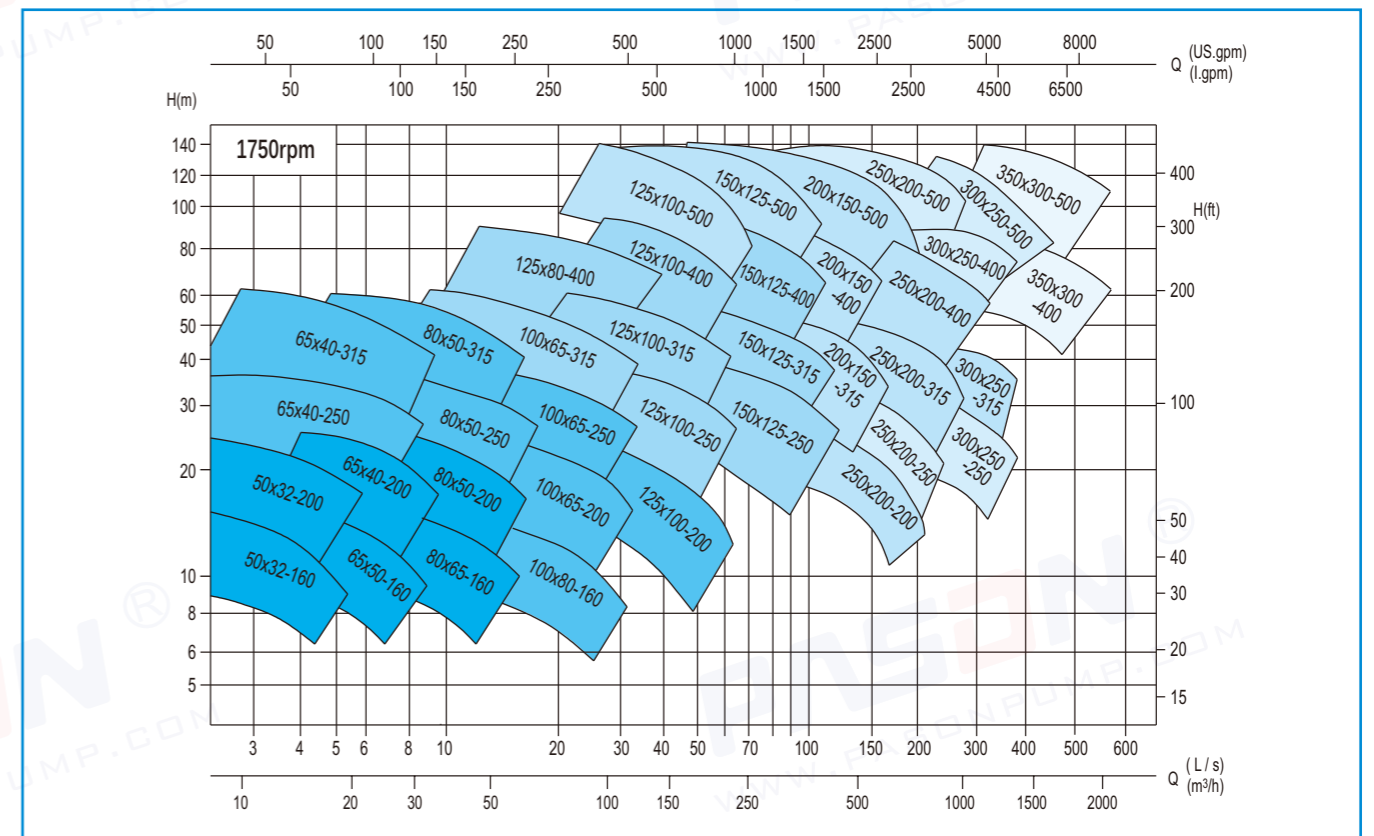

# PT Series

## Self Priming Trash Pump From 2 inch to 12 inch

### Design Features

PT Pumps presents a range of Self-Priming Centrifugal. These pumps are economical & offer trouble-free operation in handling solids laden liquids and slurries. Pump features a large volume design which allows them to re-prime automatically in a completely open system without the need of suction or discharge check valves. And this is workable with the pump only partially filled with liquid and completely dry suction line. Pump can handle up to 3" (76.2mm) spherical solids, depending on pump models. In case pump shafts or bearings need service, the entire rotating assembly can be removed without disturbing pump casing or pipelines.

### Key Advantages

- Superior Solid Handling
- Self Priming
- Easy Maintenance

### Material Options

- Cast Iron, Ductile Cast Iron, Bronze, SUS304, SUS316,

### Available Discharge Sizes

- 2", 3", 4", 6", 8", 10", 12"

### Impeller Options

- Two-vane, ductile iron, semi-open solids-handling impeller handles up to 75 mm (3") diameter solids, depending on pump model. Pump out vanes on the impeller shroud reduce foreign material buildup behind the impeller and reduce pressure on seal and bearings.



### Cartridge Seal

- Available in Tc/Tc/Viton mechanical seal to handle abrasive liquid and sewage, Industrial waste etc.. Custom designed seal to handle corrosive chemical like Keton, Xylene, Tolulene

### Trash Design

- Trash cover for easy maintenance without disturbing pipeline

### Dual Bearing Protection

- An atmospheric barrier along with two lip seals provide additional protection of the pump bearings. This unique design also allows for quick and easy external monitoring of the bearing cavity (not available on 2" models).

### Removable Rotating Assembly

- The entire rotating assembly can be removed without disturbing the pump volute or piping. Pusher bolt holes are provided to assist with removal. This allows for quick and easy installation of a spare rotating assembly, resulting in less downtime.

### Drive Options

- Can be coupled with standard NEMA & IEC motors. No special motor required. Also can be coupled with diesel engine.

### Coupling Options

- Direct Coupled
- Belt - Pulley Driven

### Model Code

PT-4

Inlet and outlet: 4" (φ100mm)

Self-priming Trash pump



### Section Drawing

PT-2,3,4,6,8

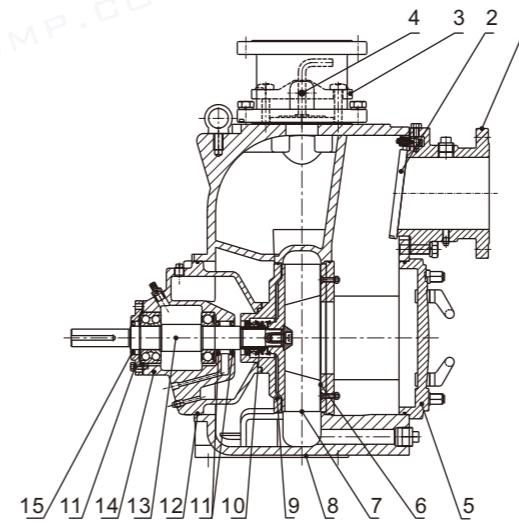

PT-10

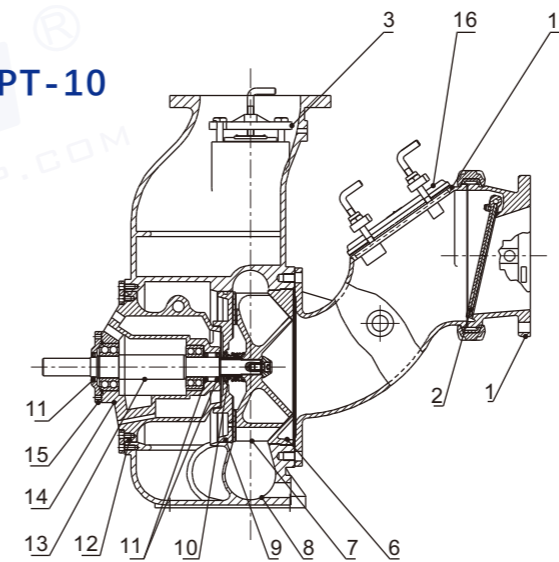

NO	Parts name	Material
1	Suction Inlet	GG 25
2	Flap Valve	NBR+Carbon steel
3	Infusion cover	GG 25
4	Discharge Outlet	GG 25
5	End Cover	GG 25
6	Wear Plate	ASTM 1045
7	Impeller	GGG 50 SS304/SS316
8	Volute	GG 25
9	Seal Plate	GG 25
10	Cartridge Seal	TC/TC/Viton
11	Lip Seal	NBR
12	O-Ring	NBR
13	Shaft	ASTM 420
14	Bearing Body	GG 25
15	Bearing Cover	GG 20
16	Inlet Cover	GG 25
17	Inlet	GG 20

### Performance Table

Model	Speed (rpm)	Max Q (m³/h)	Max H (m)	Suction head (m)	Power (HP)	Max Solids (mm)
PT-2	1150~2900	46	35	7.3~7.6	1~10	44.45
PT-3	650~2150	110	35	1.5~7.6	1~20	63.5
PT-4	650~1950	160	36	1.5~7.6	1~30	76.2
PT-6	650~1550	350	32	2.4~7.6	2~40	76.2
PT-8	650~1450	600	36.5	2.7~7.0	7.5~75	76.2
PT-10	650~1450	750	39	2.7~6.7	10~120	76.2
PT-12	650~1150	1400	32	2.5~7.0	20~147	55
PT-12V	900~1200	1250	30	5.0~7.0	60~147	70

**PT Series Self Priming Trash Pump**

**Design Features/Advantages**

**Casing**

- Full line of corrosive resistant materials
- \*self venting, centerline mounted discharge flange
- \* Various connection options: Threaded, Flanged
- \*Increased casing thickness for extended casing life

**Flapper Valve**

- \*Automatically closes once pump is stopped to avoid losing priming

**Removable Adjustable Cover Plate**

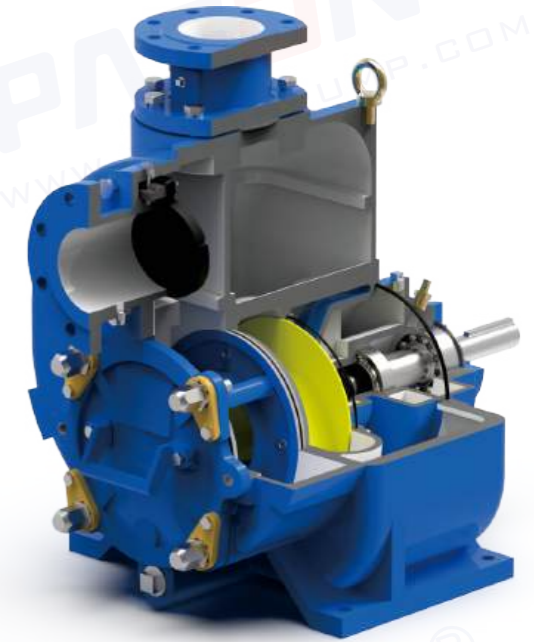
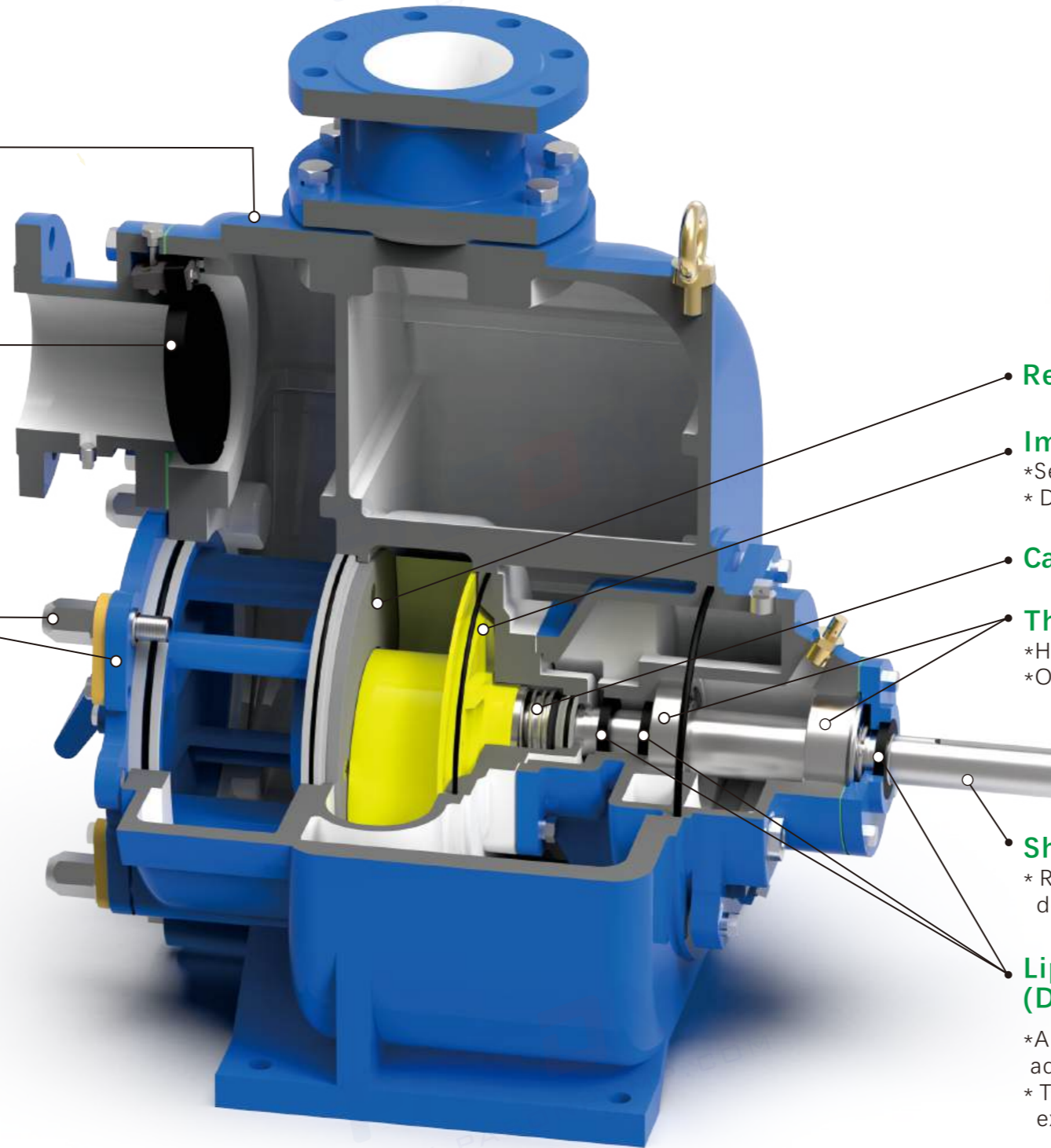

**Replaceable Wear Plate**

**Impeller**

- \*Semi-open impeller
- \* Designed to pump solids up to 3"(76mm)

**Cartridge Mechanical Seal TC/TC/Viton**

**Thrust Bearing**

- \*Heavy duty double row standard
- \*Optional duplex angular contact thrust bearing

**Shaft**

- \* Rigid heavy duty design for minimum shaft deflection at seal area and increased reliability

**Lip seal (Dual bearing protection)**

- \*An atmospheric barrier along with two lip seal provide additional protection of the pump bearings,
- \* This unique design also allows for quick and easy external monitoring of the bearing cavity

**PT Series Self Priming Trash Pump**

**PT 2~8 Outline Dimensions (Unit: mm)**

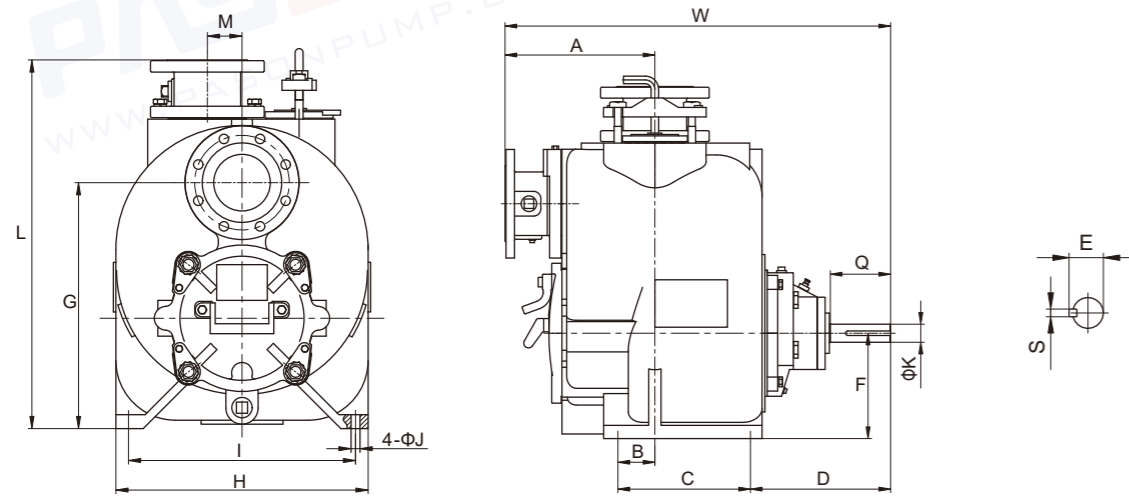

Pump Model	Pump Dimension					Foot Dimension				Shaft Dimension				Net Wight (kgs)			
	L	G	F	M	W	A	J	I	H	B	C	D	K		Q	S	E
PT-2	526.5	318	151.5	69.9	621.8	242	14	281	308	61	170.2	270.6	38.1	101.6	9.6	42.3	112
PT-3	687.5	431.8	190.5	69.9	735.3	295.5	18	393.7	431.8	76.2	228.6	287.4	38.1	101.9	9.6	42.3	198
PT-4	742.5	495.3	222.3	69.8	813.1	316	18	457.2	508	77.9	279.4	295.6	38.1	127.1	9.6	42.3	315
PT-6	896.5	568.2	257.2	69.8	899.9	403	18	527	577.8	77.7	279.4	295.3	38.1	127	9.6	42.3	478
PT-8	1068.5	723.9	330.2	-	1025	411.7	23	635	705	101.6	304.8	410.1	44.4	171.4	9.6	48.7	720

**PT-10 Outline Dimensions (Unit: mm)**

**Net Weight: 700 kgs**

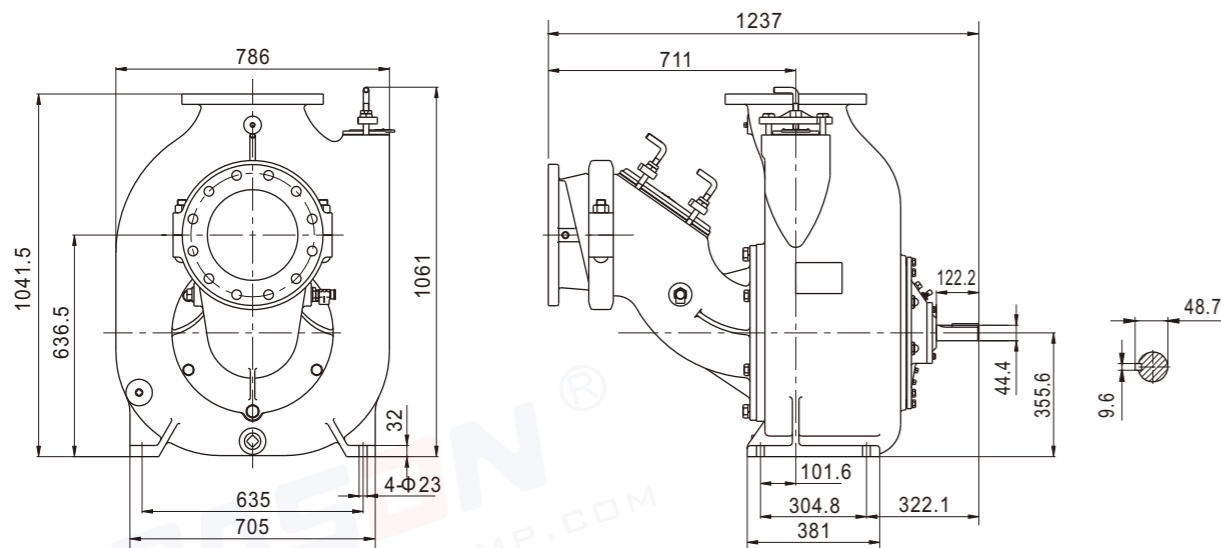

**PT-12 & 12V Outline Dimensions, pls contact us**

**Performance Charts**

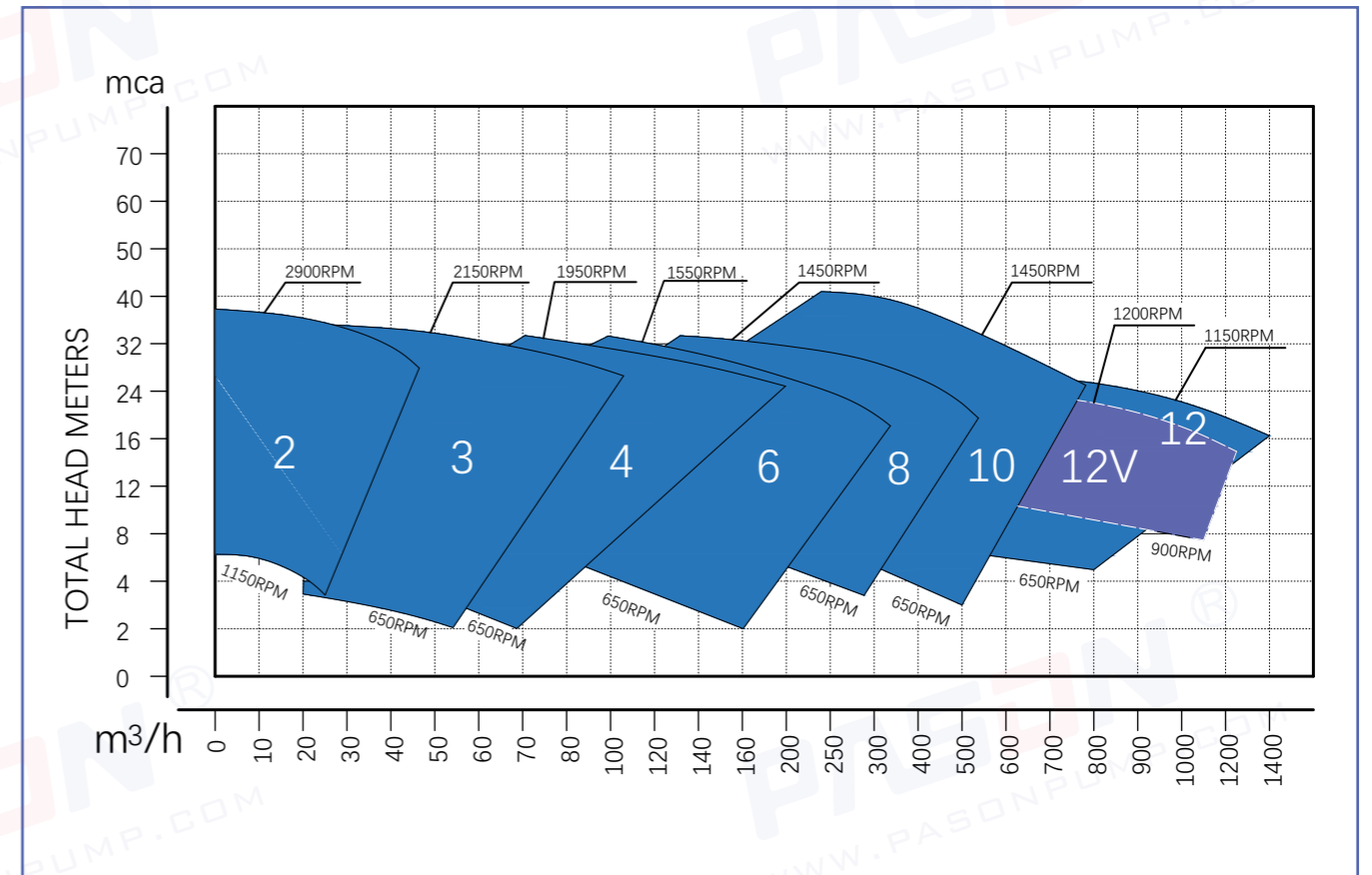

**Seni open-Silent-Type trailer**

**Open-type Trailer**

**Silent-Type trailer**



# PPW Series 3-Vane impeller

## Non-Clogging Process Pump Max solids 100mm

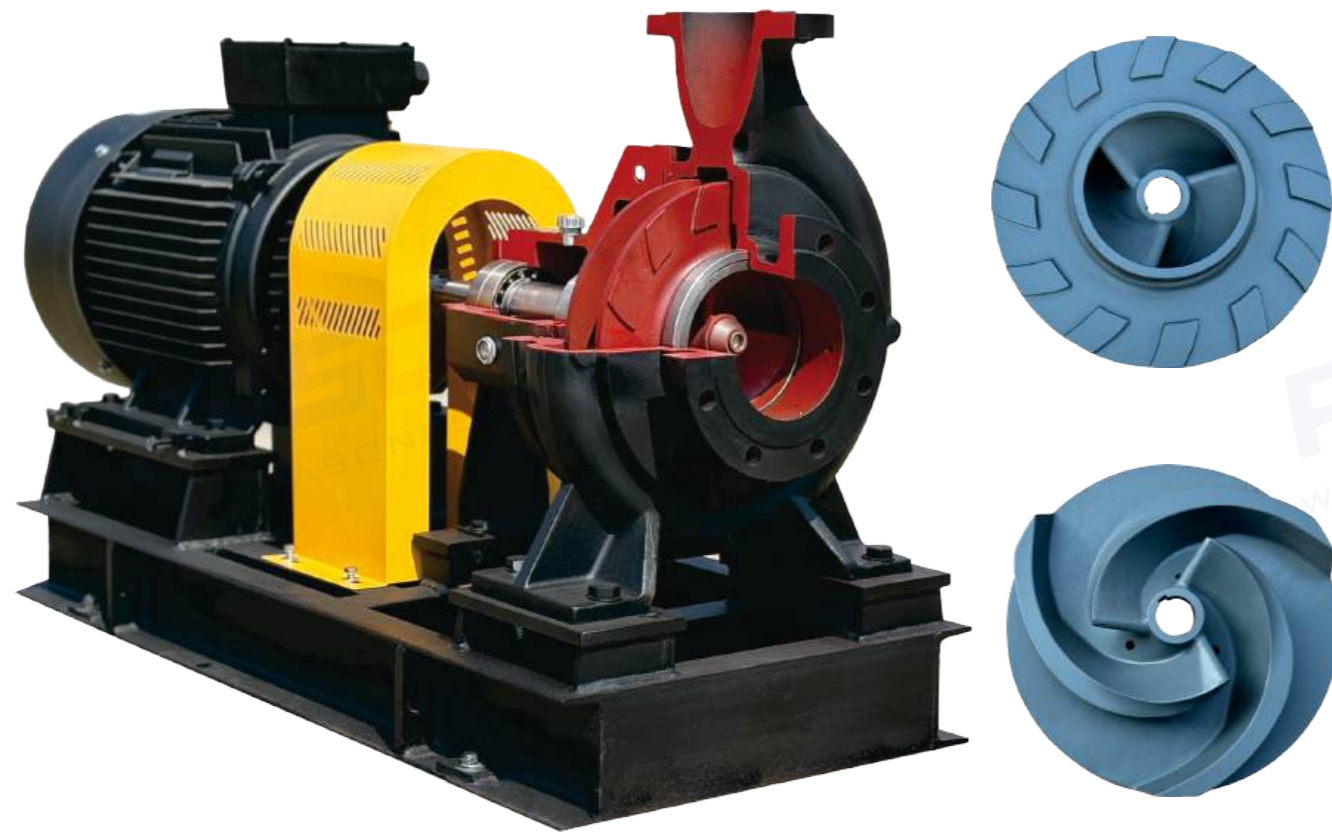

### Design & Features

Horizontal, Radially split volute casing pump in back pull-out design, with impeller adapted to meet application requirements, single-flow, single-stage.

### Fields of Application

The impeller is with 3 vanes, with this special vane design, it covers bigger high efficiency range, stronger capability of sewage passing. If used for fiber, the max passing sizes even up to 5 times bigger than pump outlet. If used for fluid with Solids, the max size can up to half of the pump outlet.

This pump is used in the chemical and process engineering industries, paper and pulp industries, sugar, food and beverages industries, in flue gas desulphurisation and coal upgrading and in the treatment of industrial effluents.

### Operating Data

Discharge flange sizes : 125~300 mm  
 Capacity Q: up to 1700 m³/h  
 Head H: up to 50m  
 Max solids : 100 mm  
 Operating pressure P: up to 16bar  
 Operating temperature t: -15°C ~ +104°C

\* If the liquid Temperature over 80°C degrees, please indicate



### Main applications

Mining industry Sugar Industry	Industrial Waste Water Treatment systems	Paper industry Pulp industry
Chemical and Petrochemical Industry	Oil refining plants	Pharmaceutical Food Industry Beverage industry

### Model Designation(Examples): PPW-K 300X250-350

<b>PPW</b>	<b>K</b>	<b>300</b>	<b>250</b>	<b>350</b>
Type series	Impeller types: K= Close impeller O=Open impeller	Suction(mm)	Discharge(mm)	Impeller Nominal Diameter(mm)

## PPW Series Non-Clogging Process Pump

### Pump data (Performance to fluid clean water)

Pump Model	Suction	Discharge	Speed	Capacity		Head	Eff	Npshr	Max solids	Motor Model	Motor power
	mm	mm	rpm	m³/h	l/s	m	%	m	mm		kW
150X125-250	150	125	1450	250	69.4	20	73	3.2	50	180L-4	22
150X125-315	150	125	1450	250	69.4	30	76	3.2	45	225M-4	45
150X125-400	150	125	1450	250	69.4	40	66	3.5	35	250M-4	55
200X150-315	200	150	1450	400	111.1	30	71	3.5	50	250M-4	55
200X150-400	200	150	1450	400	111.1	40	70	3.5	35	280S-4	75
250X200-200	250	200	1450	600	166.7	15	79	3.8	80	225M-4	45
250X200-250	250	200	1450	600	166.7	20	83	3.8	76	250M-4	55
250X200-315	250	200	1450	700	194.4	22	83	3.8	76	280S-4	75
250X200-400	250	200	1450	600	166.7	35	70	4.0	65	315S-4	110
300X250-250	300	250	1450	900	250	20	80	4.1	90	280S-4	75
300X250-315	300	250	1450	850	236.1	25	73	4.1	90	315S-4	110
300X250-350	300	250	1450	800	222.2	32	76	4.1	90	315S-4	110
300X250-400	300	250	1450	800	222.2	45	76	4.3	90	315L1-4	160
350X300-400	350	300	1450	1200	333.3	45	77	4.5	100	355M2-4	250
350X300-500	350	300	980	1200	333.3	35	82	4.5	70	355M2-6	200

### Pump Intalling Dimensions(mm)

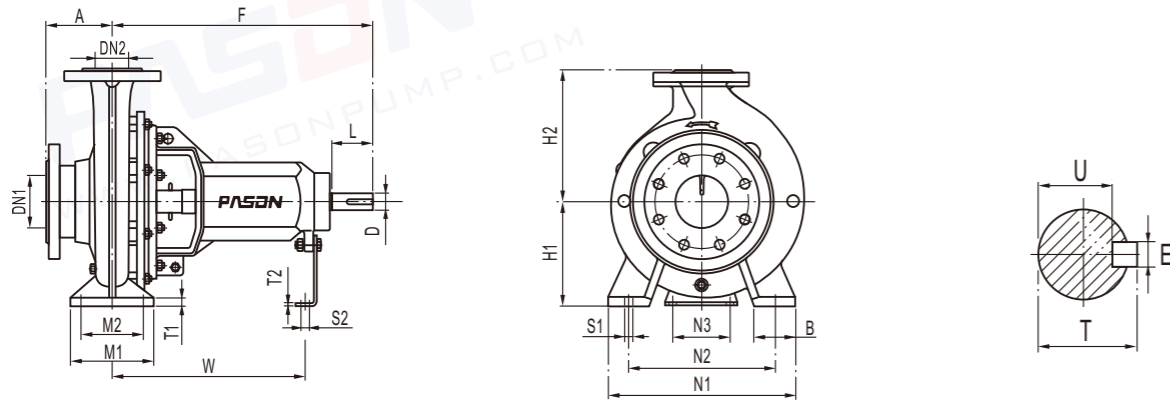

Pump Model	Flange Size		Pump Dimensions				Foot Dimensions						Bolt Holes		Shaft End						Weight (kgs)		
	DN1	DN2	A	F	H1	H2	B	M1	M2	N1	N2	N3	W	T1	T2	S1	S2	D	L	T		E	U
150X125-250	150	125	140	530	250	355	80	160	120	400	315	110	370	19	6	M16	M12	42	110	45	12	37	152
150X125-315	150	125	140	530	280	355	100	200	150	500	400	110	370	20	6	M20	M12	42	110	45	12	37	177
150X125-400	150	125	160	530	315	400	100	200	150	500	450	110	370	18	6	M20	M12	42	110	45	12	37	201
200X150-315	200	150	160	670	315	400	100	200	150	550	450	140	500	25	10	M20	M16	48	110	51.5	14	42.5	261
200X150-400	200	150	160	670	315	450	100	200	150	550	450	140	500	25	10	M20	M16	48	110	51.5	14	42.5	300
250X200-200	250	200	180	670	315	450	100	200	150	550	450	140	500	22	10	M20	M16	48	110	51.5	14	42.5	360
250X200-250	250	200	180	885	315	450	100	200	150	550	450	180	670	25	12	M24	M16	65	140	69	18	58	502
250X200-315	250	200	180	670	315	450	100	200	150	550	450	140	500	25	10	M20	M16	48	110	51.5	14	42.5	293
250X200-400	250	200	180	670	355	480	120	220	170	600	480	110	505	20	6	M26	M12	48	110	51.5	14	42.5	358
300X250-250	300	250	225	885	355	560	125	250	190	630	500	180	670	24	12	M24	M16	65	140	69	18	58	515
300X250-315	300	250	225	670	355	500	125	250	190	690	560	140	500	24	12	M20	M16	48	110	51.5	14	42.5	375
300X250-350	300	250	220	682	400	560	150	250	200	660	510	110	516	26	6	M26	M12	48	110	51.5	14	42.5	386
300X250-400	300	250	220	682	400	560	150	250	200	660	510	110	516	26	6	M26	M12	48	110	51.5	14	42.5	400
350X300-400	350	300	250	975	450	600	180	315	250	760	630	180	730	24	12	M24	M16	75	170	79.5	20	67.5	795
350X300-500	350	300	250	975	500	650	225	360	270	900	750	180	730	32	12	M30	M16	75	170	79.5	20	67.5	928

### Flange Connecting Dimension (ISO 2084,PN16)

DN	ød	øk	ØD	n	øS
125	184	210	250	8	18
150	211	240	285	8	22
200	266	295	340	12	22
250	320	355	405	12	26
300	370	410	460	12	26
350	429	470	520	16	26

Notes: 1. Optional Flange: AS2129-1982, ANSI 16.1-1975, JISB 2210-1984

### Service Connections

Pump Model	A	B	D	S
	Casing Drain	Housing Drain	Gauge Drain	Gauge Drain
150X125-250	1/4	3/8	1/4	1/4
150X125-315	1/4	3/8	1/4	1/4
150X125-400	3/8	1/4	1/4	1/4
200X150-315	3/8	3/8	3/8	3/8
200X150-400	3/8	1/4	1/4	1/4
250X200-200	3/8	3/8	3/8	3/8
250X200-250	1/2	3/8	1/2	1/2
250X200-315	3/8	3/8	3/8	3/8
250X200-400	3/8	1/4	1/4	1/4
300X250-250	1/2	3/8	1/2	1/2
300X250-315	1/2	1/2	1/2	1/2
300X250-350	3/8	1/4	1/4	1/4
300X250-400	3/8	1/4	1/4	1/4
350X300-400	1/2	1/2	1/2	1/2
350X300-500	1/2	1/2	1/2	1/2

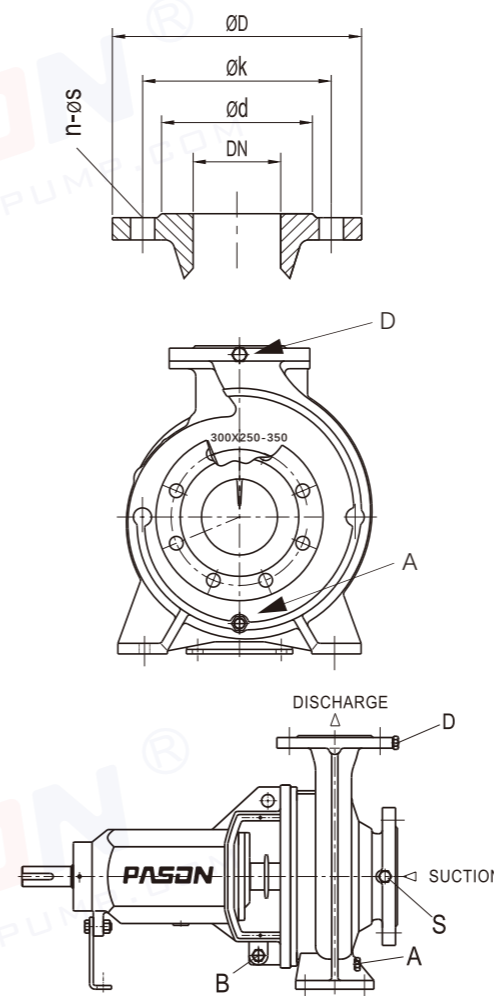

### Performance Chart (50Hz)

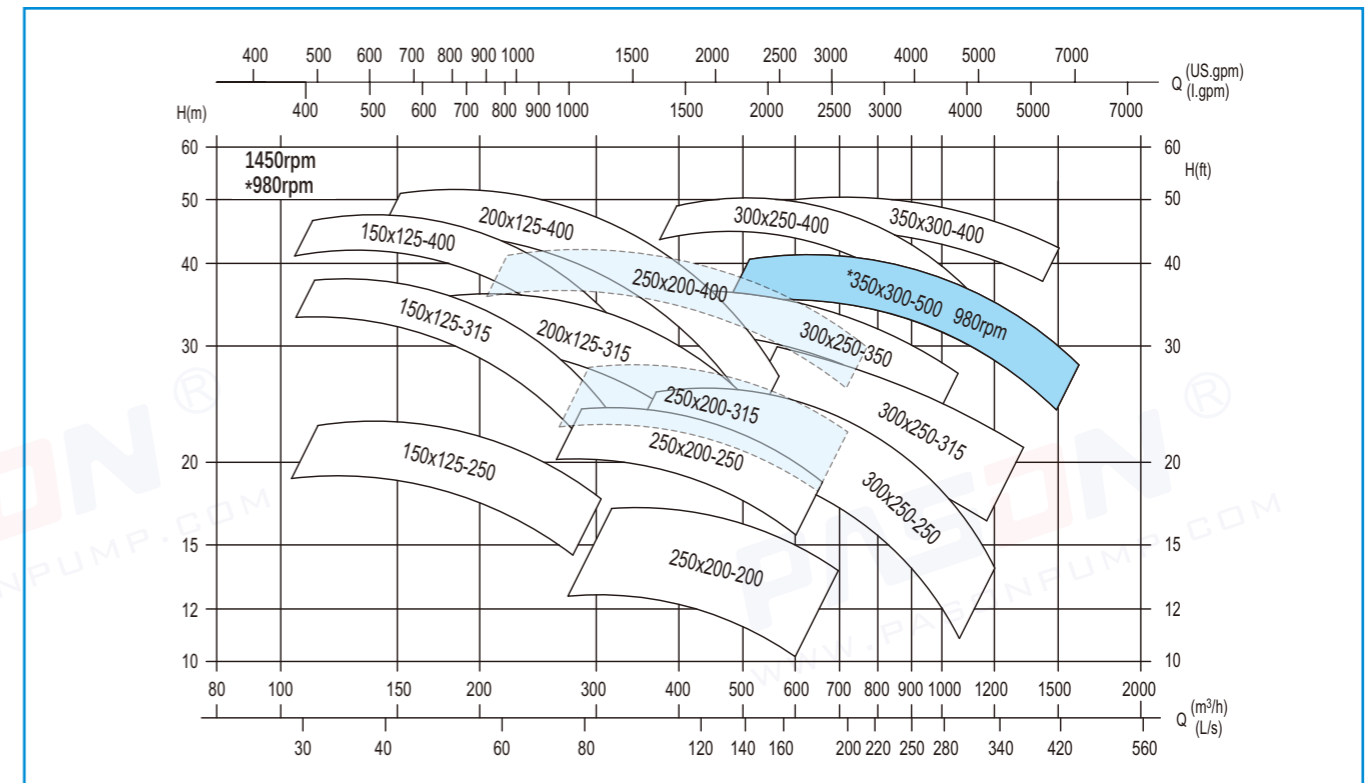

## PPW Series Non-Clogging Process Pump

### Impeller Type

#### 3-Vane Impeller

Contaminated, Max 100mm solids-laden fluids not containing stringy material and containing no or very little entrapped gas

#### PPW-K:

Suitable for the following fluids:  
Contaminated, solids-laden fluids not containing stringy material and containing no or very little entrapped gas

#### PPW-O:

Suitable for the following fluids:  
Fluids containing coarse solids and stringy material as well as fluids with entrapped gas and entrapped air

### Heavy Duty Tough Bearings

Cylindrical roller bearing at the impeller end, two angular contact ball bearing (back to back arrangement) at the drive end. Design bearing life up to 25000 hours. Long service life  
Oil Lubricated rolling element bearings

### Sturdy Shaft

Ensures minimum shaft deflection and low mechanical vibration

### Wear Plate

#### PPW-K:

Without casing wear plate, only 2 models with casing cover wear plate design

#### PPW-O:

With casing wear plate, only 2 models with casing cover wear plate design

### Application

The **PPW** pump is suitable for handling water or similar liquids mainly used in the following.

- Chemical and Petrochemical Industry
- Oil refining plants
- Pulp and Paper making industry
- Waste water treatment
- Pharmaceutical
- Food Industry(e.g.sugar)

### Axial Force Balance

The axial force are mostly balance by the rear wear plate and balanceing back blads in impeller design, The residual axial force are balanced by the back to back arranged contact ball bearings at the drive end.

### Flange

Flange dimensions comply to ISO 7005-1:1992 PN16 Mpa as standard, other flange(including ANSI flange) are also available by request

### Shaft sealing

Single mechanical seal as standard, Gland Packing, Double mechanical seal are available

### Drive

Electric motor / Diesel engine connected to the pump via a coupling or belt drive

## Section Drawing

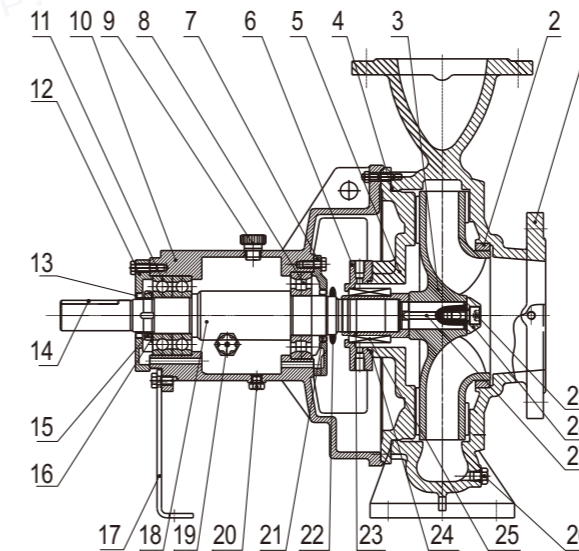

PPW-K

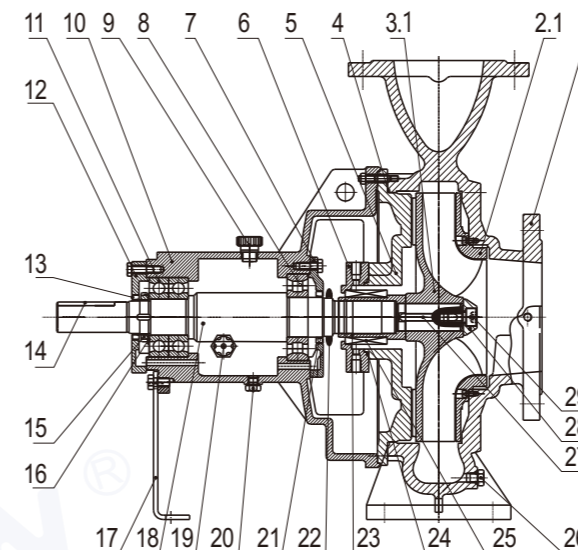

PPW-O

S/N	Part Name
1	Pump Casing
2	Casing wear ring
2.1	Casing wear plant
3	Close Impeller
3.1	Semi open Impeller
4	O-Ring
5	Casing Cover
6	Seal Gland
7	Bearing Cover
8	Cylindrical roller bearing
9	Oil hole cover
10	Bearing Housing
11	Angular contact ball bearing
12	Bearing Cover
13	Lip Seal
14	Coupling Key
15	Round Nut
16	Tab Washer
17	Support Foot
18	Pump Shaft
19	Oil Indicator
20	Drain Plug
21	Lip Seal
22	Slinger
23	Shaft Sleeve
24	Oil Seal
25	Mechanical Seal
26	Drain Plug
27	Impeller Key
28	Impeller Washer
29	hexagon Bolts

# PZA Series

## Petrol-Chemical Process Pump

### Product Overview

PZA petrochemical process pumps are designed in accordance with AP1610(10th edition) and VDMA24297(Light/Medium) specifications. Its excellent hydraulic model and structural features ensure that users can effectively reduce the operating costs of pumps in various applications.

### Applications

This pump is suitable for transporting clean liquids or liquids containing particles, low or high temperature liquids, and neutral or corrosive liquids. Mainly used for:

- The oil refinery, petrochemical industry, coal processing industry, and cryogenic engineering
- The chemical industry, paper and pulp industry, sugar industry, and general process industry
- Water supply plant and seawater desalination plant
- Heating and air conditioning system
- Environmental protection project
- Shipbuilding and the marine industry

### Operating Limits

Diameter (DN): 32~300 (mm)  
 Flow rate (Q): up to 1500m³/h  
 Head (H) : up to 160m  
 Pressure (P): up to 1.6MPa  
 Temperature (T): -40°C +175°C  
 (depend on medium features and sealing materials)

### PRODUCT FEATURES

#### Pump Casing

The pump casing is with stainless steel material, And it is made by Investment Casting. The flange conforms to GB/T9113(steel), PN16MPa standard.It can also used with the following equivalent standard flange:BS 4504,ISO7005.1,DIN2533,ISO7005.2. The casing is with Back-pull out design. It is easy maintenance without affecting the pipeline.

#### Casing Cover

The casing cover reserves a heating/heat preservation chamber and mech.Seal chamber, Connecting with the cooling water flushing,it can improve the Mech.Seal working condition,reduce the impact of the heat transfer on the bearing, Increase the pump stable operation

#### Impeller

Investment Casting, Stainless Steel Material. Excellent hydraulic design combined with CFD Optimization.Static and Dynamic balancing. Improve the Operation stability of the Pump unit.

### Model Designation(Examples): PZA 200X150-500

PZA	200	150	500
Series	Suction(mm)	Discharge(mm)	Impeller Normal Diameter(mm)



#### Shaft Seal

Standard: Single Mech.Seal  
 Optional: Double Mech.Seal, Cartridge Mech.Seal and Gland Packing

#### Bearing Housing

The Bearing structure Comforms to AP610. The Casing side bearing is with Cylindrical roller bearing,The other side is with back to back angular contact ball bearing. The Bearing housing fin combined with oil lubrication can reduce the Bearing Temperature so to keep the pump stable operation

### Sectional Drawing

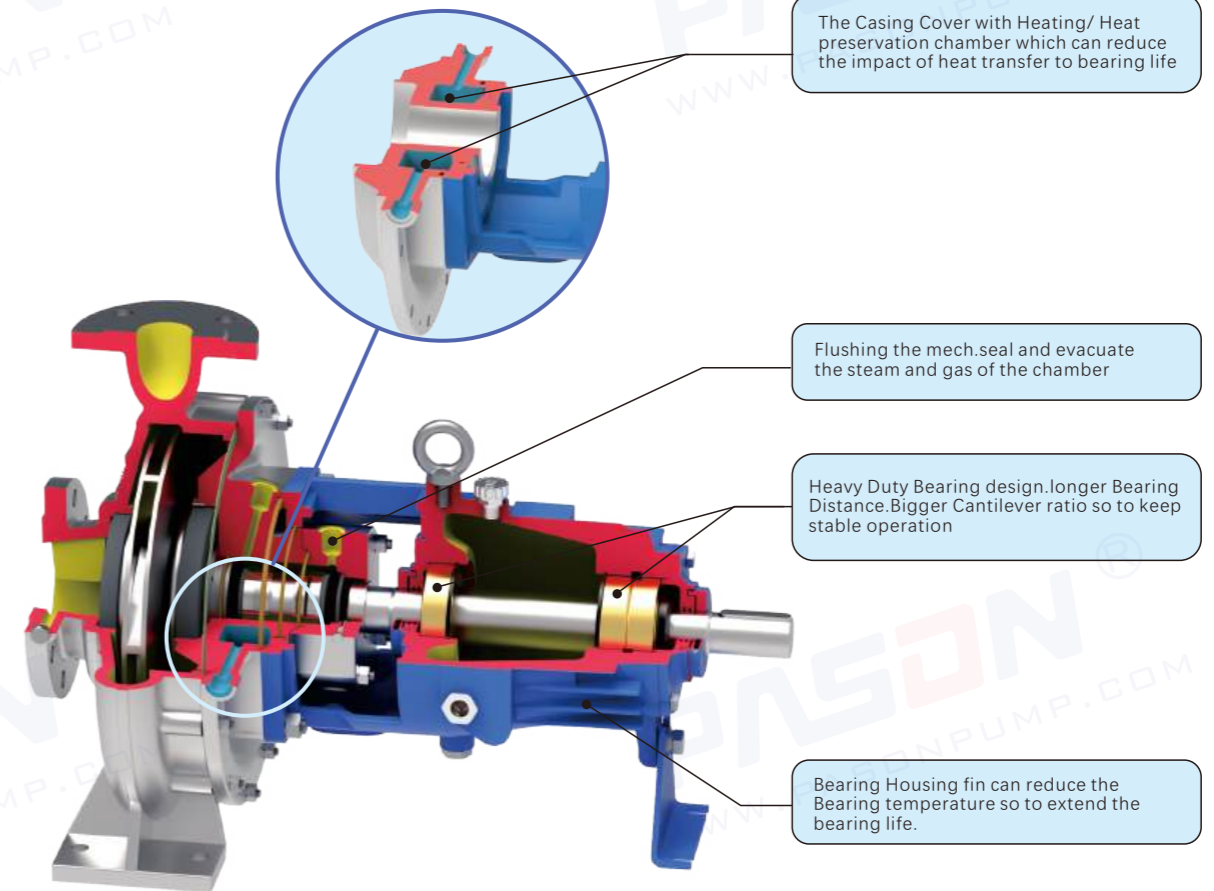

The Casing Cover with Heating/ Heat preservation chamber which can reduce the impact of heat transfer to bearing life

Flushing the mech.seal and evacuate the steam and gas of the chamber

Heavy Duty Bearing design,longer Bearing Distance.Bigger Cantilever ratio so to keep stable operation

Bearing Housing fin can reduce the Bearing temperature so to extend the bearing life.

### PZA Pump Explosive View

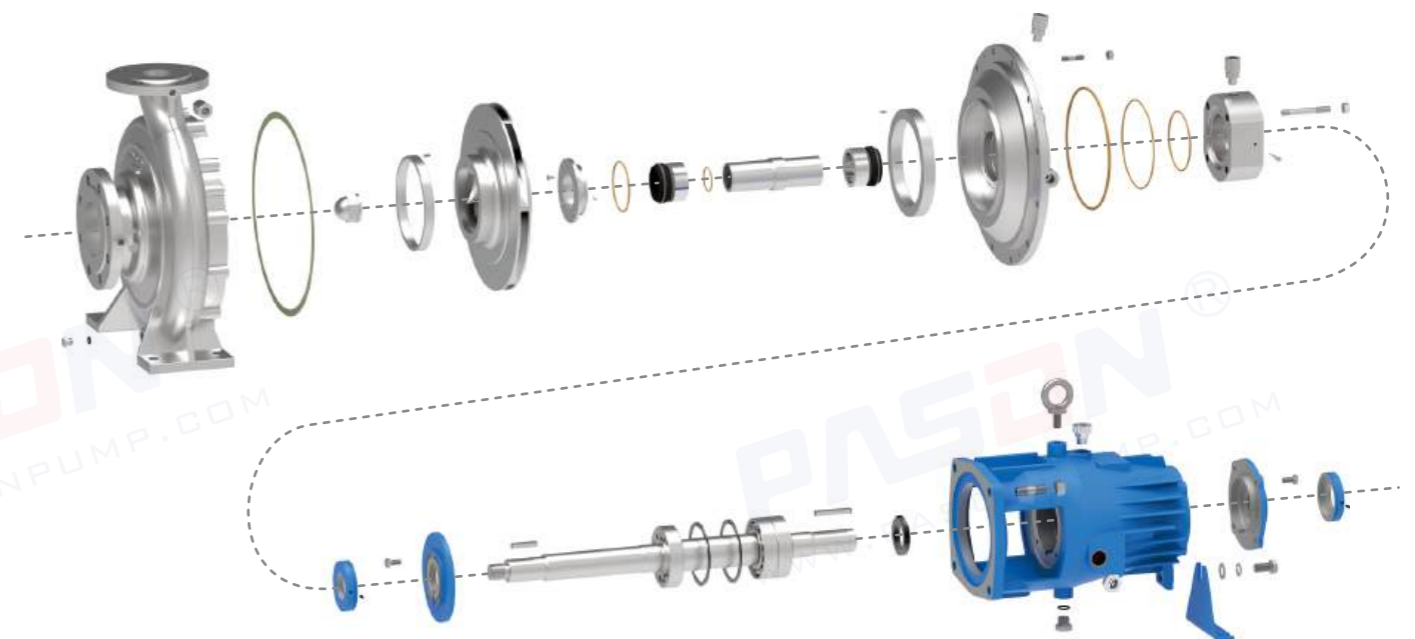

**PZA Series** Petrol-Chemical Process Pump

**Section Drawing**

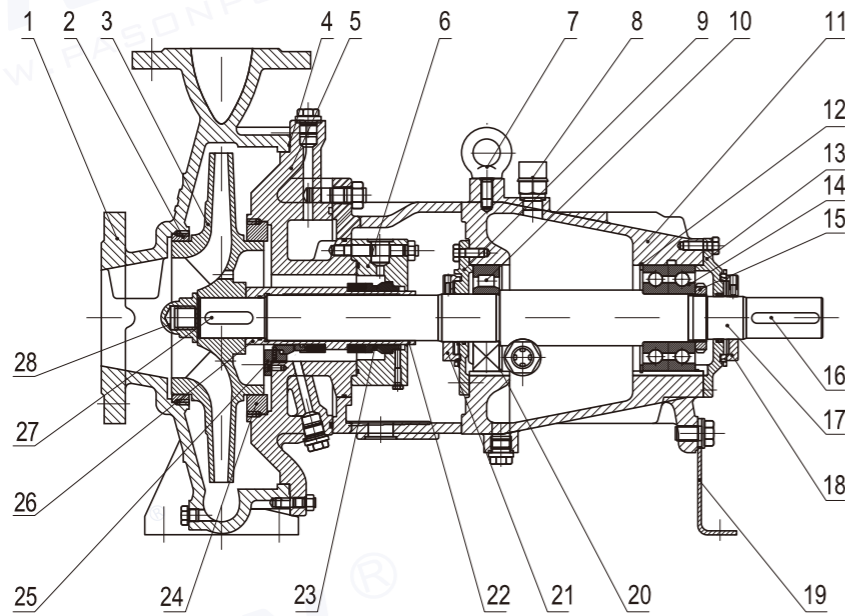

**Standard**  
Single mechanical seal

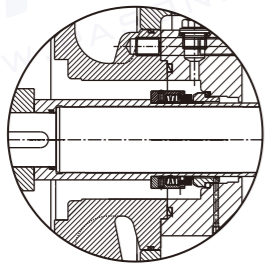

**Optional**  
Double mechanical seal

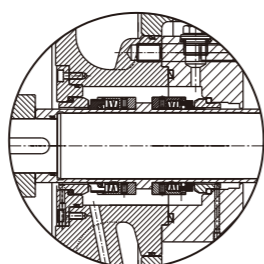

S/N	Part Name
1	Pump Casing
2	Front Wear Ring
3	Impeller
4	PTFE Gasket
5	Casing Cover
6	Seal Gland
7	Rings
8	Oil hole cover
9	Bearing cover
10	Cylindrical roller bearing
11	Bearing Housing
12	External Circlip
13	Bearing cover
14	Angular contact ball bearing

S/N	Part Name
15	Bearing Lock Nut
16	Coupling Key
17	Pump shaft
18	labyrinth seal
19	Support Foot
20	External Circlip
21	labyrinth seal
22	Shaft Sleeve
23	mechanical seal
24	Rear Wear Ring
25	Seal plate
26	Shaft Sleeve
27	Impeller Key
28	Impeller Nut

**Flange Connecting Dimension (ISO 7005.2:1988)**

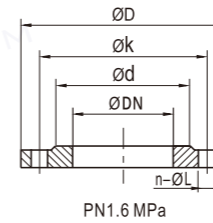

DN	Ød	Øk	ØD	n-ØL
32	76	100	140	4×Ø18
40	84	110	150	4×Ø18
50	99	125	165	4×Ø18
65	118	145	185	4×Ø18
80	132	160	200	8×Ø18
100	156	180	220	8×Ø18
125	184	210	250	8×Ø18
150	211	240	285	8×Ø22
200	266	295	340	12×Ø22
250	320	355	405	12×Ø26
300	370	410	460	12×Ø26

**Intalling Dimensions**

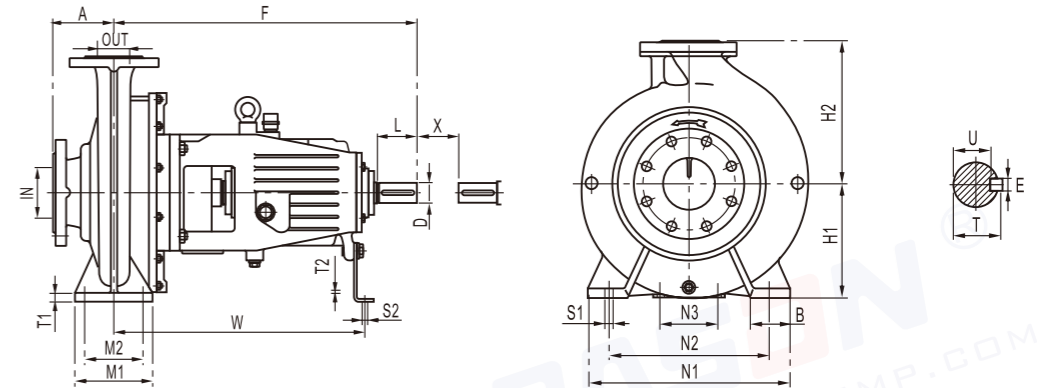

Pump Model	Shaft No.	Pump Dimensions				Foot Dimensions							Bolt Holes		Shaft End					Spacer X ≥	Net Weight (kgs)				
		IN	OUT	IMP	A	F	H1	H2	B	M1	M2	N1	N2	N3	W	T1	T2	S1	S2			D	L	T	E
50	32	160	1	80	470	132	160	50	100	70	240	190	110	418	12	6	M12	M12	24	33.5	27	8	20	100	38
50	32	200	1	80	470	160	180	50	100	70	240	190	110	418	12	6	M12	M12	24	33.5	27	8	20	100	46
65	50	160	1	80	470	132	160	50	100	70	240	190	110	418	12	6	M12	M12	24	33.5	27	8	20	100	40
65	40	200	1	100	470	160	180	50	100	70	265	212	110	418	13	6	M12	M12	24	33.5	27	8	20	100	48
65	40	250	2	100	560	180	225	65	125	95	320	250	110	483	14	6	M12	M12	32	55.5	35	10	27	100	70
65	40	315	2	125	560	200	250	65	125	95	345	280	110	483	16	6	M12	M12	32	55.5	35	10	27	100	80
80	65	160	1	100	470	160	180	50	100	70	265	212	110	418	13	6	M12	M12	24	33.5	27	8	20	100	46
80	50	200	1	100	470	160	200	50	100	70	265	212	110	418	13	6	M12	M12	24	33.5	27	8	20	100	52
80	50	250	2	125	560	180	225	65	125	95	320	250	110	483	15	6	M12	M12	32	55.5	35	10	27	100	72
80	50	315	2	125	560	225	280	65	125	95	345	280	110	483	18	6	M12	M12	32	55.5	35	10	27	100	87
100	80	160	2	100	560	160	200	65	125	95	280	212	110	483	14	6	M12	M12	32	55.5	35	10	27	100	68
100	65	200	2	100	560	180	225	65	125	95	320	250	110	483	14	6	M12	M12	32	55.5	35	10	27	140	70
100	65	250	2	125	560	200	250	80	160	120	360	280	110	483	16	6	M16	M12	32	55.5	35	10	27	140	80
100	65	315	3	125	625	225	280	80	160	120	400	315	110	524	18	6	M16	M12	42	79.5	45	12	37	140	118
125	80	400	3	125	625	280	355	80	160	120	435	355	110	524	20	6	M16	M12	42	79.5	45	12	37	140	165
125	100	200	2	125	560	200	280	80	160	120	360	280	110	483	17	6	M16	M12	32	55.5	35	10	27	140	85
125	100	250	3	140	625	225	280	80	160	120	400	315	110	524	18	6	M16	M12	42	79.5	45	12	37	140	126
125	100	315	3	140	625	250	315	80	160	120	400	315	110	524	19	6	M16	M12	42	79.5	45	12	37	140	135
125	100	400	3	140	625	280	355	100	200	150	500	400	110	524	20	6	M20	M12	42	79.5	45	12	37	140	175
125	100	500	4	160	675	355	450	100	200	150	550	450	110	588	25	10	M20	M16	48	75	51.5	14	42.5	180	313
150	125	250	3	140	625	250	355	80	160	120	400	315	110	524	19	6	M16	M12	42	79.5	45	12	37	140	140
150	125	315	3	140	625	280	355	100	200	150	500	400	110	524	20	6	M20	M12	42	79.5	45	12	37	140	150
150	125	400	3	140	625	315	400	100	200	150	500	400	110	524	21	6	M20	M12	42	79.5	45	12	37	140	186
150	125	500	4	160	675	355	450	100	200	150	550	450	110	588	25	10	M20	M16	48	75	51.5	14	42.5	180	336
200	150	315	4	160	675	315	400	100	200	150	550	450	110	586	25	10	M20	M16	48	75	51.5	14	42.5	180	222
200	150	400	4	160	675	315	450	100	200	150	550	450	110	586	25	10	M20	M16	48	75	51.5	14	42.5	180	300
200	150	500	4	160	675	400	500	100	200	150	550	450	110	588	25	10	M20	M16	48	75	51.5	14	42.5	180	382
250	200	200	4	180	675	315	450	100	200	150	550	450	110	583	22	10	M20	M16	48	75	51.5	14	42.5	180	280
250	200	250	5	180	780	315	450	100	200	150	550	450	180	680	25	12	M20	M16	60	101.5	64	18	53	250	415
250	200	315	4	180	675	315	450	100	200	150	550	450	110	586	25	10	M20	M16	48	75	51.5	14	42.5	180	277
250	200	400	4	180	675	355	500	100	200	150	550	450	110	586	25	10	M20	M16	48	75	51.5	14	42.5	180	340
250	200	500	5	225	780	400	580	150	315	250	760	630	180	680	28	12	M24	M16	60	101.5	64	18	53	250	420
300	250	250	5	225	780	355	560	125	250	190	630	500	180	680	24	12	M20	M16	60	101.5	64	18	53	250	295
300	250	315	4	225	675	355	500	125	250	190	690	560	110	586	24	10	M20	M16	48	75	51.5	14	42.5	180	280
300	250	400	5	225	780	450	560	150	250	190	690	560	180	680	28	12	M24	M16	60	101.5	64	18	53	250	410
300	250	500	5	225	780	450	630	150	315	250	760	630	180	680	28	12	M24	M16	60	101.5	64	18	53	250	460

### PZA Series Petrol-Chemical Process Pump

Performance Chart (50Hz)

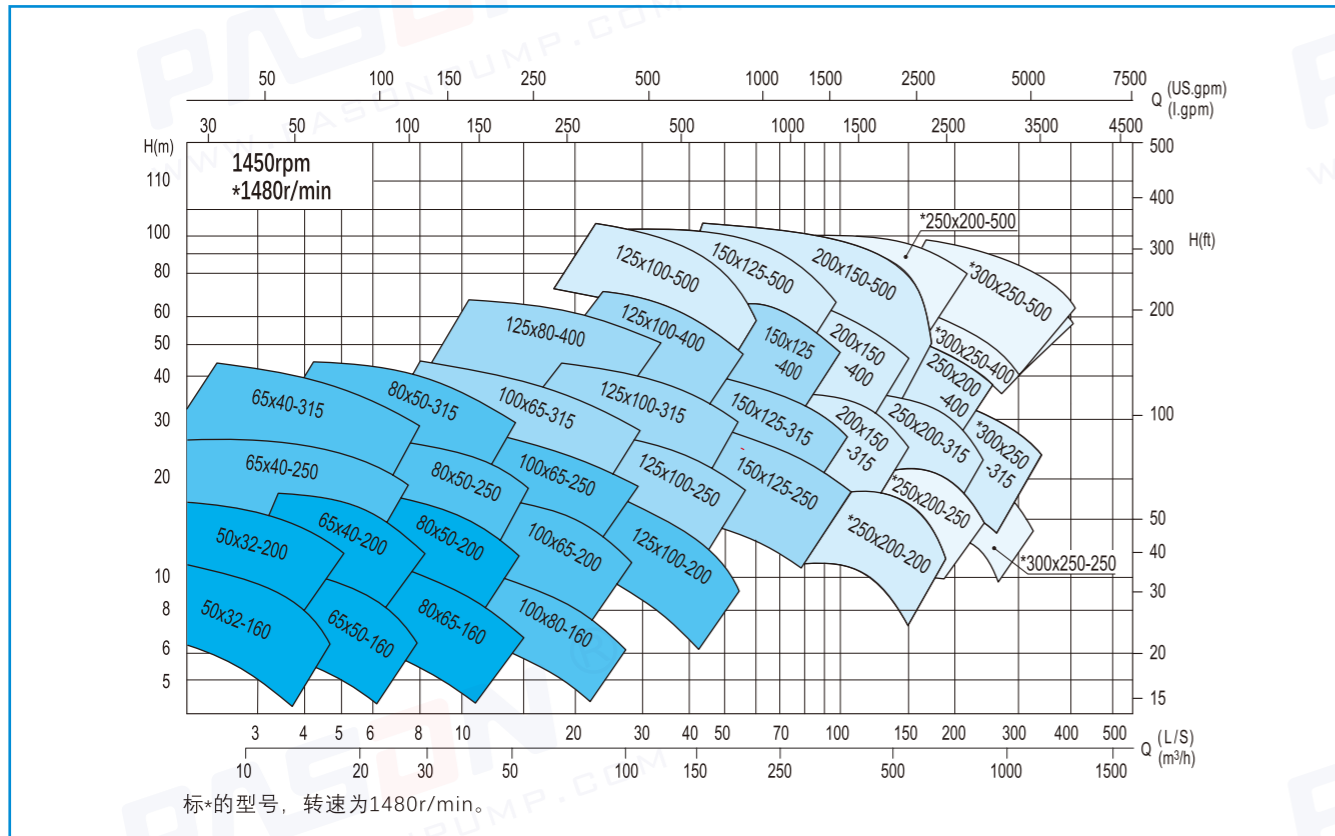

### PZA Series Petrol-Chemical Process Pump

Performance Chart (60Hz)

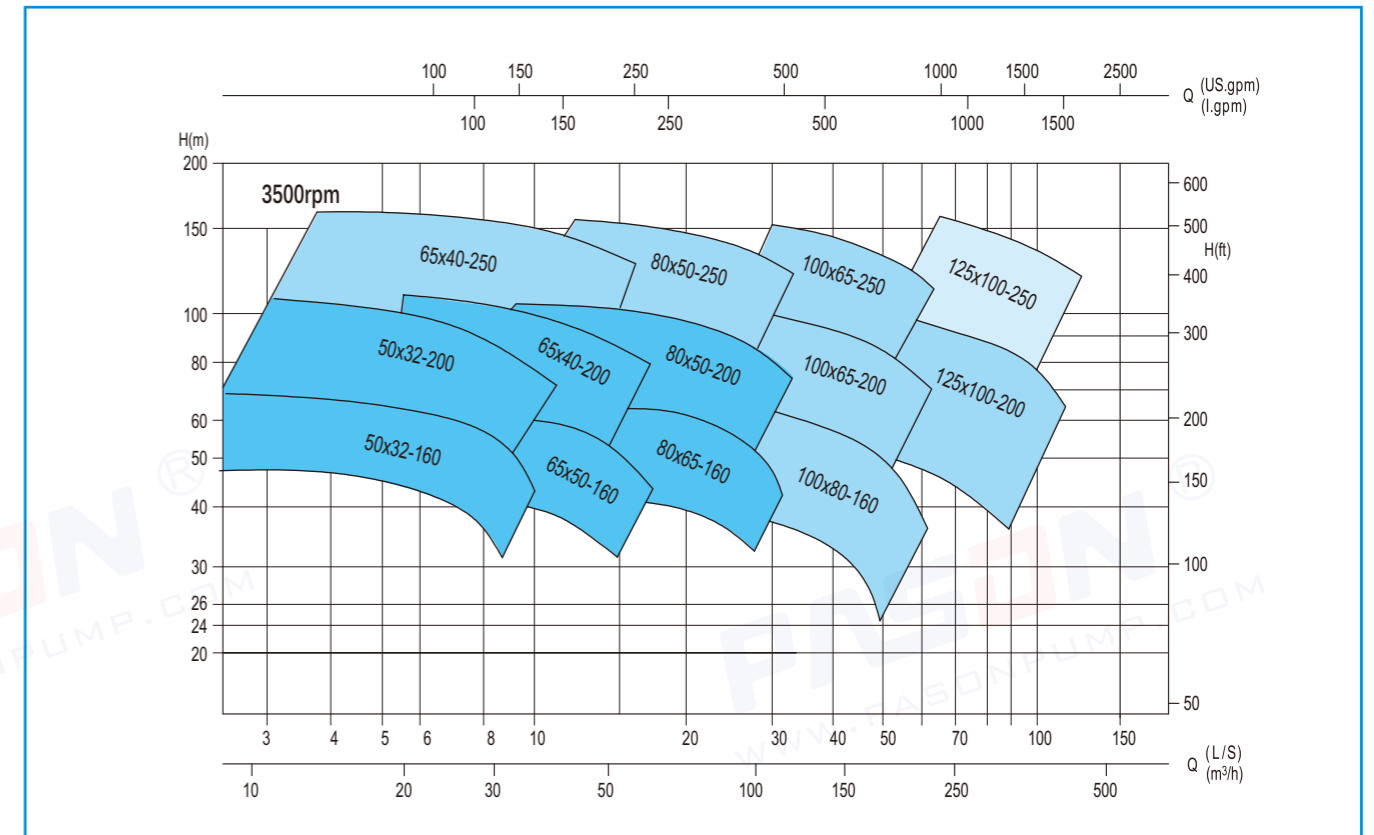
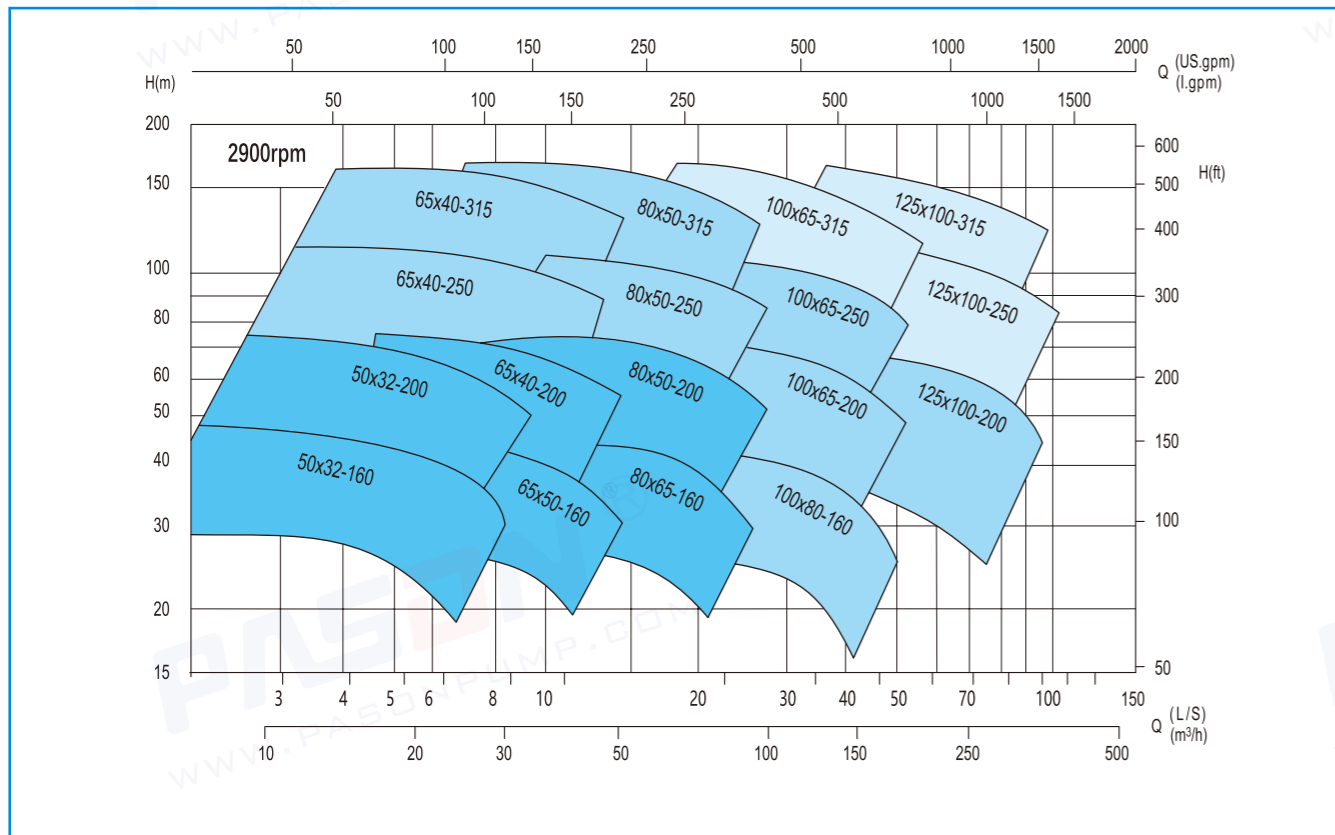
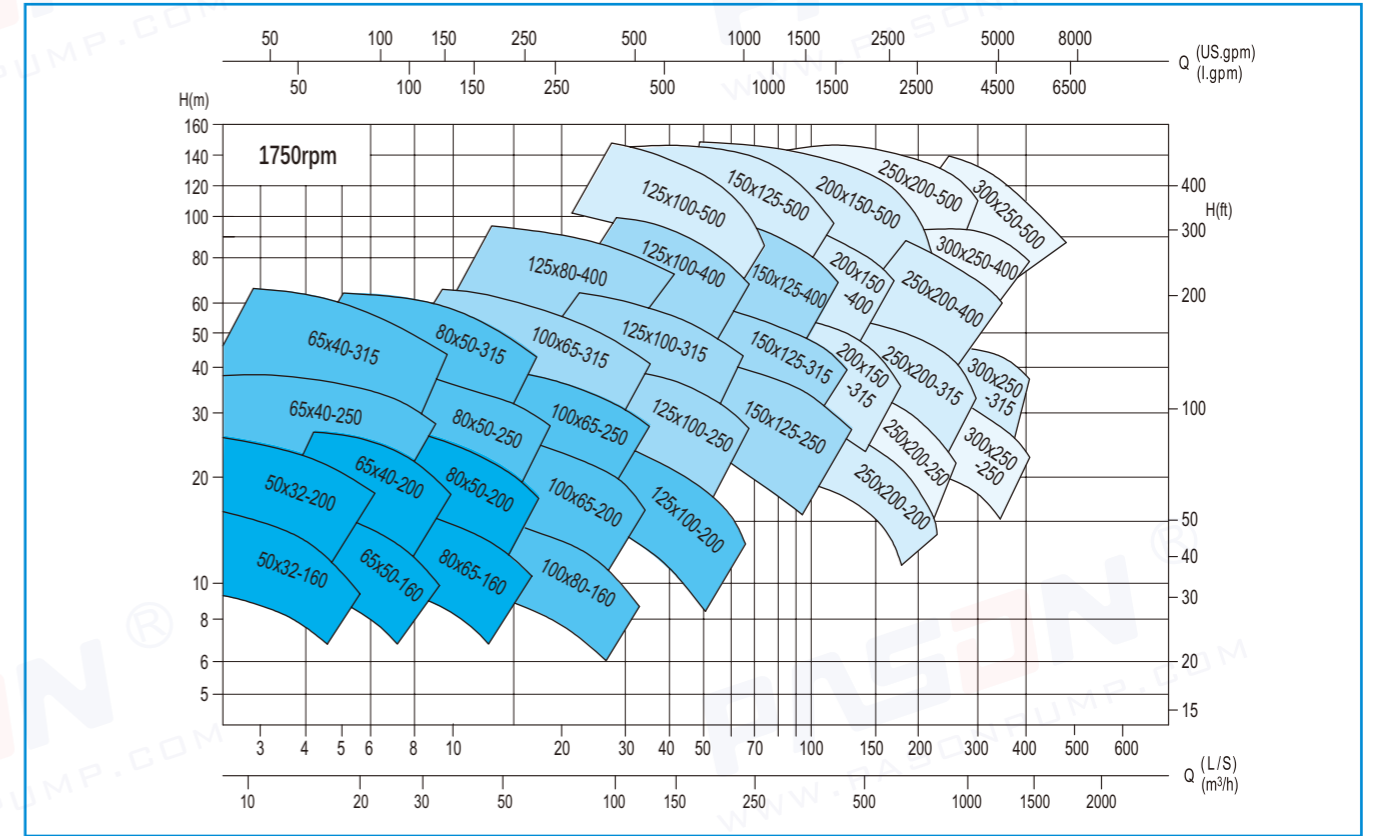

# D / MD / DF Series

## Horizontal Multi-stage Centrifugal Pump

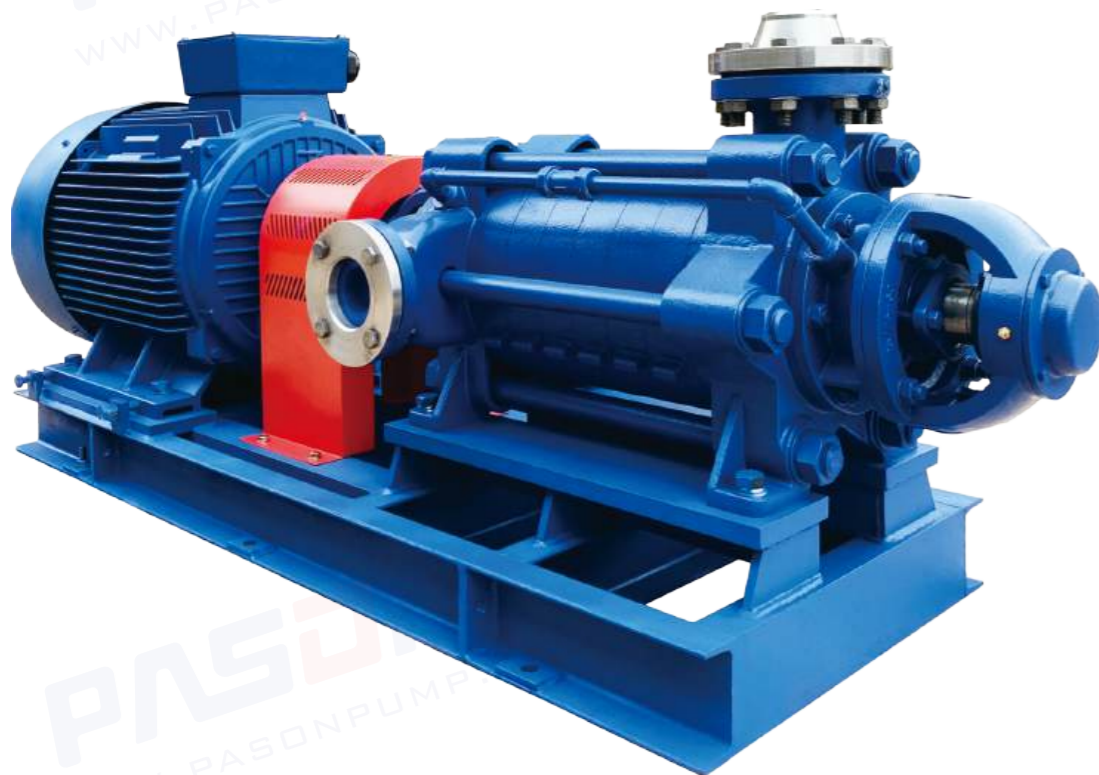

### Performance Range

**D, MD, DF:** type pump has the same performance parameters and installation size  
 Suction/Discharge: 40~300mm  
 Capacity: 3.75~850m<sup>3</sup>/h  
 Head: 19~816m

**Note:**  
 The pump performance in this book and normal temperature water testing values

### Model Designation(Examples): D(MD,DF) 46-50 X 7

<b>D</b>	<b>46</b>	<b>50</b>	<b>7</b>
Pump Series	the design point of capacity is 46 m <sup>3</sup> /h	The design point of stage head is 50m	The pump stage is 7

**D:** Multi stage clean water centrifugal pump  
**MD:** Wear resistant multi-stage centrifugal mining pump  
**DF:** Corrosion resistant multi-stage centrifugal mining pump

### Shaft Seal

standard: mechinacal seal  
 Opaton: Gland packing

### Bearing Lubrication

standard: Grease  
 Opaton: Oil

### Overview

This series of pump is of sub-horizontal. multi-stage single-suction and centrifugal, using state-recommended hydro-module. The pump is efficient. reliable, and dureble with low noise perfo rmance, easy maintenance and wide scope of usages

Our pump is applicable to deliver those fluid without solid, particles or any other suspended stuff, water fo r instance. While oily and corrosive or solid-contained fluid can be pumped by means of material modification, sealing methods, and cooling system adding.The max, inlet pressure shall be 0. 6MPa.

### Technical Features

High efficiency and Energy saving  
 We have developed our unique technology for manufacturing, model designing and making, foundry techniques of hydraulic parts in that we take advantage of precise foundry on ll wets parts to assure their brightness, cleanliness, and accurate dimensions. So the actual efficiéncy are at least 2% higher than other general mbitistage centrifugal pumps.

Advanced process equipment  
 Every single processed part will have cleaned by means of advanced imported cleaning equipment for better assembling concern. Besides material inspection, hydraulic test, static balancing testing, all pump rotors beyond 6 grades will have axial movement tested controlled within 5 millisecond, and then the balaneing test shall be made according to G2.5 grade. Recheck axial movements of all shafts after assembly to assure the quality of the pump

### Horizontal multi-stage centrifugal pumps according to their scope of use can be divided into the following types

**D type:** Multi-stage clean water centrifugal pump  
 Used for transmission of water free of solid particles and tempe rature below 80°C,or similar physical and chemical liquid. Suitable for mining, mill and city water supply and drainage.

**MD type:** Wear -resistant multi stage centrifugal mining pump  
 Used for transmission of neutral liquid from mining well or other similar liquid. The density and size of particles of the sewage shall be less than 1.5% and 0.5mm respectively. The temperature below 80°C.

**DF type:** Corrosion -resistant multi-stage centrifugal mining pump  
 Used fo r transmission of corrosive liquid with temperature below 80°C and non-solid particles, Material, sealing methods, structure of the pump and motor model can be determined by medium, gravity, density, working temperature and the suction pressure.



## D / MD / DF Series Horizontal Multi-stage Centrifugal Pump

### Executive Standard

GB/T5657-2013 Technical specification for centrifugal pumps (class III ).  
 JB/T1051-2006 Multistage centrifugal pump-Types and basic parameters.  
 MT/T114-2005 multi-stage centrifugal pumps for coal mines.  
 GB/T13006-2013NPSH for centrifugal, mixed flow and axial flow pumps.  
 GB/T13007-2011Centrifugal pump-Efficiency.

### Product Features

That suction inlet is set horizontally while discharging outlet vertically is one of peculiarities for **D, MD, DF** horizontal, single suction, segmental multistage pumps. The segments of suction, middle, discharging are connected by means of bolt. The head employs the stages of the pump.

The rotor of the pump is mainly composed of shaft and impeller, bushing, and balancing plate, which are balanced and connected to the shaft by means of straight key and shaft nut. The stages of the pump employ the impeller. The whole rotor is supported by rolling contact bearing or sliding

bearing which varies themselves according to certain situation. The rotor does not sustain any axial force, which is balanced by balancing plate. Balancing plate wear indicator is set at the end of the pump for wearing monitoring to avoid any excessive abrasion.

Fluid sealants or O-ring sealing is set between sealing surfaces of segments of inlet, middle, and discharging, while sealing ring and guide

vane sleeve are set between rotor and stator. The sealing ring and guide vane are advised to be replaced when they decrease the pumping efficiency.

Mechanical sealing and material filling sealing are two options, in which tightness of material shall be filled properly to reach a performance of drop by drop leaking. All sealing parts are integrated in sealing housing which is under pressure of water used for water sealing, cooling and lubricating. A replaceable guide vane is necessary to protect the shaft.

The rotor of the pump during operation is allowed to swin axially. This series of pump often integrates with rolling contact bearing and grease lubricating construction.(D85-67 and D155-67 types however can adopt sliding bearing and thin oil lubricating structure or rolling contact bearing and g rease lubricating structure.)

This series of pump is driven directly by prime motor by flexible COUpling. The pump rotates clockwise from perspective of prime motor.

(Special requirement in material and constructure are all available on request, for example).

### Material of wet parts

**D** type: Cast iron material wet parts; 1045, 080M46 ASTM steel for shaft.

**MD** type: Wear-resistant cast iron or ductile iron for wet parts.

**DF** type: Availabilities of cast steel and stainless steel for wet parts are chosen according to temperature and corrosiveness of the medium.

### Structure Diagram

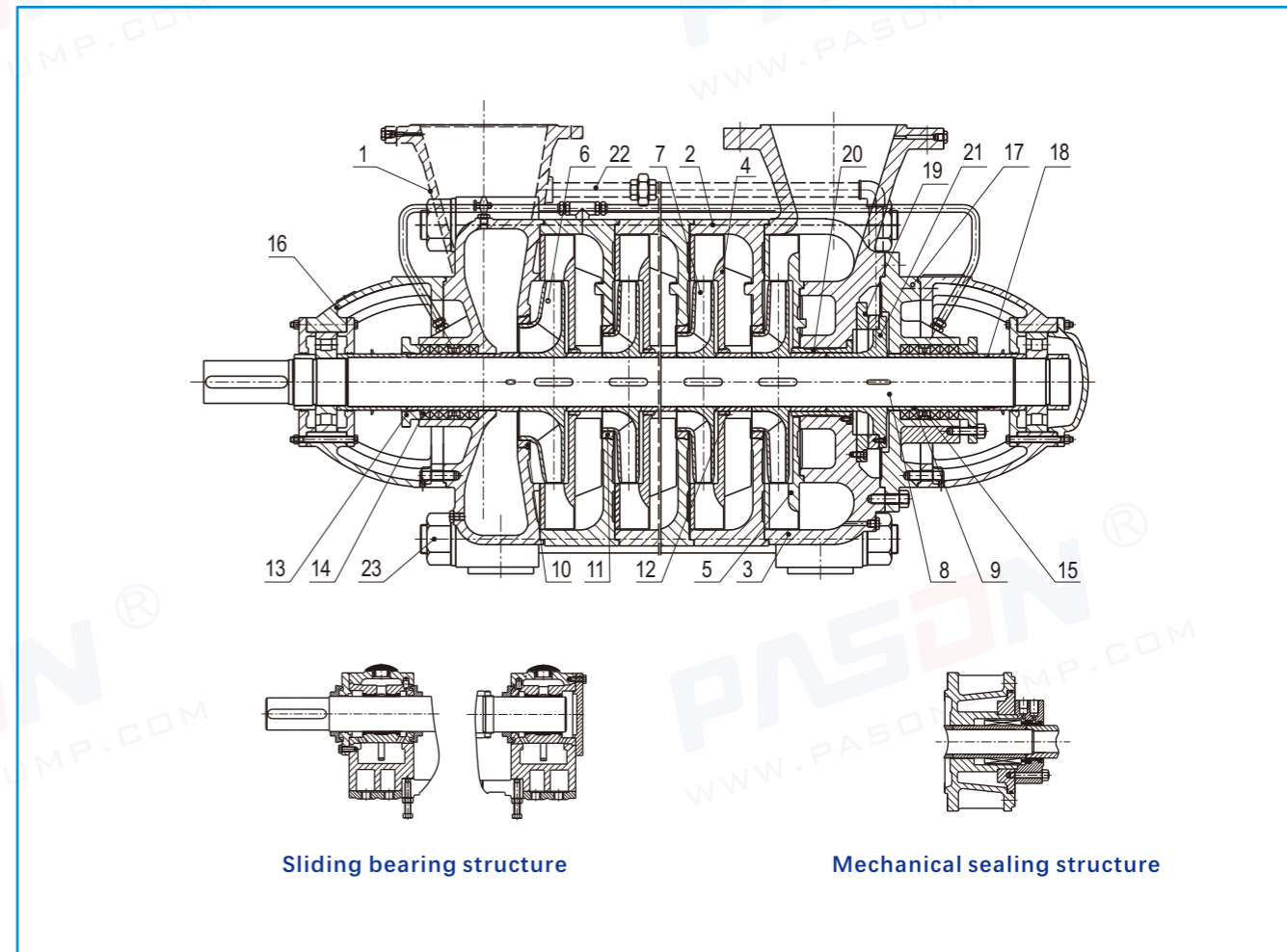

S/N	Part Name
1	Suction Casing
2	Stage Casing
3	Discharge Casing
4	Guide Vanes
5	End of Guide Vanes
6	Front-stage Impeller
7	Impeller
8	Shaft
9	Shaft Sleeve
10	Front-stage sealing Rings
11	Sealing Rings
12	Guide Vane Sleeve

S/N	Part Name
13	Gland Cover
14	Gland Packing
15	Seal Cage
16	Bearing Components
17	End Gland
18	O-Ring
19	Balancing Ring
20	Balancing Sleeve
21	Balancing Disk
22	Balancing Tube Parts
23	Tie Bolt

**D / MD / DF Series** Horizontal Multi-stage Centrifugal Pump

Performance Chart

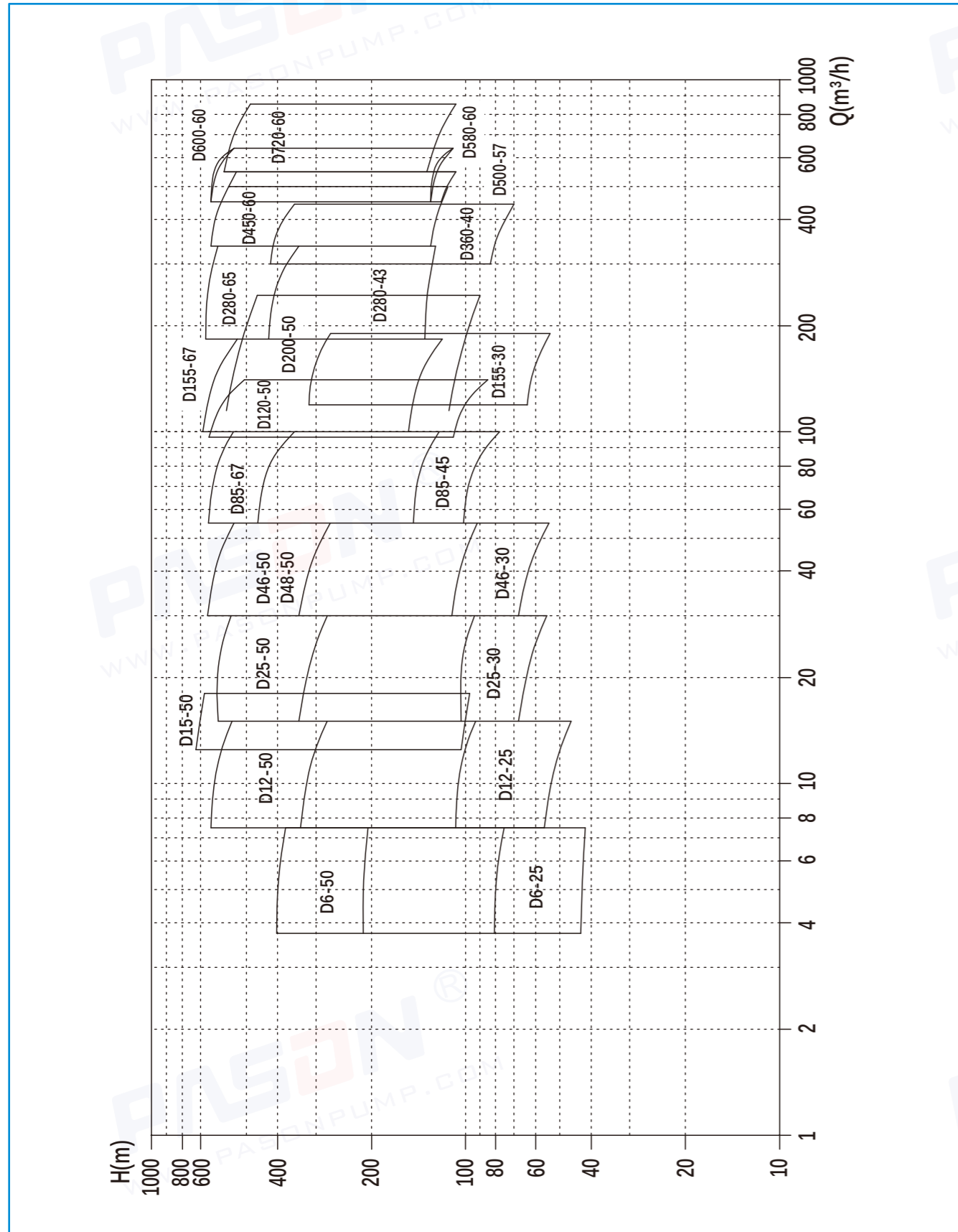

Pump Installation Dimensions Figure and Table

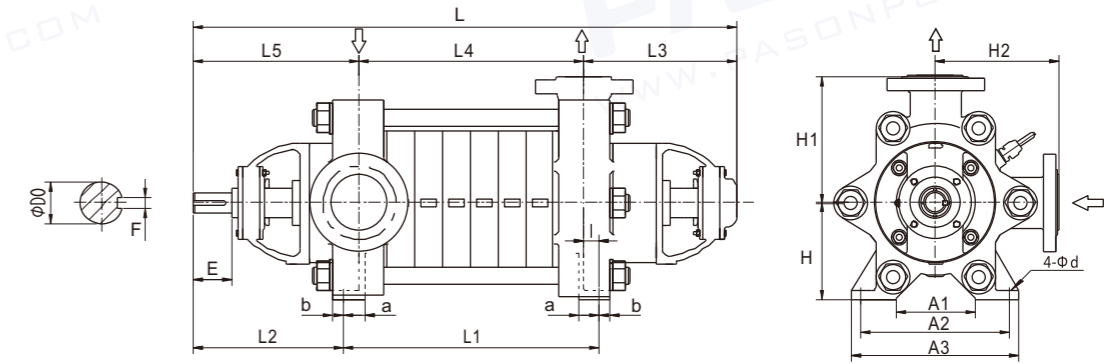

Pump Model	Pump Installation Dimensions Table																				
	stage	L	L <sub>1</sub>	L <sub>2</sub>	L <sub>3</sub>	L <sub>4</sub>	L <sub>5</sub>	H	H <sub>1</sub>	H <sub>2</sub>	I	A <sub>1</sub>	A <sub>2</sub>	A <sub>3</sub>	a	b	4- $\phi d$	E	F	D <sub>0</sub>	
D (MD/DF) 6-25 12-25	2	630	135			130															
	3	680	185			180															
	4	730	235			230															
	5	780	285			280															
	6	830	335			330															
	7	880	385	260	240	380	260	150	170	170	5	140	210	250	35	20	$\phi 14.5$	60	8	$\phi 25$	
	8	930	435			430															
	9	980	485			480															
	10	1030	535			530															
	11	1080	585			580															
	12	1130	635			630															
	D (MD/DF) 6-50 12-50	2	760	185			160														
3		820	245			220															
4		880	305			280															
5		940	365			340															
6		1000	425			400															
7		1060	485			460															
8		1120	545	288	287	520	313	170	215	215	0	200	295	350	40	30	$\phi 18.5$	80	8	$\phi 30$	
9		1180	605			580															
10		1240	665			640															
11		1300	725			700															
12		1360	785			760															
13		1420	845			820															
14		1480	905			880															
D (MD/DF) 15-50		2	881	210			185														
	3	941	270			245															
	4	1001	330			305															
	5	1061	390			365															
	6	1121	450			425															
	7	1181	510	333	363	485	355	210	270	270	3	160	320	360	45	25	$\phi 24$	88	10	$\phi 35$	
	8	1241	570			545															
	9	1301	630			605															
	10	1361	690			665															
	11	1421	750			725															
	12	1481	810			785															
	D (MD/DF) 25-30 46-30	2	777	180			165														
3		842	245	312	285	230															
4		907	310			295	327	170	210	210	0	205	295	340	40	30	$\phi 18.5$	80	8	$\phi 30$	
5		972	375			360															



**D / MD / DF Series** Horizontal Multi-stage Centrifugal Pump

Pump Inlet and Outlet Dimensions Diagram and Table

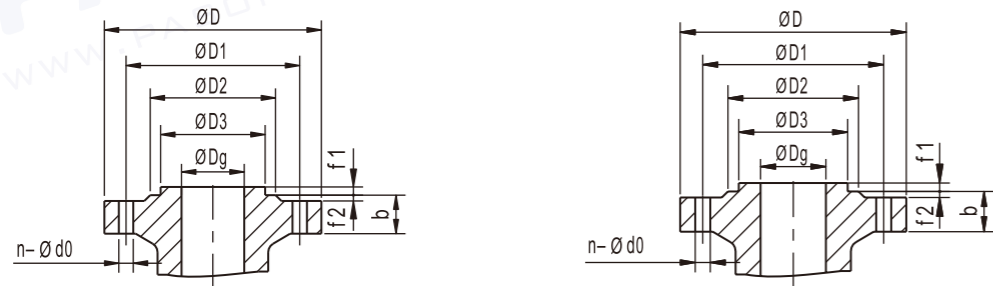

Inlet Flange

Outlet Flange

Pump Model	Inlet Flange								Outlet Flange							
	Dg	D	D <sub>1</sub>	D <sub>2</sub>	D <sub>3</sub>	b	f <sub>1</sub> /f <sub>2</sub>	n-Ød <sub>0</sub>	Dg	D	D <sub>1</sub>	D <sub>2</sub>	D <sub>3</sub>	b	f <sub>1</sub> /f <sub>2</sub>	n-Ød <sub>0</sub>
D, MD, DF 6-25	40	130	100	80	-	18	-/3	4-13.5	40	150	110	88	75	20	4/3	4-18
D, MD, DF 6-50	50	160	110	90	-	30	-/3	4-13.5	50	175	135	105	87	28	4/3	4-23
D, MD, DF 12-25	50	140	110	90	-	18	-/3	4-13.5	40	150	110	88	75	20	4/3	4-18
D, MD, DF 12-50	50	160	110	90	-	30	-/3	4-13.5	50	175	135	105	87	28	4/3	4-23
D, MD, DF 15-50	65	205	160	130	109	26	4/3	8-22	65	205	160	130	109	26	4/3	8-22
D, MD, DF 25-30	65	160	130	110	-	20	-/3	4-13.5	65	185	145	122	109	28	4/3	8-18
D, MD25-50	80	190	150	128	-	18	-/3	4-17.5	80	210	170	140	120	30	4/3	8-23
DF25-50	80	210	170	140	120	30	4/3	8-23	80	210	170	140	120	30	4/3	8-23
D, MD, DF 46-30	80	190	150	128	-	22	-/3	4-17.5	65	185	145	122	109	28	4/3	8-18
D, MD46-50	80	190	150	128	-	18	-/3	4-17.5	80	210	170	140	120	30	4/3	8-23
DF46-50	80	210	170	140	120	30	4/3	8-23	80	210	170	140	120	30	4/3	8-23
D, MD, DF 48-50	80	215	170	133	120	28	4.5/3	8-22	80	215	170	133	120	28	4.5/3	8-22
D, MD, DF 85-45	100	210	170	148	-	24	-/3	4-17.5	100	235	190	160	149	30	4.5/3	8-22
D, MD85-67	150	265	225	202	-	33	-/3	8-18	150	345	280	242	203	38	4.5/3	8-33
DF85-67	150	345	280	242	203	38	4.5/3	8-33	150	345	280	242	203	38	4.5/3	8-33
D, MD, DF 120-50	125	270	220	184	175	30	4.5/3	8-26	125	295	240	184	175	30	4.5/3	8-30
D, MD, DF 155-30	150	285	240	212	-	26	-/3	8-22	150	300	250	212	-	34	-/3	8-26
D, MD155-67	150	265	225	202	-	33	-/3	8-18	150	345	280	242	203	38	4.5/3	8-33
DF155-67	150	345	280	242	203	38	4.5/3	8-33	150	345	280	242	203	38	4.5/3	8-33
D, MD, DF 200-50	200	340	295	268	259	24	4.5/3	8-24	200	375	320	285	259	34	4.5/3	8-32
D, MD, DF 280-43	200	340	295	268	-	28	-/3	8-22	200	375	320	285	259	38	4.5/3	12-30
D, MD, DF 280-65	200	340	295	268	-	30	-/3	12-22	200	415	345	285	259	44	4.5/3	12-36
D, MD, DF 360-40	200	340	295	268	-	28	-/3	8-22	200	375	320	285	259	38	4.5/3	12-30
D, MD, DF 450-60	250	405	355	320	-	32	-/3	12-26	250	470	400	345	312	48	4.5/3	12-36
D, MD, DF 500-57	250	405	355	320	-	32	-/3	12-26	250	470	400	345	312	48	4.5/3	12-36
D, MD, DF 580-60	300	460	410	370	-	32	-/3	12-26	250	470	400	352	312	48	4.5/3	12-36
D, MD, DF 600-60	300	460	410	370	-	32	-/3	12-26	250	470	400	352	312	48	4.5/3	12-36
D, MD, DF 720-60	300	460	410	370	-	34	-/4	12-26	300	530	460	412	363	54	4.5/4	16-36

Customized Diesel Engine Fire Pump Unit System Complete Set Equipment

