

# PV MODULE-LEVEL PRECISE MANAGEMENT SOLUTION

Safety / Optimization / Efficiency

*And Solar. And All*



**AndSolar Technology Co., Ltd.**

8F, Block B, Building 1, 286 Qinglonggang Road,  
Suzhou City, Jiangsu Province, P. R. China

+86-512-8718 7882

www.andsolartech.com

sales@andsolartech.com



Facebook



LinkedIn



YouTube



Instagram

# Company Profile

AndSolar Technology is a tech-company engaged in photovoltaic module-level power electronics (MLPE) and distributed photovoltaic smart energy solutions. The company's products cover Smart Rapid Shutdown Device, Smart PV Optimizer, Smart DC Module, Smart Inverter, Gateway and AndCloud 3.0, aiming to provide safe, smart and efficient products for global users.

Based on photovoltaic systems, IoT modules, power electronics, and digital platforms, AndSolar is able to deliver module-level precise management for distributed PV plants. This integrated method enhances safety and O&M efficiency while maximizing the energy yield potential of the power plants. Committed to driving innovation, AndSolar will advance global renewable energy development and play a reliable partner for users around the world.

**1GW**

Annual Production Capacity

**400%**

Annual Business Growth

**30+**

Countries Covered

AndSolar

## R&D

- Led by senior industry experts, the team has vast experience in innovation-driven R&D and mass production of photovoltaic power electronics and IoT products
- Multiple R&D sectors are cross-driven to jointly innovate product and overcome R&D barriers

## Comprehensive Understanding

- Expertise extends across the entire photovoltaic value chain
- Vast experience in the application of integrated solutions of distributed photovoltaic system, energy storage, load management and BIPV systems

## Market Competitiveness

- Professional sales and technical team covering project development, asset management and after-sales services
- Sales channels cover various regions including Asia, Europe South America, North America, Oceania, and Africa

## Forward-Thinking Technology

- Professional vision to prepare for future competitiveness
- A keen awareness of emerging and leading PV technologies
- Global view of PV technology and market trends

# Company History

## 2021

- Complete market investigation and analysis to determine product development direction
- Gather multiple talents and form a core team

## 2022

- Found in Suzhou
- Angel investment
- Our team members have over 15 years of photovoltaic industry experience



## 2023

- Completed Pre-A round of tens of millions of financing
- Smart RSD&Gateway passed global mainstream certification and started mass production
- AndCloud 1.0 launched
- The first MW-project was deployed at Shanghai Disneyland, followed by several overseas demonstration projects successfully completed
- Set up the smart optimizer project



## 2024 H1

- Smart RSD are being shipped in bulk overseas, with MW level projects landing in the Thai market
- Smart optimizer passed global mainstream certification
- AndCloud 2.0 launched
- Set up the Gen 2 gateway project



## 2024 H2

- Cumulated shipment of 100,000 sets
- Smart optimizer in mass production, receiving a large number of orders
- Gen 2 gateway started mass production
- Completed the A round of financing of tens of millions with atotal financing of nearly 100 million
- Recognized as a "Technology-based SME" of Jiangsu Province
- Recognized as a "Leading Entrepreneurial Enterprise" of Xiangcheng District, Suzhou
- Won the first prize in the Energy Electronics Industry Innovation Competition held by the Ministry of Industry and Information Technology



## 2025 H2

- Cumulated shipment of 300,000 sets
- Smart 1 to 2 optimizer in massive production
- AndCloud 3.0 launched
- Market expansion to South America
- Established an overseas subsidiary in Singapore
- Established the first overseas technical service center (Thailand)
- Won the Second Prize at the BRICS Industrial Innovation Competition by the Ministry of Industry and Information Technology
- Recognized as a National High-Tech Enterprise



## 2025 H1

- Gen 2 smart 1 to 2 RSD in massive production
- The world's first RSD+Optimizer hybrid installation system
- The world's first remote single-point shutdown function
- Market expansion to Europe, Australia
- China-Australia emerging leaders in clean energy excellence
- SNEC Top 10 Highlights – Megawatt Jadeite Award



## 2026

- Smart 1 to 4 RSD in massive production
- AndCloud 3.0 mobile app launch
- The MLPE+ series product launch
- Market expansion to North America
- Establish the overseas technical service center (Philippines, Brazil, Germany)



# Quality Centered World Expanded

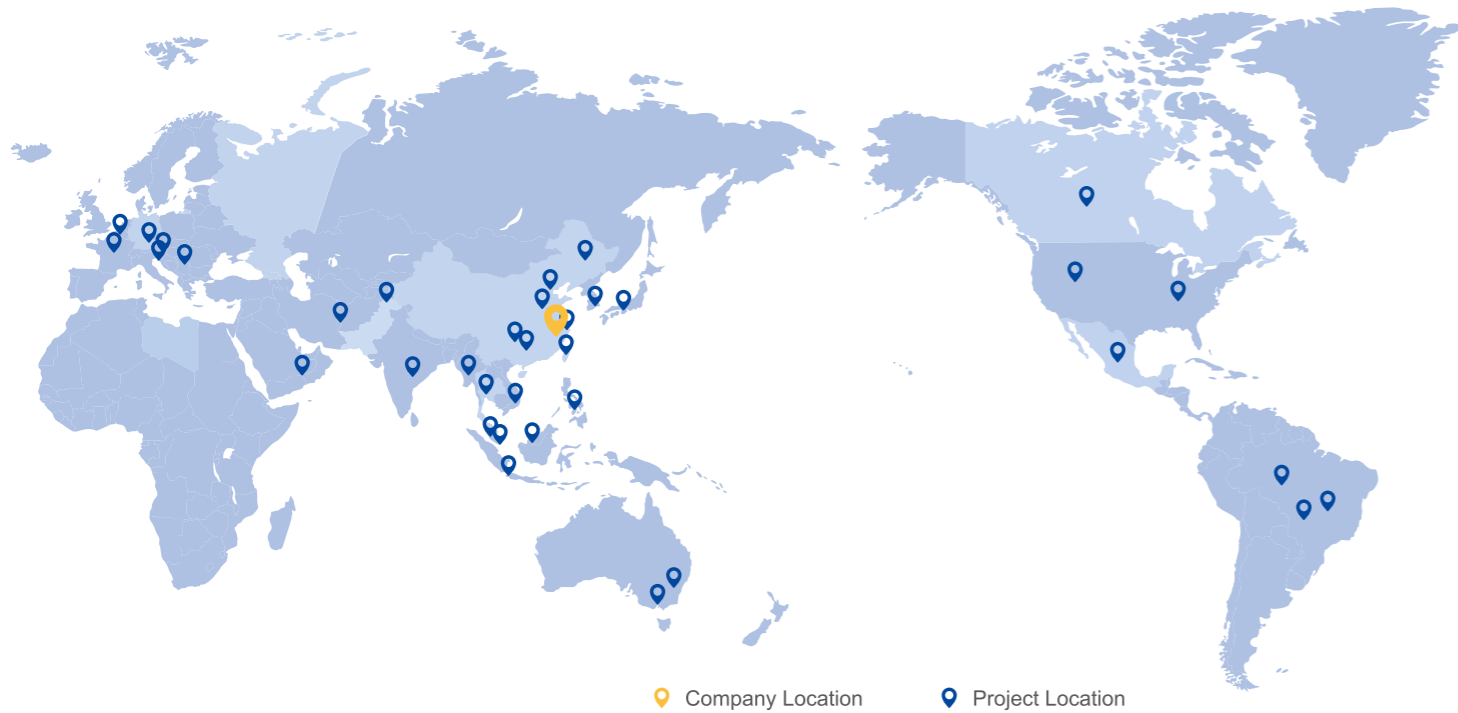

**6**  
Continents Coverage

**30+**  
Countries and Regions

**1,000+**  
Global Customers



Suzhou Factory



Suzhou Headquarter



Shanghai Branch Office

## Professional Design

- Strict component selection standards ensure long-term stability and reliability of the product
- Professional electrical and hardware design, taking EMC, heat dissipation and surge protection into account
- Product's function and safety have passed global mainstream certificates
- Environmental adaptability design meets high protection, wide temperature range, and corrosion resistance



## Rigorous Test

- AndSolar Lab implements reliability tests far beyond standard severity
  - TC400 (Thermal Cycle Test)  
Testing condition: -40°C~+85°C, 400 cycles, 2 x IEC standard
  - HF10 (Humidity Freeze Test)  
Testing condition: -40°C~+85°C, 85%RH, 10 cycles, around 240hrs
  - DH3000 (Demp Heat Test)  
Testing condition: 85°C, 85%RH, 3000 hrs, 3 x IEC standard
- \*Testing methods fulfill IEC 61215/61730 standards



## Strict Control

- Strict control of key processes such as SMT, high-precision welding, and glue filling
- Each key process of the product has passed tests such as FCT, AOI, conductivity, sealing and other tests
- Products have 100% passed high temperature aging and rated stress tests before shipment



## Continuous Upgrade

- Continuously collect feedback from market and users, keep upgrading products
- Provide OTA support throughout the product life cycle to continuously improve user experience



# Pursuing Excellent Quality

AndSolar R&D team consists of experts from PV technology, power electronics, energy IoT, and smart algorithms, all working together to develop solutions for worldwide customers. At the same time, AndSolar factory is equipped with automated production lines to ensure high-quality production.

- 15+** Years R&D Experience
- 70%** R&D Team Ratio
- 99.9%** Production Yield
- 100%** 100% aging test before shipment



# Global Certifications



AndSolar products pass the certifications demanded in the main global markets and the pass rate of the initial certification reached 100%. Our systems are rigorously tested, ensuring the safety and efficiency of power plants worldwide.



# Hybrid Solution-Commercial & Industrial

Industry-first hybrid solution of RSD+Optimizer: Install smart RSD in unshaded areas, and smart optimizers in shaded areas, which maximizes energy yield while significantly reducing investment cost.



**5-30%**  
Improve Power Generation

**50%+**  
Reduce Cost

**50%**  
Improve O&M Efficiency

**<30V**  
System Shutdown Voltage

# Hybrid Solution-Residential

Industry-first hybrid solution of RSD+Optimizer: Install smart RSD in unshaded areas, and smart optimizers in shaded areas, which maximizes energy yield while significantly reducing investment cost.

Smart Inverter



Smart DC Module

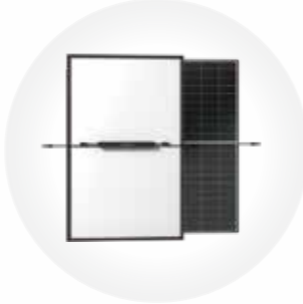

Smart Optimizer

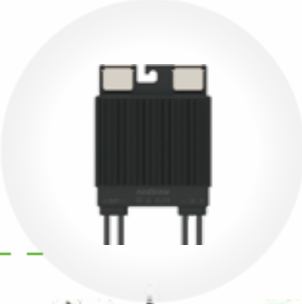

AndCloud 3.0



**5-30%**  
Improve Power Generation

**50%+**  
Reduce Cost

**50%**  
Improve O&M Efficiency

**<30V**  
System Shutdown Voltage

# AndCloud 3.0

Awaken Solar Neural Network, And Every Watt Matters

## Safety

Active and passive safety strategy, ensure the safety of the power plant

## Precision

Precise module-level monitoring around 24/7

## Efficiency

Improve the power plant O&M efficiency by 50%

## Convenience

All power plant data at a glance on a single screen



**Safety** Active and passive safety strategy, ensure the safety of the power plant

**Active Safety**

AI automatic diagnosis, prevents potential risks by active safety



**Remote Shutdown**

Shutdown one module or the entire power plant at anytime, prevent unexpected incidents, and ensure safety



**Precision** Precise module-level monitoring around 24/7

**Workspace**

Customize your AndWidget with ease, key information at a glance, and O&M operations just one click away



**Full Lifecycle Monitoring**

Multi-dimensional data comparison of the modules, with operational status easily accessible

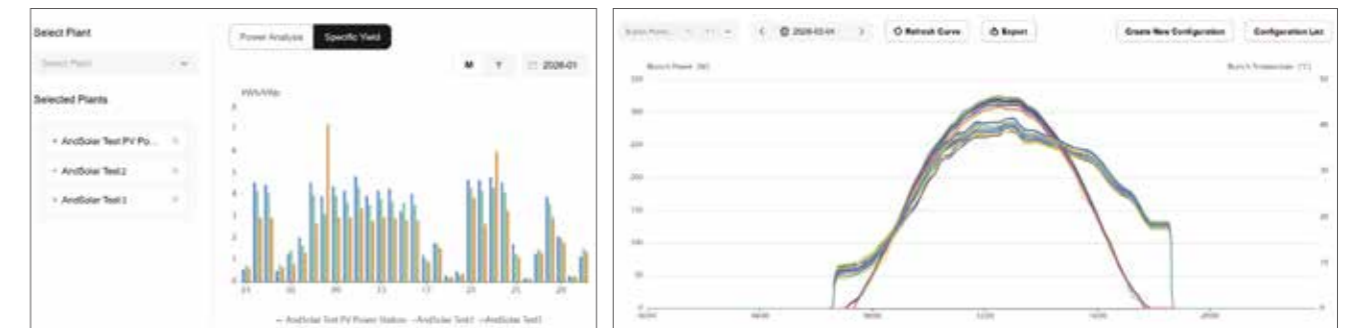

**Data Playback**

Dynamically display the operational data, and identify potential problems in your power plant

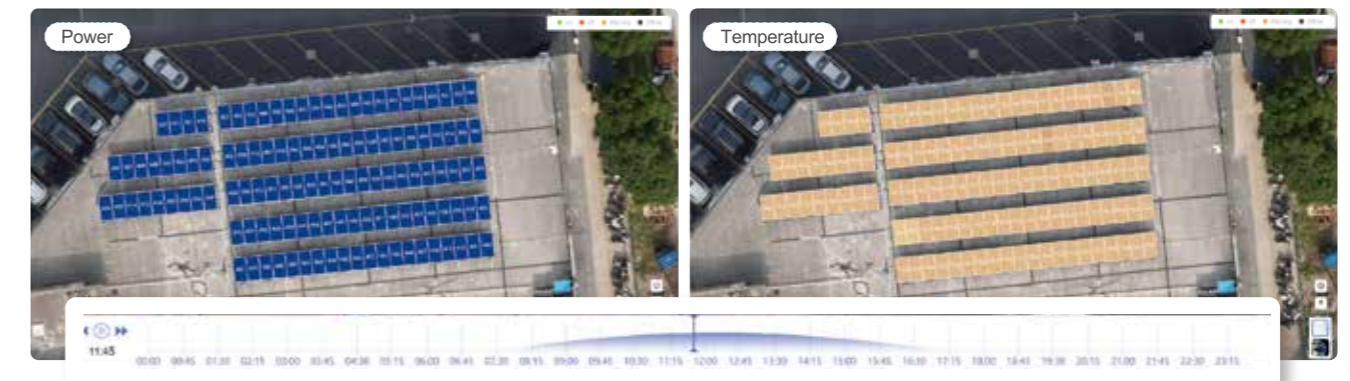

**Efficiency** Improve the power plant O&M efficiency by 50%

**Reducing inspection frequency by module-level data monitoring**

**Traditional solution**

Traditional photovoltaic power plants have low monitoring accuracy, and maintenance teams are required to conduct on-site inspections 2-3 times per quarter to ensure safety

2~3 times/quarter

VS

**AndSolar solution**

AndCloud 3.0 enables real-time monitoring of your PV system and module operation status, reducing inspection frequency

1 time/quarter



**1:1 restoration of the actual power plant scene, remote troubleshooting**

**Traditional troubleshooting**

If the capacity is 200kW with 350 modules, the investigation is expected to take 4 hours

4+ hours

VS

**Remote troubleshooting**

AndCloud 3.0→Warning List→Plant Details→Fault Location  
Especially helpful for large-scale and operationally inconvenient projects

5 mins



**Module-level management, remote shutdown low-efficiency or faulty modules and improve revenue**

**Traditional management method**

Unable to shutdown low efficiency modules in a timely manner results in reduced power generation efficiency of the power plant, requiring manual O&M, and increasing operating costs

Reduce power plant revenue

VS

**Module-level management**

The faulty modules can be shutdown in time to improve the power generation efficiency, and the power plant problems can be solved together to save O&M costs

Improve power plant revenue



**Convenience** All power plant data at a glance on a single screen

**Link Every Part of Your Power Plant**

Unified platform management breaks data silos, enabling centralized monitoring and analysis of full plant equipments



**AI Integrated, Ensure Profit**

Precise module-level management powered by AI, ensure the profit of your power plant



\*Launching in H2 2026

**Data Reports**

Customized report and export in multiple formats to meet the needs of multiple scenarios

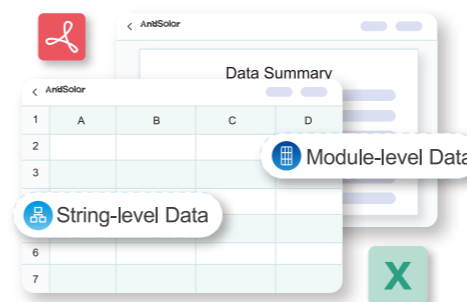

**Any Device, Total Control**

From PC to mobile, manage your power plant anywhere and anytime



# Smart Rapid Shutdown Device

AMCL Series - Gen2



- Auto-shutdown to prevent safety issue
- 1V shutdown voltage to ensure DC side safety
- Module-level monitoring to easily locate faulty parts
- Communication distance: 800m to meet various application
- Rotatable installation with bolts and clip allowing full flexibility
- Firmware remote OTA upgrade to continuously improve user experience

Model	AMCL-D2	AMCL-E2	AMCL-F2
<b>Input</b>			
Voltage Range	8-80V Single-channel, 8-120V Dual-channel		
Maximum Input Current	15A	20A	25A
Maximum Short-Circuit Current	30A		
<b>Output</b>			
Voltage Range	8-120V		
Maximum System Voltage	600/1000/1500V		
Maximum Output Current	15A	20A	25A
Maximum Voltage in Disconnect State	1V		
<b>Structure Parameters</b>			
Dimensions (W*D*H)	103*23*105mm		
Input/Output Connectors	MC4/Compatible with MC4/Customizable		
Input Cable Length	PV1: 0.3m(+), 0.6m(-)/0.7m(+), 1.5m(-)/Customizable		
	PV2: 0.3m(-), 0.6m(+)/0.7m(-), 1.5m(+)/Customizable		
Output Cable Length	0.3m(+), 2.7m(-)/Customizable		
Ingress Protection Rating	IP68/Tpye 6P		
Flame Retardant Grade	UL94 5VA		
<b>Environment Parameters</b>			
Temperature Range	-40°C~+85°C		
Relative Humidity Range	0-100%		
<b>Other</b>			
Communication Method	HPLC		
User Interface	WEB+APP		
<b>Certification</b>			
Safety	NEC 2017/2020/2023(690.12), UL1741, CSA C22.2 No.330, UL3741, IEC/EN 62109-1		
EMC	FCC Part15, IEC/EN 61000-6-1/-2/-3/-4		

## System Topology

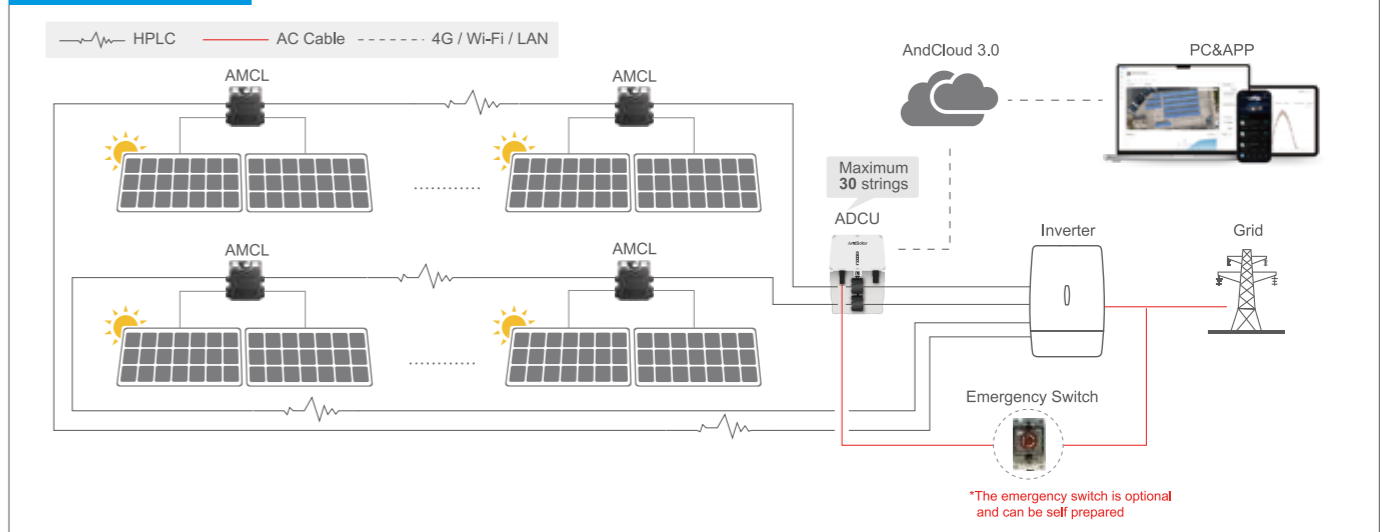

# Smart PV Optimizer

AMCP Series



- Auto-shutdown to prevent safety issue
- Module-level optimization improves system power generation efficiency
- Module-level monitoring to monitor the real-time status of each module
- Smart operation and maintenance reduces power plant O&M costs
- Improve system design flexibility and optimize the usage of building area
- Rotatable installation with bolts and clip allowing full flexibility

Model	AMCP500-600T1	AMCP600-750T1	AMCP1000-1200	AMCP1200-1500
	T1 Series		T2 Series	
<b>Input</b>				
Rated Power	600W	750W	1200W	1500W
Maximum Input Power	650W	900W	1300W	1800W
MPPT Voltage Range	12-80V		24-130V	
Maximum Input Current	15A	22A	16A	22A
Overvoltage Level	II			
<b>Output</b>				
Voltage Range	0-80V		0-130V	
Maximum Output Current	15A	22A	16A	22A
Maximum Voltage in Disconnected State	1V			
Maximum System Voltage	1500V			
<b>Efficiency</b>				
Maximum Efficiency	99.60%			
Weighted Efficiency	99.00%			
<b>Structure Parameters</b>				
Dimensions (W*D*H)	120*33*155mm		120*49*155mm	
Input/Output Connectors	MC4/Compatible with MC4/Customizable			
Input Cable Length	0.7m(+), 1.4m(-)/Customizable		1.4m(+/-)/Customizable	
Output Cable Length	0.3m(+), 1.3m(-)/Customizable		0.3m(+), 2.7m(-)/Customizable	
Ingress Protection Rating	IP68			
<b>Environment Parameters</b>				
Temperature Range*	-40°C~+85°C			
Relative Humidity Range	0-100%			
Highest Altitude	4000m			
<b>Other</b>				
Communication Method	HPLC			
User Interface	WEB+APP			
<b>Certification</b>				
Safety	IEC 62109-1, EN 62109-1, NEC 2017/2020/2023(690.12)			
EMC	IEC/EN 61000-6-1/-2/-3/-4		FCC part 15, IEC/EN 61000-6-1/-2/-3/-4	

\*When the operating temperature exceeds 70°C, the device may work in de-rating mode and return to normal operating mode after the operating temperature decreases;

## System Topology

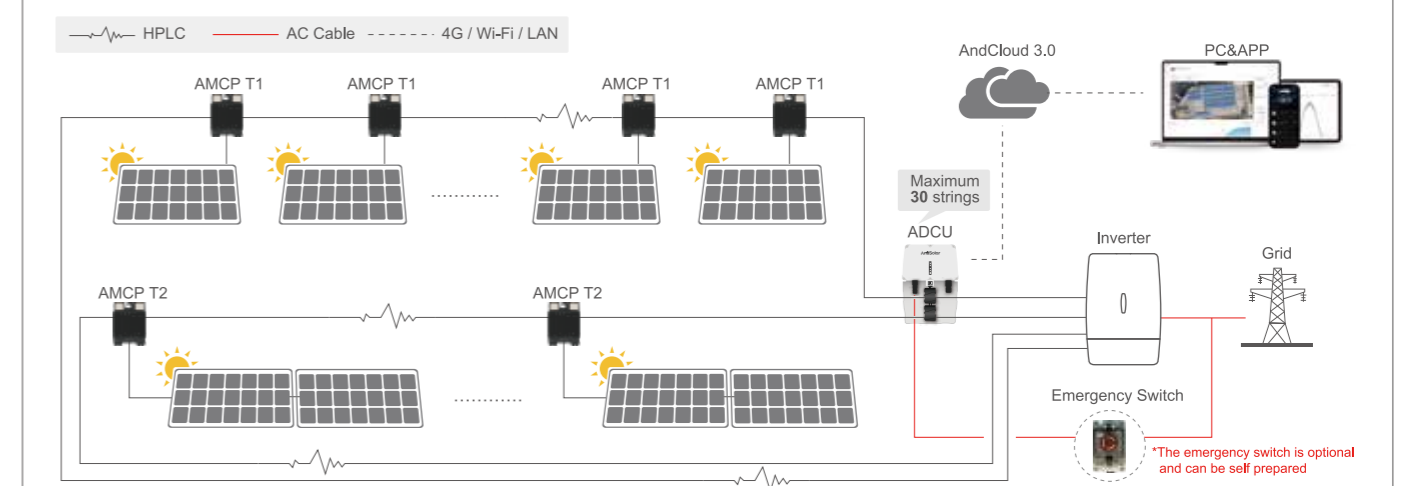

# Gateway

## ADCU Series



-  Support up to 30 PV strings and up to 600 PV modules
-  Innovative compartment design, eliminating the needs to punch holes or cut wires, effortless installation
-  Excellent product design, makes 30% smaller than Gen-1 and enables ingress rating of IP65
-  Support 4G, LAN, Wi-Fi communication methods
-  Equipped with a power switch for easier on-site O&M
-  Support AMCL-Gen2 series and AMCP series in one PV system

Model	ADCU-M0	
<b>Input</b>		
Input Voltage	85-264V AC	
Operating Power	2W	
Maximum MPPT String Voltage	1500V	
Max. No. of Modules in Series	30	
<b>Magnetic Ring</b>		
Number of Magnetic Rings	1	2
Max. Input Strings	10	30
Max. PV Module Input	200(*Specific device)	600(*Specific device)
Thickness	23mm	46mm
Inner Dimension/Outer Dimension	38mm/63mm	
Maximum Current of Single Magnetic Ring	500A	
<b>Outdoor Box Specifications</b>		
Dimensions (W*D*H)	240*101*340mm	
Temperature	-40°C~+85°C	
Ingress Protection Level	IP65	
<b>Communication</b>		
Device Communication	HPLC	
Cloud Communication	4G/LAN/Wi-Fi	
<b>Certification</b>		
Safety	NEC 2017/2020/2023(690.12), UL1741, CSA C22.2 No.330, UL3741, IEC/EN 62109-1	
EMC	FCC Part15, IEC/EN 61000-6-1/-2/-3/-4	

\*Specific device: 1-to-2 devices can input at most 600 modules (e.g., smart rapid shutdown device)

Unit: mm

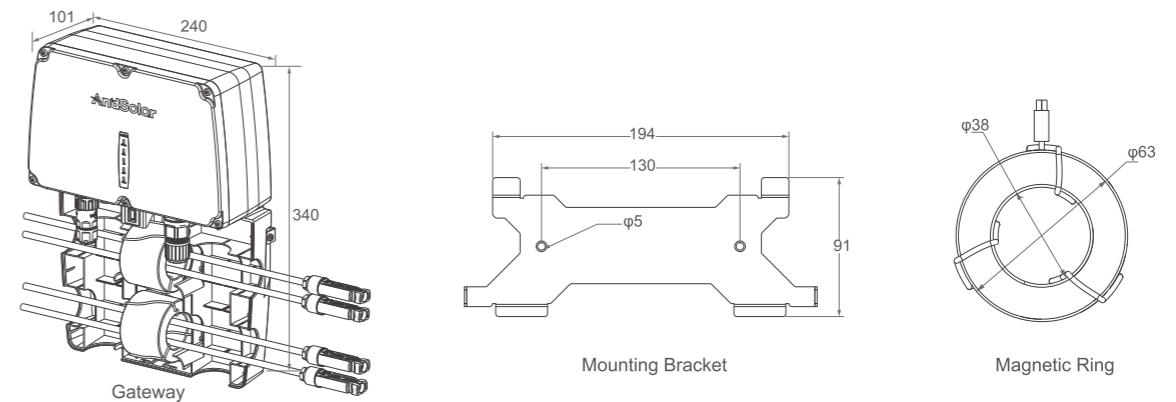



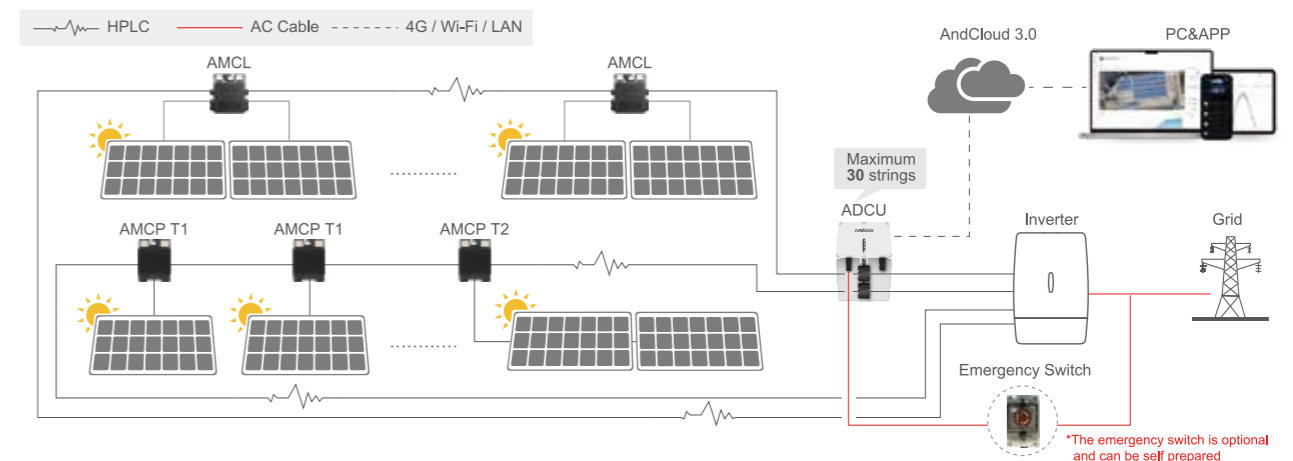



### System Topology



# Smart DC Module

ASSM Series



-  Integrated with smart RSD, more function but less cost
-  Auto-shutdown to prevent safety issue
-  1V shutdown voltage to ensure DC side safety
-  Module-level monitoring to easily locate faulty modules
-  Module-level management to shutdown the faulty module or string
-  Communication distance: 800m to meet various application

\*The Smart DC Module will be released in Q4 2025

Model	ASSM450-460-N54DGS			ASSM620-630-N66DGS		
<b>Mechanical Characteristics</b>						
Cell Type	N- type Mono-crystalline					
No. of Cells	108(54×2)			132(66×2)		
Dimensions	1762×1134×30mm			2382×1134×30mm		
Weight	22.5kg			32.5kg		
Front Glass/Back Glass	1.6mm / 1.6mm			2.0mm / 2.0mm		
Junction Box	AndSolar Smart Box					
Protection Class	Class II					
IEC Fire Type	Class C					
Connector Type	MC4/Compatible with MC4/Customizable					
Output Cables(Including Connector)	(+): 400mm, (-): 300mm/Customized Length					
Ingress Protection Rating	IP68/Tpye 6P					
Flame Retardant Grade	UL94 5VA					
<b>Specifications (STC)</b>						
Maximum Power - Pmax [Wp]	450	455	460	620	625	630
Maximum Power Voltage - Vmp [V]	32.82	33.00	33.17	40.72	40.88	41.02
Maximum Power Current - Imp [A]	13.71	13.79	13.87	15.22	15.29	15.36
Open-circuit Voltage - Voc [V]	39.30	39.50	39.70	49.08	49.28	49.48
Short-circuit Current - Isc [A]	14.48	14.56	14.64	16.08	16.14	16.20
Module Efficiency STC [%]	22.52	22.77	23.02	22.95	23.14	23.32
Power Tolerance	0-+3%					
Temperature Coefficients of Pmax	-0.29%/°C					
Temperature Coefficients of Voc	-0.25%/°C					
Temperature Coefficients of Isc	0.045%/°C					
Operating Voltage Range	8-60V					
Maximum Voltage in Disconnect State	1V					
<b>Application Conditions</b>						
Operating Temperature	-40°C-+85°C					
Relative Humidity Range	0-100%					
Maximum System Voltage	1500V(IEC)					
Maximum Series Fuse Rating	30A					
<b>Other</b>						
Communication Method	HPLC					
User Interface	WEB+APP					

STC: Irradiance 1000W/m<sup>2</sup>, Cell Temperature 25°C, AM=1.5

## System Topology

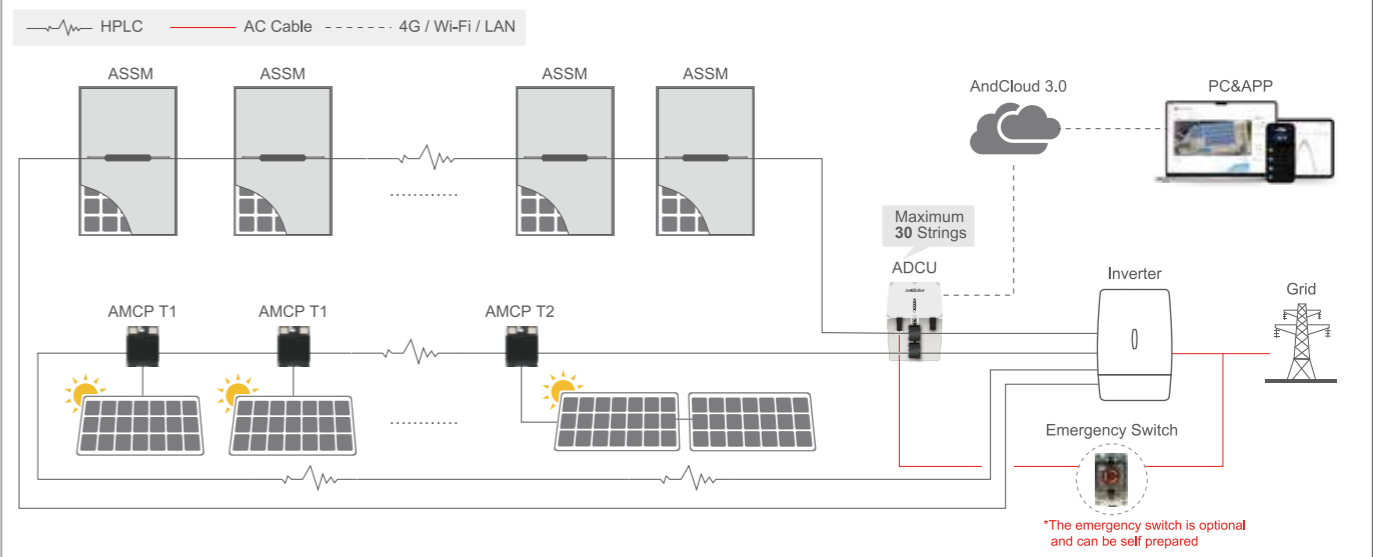





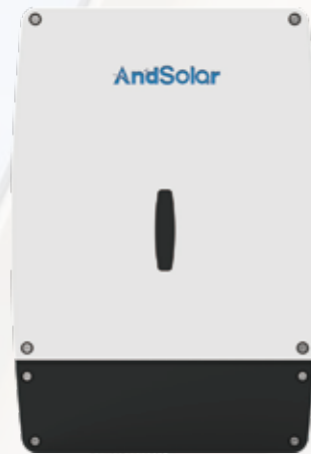

\*The emergency switch is optional and can be self prepared

# Smart Inverter

AECU Series



-  High conversion efficiency improves system power generation capacity
-  To be paired with AndSolar optimizer to maximize system power generation efficiency
-  DC arc fault detection to ensure the safety of power plant
-  Multi-dimensional IV diagnosis and intelligent perception of system problems
-  System-level solutions, collaborative management, efficient and reliable
-  Improve PV power plant O&M efficiency and reduce O&M costs

Model	AECU-A1	AECU-B3
<b>Output</b>		
Rated Output Power	10kW	33kW
Rated Output Voltage	220/230V	380/220V; 400/230V
Maximum Output Current	48A	50A
Grid Type	Single Phase	Three Phase 3W+PE; 3W+N+PE
Rated Frequency	50/60Hz	
Power Factor	-0.8-0.8	
THDi	< 3%	
<b>Input</b>		
Maximum Input Voltage	480V	1000V
Maximum Input Current	25.5A	43.5A
<b>Mechanical</b>		
Dimensions (W*D*H)	350*170*350 mm	350*200*550 mm
Input Connectors	MC4/Compatible with MC4	
Temperature Range	-40-+60°C	
Ingress Protection Rating	IP65	
<b>Other</b>		
Communication Modes	RS485; Wi-Fi; 4G(Optional)	
Maximum Efficiency	98.5%	98.9%
Weighted Efficiency	98.0%	98.5%
<b>Certification</b>		
Safety	IEC/EN 62109-1/-2	
EMC	FCC Part15, IEC/EN 61000-6-1/-2/-3/-4	

## System Topology

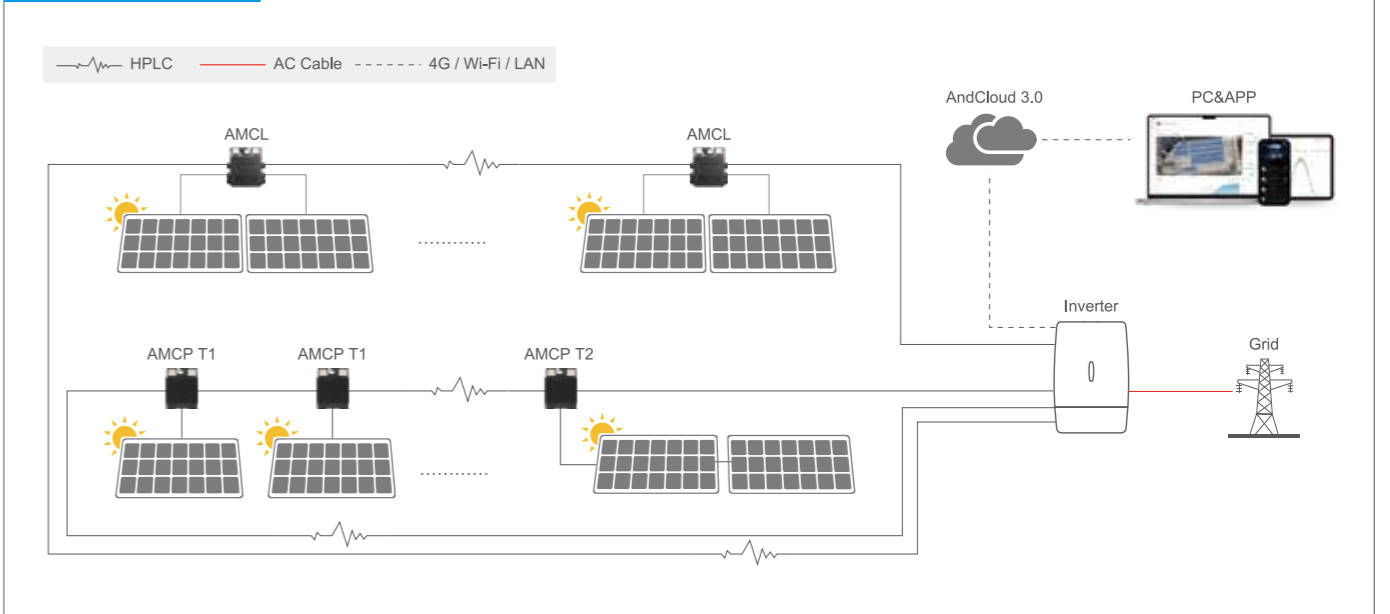

# Service and Support



## Full life cycle reliable service and professional support



### Professional pre-sales

- Sales+Engineer 2V1 pre-sales consultation, answering technical questions about power plant installation
- Accurate and fast assessment, providing a demand list based on the customer's installed capacity



### Installation support

- Global projects with on-site installation guidance and trouble-shooting
- Engineers assist in construction to ensure the precise management of power plant



### Worry-free after-sales service

- Continuous OTA updates of product functions to keep investment rising
- 24/7 real-time service response to efficiently solve customer problems
- All products have been insured by Ping An Insurance



### Professional training

- Professional engineers provide regular training to explain the key points of power plants
- Integrate training forms with online, offline, and simulated operations



**Armstrong Flooring Factory PV Project in Chon Buri, Thailand 10MW**

This 10MW ultra-large PV project is fully equipped with AndSolar smart rapid shutdown device and works with the AndCloud 3.0 to achieve precise 1:1 module-level localization, which not only significantly improves the safety, but also reduces O&M cost, setting an efficient and safe benchmark for large-scale PV projects.



**International Amusement Park in Shanghai, China 5.5MW**

The distributed solar project at Shanghai International Resort adopts AndSolar Smart Rapid Shutdown Devices and complies with the NEC rapid shutdown requirements. While ensuring PV system safety, the project also enables module-level precise management through the AndCloud 3.0. Its successful deployment demonstrates strong recognition of AndSolar's products and technology by a leading global brand.

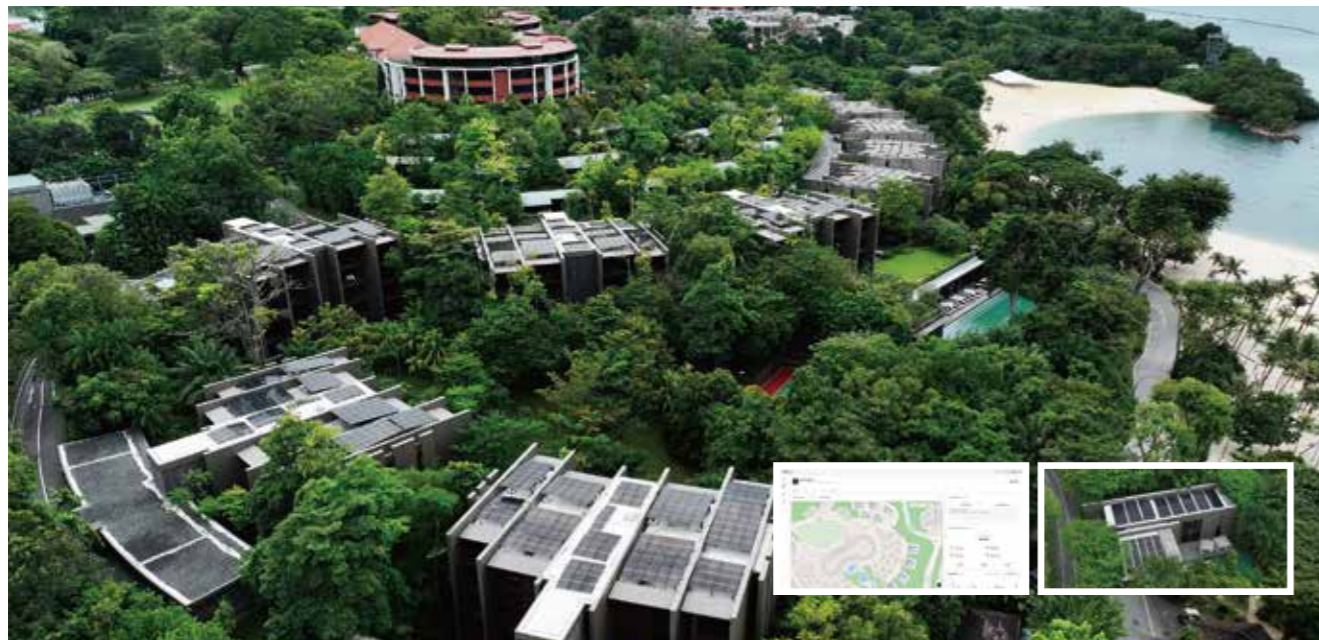

**Capella Resort PV Project in Singapore 249.15kW**

At Capella Resort in Singapore, recognized as one of the world's top 50 hotels, with vegetation across the resort, which creates shading challenges for the rooftop PV system and potential fire safety concerns. The hotel deployed AndSolar Smart Optimizers, improving energy yield under shading while integrating rapid shutdown functionality to ensure safe and efficient operation.

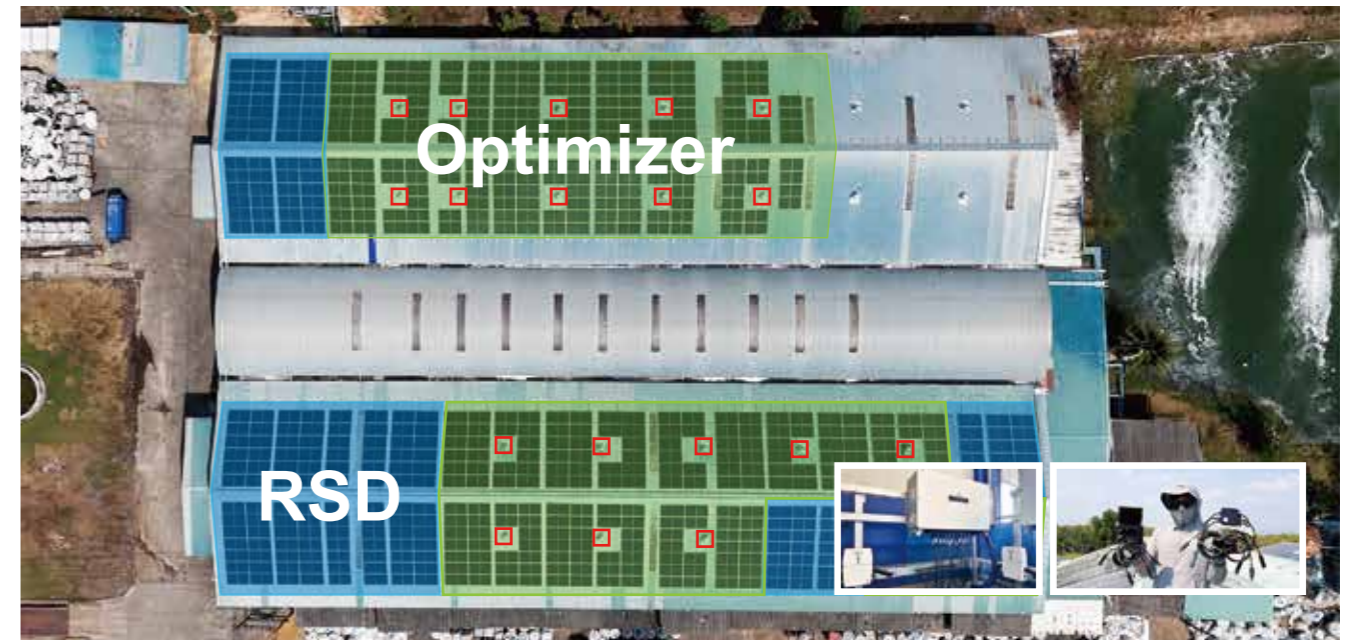

**Plastic Factory PV Project in Prachin Buri, Thailand 431.2kW**

At a plastic recycling factory in Thailand, a complex rooftop PV system faced significant shading and layout constraints. AndSolar deployed a hybrid installation of RSD + Optimizer — RSD in unshaded areas and Optimizers in shaded zones. As the industry-first to enable such hybrid deployment, AndSolar help projects harvest more energy with lower system investment cost.



| MG Stationery in Shanghai, China **5.5MW**



| Electronic Factory in Fujian, China **1066.83kW**



| 3E Industrial Complex in Jiangsu, China **204kW**



| Jotun Carport in Jiangsu, China **494.76kW**



| Shijia Electric Factory in Henan, China **562.84kW**



| SANY PV Project in Hunan, China **1.5MW**



| Tieta Base Station in Jiangxi, China **12kW**



| Orient Pharma Pharmaceuticals in Taiwan, China **499.96kW**



| Subdistrict Office in Shanghai, China **200kW**



| Tianheng Flax in Heilongjiang, China **800.28kW**



| Fudi Villa in Shanghai, China **28.6kW**





| KMITL University in Bangkok, Thailand 6.5MW

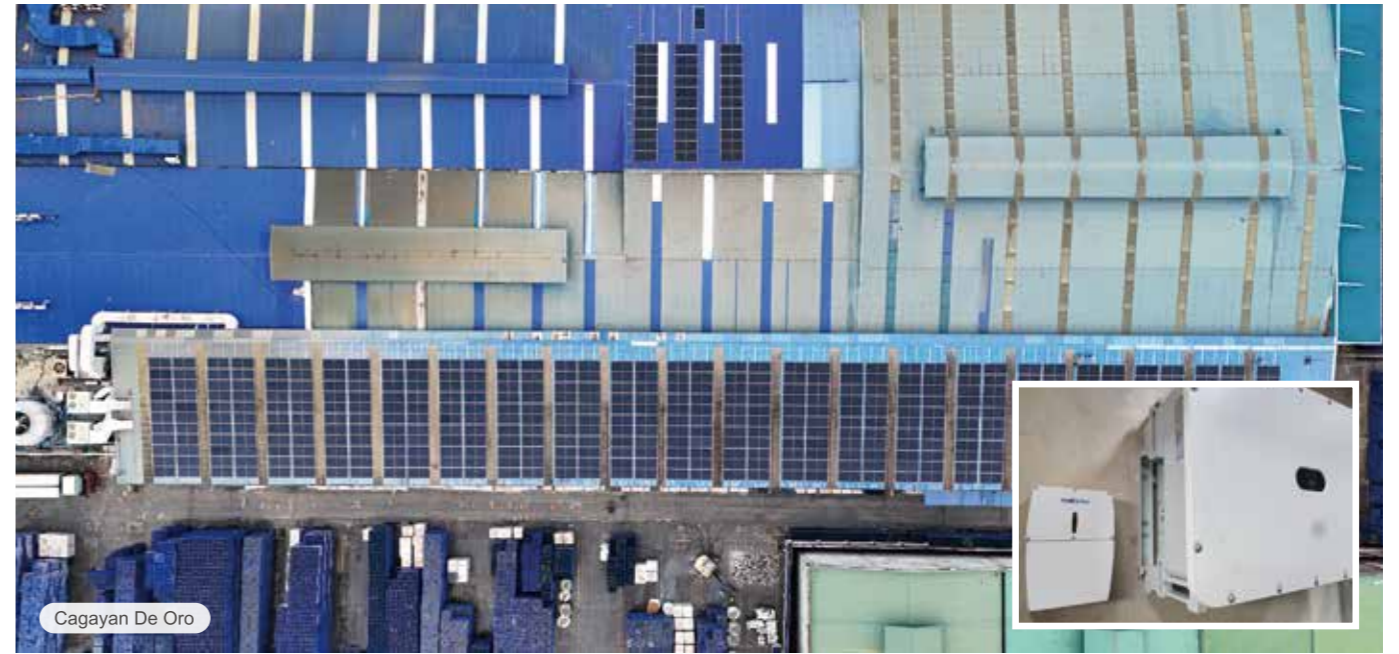

Cagayan De Oro



| Rubber Factory in Krabi, Thailand 2MW



| Hospital Carport in Chon Buri, Thailand 632kW



Iloilo



Bacolod

| Pepsi-Cola Products Philippines, Inc. (PCPPI) Factory, Philippines 3.7MW



| Tool Factory in Rayong, Thailand 400kW



| Agro-Products Factory in Penang, Malaysia 999.44kW



| Global Plaza Mall in Pampanga, Philippines 923kW



| Villa in Sydney, Australia 12.28kW

