



User Manual

Smart Rapid Shutdown System



Table of Contents

Preface	3
Disclaimer	4
1. Precautions	5
1.1. Marking Definitions	5
1.2. General Notes	5
1.3. Environment Requirements	7
1.4. Storage Instructions	7
1.5. Unboxing and Inspection	7
1.6. Product Installation	8
1.7. AMCL Electrical Connection Precautions	8
1.8. Operation	9
1.9. Maintenance and Replacement	9
2. Product Introduction	10
2.1. Smart RSD AMCL	10
2.2. Gateway ADCU Kit	11
3. System Topology Diagram	11
4. Smart RSD AMCL Installation	12
4.1. Product Introduction	12
4.2. Installation Method	13
4.3. Cable Installation	15
4.4. Paste QR Code onto the Physical Layout Template	17

5. ADCU Outdoor Kit Installation	18
5.1. Product Introduction	19
5.2. Installation Procedure	20
6. Product Specifications	24
6.1. AMCL Parameters	24
6.2. ADCU Parameters	26
7. Frequently Asked Questions (FAQ)	27

Preface

Dear customer, thank you for choosing the products of AndSolar Technology Co., Ltd.(Hereinafter referred to as “AndSolar”)! Please be sure to read this User Manual carefully before using this product. By reading this manual carefully, you will have a better understanding of the characteristics of this product, correctly use and maintain this product, ensure safe use and give full play to the best performance of this product, so as to obtain the maximum use benefit.

The pictures provided in this manual are for demonstration purposes only. The detailed information varies slightly according to the product version and market region. This manual is compiled based on the status of the product series at the time of production. The product appearance and technical specifications may continue to evolve. After the product is updated, this manual will be revised accordingly without further notice.

To ensure your installation experience and a smooth installation, we recommend that you scan the QR code below for assistance before starting to install this product.



Disclaimer

AndSolar reserves the right to change the product specifications and this user manual without prior notice. It is recommended to refer to the latest products information and documents on AndSolar's official website (www.andsolartech.com). Since the use of this manual and the conditions of product installation, operation, use and maintenance are beyond the control of AndSolar, AndSolar does not assume any responsibility for any losses, damages or expenses caused by installation, operation, use or maintenance. If the device fails due to your negligence, improper use, etc., you will lose the warranty right; any direct or indirect warranty application caused by this will not be accepted by our after-sales service.

AndSolar does not assume any responsibility for infringement of patents and third-party rights that may result from the use of smart rapid shutdown AMCL (hereinafter referred to as "AMCL" or "RSD") products, smart PV optimizer AMCP (hereinafter referred to as "AMCP" or "optimizer") products, and gateway ADCU (hereinafter referred to as "ADCU" or "gateway") products. Customers do not obtain any patent or patent right authorization, whether express or implied, by using AndSolar products. The information in this manual is based on AndSolar's knowledge and experience that is considered reliable, but such information and related suggestions, including but not limited to the above product specifications, do not constitute any warranty terms, whether express or implied.

The copyright of this manual belongs to AndSolar Technology Co., Ltd. It shall not be disseminated in electronic, mechanical recorded or any other way without the permission and authorization of our company.

1. Precautions

1.1. Marking Definitions

⚠ Danger

Indicates that it may trigger high-voltage electric shock or discharge accidents, which may cause serious harm to the human and property, such as causing personal injury or death or fire accident.

⚠ Warning

Indicates that it may trigger a high-voltage electric shock or discharge accident, which is moderately harmful to the human and property, such as causing a brief electric shock to a person or partially damaging asset.

⚠ Notice

Indicates practice that might damage the RSD product, or products that are electrically connected to the RSD.

Attention

Indicates important information about the product. Failure to comply may result in rework or failure to fully function properly.

1.2. General Notes

This manual contains important instructions for the installation and maintenance of the product smart rapid shutdown device AMCL and gateway ADCU. Please read all instructions and warning signs before installing or using the AMCL system. Failure to follow the instructions or warnings in this manual may result in personal injury or death, damage to the system, and void the warranty.

⚠ Danger

Please perform all electrical installations in accordance with local codes.

When working on site, please ensure that you wear the correct protective gear.

Do not attempt to perform installation, maintenance, replacement or other on-site operations in inclement weather.

▲ Warning

To reduce the risk of injury, read all instructions.

If there is physical damage on the surface of the AMCL, do not operate it directly. Check whether the existing cables and connectors are normal. Do not operate if the wiring or connectors are damaged.

▲ Notice

Installation must be performed by trained professionals. AndSolar is not responsible for product failure or damage caused by incorrect operation, installation or improper use.

Attention

The design and installation of the PV system and PV strings must comply with the relevant requirements of the selected inverter, otherwise it may cause malfunction or failure of the AMCL product.

If AndSolar AMCL and AMCP products are installed in the same system, please ensure that all PV modules connected to the same MPPT of the inverter are connected to only the same type of products. Using multiple types of products under the same inverter MPPT may cause malfunction or failure of the product.

In the same system, other brands of rapid shutdown devices, optimizers or other types of photovoltaic module-level power electronics (MLPE) products should not be used at the same time, otherwise it may cause malfunction or failure of the product.

PV strings connected to the same MPPT shall use modules of the same model and quantity.

1.3. Environment Requirements

- (1) Do not place the device in flammable or explosive environments. Any operation under such conditions is strictly prohibited.
- (2) Do not store the device near open flames or heat sources such as heaters, fire, or other heating equipment. Exposure to heat may damage the device or cause a fire.
- (3) Install the device away from areas with liquids. Do not install the device beneath air outlets, water pipes, or any areas prone to condensation. Avoid installation under air conditioning vents, exhaust outlets, or any locations where water leakage may occur, to prevent liquid from entering the device and causing malfunction or short circuits.
- (4) Do not install the device in environments with direct sunlight, smoke, dust, corrosive gases, volatile gases, organic solvents, excessive salinity, or radiation such as infrared rays.
- (5) Do not install the device in environments containing conductive metallic dust or magnetic dust.
- (6) Do not install the device in locations where it may be submerged in water.

1.4. Storage Instructions

- (1) The storage area should be kept dry to prevent moisture, direct sunlight, and ensure proper waterproof(rainproof) protection.
- (2) Do not place or stack any other items on top of the packaging boxes.
- (3) Products should be arranged neatly with sufficient safety clearance.

1.5. Unboxing and Inspection

▲ Warning

Check all safety signs and product labels to ensure they are clearly visible and not obscured.

After unpacking, check whether the AndSolar smart RSD product (AMCL) is damaged and whether it is the product model ordered. If you find the above problems, do not proceed with the installation and contact customer service

immediately.

1.6. Product Installation

⚠ Danger

Please perform all electrical installation in accordance with local electrical codes.

Ensure that no electrical connections are made prior to product installation.

Before completing the installation of all AMCL products, please ensure that all ADCU products remain uninstalled or powered off, and that PV strings are not connected to the inverter.

Do not attempt installation in inclement weather.

1.7. AMCL Electrical Connection Precautions

⚠ Notice

Please pay attention to the following matters in this section when making electrical connections of AMCL, otherwise it may cause damage to the AMCL product and void the official warranty.

- (1) Please do not short-circuit the AMCL output port, otherwise AMCL will be damaged.
- (2) When installing AMCL, please first connect the PV modules to the AMCL input port, and then connect the output ports of two adjacent AMCL in series. Please do not use the AMCL input or output port incorrectly, such as connecting PV modules to the output of AMCL or connecting the input port of AMCL to the string DC line; If the AMCL is damaged due to incorrect wiring, this is not covered by AndSolar warranty.
- (3) If you need to disconnect AMCL, please disconnect the adjacent AMCL output port first, and then disconnect the input port which connect AMCL to PV module.
- (4) If you need to connect AMCL to a single PV module, you need to connect the PV module to the input 1 (**Module 1**) port of AMCL, and plug the positive and negative connector of the other input port (**Module 2**) directly

into each other.

- (5) Do not use AMCL with different types of DC terminals, otherwise it may cause damage to AMCL and this damage is not covered by the warranty.
- (6) Before disconnecting the AMCL wiring, please use a clip-on ammeter to confirm that AMCL is in a no-current state.(After disconnecting the PV system power supply, the capacitors inside the inverter may remain charged for several minutes. If it is necessary to check or disconnect the system wiring, first measure the voltage at the inverter input terminals to confirm that the capacitors have been fully discharged before disconnecting the connections. When the system enters the rapid shutdown state, wait until the current has completely dropped to a safe level before disconnecting the PV string DC wiring or switching off the DC circuit switch.)
- (7) When AMCL is not connected to other devices, do not expose its terminals to direct sunlight or rain.

1.8. Operation

⚠ Danger

When the product is working, it is prohibited to plug or unplug any connectors on the product.

When the product is running, please do not disassemble any parts, as there is a risk of electric shock.

⚠ Warning

Please do not touch the product's surface when it is working to prevent burns.

1.9. Maintenance and Replacement

⚠ Warning

If there is physical damage on the surface of the AMCL, do not operate it directly. Check whether the existing cables and connectors are normal. Do not operate with damaged wiring or connectors before ensuring the system is

safely shut down, as this may result in electric shock.

Do not remove the casing, disassemble, or attempt to repair the product. This product contains no user-serviceable parts. In case of failure, please contact AndSolar after-sales service. Unauthorized disassembly or damage to the product will void the warranty.

▲ Notice

When replacing an AMCL, please disconnect the adjacent AMCL output first. Before that, do not disconnect the PV module from the AMCL.

Attention

To ensure the continuous and reliable operation of the rapid shutdown function, please perform periodical shutdown test (one test per month is suggested) to verify the normal functioning of the system shutdown capability. The test can be executed either by triggering the on-site emergency switch or by issuing a remote shutdown command through the cloud platform.

The installer team can put plastic or stainless steel casing on the photovoltaic wires to protect the insulation layer on the surface to protect it from accidental damage.

2. Product Introduction

2.1. Smart RSD AMCL



- (1) Compliance with NEC 2017/2020/2023 (690.12) requirements.
- (2) Rapid Shutdown Method : emergency switch manual shutdown, App

remote shutdown, high temperature automatic shutdown.

- (3) Module-level data monitoring: module voltage, current, power, temperature, etc.
- (4) Bi-directional HPLC for high-speed communication.

2.2. Gateway ADCU Kit



Gateway (ADCU) kit is used in conjunction with the smart RSD AMCL. When the power is turned on, the AMCL is controlled and monitored by the ADCU, and the PV modules are connected to the AMCL. When the power is switched off, the ADCU will turn off, and the AMCL will automatically shutdown the connection between PV modules and DC system. When the ADCU resumes operation, the AMCL starts and resumes module access. This solution complies with NEC 2017/2020/2023(690.12) specifications.

3. System Topology Diagram

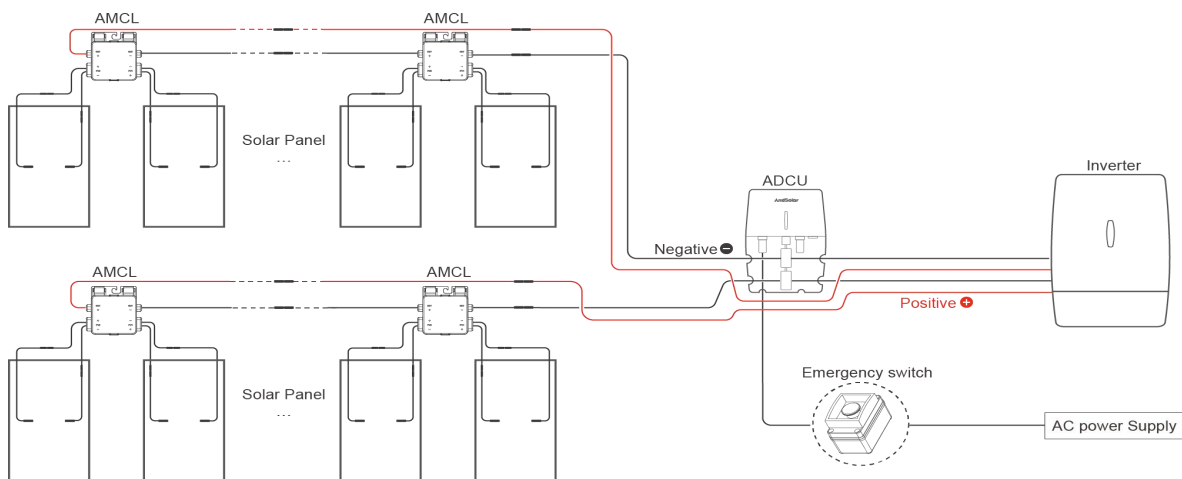

4. Smart RSD AMCL Installation

⚠ Warning

Please ensure that there are no electrical connections before installing the product.
Do not attempt installation in inclement weather.

Attention

Before installing the product, confirm that the installation tools used are available and within the maintenance cycle.
Installation, operation and maintenance must be performed by trained professionals. AndSolar is not responsible for product malfunction or damage caused by improper operation, installation, maintenance or improper use.

4.1. Product Introduction

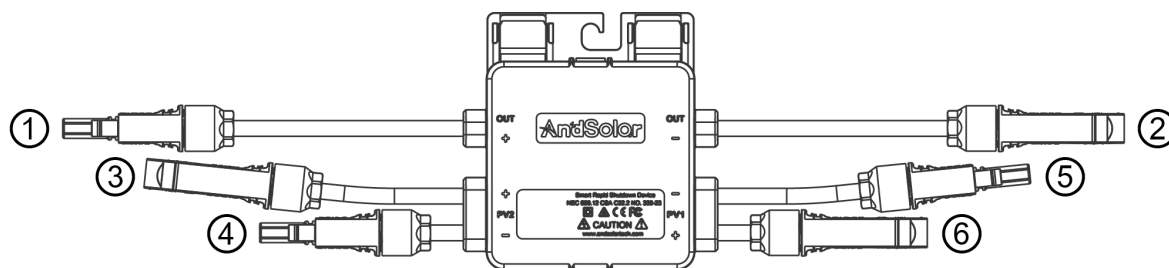

Product Introduction

- ① Output terminal - positive
- ② Output terminal - negative
- ③ Input terminal 2 - positive
- ④ Input terminal 2- negative
- ⑤ Input terminal 1-negative
- ⑥ Input terminal 1-positive

4.1.1. Multi-directional Installation Function

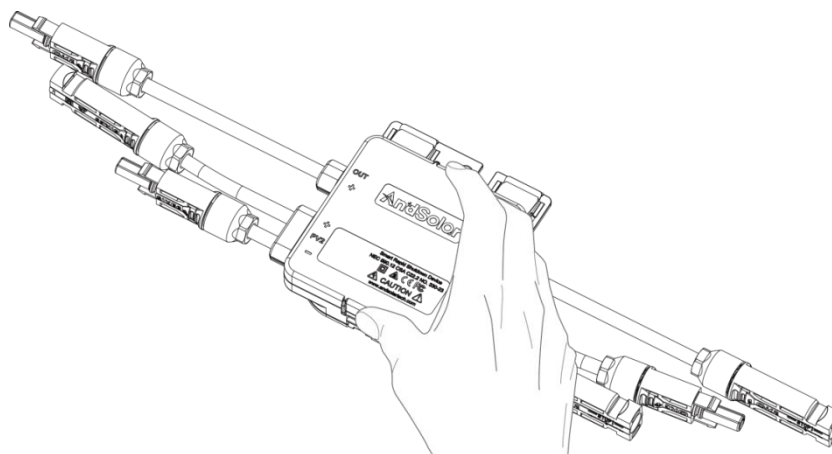

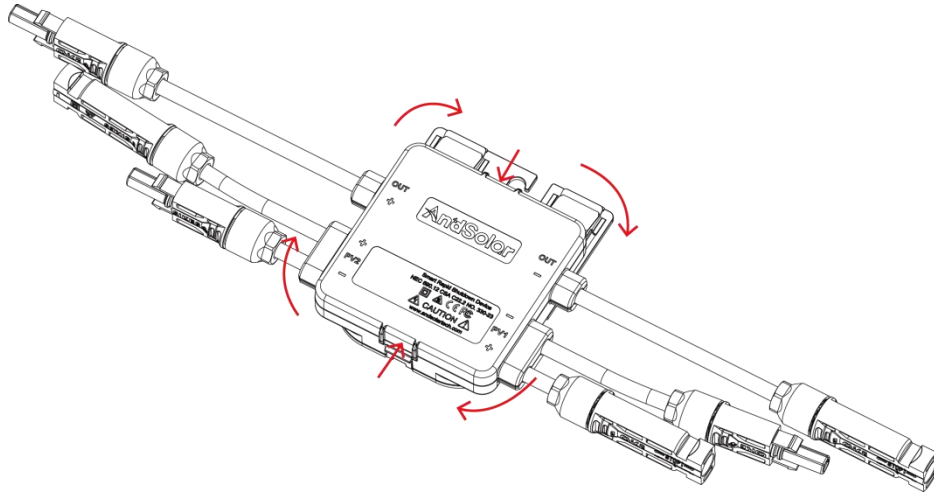

The installation plate features a rotatable design, which is flexible and adjustable, and can realize the multi-directional installation of the AMCL

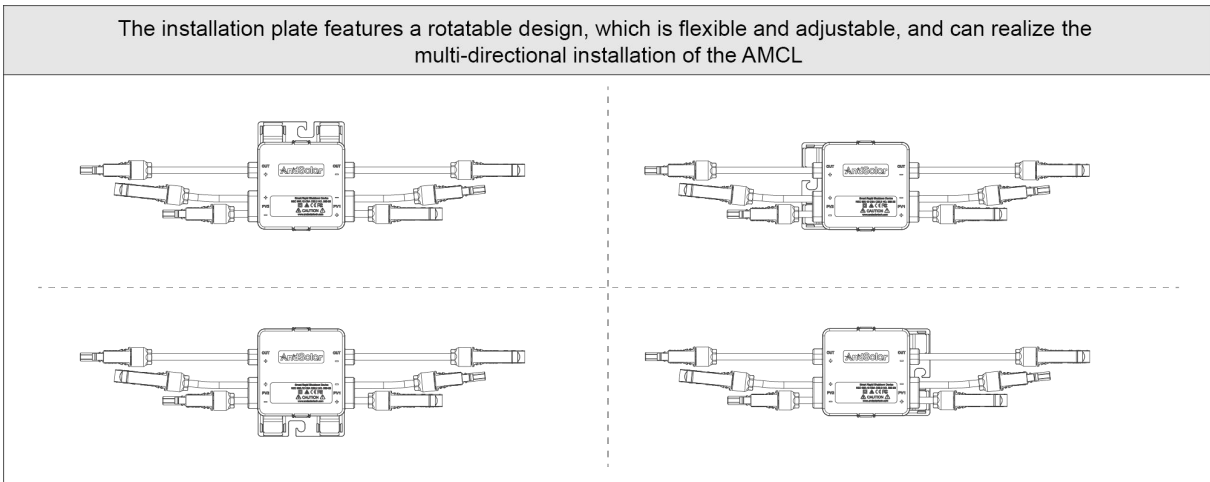

4.2. Installation Method

4.2.1. Clip Installation

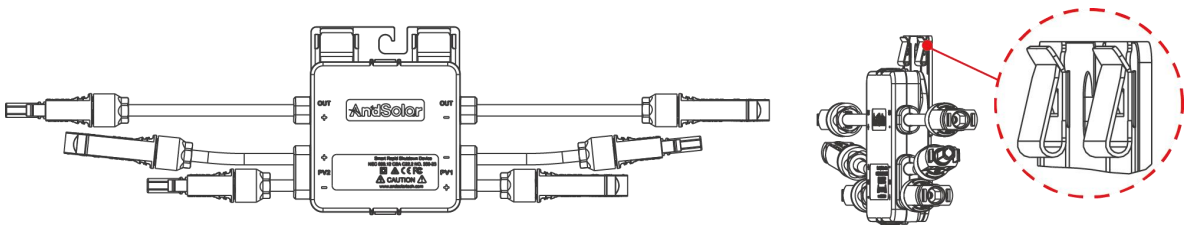

Install AMCL on the PV module frame with the AMCL facing outward.

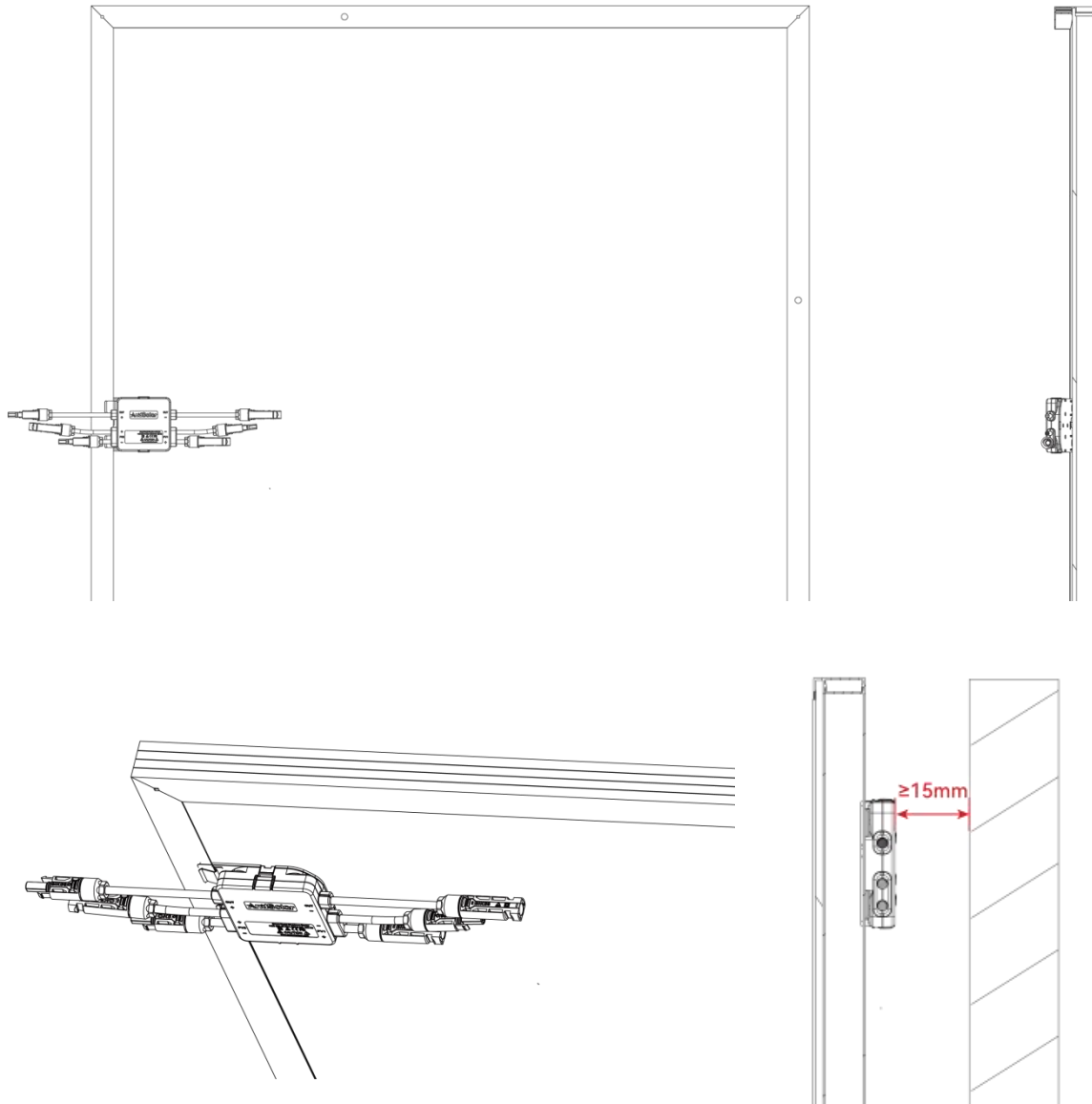

4.2.2. Bolt Installation

Install AMCL on the PV module stand using T-bolts.

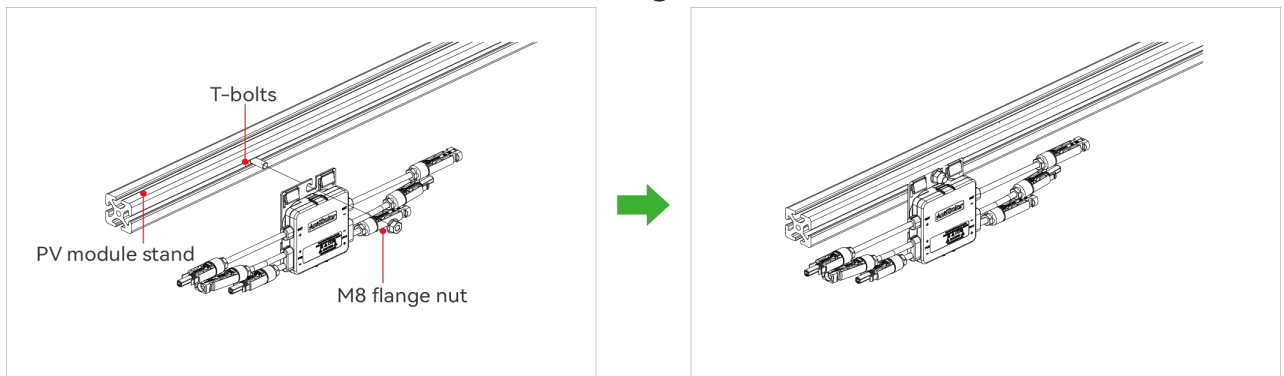

Attention

Regardless of the above installation method, please ensure that the distance between the AMCL surface and the roof, wall or ground is not less than 15mm to ensure sufficient heat dissipation conditions for the device.

4.3. Cable Installation

4.3.1. Cable Connection Requirements

- (1) Do not cover the AMCL housing with DC cables.
- (2) When installing AMCL cables, the bending radius of cables near the housing must be greater than 50 mm. Should the cable's bending radius requirements prove unattainable, rotate the AMCL installation plate.

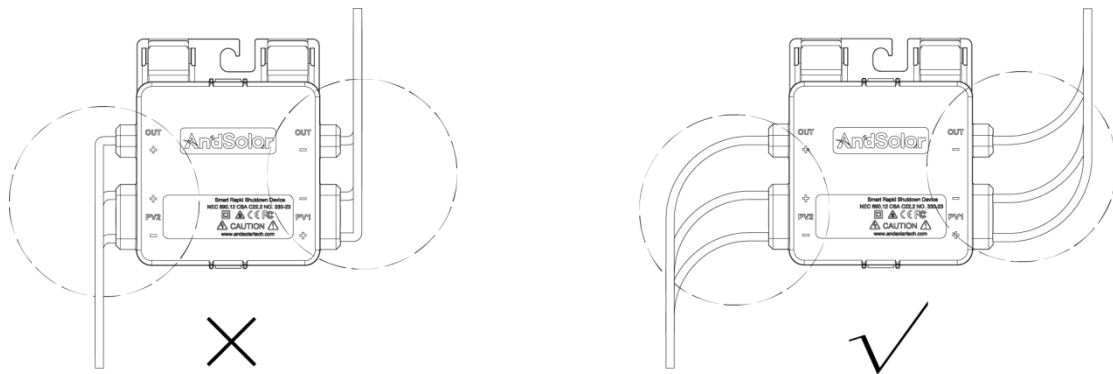

- (3) Refer to IEC 62548-1:2023, Section 7.3.3.3: To reduce EMC interference and ensure communication quality, it is recommended that the positive and negative DC cables of the same string be routed close together (i.e., minimize the distance between the positive and negative DC home-run cables), and the positive and negative DC cables of the same string should be placed within the same cable tray or conduit, avoiding separate routing of the positive and negative home-run cables within the same string. As shown in the installation scenarios of single or multiple strings in the following figure.

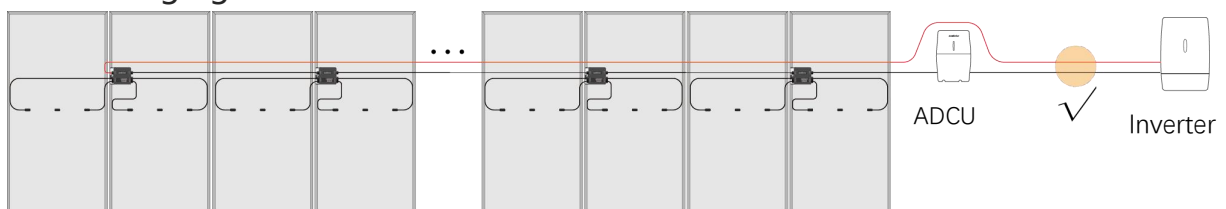

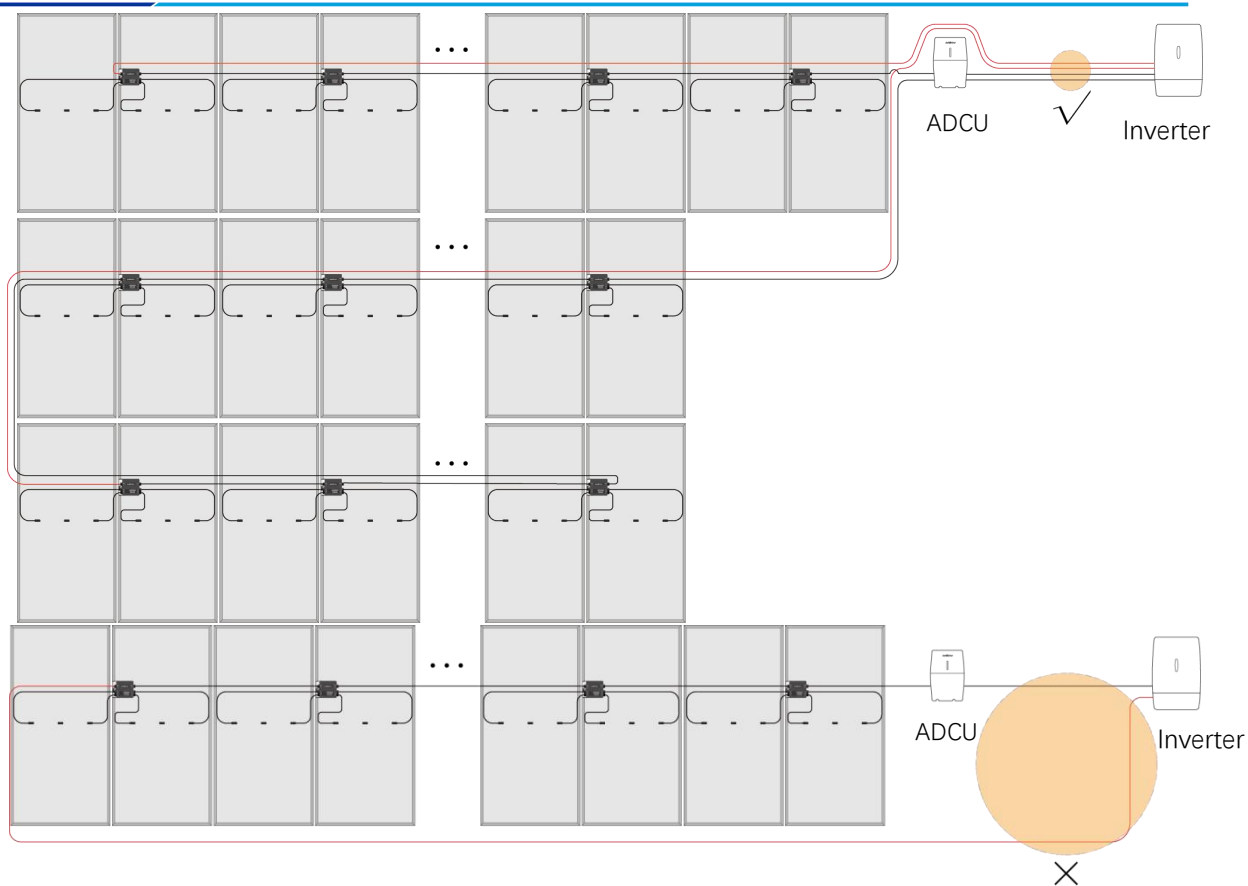

(4) DC and AC cables within the system must be routed in separate trays or conduits and kept at least 10 cm apart.

4.3.2. Connect AMCL and PV Module Cables

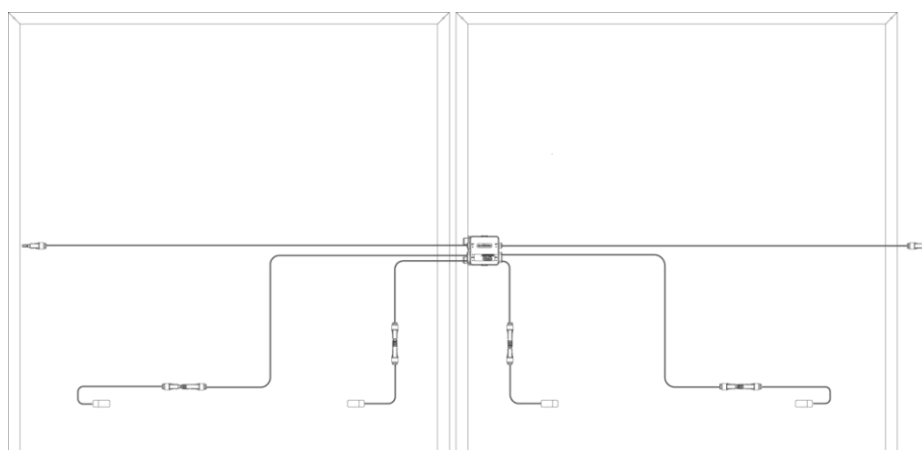

⚠ Danger

Please ensure the inverter and modules are disconnected before connecting cables, otherwise it may cause electric shock.

▲ Notice

The positive and negative terminals of a single PV module must be connected to the positive and negative terminals of **Input-1 (Module 1)** or the positive and negative terminals of **Input-2 (Module 2)** of the RSD respectively. It is not allowed to connect the positive and negative terminals of the PV module to RSD input **Module 1+ / Module 2-** or to input **Module 2+ / Module 1-**, otherwise the product may be damaged. Do not connect PV module to the output terminal of the RSD, otherwise the product may be damaged as well. When using a 1-to-2 AMCL product with only one PV module connected, the module must be connected to the **Input-1 (Module 1)** port of the AMCL. The positive and negative connectors of the cable at the **Input-2 (Module 2)** port should be directly plugged together.

4.3.3. Connect Two adjacent AMCL Output Ports in Series

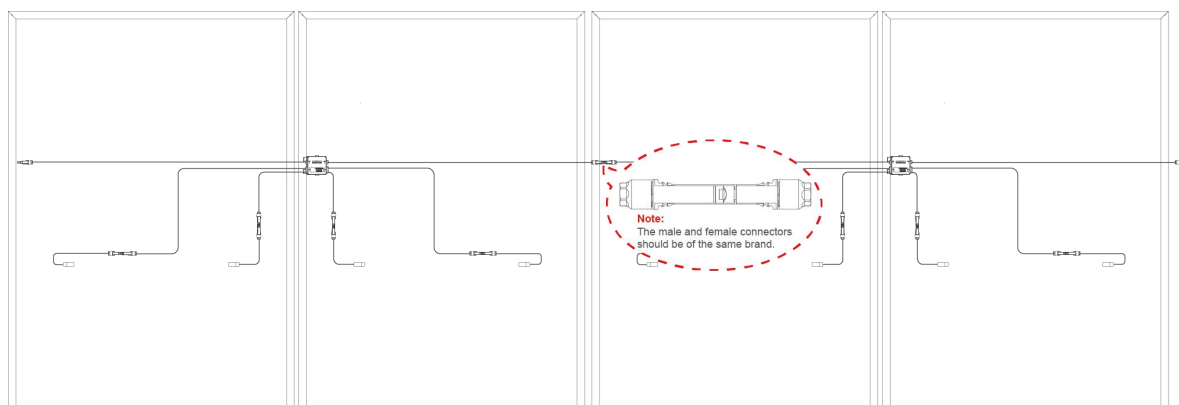

▲ Warning

Please ensure to connect the input of the RSD first, and then connect the output of the RSD, otherwise it may cause an electric shock accident.

4.4. Paste QR Code onto the Physical Layout Template

Determine the appropriate installation position for the AMCL, remove the QR code label from the product label of the AMCL, and then paste it onto the "Physical Layout Template". Please refer to the instructions in the "Physical Layout Template" and attach the QR code label to the layout template.

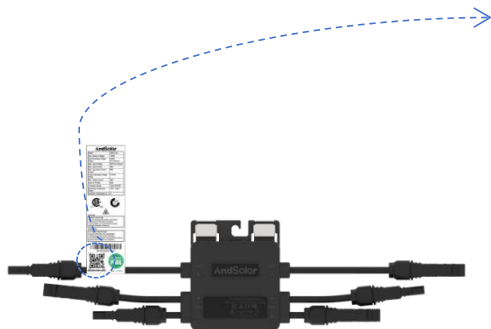

1. Before operation, carefully read the instructions provided in the layout template.

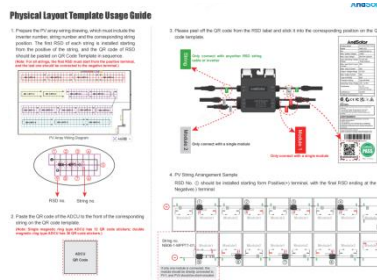

2. Remove the QR code label from the AMCL label, and attach it to the layout template.

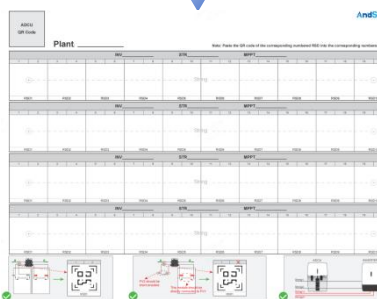

Note:

- (1) Attach the QR code label to the template based on the actual position of the AMCL at the site.
- (2) Keep the QR code label flat and even, and make sure it does not go outside the cell border.

5. ADCU Outdoor Kit Installation

⚠ Danger

When installing the ADCU, please ensure that the AC power input is disconnected from the power grid, otherwise it may get an electric shock.

5.1. Product Introduction

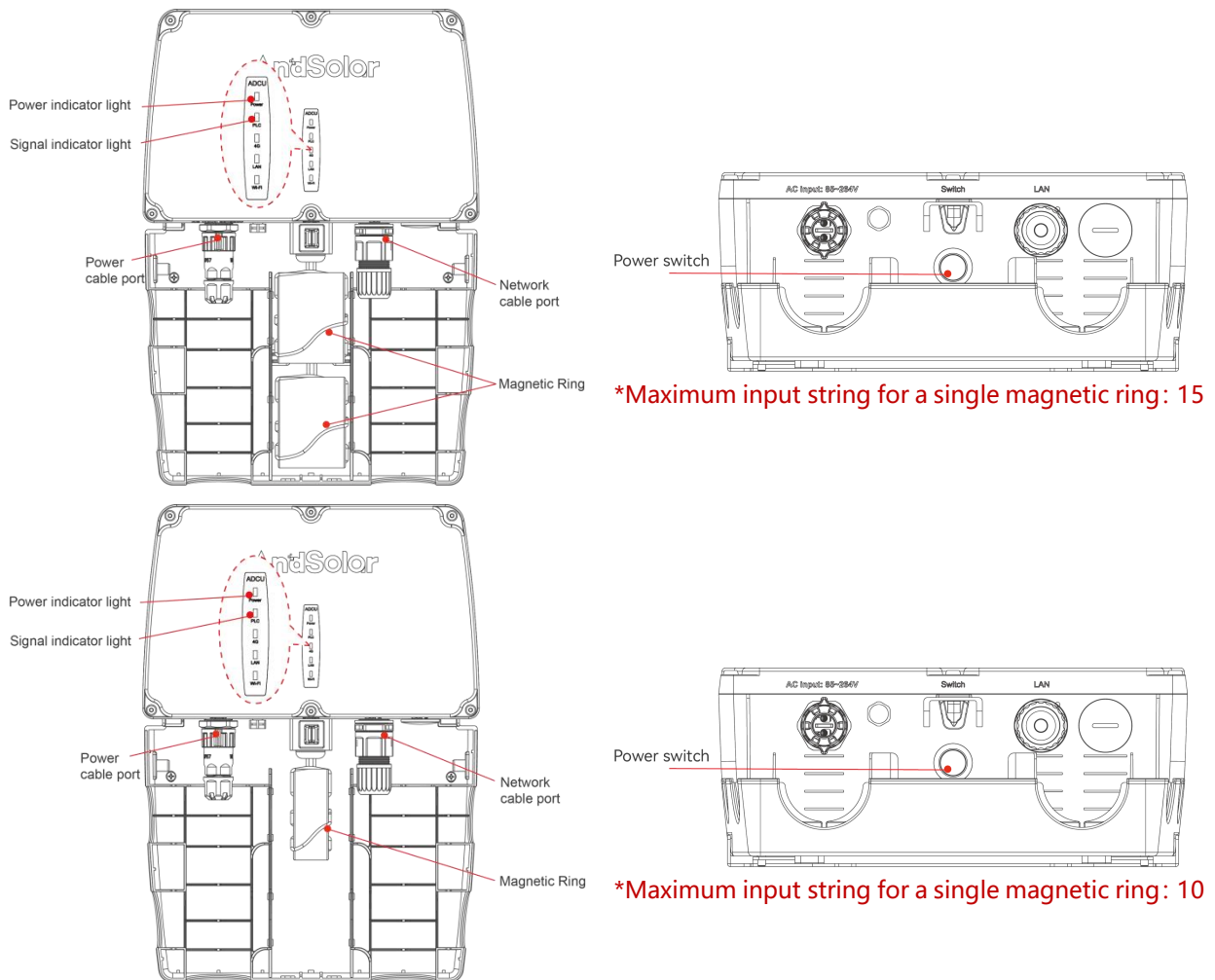

Note :

- (1) The smart RSD AMCL must be used in conjunction with ADCU.
- (2) When powered on, ADCU sends signals to the AMCL units to enable the connection of the PV modules. When switched off, ADCU will turn off, and AMCL units will automatically disconnect the connection between PV modules and DC system. When the power is restored to ADCU, AMCL will resume the PV module operation.
- (3) This solution complies with NEC 2017/2020/2023(690.12) specifications.

Indicator Light Flashing Rule:

- (1) Power indicator light: When the system is running normally, the power LED remains on. If the ADCU is faulty, the LED goes off.

- (2) PLC indicator light: When communicating, the LED signal light flashes; when there is no communication, the LED signal light remains off.
- (3) 4G indicator light: The LED signal light remains off when 4G is disconnected, stays steadily lit when 4G is connected to the server, and flashes during data traffic.
- (4) LAN indicator light: The LED signal light remains off when the Ethernet cable is disconnected, stays steadily lit after being connected to the server, and flashes during data traffic.
- (5) Wi-Fi indicator light: The LED signal light remains off when Wi-Fi is disconnected, stays steadily lit when Wi-Fi is connected to the server, and flashes during data traffic.
- (6) When the PV plant is shut down remotely: the PLC, 4G, LAN, and WiFi lights flashes simultaneously.
- (7) The power station is shut down due to fault warning: PLC and 4G form one group, LAN and Wi-Fi form another group, and these two groups of LED lights flash alternately.

5.2. Installation Procedure

Step 1: After removing the lower compartment cover, use a screwdriver to remove the sheet metal mounting part from the back of the ADCU. Mark the installation holes at the mounting location, drill holes at the marked positions, and secure the sheet metal mounting part using expansion screws. Hang the ADCU onto the mounting part and secure it with the provided screws.

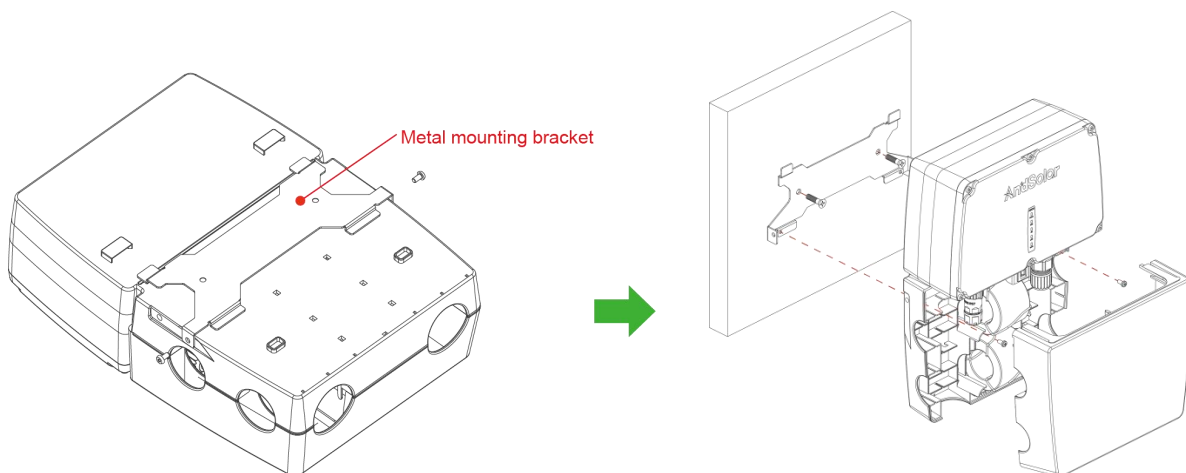

Step 2: Connect the negative DC cable to the inverter through the magnetic ring, and connect the positive DC cable directly to the inverter.

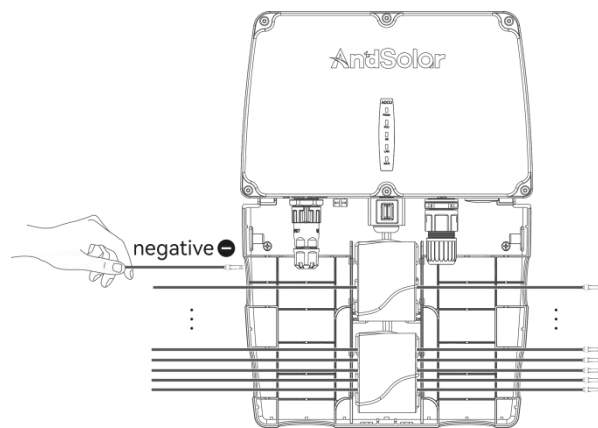
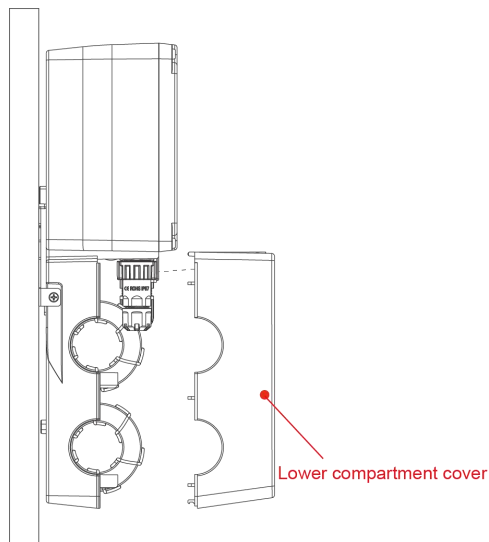

*Maximum input string for a single magnetic ring: 15

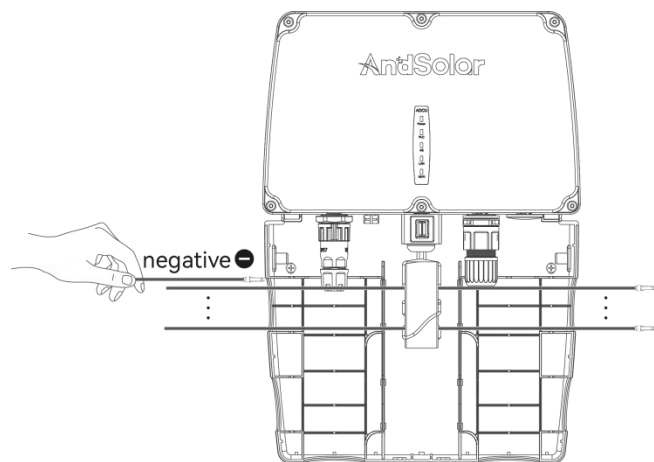
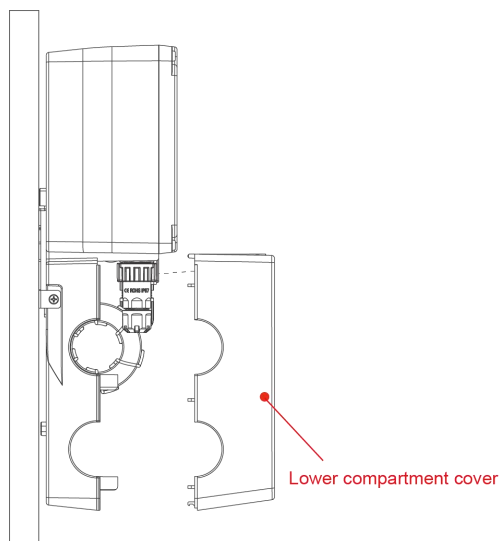

*Maximum input string for a single magnetic ring: 10

Attention

Do not pass the positive terminal of the RSD through the magnetic ring, otherwise it will affect the HPLC communication function of the product and may further cause the PV module to be unable to generate electricity.

All branches under the same MPPT of the inverter should be connected to the same gateway, otherwise it may cause the product to fail to work properly or even be damaged.

Step 3: Connect the power cable to the device through the power cable waterproof connector.

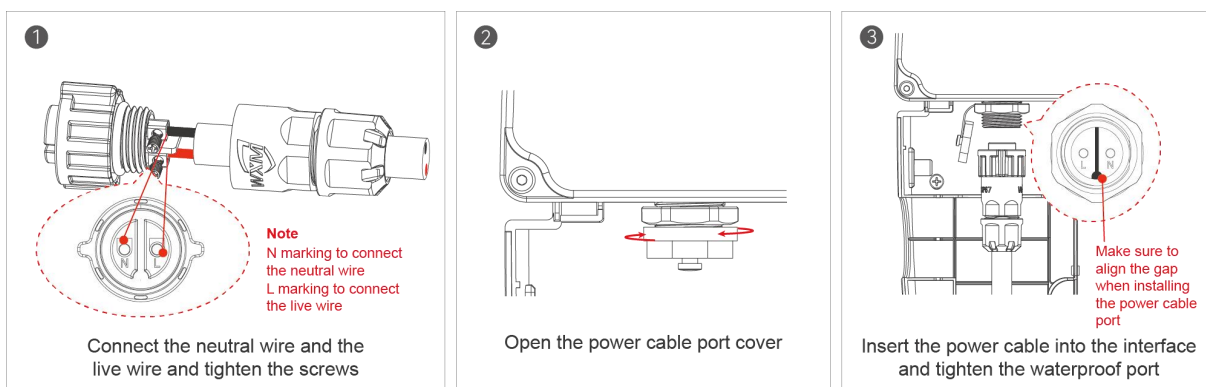

Step 4: Emergency Switch Installation

Install the waterproof connector onto the emergency stop switch; cut the live wire and install the fork terminal.

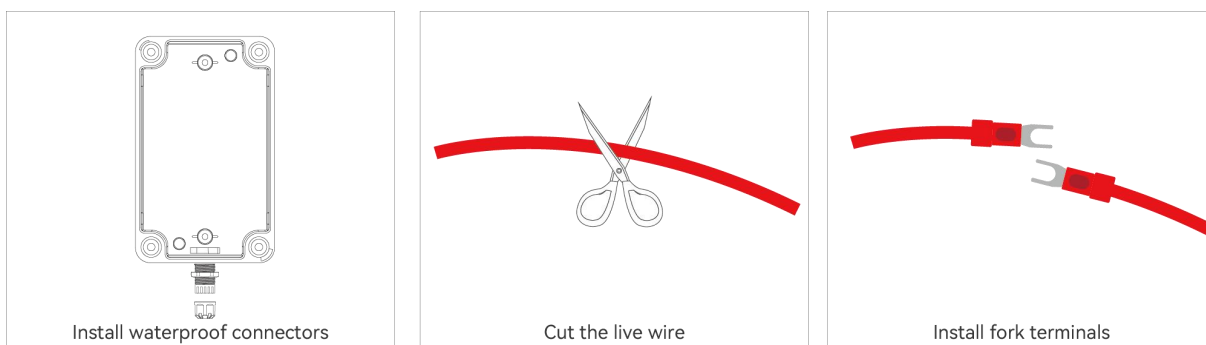

Thread the live wire through the bottom of the waterproof connector on the emergency switch; connect the fork terminals to the red normally closed contacts labeled 11 and 12 respectively; then tighten the screws at both ends of the contacts. After wiring completion, secure the waterproof connector, the fixing bolts of the shell, and install the weatherproof window cover.

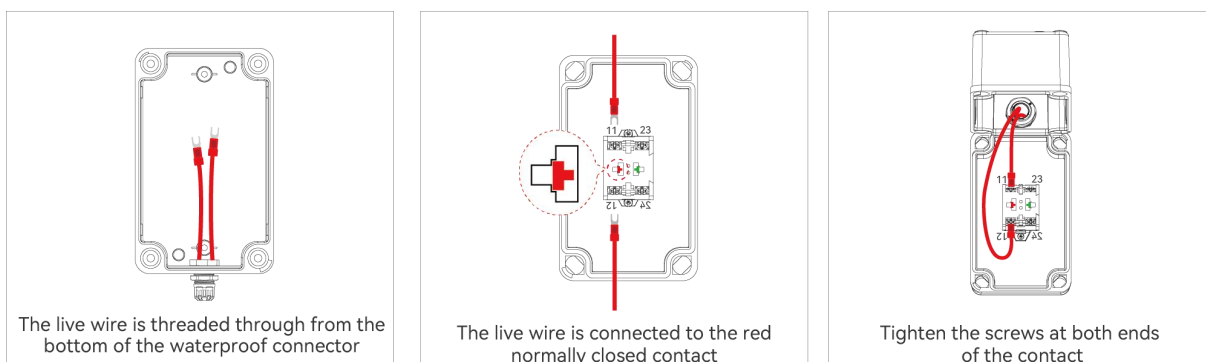

Note:

- (1) The emergency switch is optional. Users can prepare it by themselves.
- (2) The normally closed (NC) contacts are in a conductive state under normal conditions. When the emergency switch is pressed, they disconnect to achieve circuit disconnection (relay protection).
- (3) The installation methods may vary depending on the model of the emergency switch of different types.
- (4) Ensure the waterproof connector, the fixing bolts of the shell, and weatherproof window cover are fully secured to guarantee protective effect.

Step 5: Communication Installation

(1) LAN version: The network cable is connected to the device through the network cable waterproof connector. (applicable to LAN communication version)

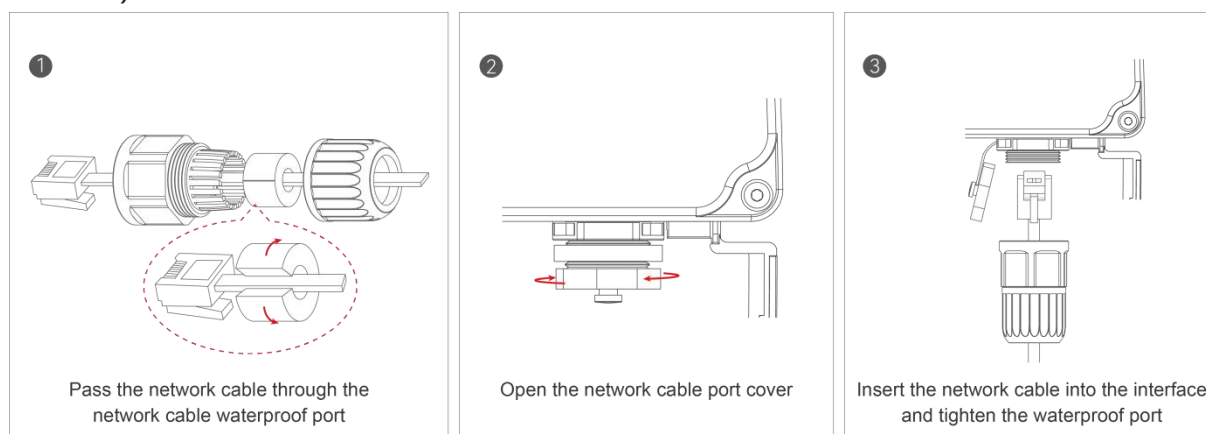

Step 6: After powering on, please turn on the switch to make the ADCU run. Install the lower compartment cover to complete the installation.

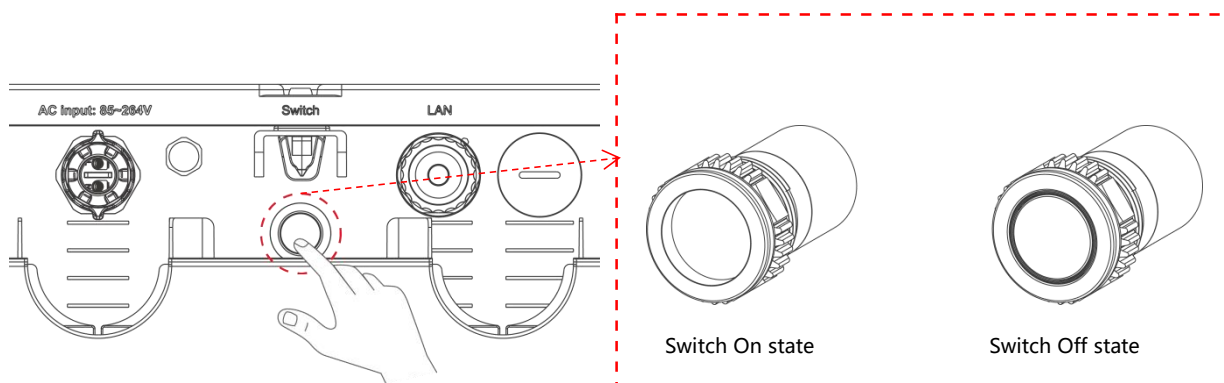

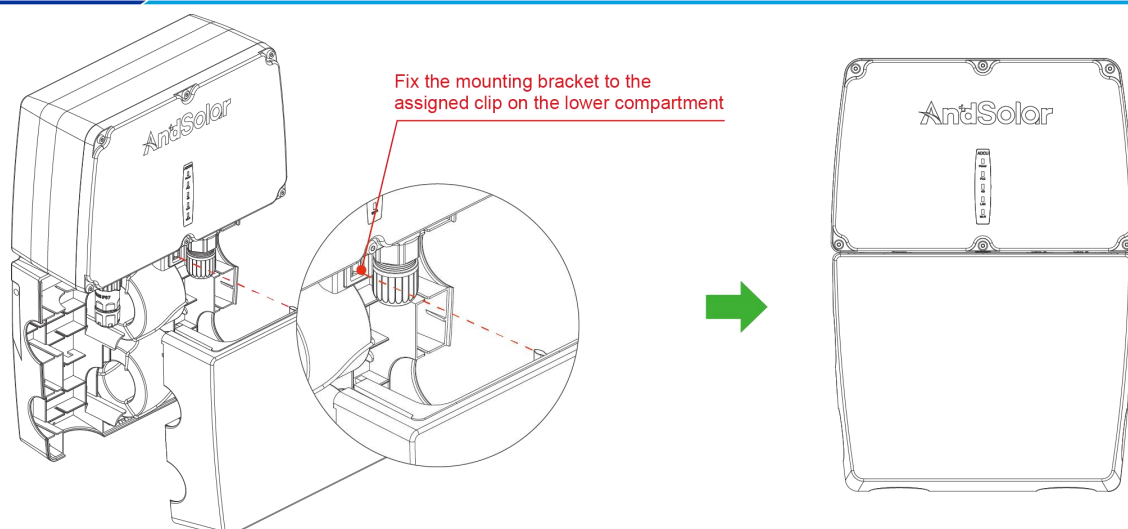

Note:

- (1) Please install the AMCL first, before supplying power to ADCU.
- (2) When the system is running normally, the power LED remains on. If the ADCU is faulty, the LED goes off. If the power LED is off, check whether the power supply is faulty.
- (3) Maximum input string of single magnetic ring: 10/15. (It is recommended that the DC cable diameter be 6.35 mm or less. Larger cable diameters may limit the number of strings due to the physical size constraints of the magnetic ring.)
- (4) Maximum current of a single magnetic ring maximum current: 500A.
- (5) The maximum communication distance between AMCL and ADCU : 800m.
- (6) Recommended ADCU power supply cable: 1.0 ~ 1.5 mm² cable.
- (7) Different branches of the same MPPT of the inverter should be connected to the same ADCU.

6. Product Specifications

6.1. AMCL Parameters

Model	AMCL-D2	AMCL-E2	AMCL-F2
Input Parameters			
Voltage Range	8-80V Single-channel, 8-120V Dual-channel		
Max. Input Current	15A	20A	25A

Max. Short-Circuit Current	30A		
Output Parameters			
Voltage Range	8-120V		
Max. System Voltage	600/1000/1500V		
Max. Output Current	15A	20A	25A
Max. Voltage in Disconnect State	1V		
Structure Parameters			
Dimensions (W*D*H)	103*23*105 mm		
Input/Output Connectors	MC4/Compatible with MC4/Customizable		
Input Cable Length	PV1:0.3m(+),0.6m(-)/0.7m(+),1.5m(-)/Customizable		
	PV2:0.3m(-),0.6m(+)/0.7m(-),1.5m(+)/Customizable		
Output Cable Length	0.3m(+), 2.7m(-)/Customizable		
Ingress Protection Rating	IP68/Type 6P		
Flame retardant grade	UL94 5VA		
Environment Parameters			
Temperature Range	-40°C- +85°C		
Relative Humidity Range	0-100%		
Communication and interconnection			
Communication Method	HPLC		
User Interface	WEB+APP		
Certification			
Function and Safety	NEC 2017/2020/2023(690.12), UL1741, CSA C22.2 No.330, UL 3741, IEC/EN 62109-1		
EMC	FCC Part15, IEC/EN 61000-6-1/-2/-3/-4		

6.2. ADCU Parameters

Model	ADCU-M0	
Input		
Input Voltage	85-264V AC	
Operating Power	2W	
Max. MPPT String Voltage	1500V	
Max. No. of Modules in Series	30	
Max. No. of MLPE Device Series Connections	30	
Max. No. of MLPE Device Parallel Connections	Unlimited	
Max. Shutdown Time	Less than 30s	
Magnetic Ring		
No. of Magnetic Rings	1	2
Max. Input Strings	10	30
Max. PV Module Input	200(*Specific device)	600(*Specific device)
Thickness	23mm	46mm
Inner Dimension/Outer Dimension	38mm/63mm	
Max. Current of Single Magnetic Ring	500A	
Outdoor Kit Specifications		
Dimensions (W*D*H)	240*101*340mm	
Temperature	-40°C-+85°C	
Ingress Protection Rating	IP65	
Communication		
Device Communication	HPLC	
Cloud Communication	4G/LAN/Wi-Fi	
Certification		
Safety	NEC2017/2020/2023(690.12), UL1741,CSA C22.2	

	No.330, UL3741,IEC/EN 62109-1
EMC	FCC Part15 , IEC/EN 61000-6-1/-2/-3/-4

Specific device: 1-to-2 devices can input at most 600 modules (e.g., smart rapid shutdown device)

7. Frequently Asked Questions (FAQ)

Q1: The clip installation method is difficult to install. How to solve the problem?

A1: When installing, the product can be tilted 30°. First, snap one side into place, and then snap the other side into place, which will require less effort.

Q2: When an RSD is connected to two PV modules, how to distinguish PV 1 and PV 2?

A2: The two input ports PV 1 and PV 2 are marked on AMCL products. If the identification cannot be confirmed, you can judge based on the AMCL structure. The port next to the negative electrode of the AMCL output is connected to PV 1, and the port next to the positive electrode of the AMCL output is connected to PV 2. Connecting mistake or recording errors will affect the precise physical location of the module, but will not affect normal power generation and shutdown functions.

Q3: How to ensure on-site construction efficiency?

A3: Recommended installation steps:

(1) After getting the PV module wiring drawing, mark the place where the RSD needs to be installed in advance, print it out and bring it to the site.

(2) After unboxing the RSD, place each RSD according to the position marked on the drawing.

(3) Remove the binding band (if any) on the RSD.

(4) Tear off the QR code on each RSD label as required and stick it on the "Physical Positioning Template" printed in advance.

(5) First, install the input lines. After the input lines installation are completed, install the output lines. When connecting the output lines in series, pay attention to start from the first RSD on the positive terminal of a string, leaving the positive output of this RSD unconnected. Then, connect them in series to the last one in sequence to ensure that the positive and negative terminals of

the entire string are accurate and do not require rework.

Q4: After the RSD is connected in series, why is the measured string voltage 0V?

A4: Regulatory requirements stipulate that RSD default to the shutdown state. After installing the ADCU and supplying power to it, the ADCU transmits HPLC signals through the string's negative cable to the RSD. After receiving the signal, the RSD will switch to the conducting state, and the string voltage can be measured normally at this time.

Q5: Can the AC power supply of the ADCU be taken from the AC side of the inverter nearby?

A5: It is first recommended to use grid electricity or draw power from the grid-connected box. When meeting relevant national and regional requirements or design standards, power can also be taken from the nearest inverter, but a suitable circuit breaker needs to be connected in series with the live wire to ensure that it will not be burned when the circuit fails or is short-circuited.

Q6: Can the RSD be placed on the ground?

A6: The RSD needs to be hung on the PV module in strict accordance with the requirements, or installed on the bracket with screws.

Q7: Can the one-to-two AMCL product be connected to only one PV module to work? How to connect?

A7: Yes. If you want to connect AMCL to a single PV module, you need to connect the PV module to the **Input 1 (Module 1)** port of AMCL, and **plug the positive and negative terminal cables' connectors of the other input port Input-2 (Module 2) directly into each other**, in this case, improper wiring may prevent the device from operating properly.

Q8: Does the inverter need to correspond to the ADCU? What should I do if the number of PV strings supported by the inverter is inconsistent with the number of PV strings supported by the ADCU?

A8: PV strings connected to different inverters and different MPPT can be

connected to the same ADCU. It should be noted that all branches of the same MPPT of the inverter should be connected to the same ADCU.