

CONTROL VALVE

HGZK AUTOMATIC VALVE

HGZK is a full-service enterprise dedicated to the production of control valves, encompassing all aspects from design and manufacturing to sales and maintenance.



CONTENTS

01	Number Description
02	Control Valve Body Type
03	Control Valve Bonnet Type
04	Control Valve Body Material
05	Control Valve Stuffing Box Structure
06	Control Valve connection Method
07	Control Valve Selection
09	Actuator Selection
10	Valve Positioner Selection
11	PCV- <input type="checkbox"/> <input type="checkbox"/> <input type="checkbox"/> <input type="checkbox"/> <input type="checkbox"/> -S1N Precision Small Pneumatic Single Seat Regulating Valve
14	PCV- <input type="checkbox"/> <input type="checkbox"/> <input type="checkbox"/> <input type="checkbox"/> <input type="checkbox"/> -S2D Precision Small Pneumatic Sleeve Control Valve
17	PCV- <input type="checkbox"/> <input type="checkbox"/> <input type="checkbox"/> <input type="checkbox"/> <input type="checkbox"/> -S2N Single Seat Control Valve
19	PCV- <input type="checkbox"/> <input type="checkbox"/> <input type="checkbox"/> <input type="checkbox"/> <input type="checkbox"/> -S1N Caged Single Seat Control Valve
21	PCV- <input type="checkbox"/> <input type="checkbox"/> <input type="checkbox"/> <input type="checkbox"/> <input type="checkbox"/> -S2N Pneumatic Diaphragm Straight-through Single-seat Regulating Valve
22	PCV- <input type="checkbox"/> <input type="checkbox"/> <input type="checkbox"/> <input type="checkbox"/> <input type="checkbox"/> -S3N Precision Small Pneumatic Diaphragm Straight-through Double-seat Regulating Valve
23	P3CV- <input type="checkbox"/> <input type="checkbox"/> <input type="checkbox"/> <input type="checkbox"/> <input type="checkbox"/> -SFL/HLN Pneumatic Diaphragm Three-way Regulating Valve
25	PJCV- <input type="checkbox"/> <input type="checkbox"/> <input type="checkbox"/> <input type="checkbox"/> <input type="checkbox"/> -S1N Precision Small Pneumatic Diaphragm Angle Control Valve
26	PCV- <input type="checkbox"/> <input type="checkbox"/> <input type="checkbox"/> <input type="checkbox"/> <input type="checkbox"/> -LFL/HLN Pneumatic Diaphragm Three-way Regulating Valve
28	PCV- <input type="checkbox"/> <input type="checkbox"/> <input type="checkbox"/> <input type="checkbox"/> <input type="checkbox"/> -B1N Pneumatic Diaphragm Fluorine-lined Bellows Regulating Valve
29	PYCV- <input type="checkbox"/> <input type="checkbox"/> <input type="checkbox"/> <input type="checkbox"/> <input type="checkbox"/> -S1D Pneumatic Diaphragm Y-type Steam Trap
30	PVCV- <input type="checkbox"/> <input type="checkbox"/> <input type="checkbox"/> <input type="checkbox"/> <input type="checkbox"/> Pneumatic V-type Regulating Ball Valve
31	PCV- <input type="checkbox"/> <input type="checkbox"/> <input type="checkbox"/> <input type="checkbox"/> <input type="checkbox"/> -S1D Pneumatic Piston Cut-off Valve
32	PCV- <input type="checkbox"/> <input type="checkbox"/> <input type="checkbox"/> <input type="checkbox"/> <input type="checkbox"/> Pneumatic Regulating Butterfly Valve
33	PCV- <input type="checkbox"/> <input type="checkbox"/> <input type="checkbox"/> <input type="checkbox"/> <input type="checkbox"/> -S1N Pneumatic Diaphragm Shut-off Valve
35	ECV- <input type="checkbox"/> <input type="checkbox"/> <input type="checkbox"/> <input type="checkbox"/> <input type="checkbox"/> -S2DLC Electric Straight-through Single-seat Regulating Valve
36	ECV- <input type="checkbox"/> <input type="checkbox"/> <input type="checkbox"/> <input type="checkbox"/> <input type="checkbox"/> -S3DLC Electric Straight-through Double-seat Regulating Valve
37	ECV- <input type="checkbox"/> <input type="checkbox"/> <input type="checkbox"/> <input type="checkbox"/> <input type="checkbox"/> -S2381 Electronic Electric Single-seat Regulating Valve
39	ECV- <input type="checkbox"/> <input type="checkbox"/> <input type="checkbox"/> <input type="checkbox"/> <input type="checkbox"/> -S2381 Electronic Electric Sleeve Regulating Valve
41	E3CV- <input type="checkbox"/> <input type="checkbox"/> <input type="checkbox"/> <input type="checkbox"/> <input type="checkbox"/> -SFL/HL381 Electronic Electric Three-way Control Valves
43	PDV- <input type="checkbox"/> <input type="checkbox"/> <input type="checkbox"/> <input type="checkbox"/> <input type="checkbox"/> Electronic Electric Regulating Butterfly Valve
44	Self-operated Pressure Regulating Valve
46	V230/231 Self-operated Pressure Regulating Valve
47	ZZDQ Nitrogen Sealing Device
49	ZZWEP Self-operated Electric Temperature Regulating Valve
50	ZZWP Self-operated temperature regulating valve
51	Calculation of Regulating Valve Diameter
52	Appendix

I	II	III	IV
---	----	-----	----

Valve Type

-

V	VI	VII	VIII
---	----	-----	------

Valve Body

-

IX	X	XI
----	---	----

Valve Body Structure and Actuator

Number Description

Code.I	Control method
--------	----------------

P	Pneumatic control
E	Electric control

Code.II	Control method
---------	----------------

	Normal type
3	Tee-type
J	Angle type
Z	Z-type

Code.III	Control
----------	---------

C	Control
---	---------

Code.IV	Valve
---------	-------

V	Valve
---	-------

Code.V	Mounting method
--------	-----------------

1	Threaded
2	Flange
3	Wafer
4	Ferrules
5	Welding
6	Quick-install

Code.VI	Valve body material
---------	---------------------

P	304
R	316
C	Cast steel
F	2205

Code.VII	Valve core material
----------	---------------------

P	304
R	316
C	Cast steel
F	2205

Code.VIII	Seal material
-----------	---------------

F	PTFE
F4	F46
H	Hard seal

Code.IX	Valve bonnet type
---------	-------------------

S	Conventional
H	High-temperature heat sink
L	Low-temperature extended bonnet
B	Metal bellows seal bonnet

Code X	Valve seat type
--------	-----------------

1	Cage Single Seat
2	Sleeve Single Seat
3	Sleeve Double Seat
4	Multi-hole Low Noise
5	Multi-stage Pressure Reduction
6	Unbalanced Multi-stage Pressure Reduction
FL	Three-way Diverting
HL	Three-way Mixing

Code.XI	Pneumatic actuator
---------	--------------------

N	Without handwheel
C	Side-mounted handwheel
D	Top-mounted handwheel

Code.XI	Electric actuator
---------	-------------------

DLC	
381	
DL	
DSL	Ex-proof

Control Valve Body Type

Appearance and applicable working conditions of different valve bodies

The blue box is the valve body type of our company's regulating valve

1 Straight Valve Body

MODEL 1



The straight-through valve body presents an S-shaped streamlined channel with a smooth inner wall and equal cross-section. It has the characteristics of small pressure loss, large flow rate and smooth flow.

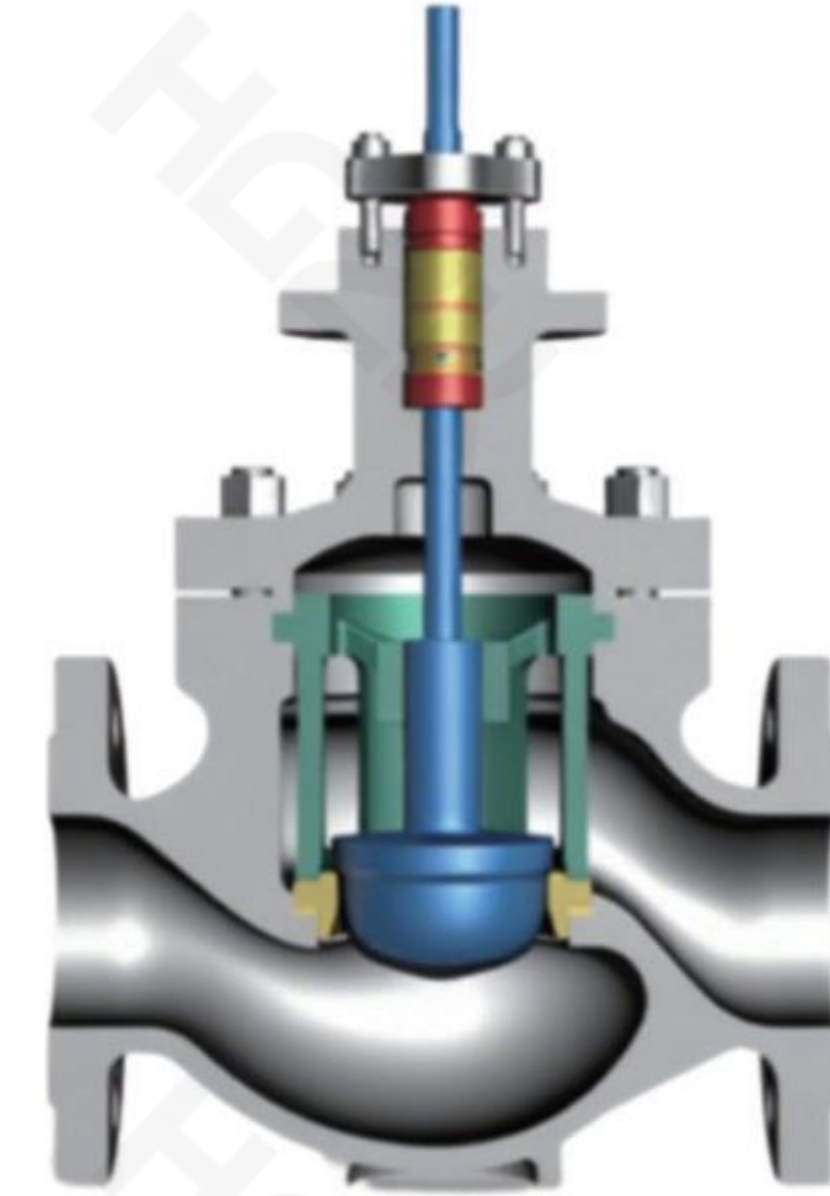

CV

2 Three-way Valve Body

MODEL 2



Three-way valve bodies are divided into two types: converging and diverting.

They are mainly used for proportional regulation or bypass regulation, occupying small space and low cost.

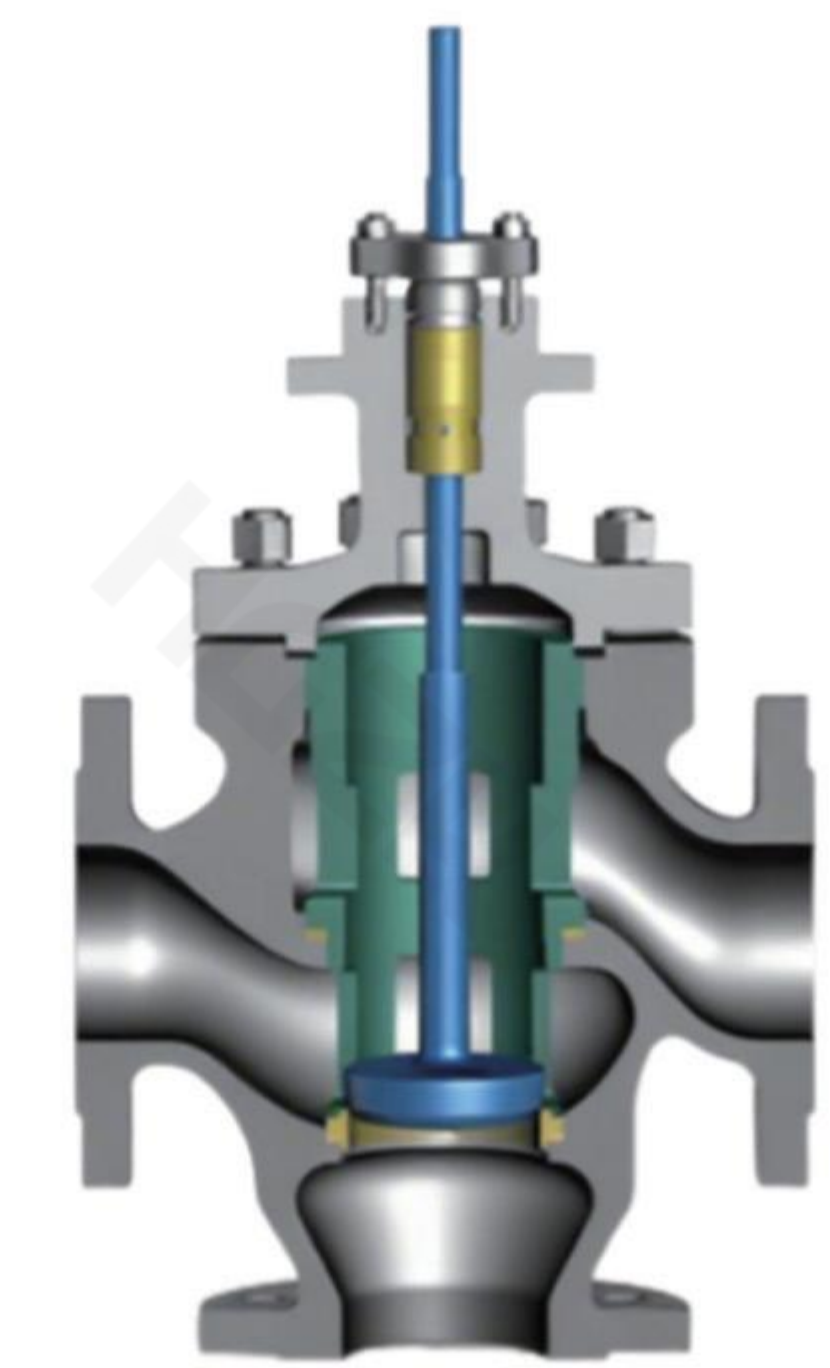

3CV

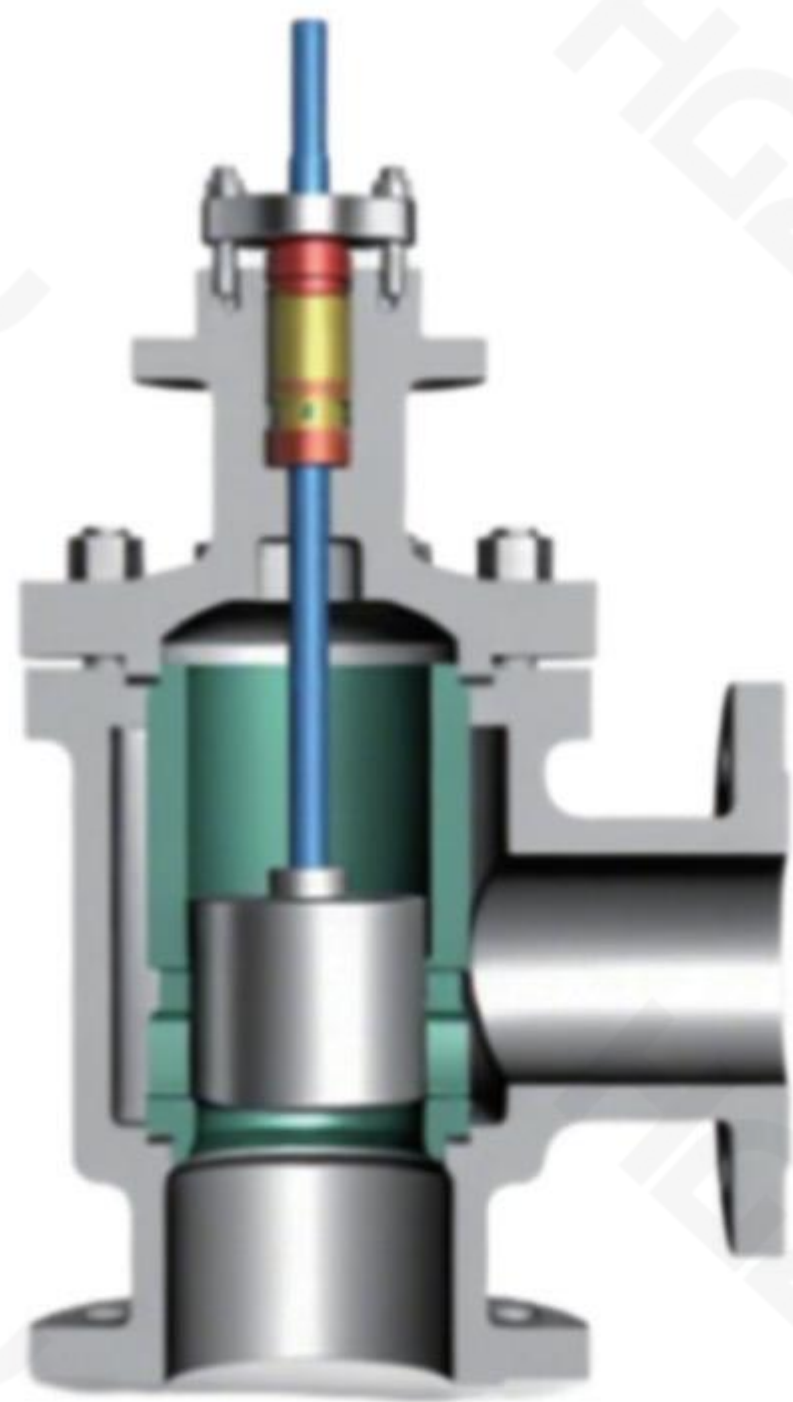

JCV

3 Angled Valve Body

MODEL 3



The angle valve body is fully compatible with the straight-through valve body, except for its right-angled shape.

It features a compact structure, simple flow path, and low resistance.

It is particularly suitable for working conditions prone to coking, clogging, and high viscosity.

4 Z-shaped Valve Body

MODEL 4



The Z-shaped valve body is primarily suitable for high-pressure applications.

Made from a single piece of forging, it offers superior compressive strength.

Its simple internal flow path is less susceptible to vortices and backflow, minimizing the possibility of flash evaporation and cavitation in high-pressure differential applications.

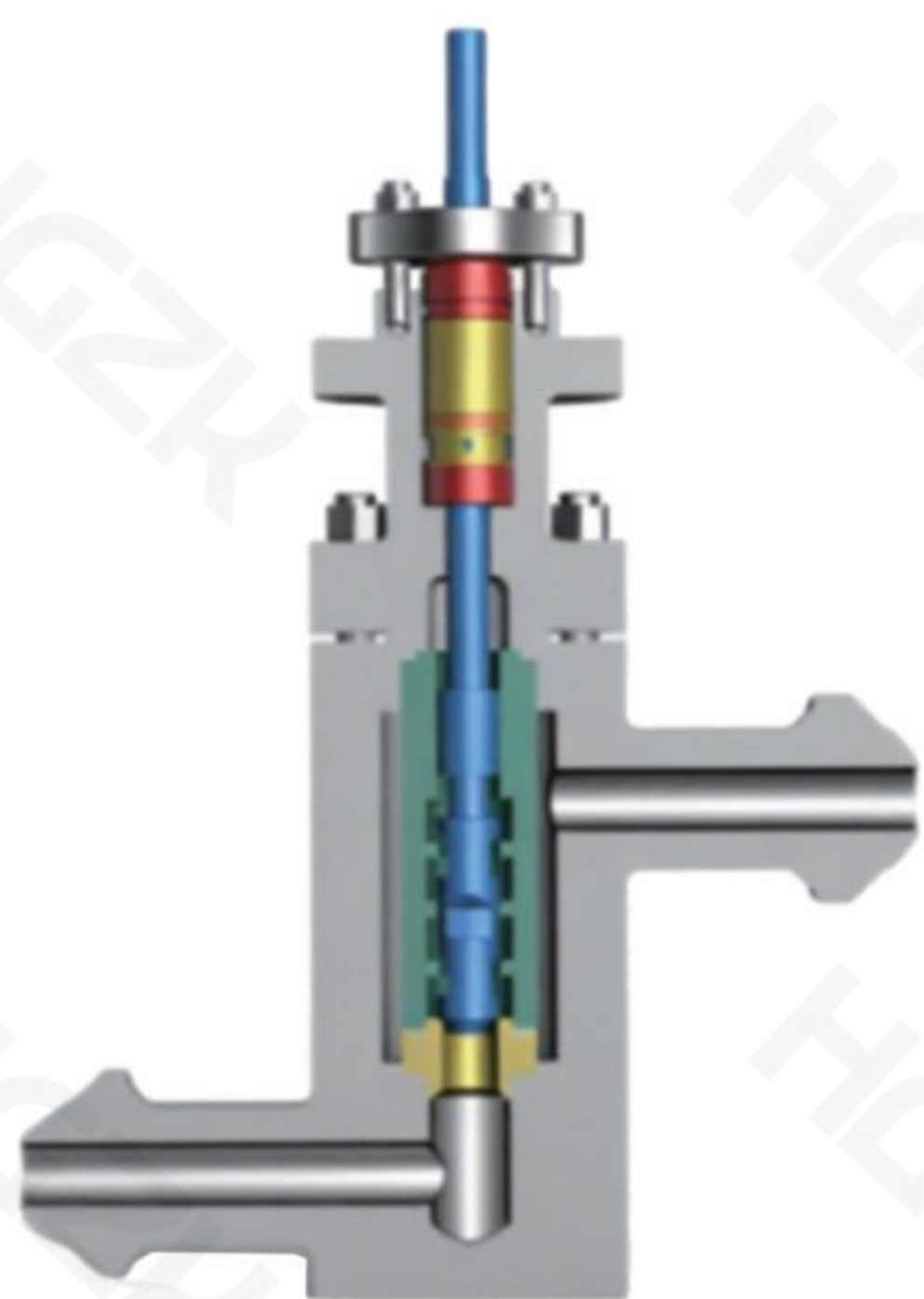

ZCV

Control Valve Bonnet Type

The appearance and characteristics of different valve covers

The blue box is the valve bonnet type of our company's regulating valve

S

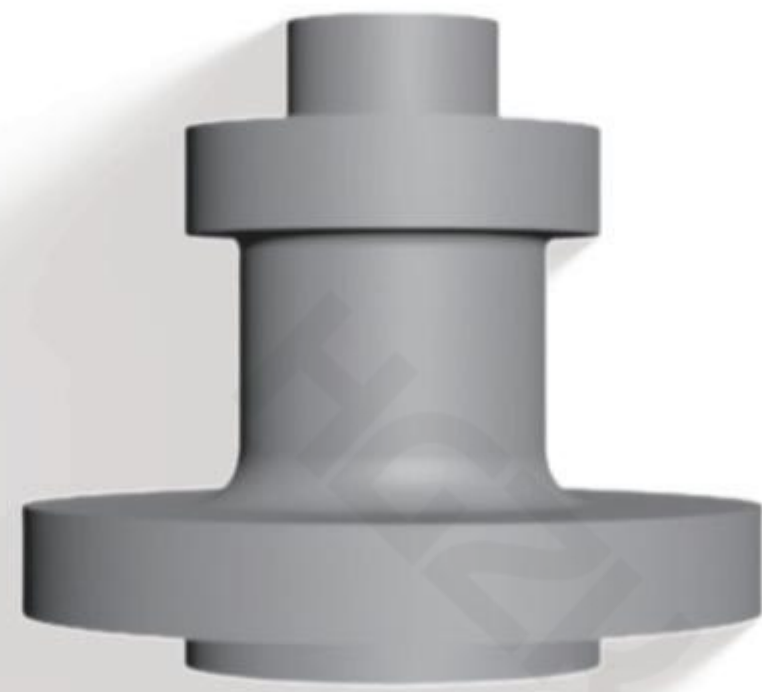

Standard Bonnet

The straight-through valve body presents an S-shaped streamlined channel with a smooth inner wall and equal cross-section.

It has the characteristics of small pressure loss, large flow rate, and smooth flow.

Operating temperature	-30°C to 260°C
-----------------------	----------------

H

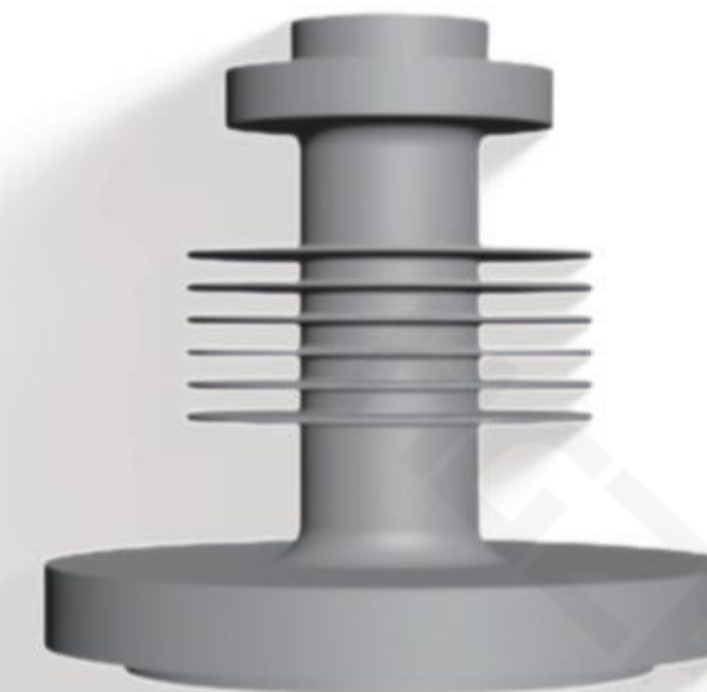

High Temperature Bonnet

The high-temperature bonnet is designed for high-temperature operating conditions. Heat sinks increase the contact area between the bonnet and the surrounding air, effectively protecting the packing and actuator.

Operating temperature	+230°C to 530°C
-----------------------	-----------------

Operating temperature2	-45°C to -5°C
------------------------	---------------

L



Low Temperature Extended Bonnet

The cryogenic mid-length bonnet is suitable for cryogenic media (such as liquid oxygen and liquid nitrogen). This type of bonnet effectively protects the filler and actuator. Standard materials are 304 or 316. Materials with different expansion coefficients can also be used depending on the operating conditions.

Operating temperature	-196°C to 45°C
-----------------------	----------------

B



Metal Bellows Seal Bonnet

The metal bellows seal bonnet is equipped with a stainless steel bellows assembly to isolate the medium from the outside. And can ensure that the valve stem moves up and down. In addition, there is still a standard stuffing box inside the upper bonnet to ensure no waste or environmental pollution due to leakage of the medium.

Operating temperature	-60°C to 530°C
-----------------------	----------------

Control Valve Body Material

Characteristics of different valve body materials

High Temperature Material

As a high-temperature material, high-temperature strength, microstructure changes at high temperatures, and corrosion resistance must be fully considered. Alloy steels are generally required to contain chromium, nickel, and aluminum. Furthermore, under high temperatures and pressures, hydrogen attack on steel typically causes decarburization and embrittlement. The addition of metallic elements such as chromium, nickel, and molybdenum to steel, which combine with carbon, can improve the steel's resistance to hydrogen corrosion.

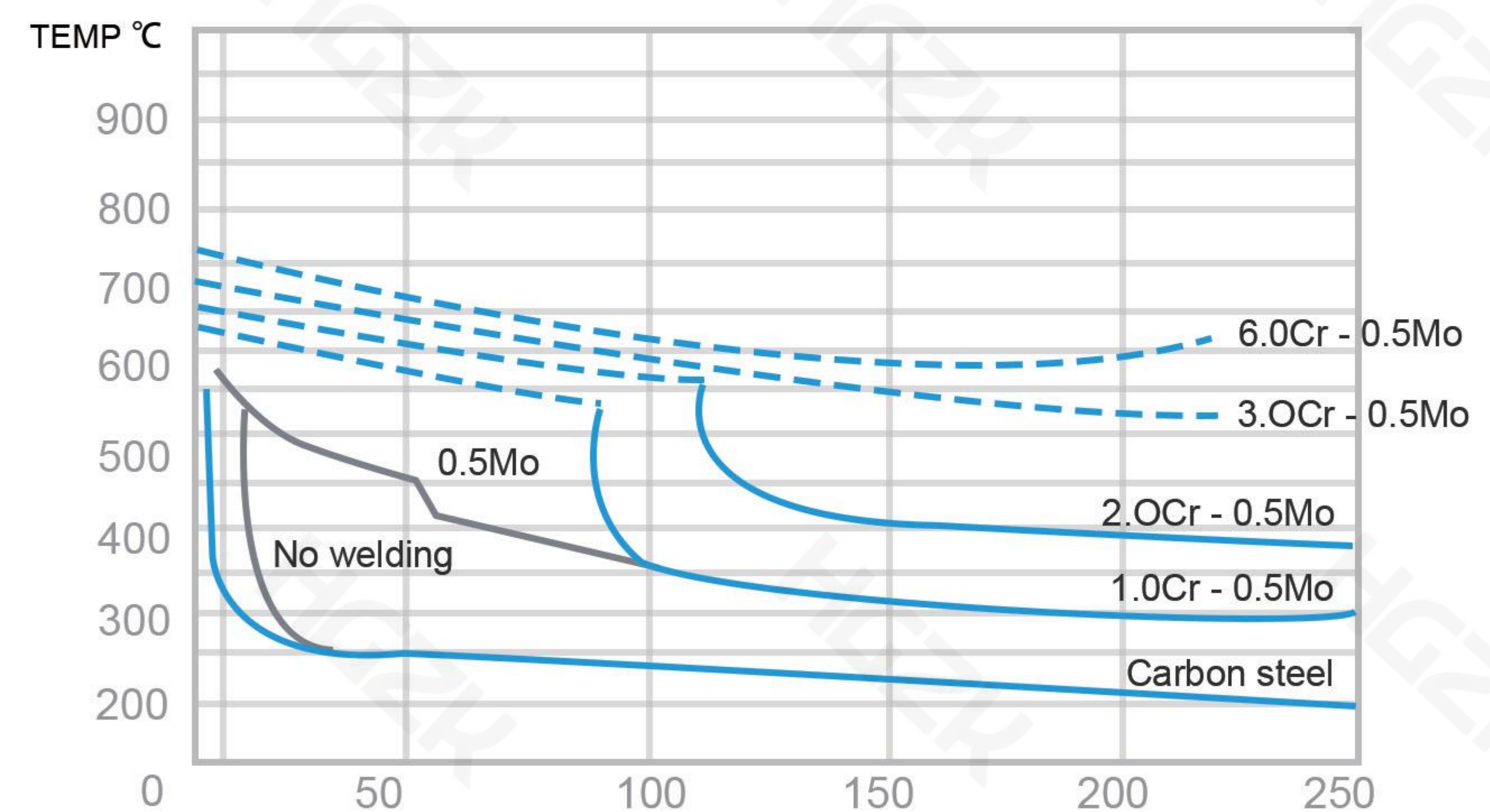

Application range of carbon steel and alloy steel under high temperature and high pressure hydrogen

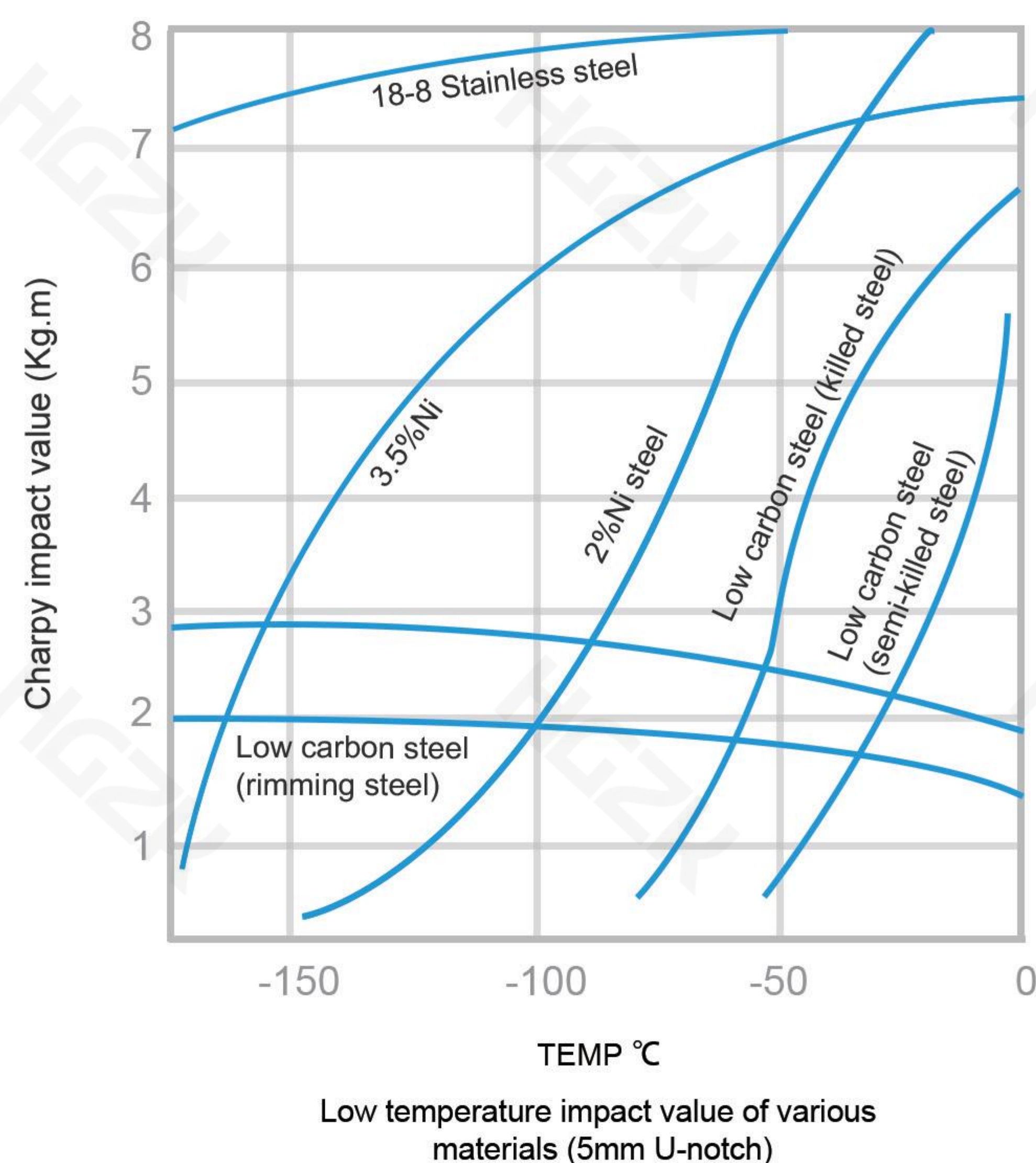

Low temperature impact value of various materials (5mm U-notch)

Cryogenic Materials

When selecting low-temperature materials, it's important to fully consider the material's low-temperature impact resistance and the brittleness associated with reduced toughness at low temperatures. Therefore, materials used in low-temperature conditions must exhibit sufficient toughness at these temperatures. To be safe and reliable, the steel used in valves at different temperatures must meet the specified impact energy requirements at the appropriate temperature. Austenitic stainless steel is often used due to its relatively stable low-temperature mechanical properties.

Cavitation-resistant Materials

When the fluid is liquid, especially when flashing and cavitation occur, the material's cavitation resistance must be fully considered. Cavitation-resistant materials are primarily categorized into two types:

- High-hardness materials (hardness is increased through heat treatment);
- Materials with a strong oxide layer, high toughness, and high fatigue strength (surface heat treatment increases surface hardness);
- Locally hardened materials (welding treatment).

Metal materials

The degree of corrosion of metal materials is generally categorized as general corrosion, interstitial corrosion, inter-product corrosion, pitting corrosion, and stress corrosion. No single material is resistant to all of these types of corrosion. In reality, the material's corrosiveness is also dependent on the type, concentration, and temperature of the fluid, as well as factors such as the presence of oxidants and flow rate, further complicating material selection. Commonly used corrosion-resistant materials for control valves include lining materials such as PTFE and F46, or more expensive specialty metals such as various austenitic stainless steels, 20# alloy steel, Hastelloy B, Hastelloy C, and titanium.

Control Valve Stuffing Box Structure

Seals on regulating valve stems

MODEL 1

Standard Packing

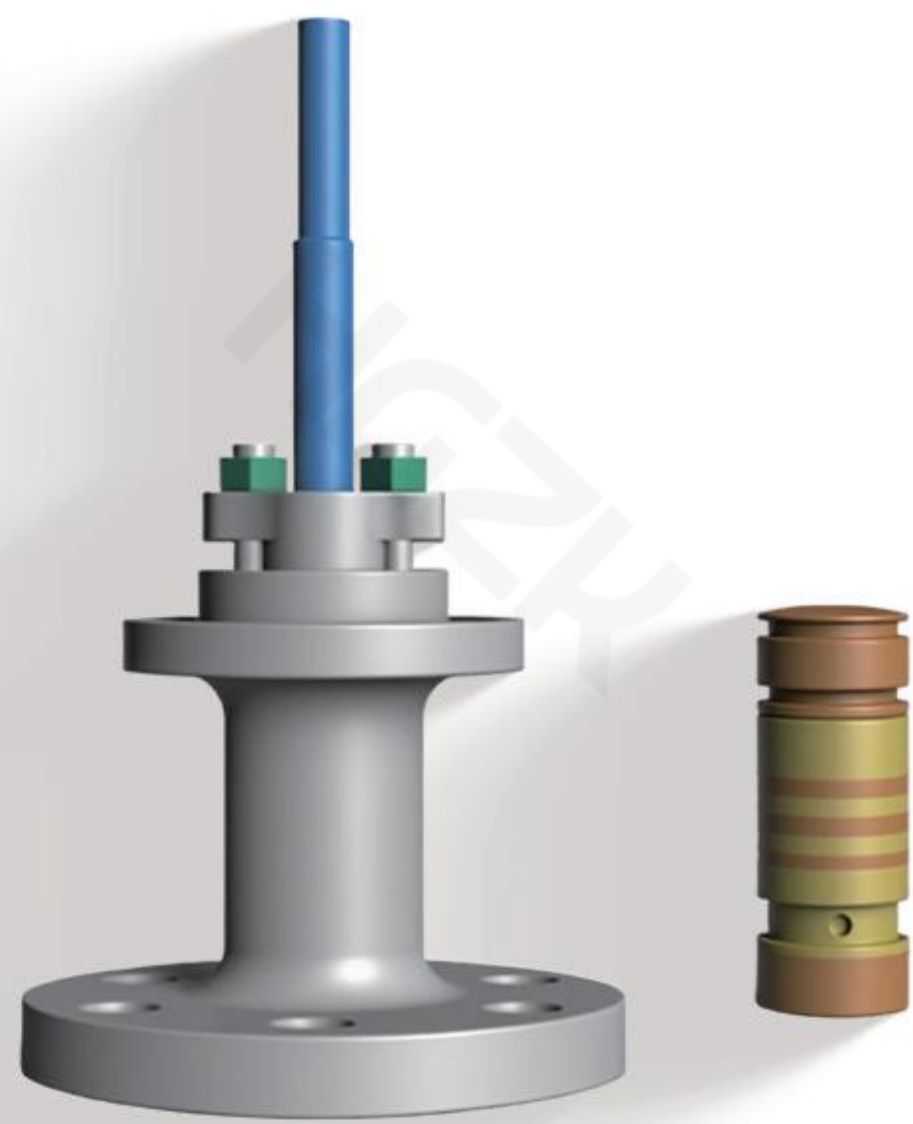

Standard Stuffing Box Structure

Integrated stuffing box features standard packing configuration. Modular design allows for easy replacement and maintenance. The packing consists of multiple U-shaped sealing rings with a compensating seal.

Operating temperature -30°C to 260°C

MODEL 2

High Temperature Filler

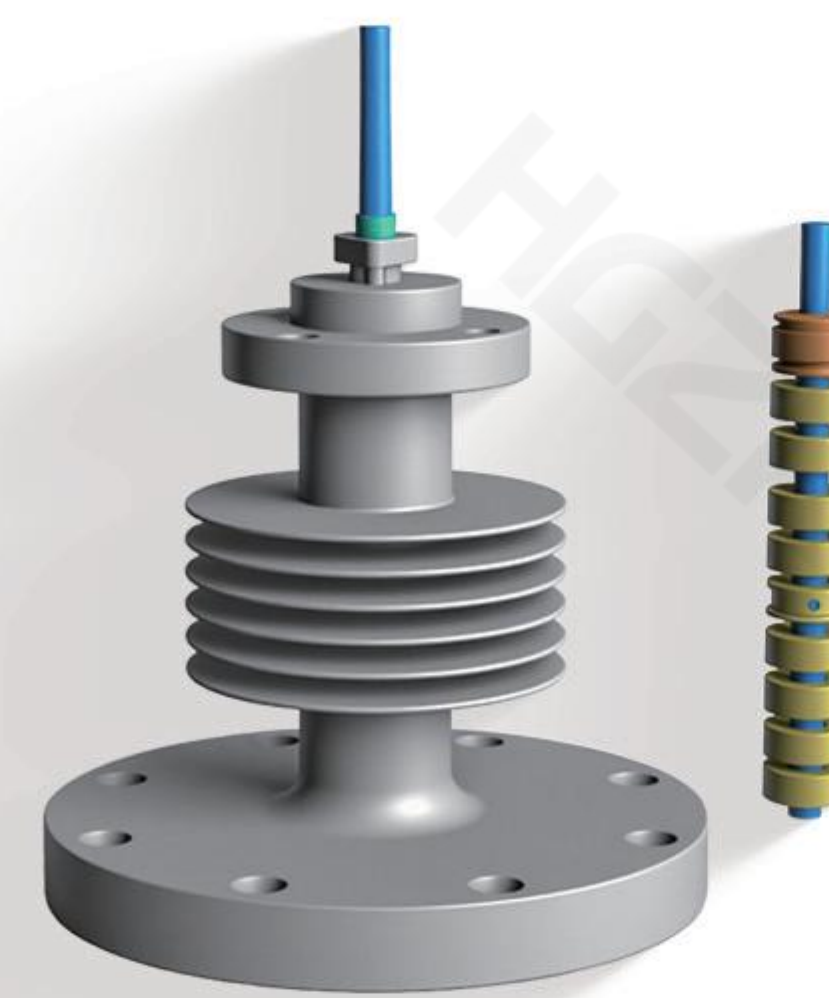

High Temperature Stuffing Box Structure

V-shaped flexible graphite is used as the high-temperature filler. This filler consists of V-shaped graphite with varying tapers. Operating temperature: -45°C to 530°C.

Operating temperature -45°C to 530°C.

Sealing Material Pressure/ Temperature Range

The packing acts as a seal at the valve stem, ensuring the valve stem's up-and-down movement.

Type Material Temperature Range	Material	Temperature Range
Standard type	PPL\PTFE	-30°C~260°C -30°C~230°C
High temperature type	V-type flexible graphite RTFE	-30°C~540°C -50°C~250°C
Bellows seal	304/316 Hastelloy C-276/Monel	-196°C~400°C -250°C~530°C

MODEL 3

Bellows Packing



Bellows Stuffing Structure

Bellows valve stem seals typically utilize a bellows and a standard stuffing box for dual sealing, providing a reliable seal against highly toxic or cryogenic media. The metal bellows isolate the media from the outside world while ensuring the vertical movement of the valve stem.

Operating temperature -60°C to 530°C

Control Valve Connection Method

Different connection methods of control valves

Flange Connection

The end connection forms of the regulating valves produced by our company mainly include flange connection and butt welding connection.

Small-diameter ones can also be designed into socket welding connection and threaded connection.

They can also be designed according to customer requirements.

Note: When using valves with $PN \geq 4.0\text{MPa}$, the integral flange on the valve is generally concave, while the sealing surface of the pipe flange should be convex.

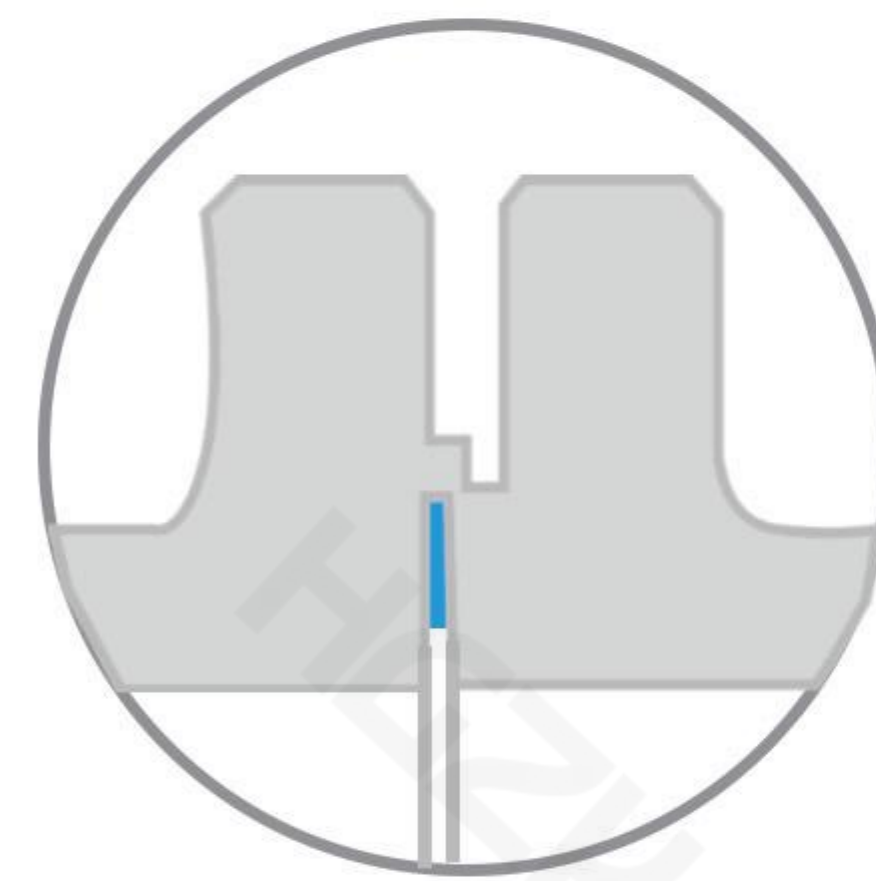

MFM concave-convex surface

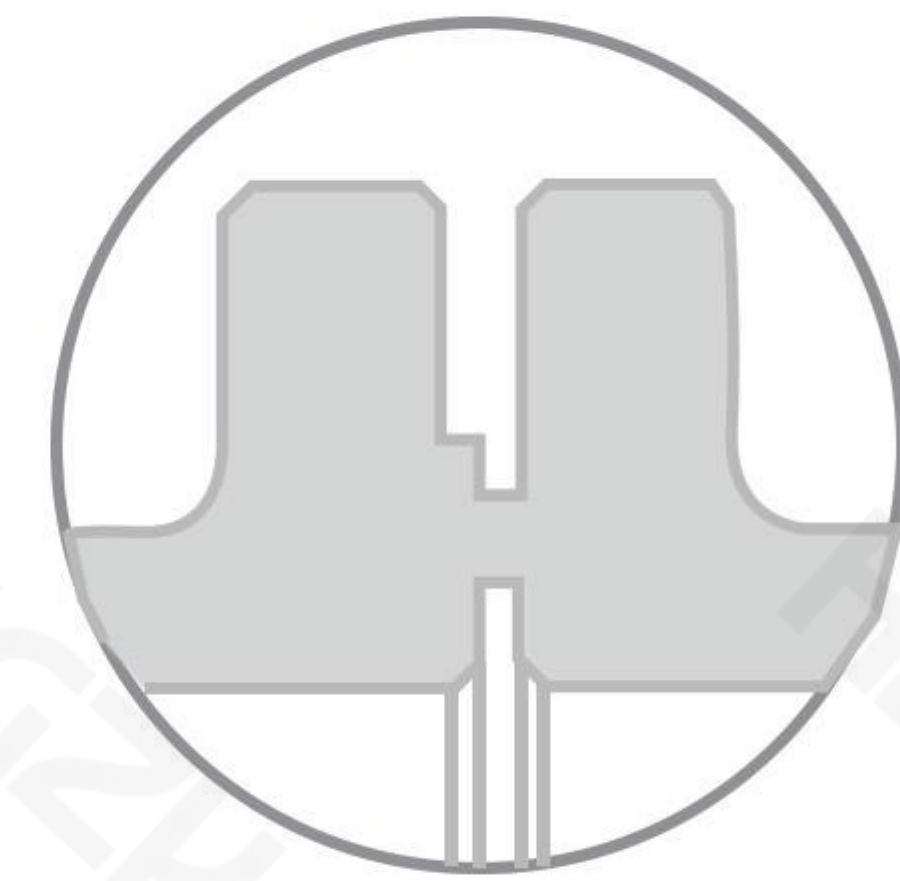

TG tongue and groove surface

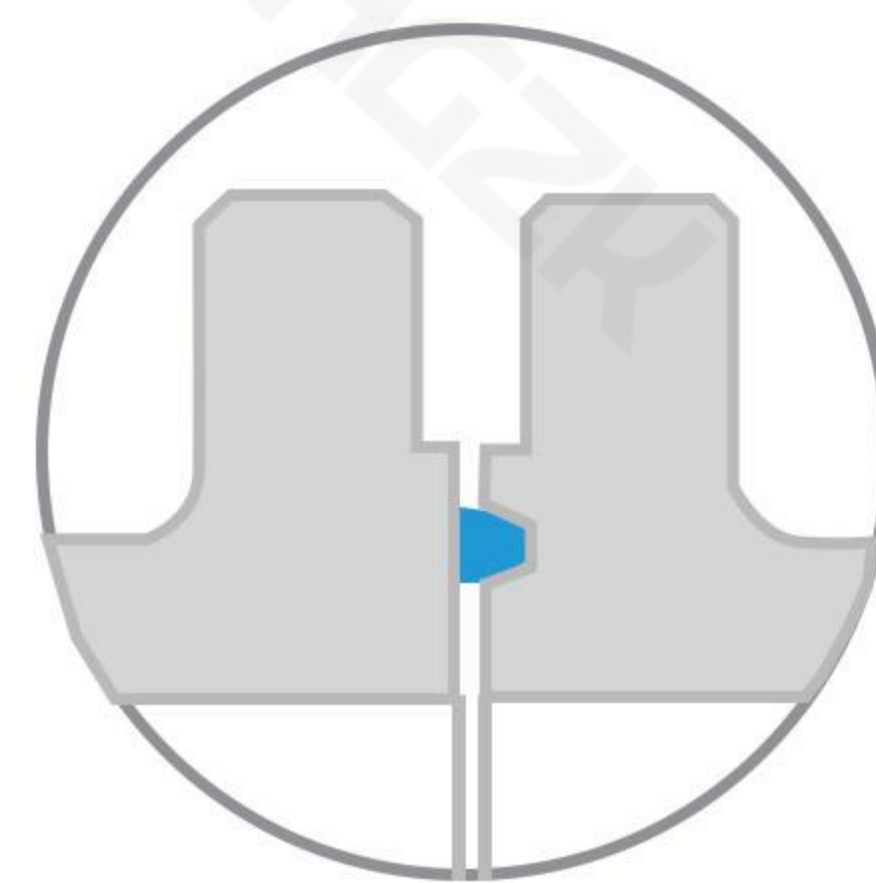

RJ ring connection surface

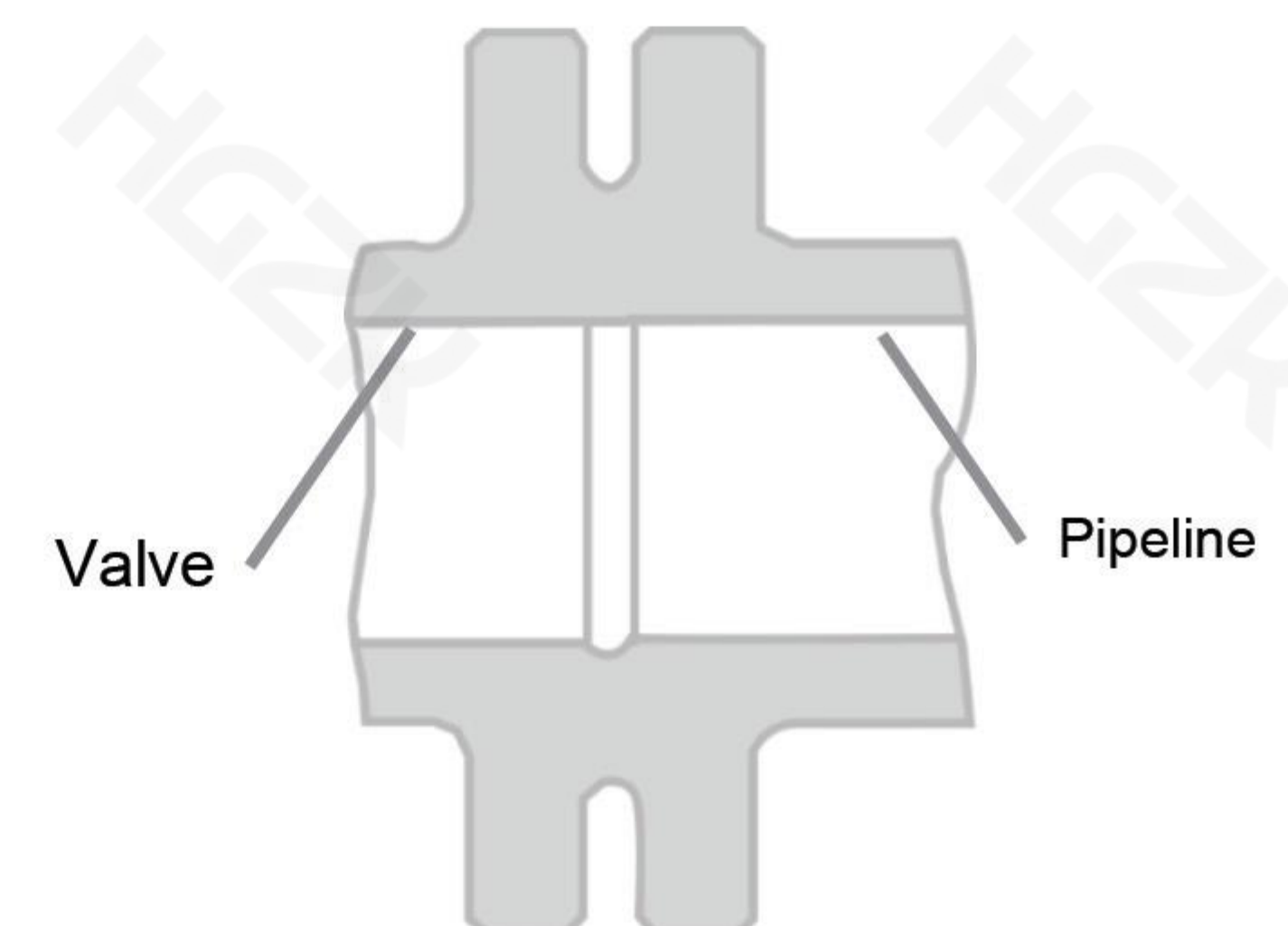

RF raised surface

Butt Welding End

Unless otherwise specified by the customer, the butt-welding ends of the control valves we produce are processed in accordance with the groove dimensions specified in GB/T12224 and ASME B16.25.

Socket Soldering Terminal

Unless otherwise specified by the customer, the socket welding ends of the control valves we produce are processed in accordance with the dimensions specified in JB/T1751 and ASME B16.11.

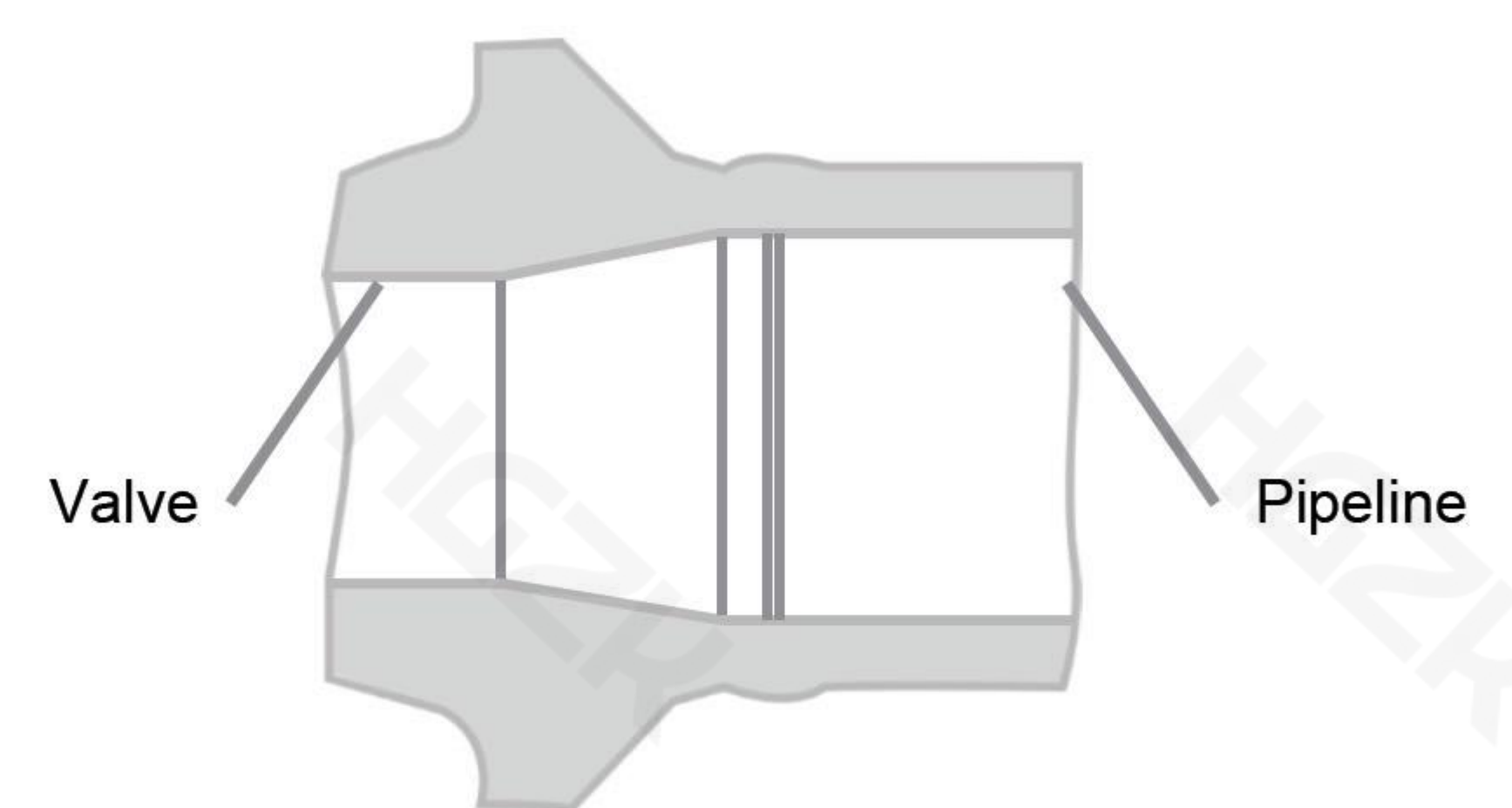
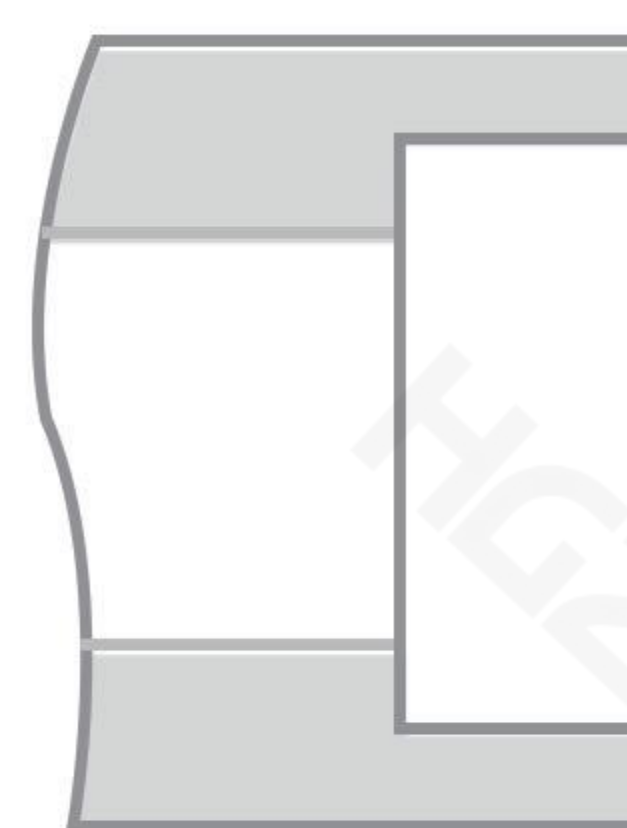

Sealing ring type	Sealing from	Leakage rating	Temperature range
Balanced sealing ring	Pressure self-sealing	ANSI/FCI 70-2-2013 ClassV	-30°C~260°C
Metal C-ring	Extrusion seal/ Pressure self-sealing	ANSI/FCI 70-2-2013 ClassV	-196°C~650°C
Composite graphite seal	Extrusion seal	ANSI/FCI 70-2-2013 ClassV	-196°C~560°C

Control Valve Selection

Overview of different control valve structures

The blue box is the valve seat code of our company's regulating valve

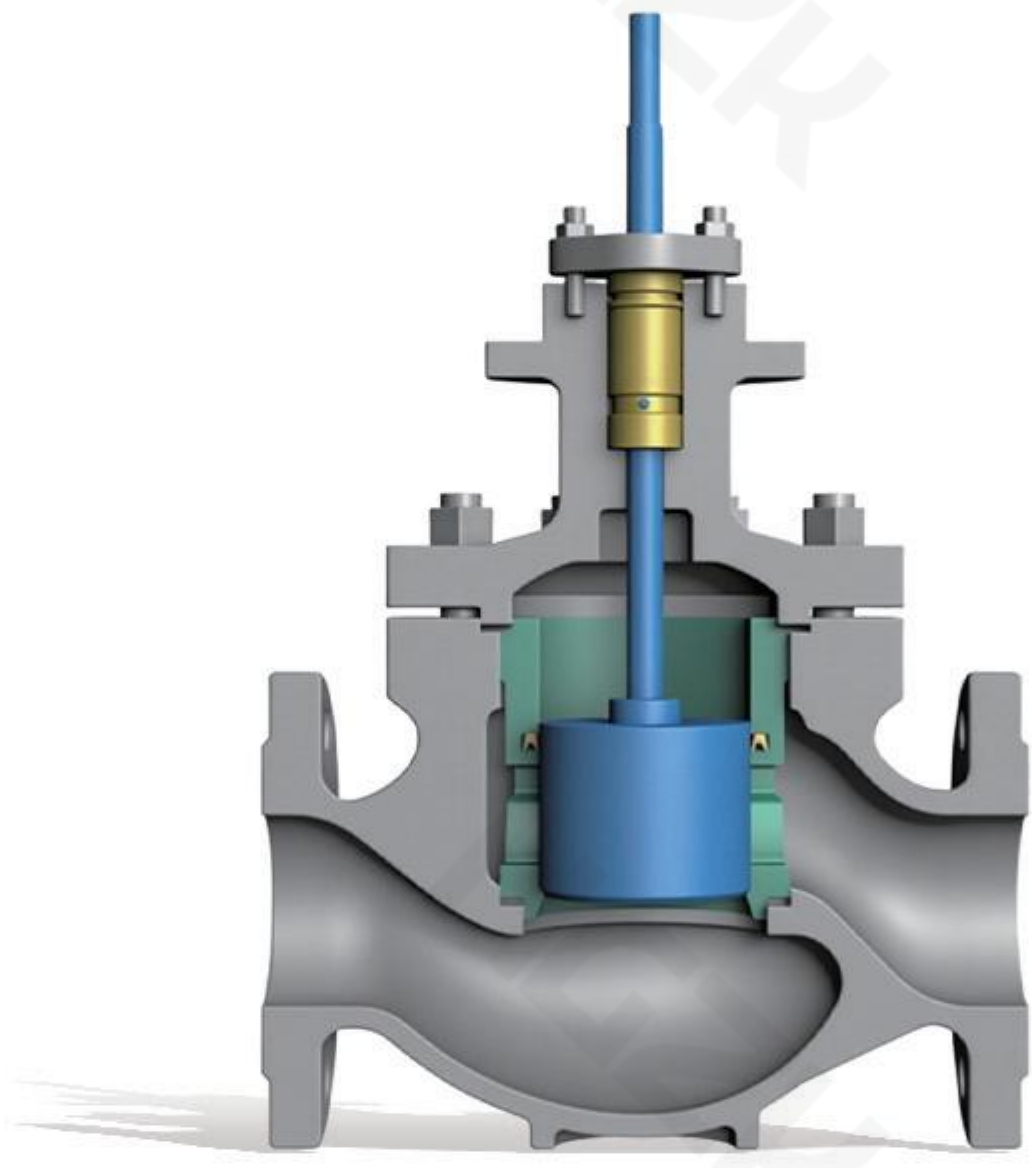

1 Cage Type Single Seat Regulating Valve

Valve Trim Features	Top-guided unbalanced trim Quick-release cage structure
Valve Body Type	Straight-through, Angle
Bonnet styles	Standard, Heat Dissipation Low-Temperature, Bellows
Flow Characteristics	Equal Percentage, Linear, Quick Opening
Leakage Rating	ANSI/FCI70-2-2013V (Standard Metal Seat) ANSI/FCI70-2-2013VI (Shut-off Soft Seat)
Pipe Connections	Flange, Butt-weld
Applicable Temp Range	-196°C to 570°C
Actuator Type	Pneumatic Diaphragm Actuator Pneumatic Piston Actuator Electric Actuator

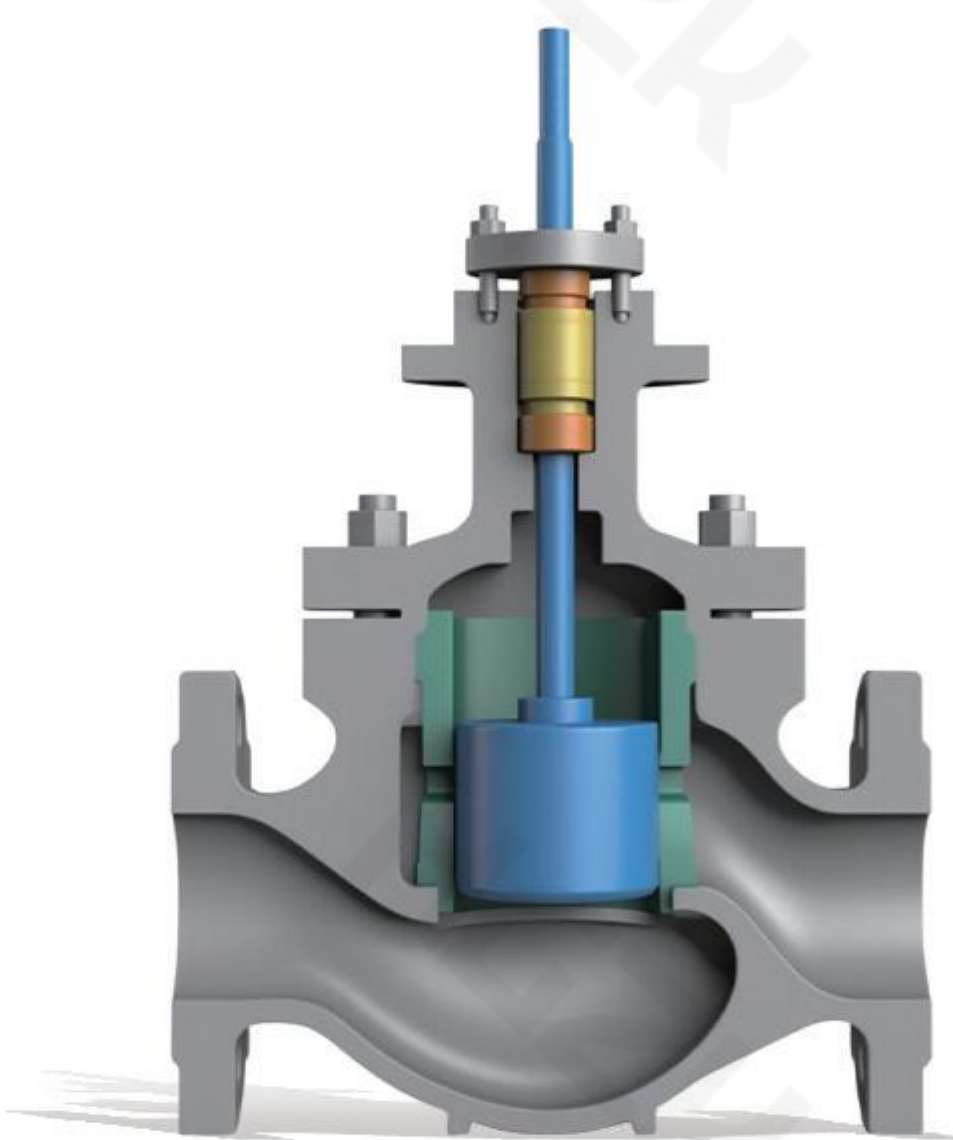

2 Sleeve Single-seat Regulating Valve

Valve Trim Features	Sleeve-guided, balanced trim With balanced seal ring
Valve Body Type	Straight-through, Angle
Bonnet styles	Standard, Heat Dissipation Low-Temperature, Bellows
Flow Characteristics	Equal Percentage, Linear, Quick Opening
Leakage Rating	ANSI/FCI70-2-2013 V (Standard Metal Seat) ANSI/FCI70-2-2013 VI (Shut-off Soft Seat)
Pipe Connections	Flange, Butt-weld
Applicable Temp Range	-30°C to 260°C
Actuator Type	Pneumatic Diaphragm Actuator Pneumatic Piston Actuator Electric Actuator

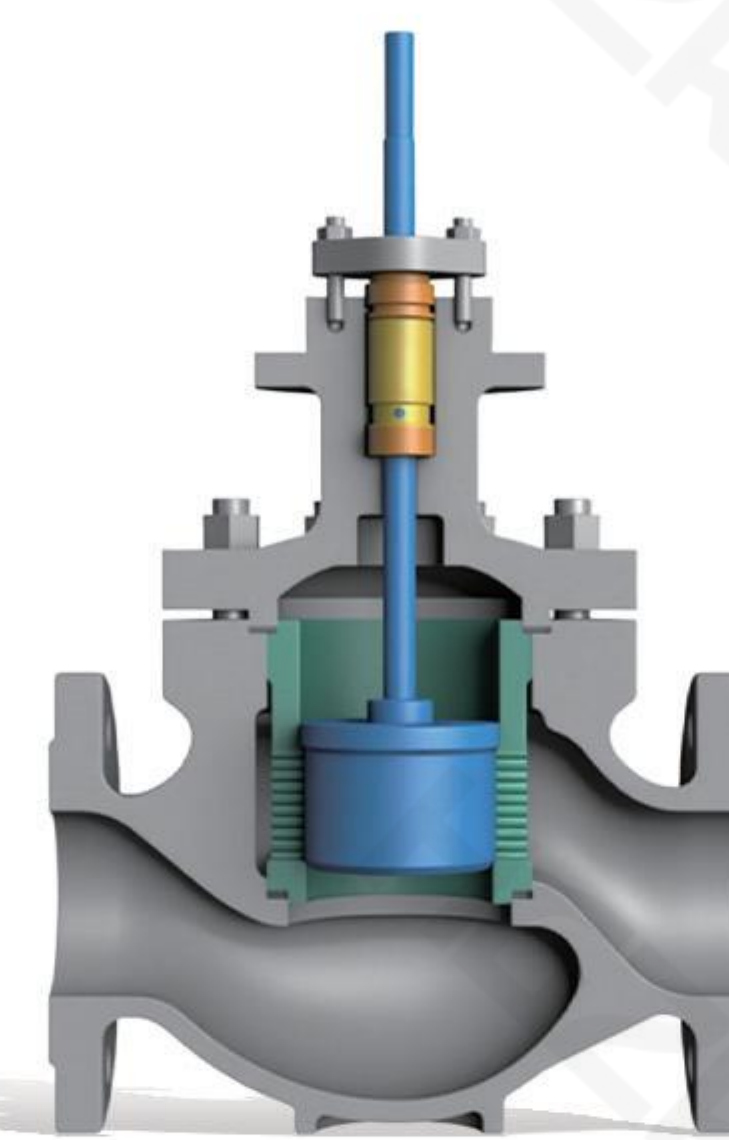

3 Sleeve Double-seat Regulating Valve

Valve Trim Features	Sleeve-guided, balanced trim structure
Valve Body Type	Straight-through, Angle
Bonnet styles	Standard, Heat Dissipation Low-Temperature, Bellows
Flow Characteristics	Equal Percentage, Linear, Quick Opening
Leakage Rating	ANSI/FCI70-2-2013 V (Standard Metal Seat) ANSI/FCI70-2-2013 VI (Shut-off Soft Seat)
Pipe Connections	Flange, Butt-weld
Applicable Temp Range	-196°C to 570°C
Actuator Type	Pneumatic Diaphragm Actuator Pneumatic Piston Actuator Electric Actuator

4 Multi-hole Low Noise Regulating Valve

Valve Trim Features	Sleeve-guided, balanced trim With balanced seal ring
Valve Body Type	Straight-through, Angle
Bonnet styles	Standard, Heat Dissipation Low-Temperature, Bellows
Flow Characteristics	Equal Percentage, Linear, Quick Opening
Leakage Rating	ANSI/FCI70-2-2013 V (Standard Metal Seat) ANSI/FCI70-2-2013 VI (Shut-off Soft Seat)
Pipe Connections	Flange, Butt-weld
Applicable Temp Range	-30°C-260°C (Single-seat) -196°C-570°C (Double-seat)
Actuator Type	Pneumatic Diaphragm Actuator Pneumatic Piston Actuator Electric Actuator

Control Valve Selection

Overview of different control valve structures

The blue box is the valve seat code of our company's regulating valve

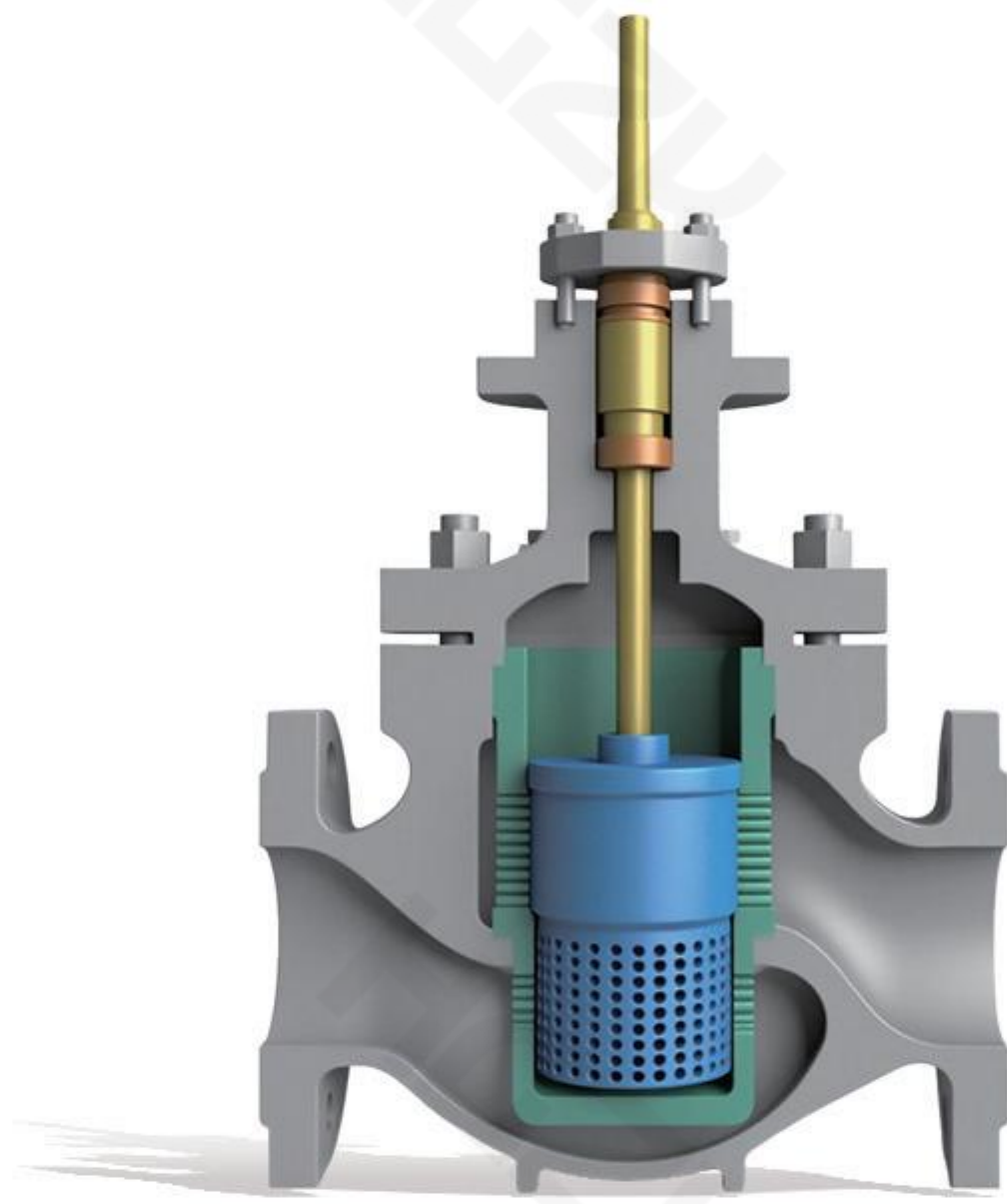

5 Multi-stage Pressure Reducing Regulating Valve

Valve Trim Features	Sleeve-guided, balanced trim With balanced seal ring
Valve Body Type	Straight-through , Angle
Bonnet styles	Standard, Heat Dissipation Low-Temperature, Bellows
Flow Characteristics	Equal Percentage, Linear, Quick Opening
Leakage Rating	ANSI/FCI70-2-2013 V (Standard Metal Seat) ANSI/FCI70-2-2013 VI (Shut-off Soft Seat)
Pipe Connections	Flange, Butt-weld
Applicable Temp Range	-30°C-260°C (Single-seat) -196°C-570°C (Double-seat)
Actuator Type	Pneumatic Diaphragm Actuator Pneumatic Piston Actuator Electric Actuator

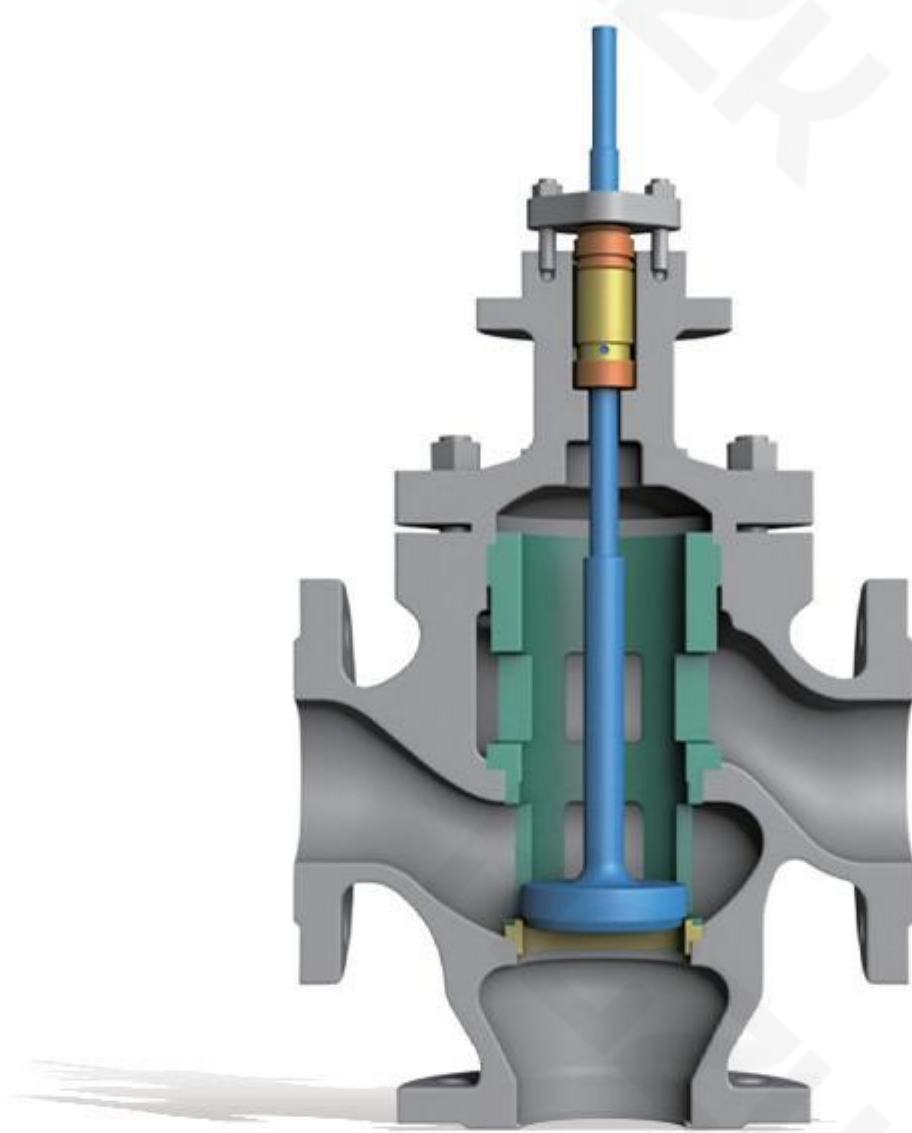

FL Three-way Divergence Regulating Valve

Valve Trim Features	Dual Seat Sleeves with Simple Guide
Valve Body Type	Three-Way
Bonnet styles	Standard, Heat Dissipation Low-Temperature, Bellows
Flow Characteristics	Equal Percentage, Linear, Quick Opening
Leakage Rating	ANSI/FCI70-2-2013 VI (Standard Metal Seat)
Pipe Connections	Flange, Butt-weld
Applicable Temp Range	-196°C to 560°C
Actuator Type	Pneumatic Diaphragm Actuator Pneumatic Piston Actuator Electric Actuator

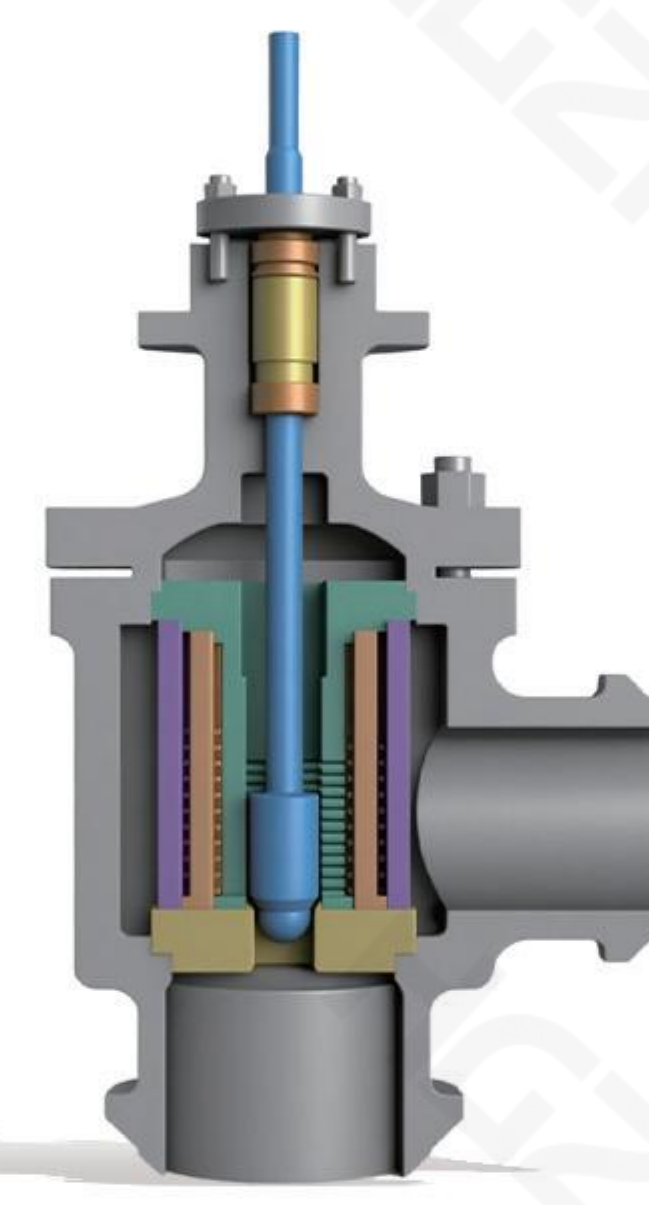

6 Unbalanced Multi-stage Pressure Reducing Regulating Valve

Valve Trim Features	Top-guided unbalanced trim Quick-release cage structure
Valve Body Type	Straight-through, Angle
Bonnet styles	Standard, Heat Dissipation Low-Temperature, Bellows
Flow Characteristics	Equal Percentage, Linear, Quick Opening
Leakage Rating	ANSI/FCI70-2-2013 V (Standard Metal Seat) ANSI/FCI70-2-2013 VI (Shut-off Soft Seat)
Pipe Connections	Flange, Butt-weld
Applicable Temp Range	-196°C to 570°C
Actuator Type	Pneumatic Diaphragm Actuator Pneumatic Piston Actuator Electric Actuator

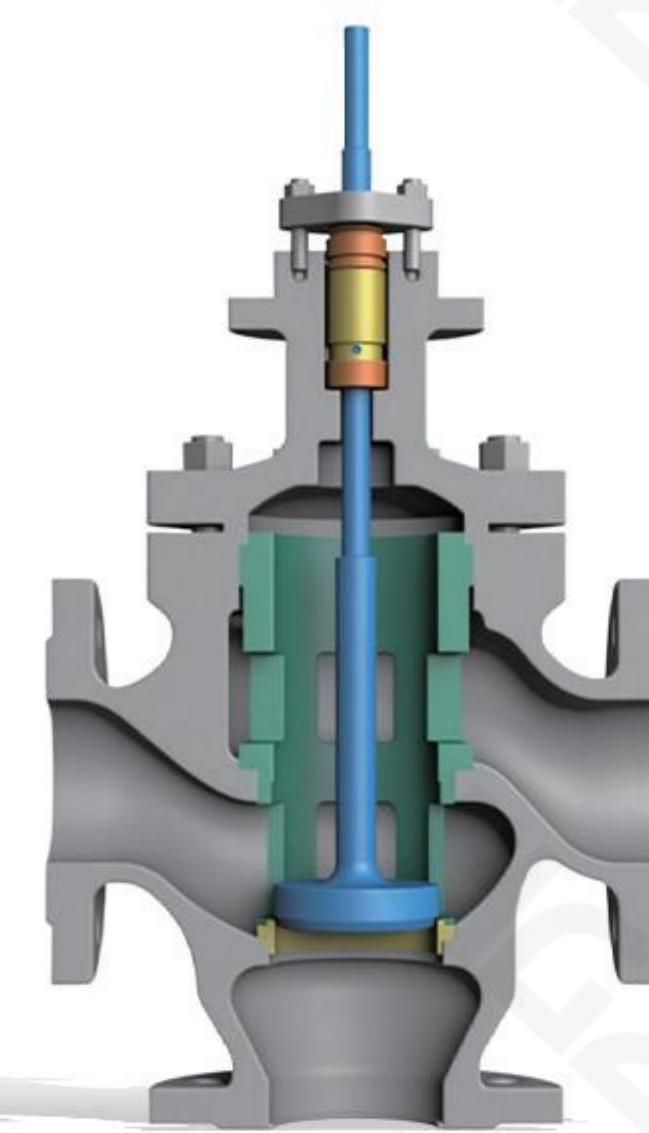

HL Three-way Confluence Regulating Valve

Valve Trim Features	Dual Seat Sleeves with Simple Guide
Valve Body Type	Three-Way
Bonnet styles	Standard, Heat Dissipation Low-Temperature, Bellows
Flow Characteristics	Equal Percentage, Linear, Quick Opening
Leakage Rating	ANSI/FCI70-2-2013 VI (Standard Metal Seat)
Pipe Connections	Flange, Butt-weld
Applicable Temp Range	-196°C to 560°C
Actuator Type	Pneumatic Diaphragm Actuator Pneumatic Piston Actuator Electric Actuator



N Without handwheel
pneumatic diaphragm
actuator



C Side mounted handwheel
pneumatic diaphragm
actuator



D Top mounted handwheel
pneumatic diaphragm
actuator

Pneumatic Actuator Selection

Electric Actuator Selection



IF IF Series
Electric Actuator



381 381L type
Electric Actuator



DLC T-type
Electric Actuator



DL Ordinary explosion-proof
Electric Actuator



DSL Flameproof
Electric Actuator

Choose what you need

International Brand Positioner

Choose what suits you



FISHER



Samson



Flowserve



Azbil



YTC



Tissin



Siemens



ABB

Choose what you need

Domestic Brand Positioner

Choose what suits you



HEP



YT1000



L8A



MVP

* Not limited to the above brands and product series, please contact us for more customized services

PCV-VVIVIIVIII-S1N Precision Small Pneumatic Single Seat Regulating Valve

Overview

- The PCV-VVIVIIVIII-S1N pneumatic single-seat control valve consists of a pneumatic multi-spring diaphragm actuator and a low-resistance single-seat valve.
- The new actuator features a low profile, lightweight, and easy installation and calibration.
- The new valve body is compact, offers unobstructed flow paths, and boasts a high flow coefficient.
- This product offers stable operation, reliable actuation, minimal seat leakage, precise flow characteristics, and a wide adjustable range.
- Its unique advantages are sure to achieve high-quality control results in a wide range of applications.



Main technical parameters and performance indicators

Main technical parameters of the regulating mechanism

Nominal diameter (mm)		20		25	40	50	65	80	100	150	200				
Valve seat diameter (mm)		10	12	15	20	25	32	40	50	65	80	100	125	150	200
Rated flow coefficient Kv	Straight line	1.8	2.8	4.4	6.9	11	17.6	27.5	44	69	110	176	275	440	690
	Equal percentage	1.6	2.5	4	6.3	10	16	25	40	63	100	160	250	400	630
Nominal pressure (MPa)		0.6		1.6	4.0	6.4									
Journey (mm)		10		16	25	40	60								
Traffic characteristics		Straight line, equal percentage													
Medium temperature (°C)		-15~200 (Normal temperature type), -40~+250, -40~450 (Medium temperature type)													
Flange size		Cast iron flange dimensions are in accordance with JB78 Cast steel flange dimensions are in accordance with JB79													
Flange type		The flange sealing surface type is according to JB77, In which the cast iron flange is smooth and the cast steel flange is concave.													
Body material	PN (MPa)	0.6\1.6		HT200											
		4.0\6.4		WCB(ZG230-450)、ZG1Cr18Ni9Ti、ZG0Cr18Ni12Mo2Ti											
Valve core material		1Cr18Ni9、0Cr18Ni12Mo2Ti													
Upper bonnet form		Ordinary type (normal temperature type), thermal sheet type (medium temperature type)													
Adjustable ratio R		50:1													
Air source connector		M16 × 1.5													

Note: We can provide users with ANSI/JPI/JIS flange products, and the structural length can also be determined according to user needs.

Main technical parameters of actuator mechanism

Model	ZHA(B)-22	ZHA(B)-23	ZHA(B)-34	ZHA(B)-45
Effective area (cm ²)	350	350	560	900
Stroke (mm)	16	25	40	60
Spring range (KPa)	20-100(Standard); 40-200; 80-240; 20-60; 60-100			

Performance Indicators

Project		Index value
Basic error%	Without locator	±5.0
	With locator	±1.0
Hysteresis %	Without locator	≤3.0
	With locator	≤1.0
Dead difference %	Without locator	≤3.0
	With locator	≤0.4
Rated stroke deviation%		±2.5

Project		Index value	
Deviation of starting and ending points%	Air-to-close type	Without locator	start ±5.0
		Without locator	End ±2.5
	With locator	start	±1.0
		End	±1.0
Air-to-open type	Without locator	start	±2.5
		End	±5.0
	With locator	start	±1.0
		End	±1.0
Allowable leakage L/h			1×10 ⁻⁴ ×Valve rated capacity

Allowable pressure difference

MPa

Switching mode	Model	Spring range KPa	Air source pressure KPa	Attachment	Nominal diameter mm								
					25	40	50	65	80	100	150	200	
Air-to-close type	ZHA-22	20~100 20~100 40~200	0.14 0.25 0.40	- P P or R	3.00								
	ZHA-23				6.40								
	ZHA-34				6.40	2.25	1.95						
	ZHA-45				6.40	6.40	6.40	2.36	2.04	1.67			
								6.40	6.40	6.40	1.41	1.41	
								6.40	6.40	6.40	6.40	6.40	
Air-to-open type	ZHB-22	20~100 40~200 80~240	0.14 0.25 0.40	- P or R P	1.50								
	ZHB-23				4.50								
	ZHB-34				6.40	1.13	0.98						
	ZHB-45				6.40	3.38	2.93						
								6.40	6.40	6.40	1.18	1.02	0.84
								6.40	6.40	6.40	3.54	3.06	2.51
								6.40	6.40	6.40	6.40	6.40	5.85
										0.71	0.57		
										2.12	1.71		
										4.94	4.00		

Note: 1) P = valve positioner; R = pressure relay.

2) The allowable differential pressure is the maximum value of ΔP when the valve is closed and P2 = 0.

3) If the maximum differential pressure exceeds 1.0 MPa, the valve plug and seat surfaces must be welded with carbide or replaced with other materials.

PCV-VVIVIIVIII-S1N Precision Small Pneumatic Single Seat Regulating Valve

External Dimensions

DN	L			H		H1			Weight(kg)		ΦA
	ANSI150 PN16 JIS10K	ANSI300 PN40 JIS30K	ANSI600 PN64 PN10.0 JIS40K	Nor- mal	High- Temp	ANSI150 PN16 JIS10K	ANSI300 PN40 JIS30K	ANSI600 PN64 PN10.0 JIS40K	PN16	PN40 PN64	
20	184	194	206	398	548	52		65	19	23	285
25	184	197	210	410	560	57		70	20	24	
40	222	235	251	455	620	75		85	26	35	
50	254	267	286	457	627	82		90	30	40	
65	276	292	311	610	790	92		100	47	66	360
80	296	317	337	622	807	100		107	55	78	
100	352	368	394	640	850	110	117	125	65	99	
150	451	473	508	870	1130	142	150	172	130	160	470
200	600	615	650	890	1150	170	187	207	175	250	
250	650	670	690	1203	1523	202	225	235	350	470	580
300	740	770	800	1234	1554	230	257	265	500	660	

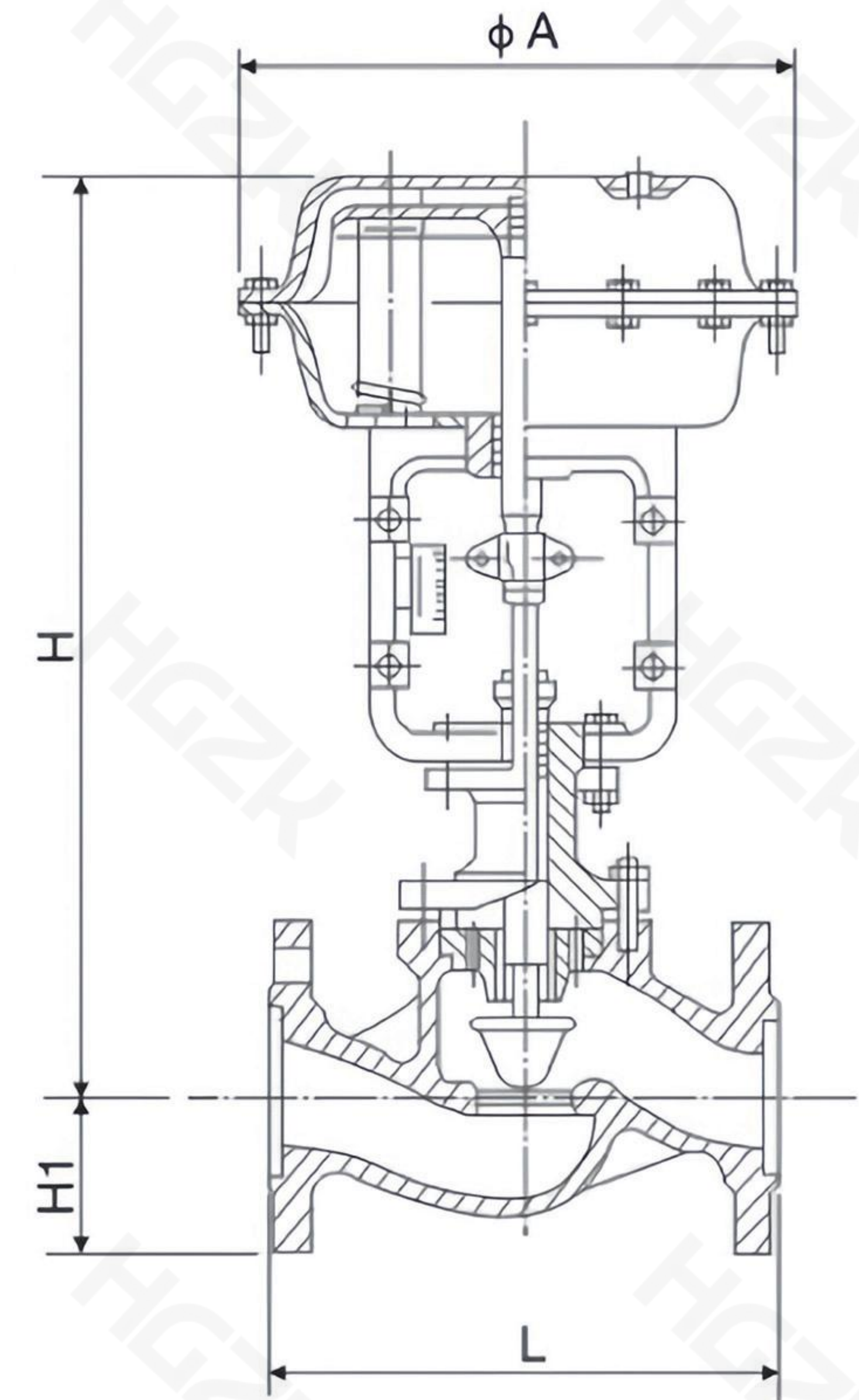

Optional Accessories

Positioner, handwheel mechanism, air filter pressure reducer, position retaining valve, etc.

Main Parts Materials

Part Name	Material	Temperature Range	Remarks
Valve body	HT200	-15~200°C	
	WCB	-20~425°C	
Upper bonnet	ZG1Cr18Ni9Ti	-40~550°C	
	ZG0Cr18Ni12Mo2Ti	-40~550°C	
Valve core, valve seat	1Cr18Ni9	-40~550°C	
	0Cr18Ni12Mo2Ti	-40~550°C	
Packing material	PTFE/Flexible graphite		
Diaphragm	Nitrile rubber reinforced polyester fabric		
Compression spring	60Si2Mn		
Diaphragm cap	A3		

Ordering Instructions

When ordering, please fill out the "Specifications" or indicate the following:

1. Product Model
2. Nominal Pressure
3. Nominal Diameter, Rated Flow Coefficient (Kv)
4. Signal Pressure, Spring Range
5. Flow Characteristics
6. Valve Opening/Closing Mode
7. Medium Operating Temperature Range
8. Valve Body and Valve Core Material
9. Accessories Included, and Part Numbers
10. Any Other Special Requirements

PCV-VVIVIIVIII-S2D Precision Small Pneumatic Sleeve Control Valve

Overview

The PCV-VVIVIIVIII-S2D pneumatic sleeve control valve features a compact design, lightweight construction, high performance, and large capacity. It is a new generation of general-purpose control valves that complies with IEC standards. It is widely used in automatic control systems for general fluid media and process conditions in industries such as petrochemicals and textiles, where installation space is compact.

This product consists of a new pneumatic multi-spring diaphragm actuator and a low-resistance sleeve valve. Features include:

1. A balanced valve core reduces unbalanced forces, allows for a large differential pressure, and ensures stable operation.
2. A large valve core guide surface mitigates vibration caused by vortices and shock, reducing damage.
3. Noise reduction of approximately 10dB compared to conventional single- and double-seat control valves.
4. A simple structure allows for easy assembly and maintenance.



Main technical parameters of the regulating mechanism

Nominal diameter (mm)		25	40	50	65	80	100	150	200		
Valve seat diameter (mm)		25	32	40	50	65	80	125	150	200	
Rated flow coefficient Kv	Straight line	11	17.6	27.6	44	69	110	176	275	440	690
	Equal percentage	10	16	25	40	63	100	160	250	400	630
Nominal pressure (MPa)		0.6 1.6 4.0 6.4									
Journey (mm)		16	25	40			60				
Traffic characteristics		Straight line, equal percentage									
Medium temperature (°C)		-15~200、-40~+250(Normal temperature type)					-40~450 (Medium temperature type)				
Flange size		Cast iron flange dimensions are in accordance with JB78 Cast steel flange dimensions are in accordance with JB79									
Flange type		The flange sealing surface type is according to JB77, In which the cast iron flange is smooth and the cast steel flange is concave.									
Body material	PN (MPa)	0.6/1.6	HT200								
		4.0/6.0	WCB(ZG230-450)、ZG1Cr18Ni9Ti、ZG0Cr18Ni12Mo2Ti								
Valve core material		1Cr18Ni9、0Cr18Ni12Mo2Ti									
Upper bonnet form		Ordinary type (normal temperature type), Thermal sheet type (medium temperature type)									
Adjustable ratio R		50:1									

Note: We can provide users with ANSI/JPI/JIS flange products, and the structural length can also be determined according to user needs.

Main technical parameters of actuator mechanism

Model	ZHA(B)-22	ZHA(B)-23	ZHA(B)-34	ZHA(B)-45
Effective area (cm ²)	350	350	560	900
Journey (mm)	16	25	40	60
Spring range (KPa)	20-100(Standard); 40-200; 80-240; 20-60; 60-100			

Performance Indicators

Project		Index value
Basic error%	Without locator	±5.0
	With locator	±1.0
Hysteresis %	Without locator	≤3.0
	With locator	≤1.0
Dead difference %	Without locator	≤3.0
	With locator	≤0.4
Rated stroke deviation%		±2.5

Project			Index value	
Deviation of starting and ending points%	Air-to-close type	Without locator	Start	±5.0
			End	±2.5
	With locator	Start	±1.0	
		End	±1.0	
Air-to-open type	Without locator	Start	±2.5	
		End	±5.0	
	With locator	Start	±1.0	
		End	±1.0	
Allowable leakage L/h				2×10 ⁻³ ×Valve rated capacity

Allowable pressure difference

MPa

Switching mode	Model	Spring range KPa	Air source pressure KPa	Attachment	Nominal diameter mm							
					25	40	50	65	80	100	150	200
Air-to-close type	ZHA-22	20~100 20~100 40~200	0.14 0.25 0.40	- P P or R	3.00 6.40 6.40							
	ZHA-23				2.25 6.40 6.40	1.95 6.40 6.40						
	ZHA-34						2.36 6.40 6.40	2.04 6.40 6.40	1.67 6.40 6.40			
	ZHA-45									1.41 6.40 6.40	1.41 6.40 6.40	
Air-to-open type	ZHB-22	20~100 40~200 80~240	0.14 0.25 0.40	- P or R P	1.50 4.50 6.40							
	ZHB-23				1.13 3.38 6.40	0.98 2.93 6.40						
	ZHB-34						1.18 3.54 6.40	1.02 3.06 6.40	0.84 2.51 5.85			
	ZHB-45									0.71 2.12 4.94	0.57 1.71 4.00	

Note: 1) P = valve positioner; R = pressure relay.

2) The allowable differential pressure is the maximum value of ΔP when the valve is closed and P2 = 0.

3) If the maximum differential pressure exceeds 1.0 MPa, the valve plug and seat surfaces must be welded with carbide or replaced with other materials.

PCV-VVIVIIVIII -S2D Precision Small Pneumatic Sleeve Control Valve

External Dimensions

DN	L			H		H1			Weight(kg)		ΦA
	ANSI150 PN16 JIS10K	ANSI300 PN40 JIS30K	ANSI600 PN64 PN10.0 JIS40K	Normal	High-Temp	ANSI150 PN16 JIS10K	ANSI300 PN40 JIS30K	ANSI600 PN64 PN10.0 JIS40K	PN16	PN40 PN64	
25	184	197	210	410	560	57		70	20	24	285
40	222	235	251	455	620	75		85	26	35	
50	254	267	286	475	627	82		90	30	40	
65	276	292	311	610	790	92		102	47	66	360
80	298	317	337	622	807	100		107	55	78	
100	352	368	394	640	850	110	117	125	65	99	
150	451	473	508	870	1130	142	150	175	130	160	470
200	600	615	650	890	1150	170	187	207	175	250	
250	650	670	690	1203	1523	202	225	235	350	470	580
300	740	770	800	1234	1554	230	257	265	500	660	

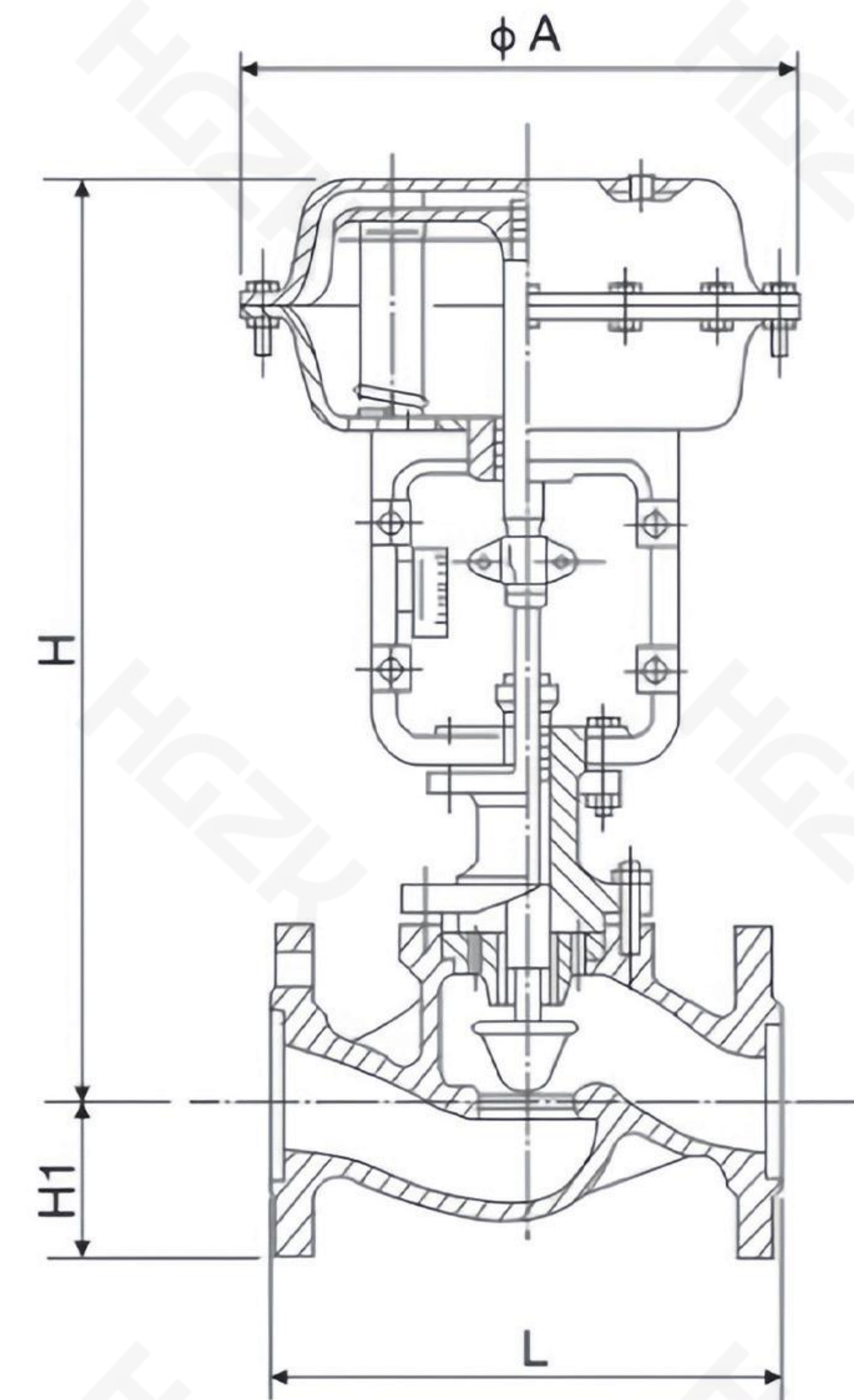

Optional Accessories

Positioner, handwheel mechanism, air filter pressure reducer, position retaining valve, etc.

Main Parts Materials

Part Name	Material	Temperature Range	Remarks
Valve body	HT200	-15~200°C	
	WCB	-20~425°C	
Upper bonnet	ZG1Cr18Ni9Ti	-40~550°C	
	ZG0Cr18Ni12Mo2Ti	-40~550°C	
Valve core, valve seat	1Cr18Ni9	-40~550°C	
	0Cr18Ni12Mo2Ti	-40~550°C	
Packing material	PTFE/Flexible graphite		
Diaphragm	Nitrile rubber reinforced polyester fabric		
Compression spring	60Si2Mn		
Diaphragm cap	A3		

Ordering Instructions

When ordering, please fill out the "Specifications" or indicate the following:

1. Product Model
2. Nominal Pressure
3. Nominal Diameter, Rated Flow Coefficient (Kv)
4. Signal Pressure, Spring Range
5. Flow Characteristics
6. Valve Opening/Closing Mode
7. Medium Operating Temperature Range
8. Valve Body and Valve Core Material
9. Accessories Included, and Part Numbers
10. Any Other Special Requirements

PCV-VVIVIIVIII-S2N Single Seat Control Valve

Overview

- The PCV-VVIVIIVIII-S1N single-seat control valve features a top-guided structure.
- The valve body's fluid passageway is streamlined in an S-shape, minimizing pressure drop, providing high flow rates, a wide adjustable range, a highly accurate flow characteristic curve, a large valve core guide area, and excellent vibration resistance.
- The control valve is equipped with a multi-spring diaphragm actuator, offering a compact design and high output force.
- It can be used to control fluids of various pressures and temperatures.

Technical parameters and performance

VALVE BODY

Model	Straight-through single-seat casting ball valve
Nominal Diameter (mm)	ANSI125、150、300、600 JS10、16、20、30、40K PN1.6、4.0、6.4MPa
Nominal Pressure	40-200mm
Connection Type	Flange Types: FF, RF, RJ, LG Standards: ANSI B16.5; JIS B2201 JB/T79.1 PN 1.6MPa, JB/T79.2 Concave and convex weld types: Scarf weld (SW) (40-50mm) Butt weld (BW) (65-200mm)
Material	HT200 ZG25 ZG1Cr18Ni9 ZG0Cr17Ni12Mo2 1.25Cr0.5Mo 5.0Cr0.5Mo SCPH21 SCPH61 TI
Upper valve cover	Normal Temperature Type (P):-17~230°C Elongated Type I (E1): 230~566°C -45~17°C Elongated Type II (E2): Integrated Type (E2 I): -100~-45°C Welded Type (E2 W): -196~-100°C
Gland type	Bolt-on type
Filler	V-type PTFE packing, PTFE-impregnated asbestos packing, and asbestos braided packing.

Valve internal components

Valve core type	Top-guided, single-seat, Gui plug valve core
Flow characteristics	High-precision flow characteristics High-capacity flow characteristics Quick-opening characteristics: Quick-opening valve core
Working Range	Soft valve seat operating temperature and gland Stellite overlay operating temperature and gland
Material	1Cr18Ni9Ti Stellite overlay



ACTUATOR

Model	HA Multi-spring diaphragm pneumatic actuator
Diaphragm material	Ethylene Propylene Rubber Clip
Spring range	0.02~0.10、0.08~0.24MPa
Gas supply pressure	0.14、0.16、0.28MPa
Air source connector	Rc 1/4
Ambient temperature	-30~70°C
Remark	This valve can also be equipped with VA5 or VA6 and VP actuator
Valve action form	Air-to-open、Air-to-close
Accessories	Positioners, retaining valves, handwheel pneumatic valve position transmitters, etc.

Performance

Leakage	Metal seat: Meets ANSI B16.104 Class IV. Less than 0.01% of rated Cv. PTFE seat: Meets ANSI B16.104 Class N. Less than 10 ⁻⁷ rated Cv. Stellite welded seat: Less than 10 ⁻⁷ rated Cv (quick-opening valve plug).
Hysteresis	3% (without positioner); 1% (with positioner).
Linear	±5% (without positioner); ±1% (with positioner).
Adjustable range	50:1

PCV-VVIVIIVIII -S2N Single Seat Control Valve

CV value and stroke

Nominal diameter (mm)		40			50			65			80			100			150			200		
Valve seat diameter (mm)		25	32	40	32	40	50	40	50	65	50	65	80	65	80	100	100	125	150	125	150	200
Rated Cv value	High-precision valve core	10	17	24	17	24	44	24	44	68	44	68	99	68	99	175	175	275	360	275	360	640
	High capacity spool			30			50			85			125			200			420			700
	Quick opening valve core			35			55			95			135			220			460			720
Rated stroke (mm)	Other valve cores	25						38						50			75					
	Quick opening valve core	10			13			19			25			30			50					

NOTE:High-precision metal valve seat flow characteristics comply with IEC534-2

Allowable pressure difference

Actuator	Gas supply pressure (MPa)	Spring range (MPa)	Positioner	Allowable pressure difference(MPa)												
				DN 25	DN 32	DN 40	DN 50	DN 65	DN 80	DN 100	DN 125	DN 150	DN 200			
HA2D	0.14	0.02-0.10	Have or No	0.63	0.38	0.27	0.16	0.10	0.07	0.05						
	0.16	0.02-0.10	Have	3.16	1.93	1.37	0.78	0.51	0.35	0.20						
	0.40	0.08-0.24	Have	4 9.4	4 4.7	4 4.1	2.17	1.49	1.05	0.59						
HA3D	0.14	0.02-0.10	Have or No	1.12	0.68	0.48	0.28	0.17	0.12	0.07	0.04	0.03				
	0.16	0.02-0.10	Have	4 5.6	3.42	2.42	1.4	0.88	0.62	0.35	0.22	0.14				
	0.40	0.08-0.24	Have	4 10	4 10	4 7.2	4 7.2	2.65	1.87	1.05	0.67	0.41				
HA4D	0.14	0.02-0.10	Have or No			0.83	0.48	0.3	0.22	0.12	0.07	0.05	0.03			
	0.16	0.02-0.10	Have			4	2.42	1.52	1.07	0.61	0.39	0.24	0.15			
	0.40	0.08-0.24	Have			4 10	4 7.2	4 4.5	3.22	1.82	1.16	0.71	0.45			
VA5D	0.14	0.02-0.10	Have or No					0.42	0.29	0.16	0.11	0.06	0.04			
	0.16		Have					2.08	1.47	0.83	0.53	0.32	0.21			

Flange distance

DN	ANSI 125FF PN1.6 ANSI 150RF JIS 10K FF RF	JIS 16K RF	ANSI 300 RF JIS 20 30K RF JIS 30 K RF	ANSI 600 RF JIS 40K RF PN6.4	JIS 16K Grooved / Embedded type	JIS 20K Grooved / Embedded type	JIS 30K Grooved / Embedded type	JIS 40K Grooved / Embedded type
40	222	231	235	251	235	236	248	251
50	254	263	267	286	265	267	276	286
65	276	288	292	311	290	292	303	311
80	298	313	317	337	310	317	326	337
100	352	364	368	394	360	368	379	394
150	451	465	473	508	475	473	486	508
200	543	560	568	610	570	568	580	610

PCV-VVIVIIVIII-S1N Caged Single Seat Control Valve

Overview

- The PCV-VVIVIIVIII-S1N caged single-seat control valve is a pressure-balanced control valve with an S-shaped streamlined flow passage in the valve body and a guide vane to improve the smooth flow of fluid around the sleeve.
- Its advantages include low pressure drop, high flow rate, a wide adjustable range, highly accurate flow characteristic curves, excellent dynamic stability, low noise, and minimal cavitation corrosion.
- The control valve is equipped with a multi-spring diaphragm actuator, offering a compact structure and high output force.
- It is suitable for controlling high- and low-temperature, high-pressure differential fluids.

Technical parameters and performance

VALVE BODY

Model	Straight-through double-seat casting ball valve
Nominal Diameter (mm)	ANSI125、150、300、600 JS10、16、20、30、40K PN1.6、4.0、6.4MPa
Nominal Pressure	40-200mm
Connection Type	Flange Types: FF, RF, RJ, LG Standards: ANSI B16.5; JIS B2201 JB/T79.1 PN1.6MPa JB/T79.2 Concave and convex Weld types: Scarf weld (SW) (40-50mm) Butt weld (BW) (65-200mm)
Material	HT200 ZG25 ZG1Cr18Ni9 ZG0Cr17Ni12Mo2 1.25Cr0.5Mo 5.0Cr0.5Mo SCPH21 SCPH61 TI
Upper valve cover	Normal Temperature Type (P):-17~230°C Elongated Type I (E1): -45~17°C 230~566°C Elongated Type II (E2): Integrated Type (E2 I): -100~ -45°C Welded Type (E2 W): -196~ -100°C
Gland type	Bolt-on type
Filler	V-type PTFE packing, PTFE-impregnated asbestos packing, and asbestos braided packing.

Valve internal components

Valve core type	Pressure balanced valve core
Flow characteristics	High-precision flow characteristics High-capacity sleeve flow characteristics
Working Range	Soft valve seat operating temperature and gland Stellite overlay operating temperature and gland
Material	-17-4PH, 0Cr17Ni12Mo2 Stellite overlay welding
Remark	Integral and split sleeves should be determined according to nominal diameter, material and operating temperature.



ACTUATOR

Model	HA Multi-spring diaphragm pneumatic actuator
Diaphragm material	Ethylene Propylene Rubber Clip
Spring range	0.02~0.10、0.08~0.24MPa
Gas supply pressure	0.14、0.16、0.28、0.40MPa
Air source connector	Rc 1/4
Ambient temperature	-30 ~ 70°C
Remark	This valve can also be equipped with VAS and VP actuator
Valve action form	Air-to-open 、 Air-to-close
Accessories	Positioners, retaining valves, handwheel pneumatic valve position transmitters, etc.

Performance

Leakage	Metal valve seat: in accordance with the standard ANSIB16.104 grade II, less than 0.5% of the rated Cv . PTFE valve seat: In accordance with the standard ANSI B16.104 IVgrade, less than the rated Cv10 ⁻⁷
Hysteresis	3% (without positioner); 1% (with positioner).
Linear	±5% (without positioner); ±1% (with positioner).
Adjustable range	50:1
Remark	Using standard V-type polytetrafluoroethylene packing

PCV-VVIVIIVIII -S1N Caged Single Seat Control Valve

CV value and stroke

Nominal diameter (mm)			40			50			65			80			100			150			200		
Valve seat diameter (mm)			25	32	40	32	40	50	40	50	65	50	65	80	65	80	100	100	125	150	125	150	200
Rated Cv value	High capacity sleeve	Equal percentage			36			60			100			140			220			420			820
		Linear			40			75			110			150			240			435			850
	High precision sleeve	11	17	24	17	24	44	24	44	68	44	68	99	68	99	175	175	275	360	275	360	650	
Rate stroke(mm)			25						38						50			75					

NOTE:High-precision metal valve seat flow characteristics comply with IEC534-2

Allowable pressure difference

- I. Metal Valve Seat
A. Air-to-Close Valve

Actuator	Gas supply pressure (MPa)	Spring range (MPa)	Positioner	Allowable pressure difference(MPa)						
				DN 40	DN 50	DN 65	DN 80	DN 100	DN 150	DN 200
HA2D	0.14	0.02-0.10	Have or No	0.99	0.77	0.66	0.54	0.42		
	0.16	0.02-0.10	Have	4 4.92	3.8	3.29	2.74	2.08		
	0.40	0.08-0.24	Have	4 10	4	9.87	4	9.23	4	6.28
HA3D	0.14	0.02-0.10	Have or No	1.75	1.37	1.17	0.97	0.74	0.52	
	0.16	0.02-0.10	Have	4 8.7	4 6.7	4 5.8	4 4.87	3.7	2.61	
	0.40	0.08-0.24	Have			4 10			4 7.86	
HA4D	0.14	0.02-0.10	Have or No			2.02	1.67	1.28	0.90	0.74
	0.16	0.02-0.10	Have			4 10	4 8.39	4 6.36	4 4.5	3.7
	0.40	0.08-0.24	Have						4 10	

Flange distance

DN	ANSI 125FF PN1.6 ANSI 150RF JIS 10K FF RF	JIS 16K RF	ANSI 300 RF JIS 20 30K RF JIS 30 K RF	ANSI 600 RF JIS 40K RF PN6.4	JIS 16K Grooved / Embedded type	JIS 20K Grooved / Embedded type	JIS 30K Grooved / Embedded type	JIS 40K Grooved / Embedded type
40	222	231	235	251	235	236	248	251
50	254	263	267	286	265	267	276	286
65	276	288	292	311	290	292	303	311
80	298	313	317	337	310	317	326	337
100	352	364	368	394	360	368	379	394
150	451	465	473	508	475	473	486	508
200	543	560	568	610	570	568	580	610

PCV-VVIVIIVIII-S2N Pneumatic Diaphragm Straight-through Single-seat Regulating Valve

Overview

- The PCV-VVIVIIVIII-S2N pneumatic diaphragm, straight-through, single-seat control valve is one of the most commonly used actuators in automatic control systems.
- It features a simple structure, reliable operation, low leakage, and resistance to fire and explosion. Therefore, it is widely used in automatic control systems in industries such as petrochemicals, metallurgy, and power plants.
- Because the unbalanced force on the valve core is large, especially with larger diameters, this unbalanced force increases. Therefore, it is suitable for applications where low pressure differentials are required but low leakage is required.



Main technical parameters

Nominal diameter(mm)	G3/4"						20				25	32	40	50	65	80	100	125	150	200
Valve seat diameter(mm)	3	4	5	6	7	8	10	12	15	20	26	32	40	50	65	80	100	125	150	200
Rated flow coefficient Kv	20	20	20	20	20	20	20	20	20	20	8	12	20	32	50	80	120	200	280	450
Flow characteristics	straight line						straight line; equal percentage													
Nominal pressure(MPa)	10						1.6, 4.0, 6.4													
Connection type	Pipe thread connection G3/4"						French connection: PN1.6 according to JB78-59 standard, PN4.0, 6.4 according to JB79-59 standard													
Effective area Fe(cm ²)	200						280				280		400		630		1000			
Stroke L(mm)	10						10				16		25		40		60			
Mode of action	Air-to-close, air-to-open																			
Spring pressure range(KPa)	Standard 20-100, optional 40-200, 20-60, and 60-100																			
Gas supply pressure(MPa)	Standard 0.14; optional 0.24																			
Air source connector	M16 × 1.5																			
Inherent adjustable ratio R	30:1																			

Main technical indicators

Project	Without valve positioner	With valve positioner
Basic error%	≤ ±5	≤ ±1
Hysteresis %	≤ 3	≤ 1
Dead zone%	≤ 3	≤ 0.4
Leakage	0.01% × valve rated capacity	
Rated flow coefficient error %	≤ ±10; when Kv ≤ 5, ≤ ±20	

Valve body material and applicable temperature range

Material	Material grade	Nominal Pressure (MPa)	Applicable TEMP(°C)	
			Normal	Cooling Fins
Cast iron	HT200	1.6	-20~200	
Cast steel	ZG230-450	4.0/6.4	-40~250	-40~450
Cast stainless steel	ZG1Cr18Ni9Ti ZG0Cr18Ni12Mo2Ti	4.0/6.4	-40~250	-60~450

PCV-VVIVIIVIII-S3N Precision Small Pneumatic Diaphragm Straight-through Double-seat Regulating Valve

Overview

- The PCV-VVIVIIVIII-S3N of compact pneumatic diaphragm direct-through double-seat control valves consists of a pneumatic diaphragm multi-spring actuator and a direct-through double-seat valve.
- The valve section is identical to the pneumatic diaphragm direct-through double-seat control valves, offering advantages such as high flow capacity, low unbalanced force, and easy changeover.
- Due to its compact size and light weight, the pneumatic actuator makes it widely used in automation systems in industries such as petrochemicals and textiles, where leakage requirements are less stringent and installation space is limited.



Main technical parameters

Nominal diameter(mm)	25	25	25	25	65	80	100	125	150	200
Valve seat diameter(mm)	26,24	32,30	40,38	50,48	66,64	80,78	100,98	125,123	150,148	200,197
Rated flow coefficient Kv	10	16	25	40	63	100	160	250	400	630
Flow characteristics	straight line; equal percentage									
Nominal pressure(MPa)	1.6 , 4.0 , 6.4									
Connection type	Flange connection; according to JB79-59 standard									
Effective area Fe(cm ²)	350			560			900			
Stroke L(mm)	16	25		40			60			
Mode of action	Air-to-close, air-to-open									
Spring pressure range(KPa)	Standard 20-100, Optional 40-200, 20-60, 60-100									
Gas supply pressure(MPa)	Standard 0.14; optional 0.25 0.4									
Air source connector	M16 ×1.5									
Inherent adjustable ratio R	30:1									

Main technical performance indicators

Project	Without valve positioner	With valve positioner
Basic error%	≤ ±5	≤ ±1
Hysteresis %	≤ 3	≤ 1
Dead zone%	≤ 3	≤ 0.4
Leakage	0.01% × valve rated capacity	
Rated flow coefficient error %	≤ ±10	

P3CV-VVIVIIVIII-SFL/HLN Pneumatic Diaphragm Three-way Regulating Valve

Overview

- The P3CV-VVIVIIVIII-SFL/HLN pneumatic diaphragm three-way regulating valve offers both combining and diverting operation modes.
- The valve core utilizes a cylindrical thin-walled window and is guided from the side of the core.
- Three-way valves can replace to two-way valves and a three-way pipe in certain applications, making them widely used. They are commonly used for two-phase regulation in heat exchangers and can also be used for simple ratio control.



Main technical parameters&performance indicators

Main technical parameters of the regulating mechanism

Nominal diameter (mm)	Confluence	25	32	40	50	65	80	100	125	150	200	250	300
	Diversion						80	100	125	150	200	250	300
Rated flow coefficient Kv	Confluence	8.5	13	21	34	52	85	135	210	340	535	800	1260
	Diversion						85	135	210	340	535	800	1260
Nominal pressure(MPa)	1.6 , 4.0 , 6.4												
Stroke(mm)	16		25		40		60		100				
Flow characteristics	straight line												
Medium temperature(°C)	-20~+200°C, -40~+250°C (normal temperature); -40~+425°C (medium temperature)												
Flange size	Cast iron flange dimensions are in accordance with JB783 cast steel flange dimensions are in accordance with JB79												
Flange type	Flange sealing type is in accordance with JB77, in which cast iron flange is smooth type and cast steel flange is concave type.												
Valve body material	HT200,WCB,ZG1Cr18Ni9Ti												
Valve core material	1Cr18Ni9Ti												
Upper bonnet form	Ordinary type (normal temperature type), thermal sheet type (medium temperature type)												
Adjustable ratio R	30:1												

Main technical parameters of actuator mechanism

Model	ZH _B ^A -22	ZH _B ^A -23	ZH _B ^A -34	ZH _B ^A -45	ZH _B ^A -56
Effective area(cm ²)	350	350	560	900	1400
Stroke(mm)	16	25	40	60	100
Spring range(KPa)	20~100;40~200;20~60;60~100;80~240				

P3CV- V VI VII VIII **-SFL/HLN Precision Small Pneumatic Sleeve Control Valve**

External Dimensions

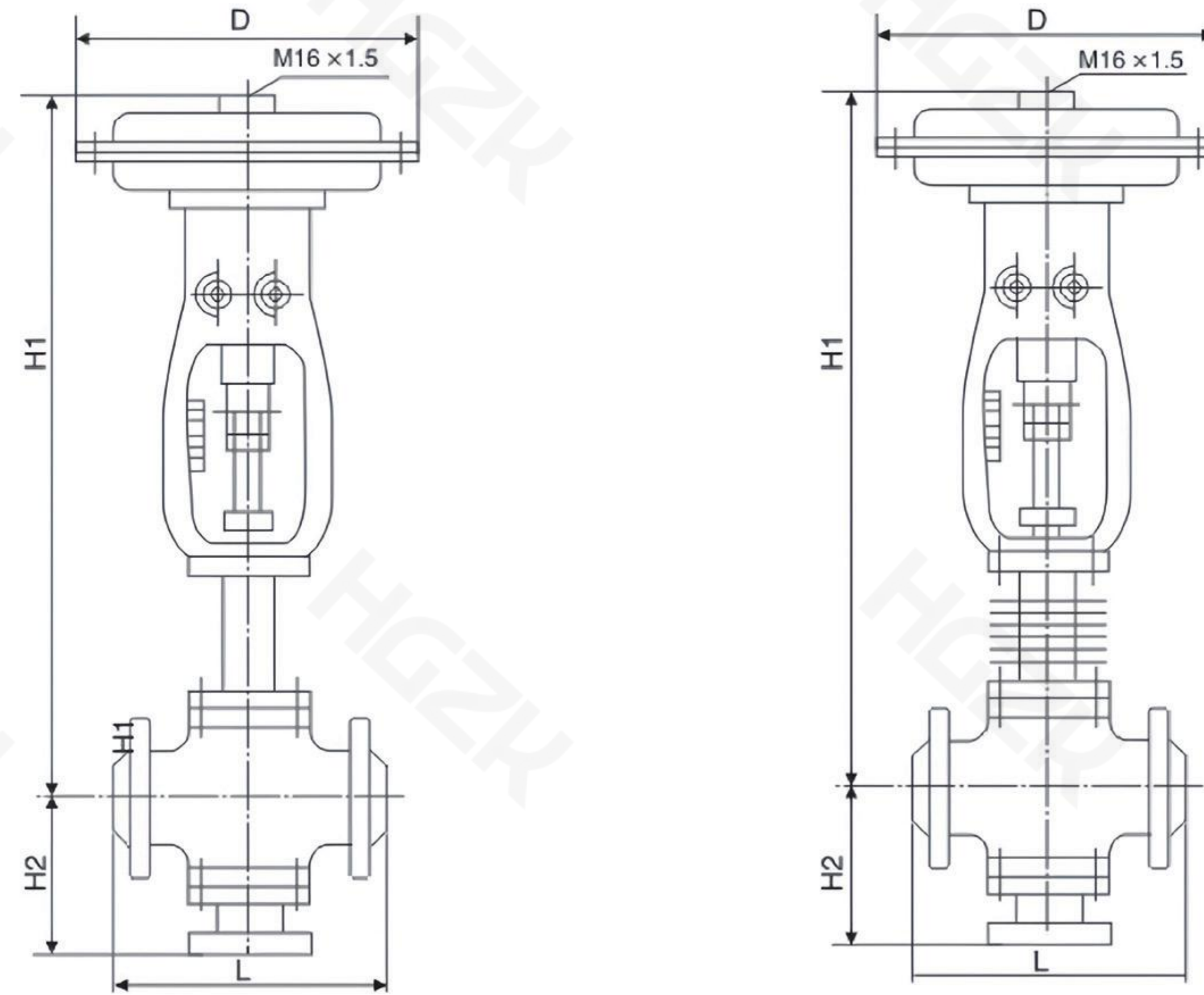

DN	Stroke	D	Confluence						Diversion									
			L			H1		H2			L			H1		H2		
			PN MPa			Normal Temp	Medium Temp	PN MPa			PN MPa			Normal Temp	Medium Temp	PN MPa		
			1.6	4.0	6.4			1.6	4.0	6.4	1.6	4.0	6.4			1.6	4.0	6.4
25	16	325	185	190	200	615	763	160	150	150	185	190	200	615	763	140	150	160
32	16	325	200	200	210	622	773	150	160	160	200	200	210	622	773	150	160	170
40	25	325	220	220	235	625	776	160	170	170	220	220	235	625	776	160	170	180
50	25	325	250	255	265	640	791	180	190	190	250	255	265	640	791	180	190	200
65	40	410	275	285	295	861	1024	200	210	210	275	285	295	861	1024	200	210	220
80	40	410	300	310	320	879	1042	210	230	230	300	310	320	885	1050	225	250	265
100	40	410	350	360	370	873	1036	220	250	250	350	360	370	900	1060	245	275	285
125	60	495	410	430	440	1029	1244	260	300	300	410	430	440	1050	1265	285	320	325
150	60	495	450	465	475	1046	1261	280	320	320	450	465	475	1060	1275	305	340	345
200	60	495	550	560	570	1075	1290	320	380	380	550	560	570	1105	1320	350	400	410
250	100	600	635	660	670	1451	1320		474	474	635	660	670	1525	2800		540	540
300	100	600	720	740	770	1512	1560		584	584	720	740	770	1545	1820		612	612

NOTE: The diverter valve with a nominal diameter less than 80 should be replaced by a converging valve with the same diameter.

Ordering Instructions

When ordering, please fill out the "Specifications" or indicate the following:

1. Product Model
2. Nominal Pressure
3. Nominal Diameter, Rated Flow Coefficient (Kv)
4. Signal Pressure, Spring Range
5. Flow Characteristics
6. Valve Opening/Closing Mode
7. Medium Operating Temperature Range
8. Valve Body and Valve Core Material
9. Accessories Included, and Part Numbers
10. Any Other Special Requirements

PJCV-VVIVIIVIII-S1N Precision Small Pneumatic Diaphragm Angle Control Valve

Overview

- The PJCV-VVIVIIVIII-S1N precision miniature pneumatic diaphragm angle control valve consists of ZH_B^A pneumatic diaphragm multi-spring actuator and an angle valve.
- It is compact and light weight. The valve core utilizes a top-guided structure.
- The flow path within the valve body is simple and free of dead angles, thus preventing coking, sticking, and clogging of the media.
- It also exhibits a certain degree of self-cleaning capability. This product is suitable for regulating high-viscosity media containing suspended matter.



Product Model

Product model	ZH _B ^A S -64	ZH _B ^A S -64G
---------------	------------------------------------	-------------------------------------

Main technical parameters

Nominal diameter(mm)	25				80	100	125	150	200	250	300	300	1260	250
Valve seat diameter(mm)	32	40	50	65	80	100	125	150	200	800	535	340	210	135
Rated flow coefficient Kv	85	52	34	21	13	8.5	8.5	8.5	8.5	8.5	8.5	8.5	8.5	8.5
Flow characteristics	straight line; equal percentage													
Nominal pressure(MPa)	6.4													
Connection type	Flange connection; according to JB79-59 standard													
Matching actuator model	ZH _B ^A -22				ZH _B ^A -23			ZH _B ^A -34			ZH _B ^A -45			
Effective area Fe(cm ²)	350				350			560			900			
Stroke L(mm)	10				16			25			40			
Mode of action	Air-to-close; Air-to-open													
Spring pressure range(KPa)	Standard 20-100, optional 40-200, 20-60, 60-100, 80-240													
Gas supply pressure(MPa)	Standard 0.14; 0.25, 0.40 are optional													
Air source connector	M16 × 1.5													
Adjustable ratio R	30 : 1													

Main technical performance indicators

Model	Without valve positioner	With valve positioner
Basic error%	≤ ±5	≤ ±1
Hysteresis%	≤ 3	≤ 1
Dead Zone%	≤ 3	≤ 0.4
Leakage	0.01% × valve rated capacity	
Rated flow coefficient error%	when Kv > 6.3, ≤ ±10 when Kv < 6.3, ≤ ±15	

Valve body material and applicable temperature range

Valve body material	Cast steel	Cast stainless steel
Material grade	ZG230-450	ZG1Cr18NMTi ZG0Cr18Ni12Mo2Ti
Nominal pressure(Mpa)	6.4	6.4
Applicable temperature range		
Normal temperature type	-40~250°C	-40~250°C
Thermal film type	-40~450°C	-60~450°C

PCV-VVIVIIVIII-LFL/HLN Pneumatic Diaphragm Three-way Regulating Valve

Overview

- The PCV-VVIVIIVIII-LFL/HLN pneumatic diaphragm low-temperature regulating valve consists of a pneumatic diaphragm actuator and a low-temperature-resistant single-seat or double-seat valve.
- The valve utilizes an extended bonnet, ensuring that even at very low temperatures within the valve body, the packing at the upper end remains at room temperature. This product is suitable for regulating media (such as liquid oxygen and liquid nitrogen) at temperatures between -60°C and -250°C. To ensure accurate regulation, a valve positioner is required.



Main technical parameters

Nominal diameter(mm)	25	32	40	50	65	80	100	125	150	200
Valve seat diameter(mm)	26,24	32,30	40,38	50,48	66,64	80,78	100,98	125,123	150,148	200,197
Rated flow coefficient Kv	10	16	25	40	63	100	160	250	400	630
Flow characteristics	straight line; equal percentage									
Nominal pressure(MPa)	1.6 , 4.0 , 6.4									
Connection type	Flange connection: according to JB79-59 standard									
Equipped actuator model	ZMA-2	ZMA-3	ZMA-4				ZMA-5			
Effective area Fe(cm ²)	200	400	630				1000			
Stroke L(mm)	16	25	40				60			
Mode of action	Air-to-close;Air-to-open									
Spring pressure range (KPa)	Standard 20-100, optional 40-200, 20-60, 60-100									
Gas supply pressure (MPa)	Standard 0.14 optional 0.24									
Air source connector	M16 × 1.5									
Adjustable ratio R	30:1									

Main technical performance indicators

Model	without valve positioner	with valve positioner
Basic error%	≤ ±6	≤ ±1.5
Hysteresis %	≤ 5	≤ 1.5
Dead zone%	≤ 4	≤ 0.6
Leakage	0.1% × valve rated capacity	
Rated flow coefficient error %	≤ ±10	

PCV-VVIVIIVIII -LFL/HLN Pneumatic diaphragm low temperature regulating valve

Valve body material and applicable temperature range

Valve body material	Low temperature steel	Cast stainless steel
Material grade	LCB	ZG1Cr18Ni9Ti
Nominal pressure	1.6 ,4.0, 6.4	
Select flange		
Flange size	According to PN1.6 JB78-59 standard	
Sealing surface size	Concave and convex press JB79-59; PN4.0	
Applicable temperature range	-46 ~ -200°C	-60 ~ -250°C

Allowable pressure difference

The recommended working pressure difference of the standard assembled pneumatic diaphragm low-temperature two-seat regulating valve is no more than 1MPa. When the pressure difference exceeds the allowable value, the unbalanced force can be overcome by adjusting the spring preload, using a valve positioner or selecting other actuators.

Flange distance

DN(mm)	25	32	40	50	65	80	100	125	150	200	
Φ A	280		325		410			495			
Φ	235	255	280	310	345	370	430	490	550	660	
Φ 1	260	285	305	340	375	405	460	525	590	700	
Φ 2	290	315	335	370	410	440	490	560	630	740	
n-Φ	8-14		8-16		10-16	10-18	12-18	16-18		20-18	
L	185	200	220	250	275	300	350	410	450	550	
H2	104	107	126	131	175	190	202	250	260	302	
H	H1=500	1052	1055	1135	1140	1374	1389	1401			
	H1=600	1152	1155	1235	1240	1474	1489	1501			
	H1=700	1252	1255	1335	1340	1574	1589	1601	1750	1760	1800
	H1=800	1352	1355	1435	1440	1674	1689	1701	1850	1860	1900
	H1=900	1452	1455	1535	1540	1774	1789	1801	1950	1960	2000
	H1=1000	1552	1555	1635	1640	1874	1889	1901	2050	2060	2100
	H1=1100								2150	2160	2200
	H1=1200								2250	2260	2300

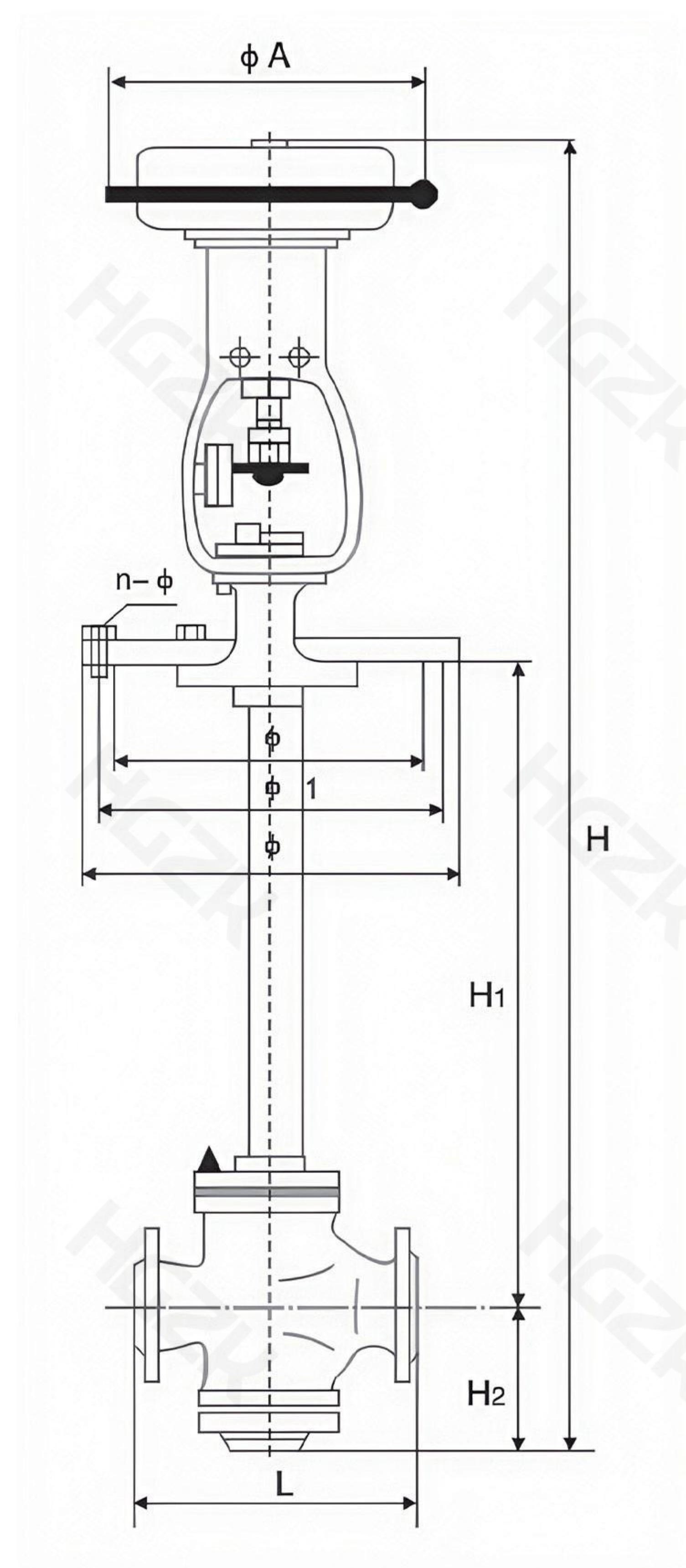

PCV-VVIVIIVIII-B1NPneumatic Diaphragm Fluorine-lined Bellows Regulating Valve

Overview

Pneumatic diaphragm and bellows regulating valve is the executive unit in the automation instrument system. It is installed on the medium conveying pipeline and used in conjunction with other instruments to control parameters such as flow. In addition to reliable sealing, it is also unique in being resistant to strong corrosive media such as acids (hydrochloric acid, sulfuric acid, hydrofluoric acid) and alkalis. It is suitable for regulating highly toxic, precious, volatile, and permeable media. Therefore, it is widely used to regulate flow in industrial automation devices such as chemical industry, petroleum, metallurgy, medicine, and light textile.



Main technical parameters

Nominal diameter(mm)	3/4"	20	25	32	40	50	65	80	100
Nominal pressure(MPa)	1.0, 1.6								
Valve seat diameter(mm)	3-4	10							
	5-6	15	26	32	40	50	66	82	102
	7-8	20							
Rated flow coefficient Kv	0.08~0.12	1.2							
	0.20~0.32	3.2	8.0	12.0	20.0	32.0	50.0	70.0	100
	0.50~0.80	5.0							
Inherent flow characteristics	straight line	Straight line, equal percentage							
Allowable pressure difference MPa	Nominal pressure	0.80	0.50	0.50	0.30	0.25	0.20	0.12	
Stroke(mm)	10	10	16	25		40			
Operating temperature°C	-30 ~ 200°C								
Valve body material	Carbon steel(WCB), lined with F46(FEP)								
Valve seat, valve core material	2CR13 lining F46 (FEP) Hastelloy; Monel								
Bellows material	Polytetrachloroethylene (PTFE) Hastelloy								
Applicable media	Hydrochloric acid, sulfuric acid, hydrofluoric acid, alkali and highly toxic, volatile media								
Equipped pneumatic actuator	ZM _B ^A -1	ZM _B ^A -2		ZM _B ^A -3		ZM _B ^A -4			
Effective area cm ²	200	280		400		630			
Mode of action	Air-to-close			Air-to-open					
Signal pressure	0.02~0.1			0.04~0.2					
Basic error%	± 10								
Hysteresis%	8								
Dead Zone%	6								
Rated flow coefficient error%	≤ ±10 (±15% when Cv≤5)								
Fixed flow characteristic error%	≤ ±10 (±15% when Cv≤5)								
Allowable leakage	≤1 x 10 ⁻⁴ Cv								

Note: 20~100KPa valve core is in the flow open state, when closed, the pressure after the valve P2=0

PYCV-VVIVIIVIII-S1D Pneumatic Diaphragm Y-type Steam Trap

Overview

- The PYCV-VVIVIIVIII-S1D series pneumatic diaphragm Y-type steam trap is a new generation steam trap specially developed, designed, and manufactured by our company for thermal power plant equipment. Its near-linear flow design reduces flow resistance and utilizes a secondary throttling principle to minimize erosion and extend its service life.
- The valve core and seat are constructed of solid carbide, ensuring internal leakage to \leq Class VI. A removable center seal eliminates external leakage and facilitates maintenance. It can also be used in flammable and explosive environments. Signals from control systems or regulating instruments can be used to open or close the valve, achieving the desired controlled parameters.
- It is widely used for remote control in thermal power plants and other industries. This product is available in direct-acting and reverse-acting versions. Its nominal diameters range from 20 to 100 DN (mm).
- Nominal pressure ratings range from 150 lb (2.0 MPa) to several levels.
Air source power (MPa) ranges from 0.14 to 0.4 MPa.
- Signal ranges (Pr) (kPa) range from 20 to 100 and 40 to 200 kPa. Leakage is near zero. This product is available in a variety of sizes.



Main technical performance indicators

1	Valve body
2	Valve core
3	Pressed sleeve
4	Valve stem
5	Upper valve cover
6	Round nut
7	Packing gland
8	Bracket
9	Putter
10	Actuator

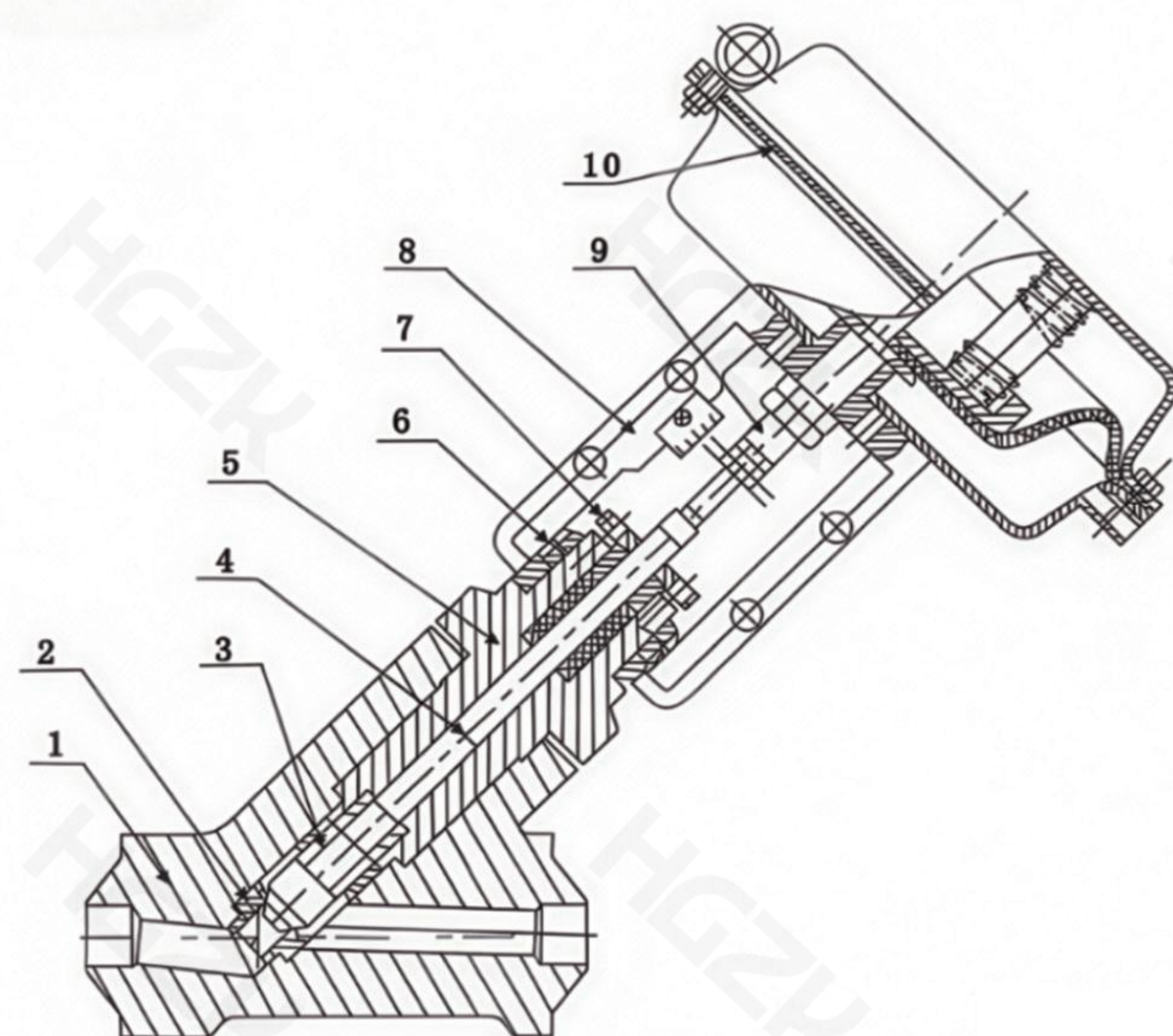

PYCV-5CPF-S1D Pneumatic Diaphragm Y-Type Steam Trap:

This valve consists of a new series pneumatic diaphragm actuator and a Y-type steam trap.

The Y-type steam trap features a specially designed regulating valve body with welded ends, suitable for specific piping configurations.

The actuator has two operating modes: direct and reverse.

When the signal pressure increases, the push rod extends out of the diaphragm chamber, creating an air-to-close operation.

When the signal pressure increases, the push rod retracts into the diaphragm chamber, creating an air-to-open operation.

PVCV-VVIVIIVIII Pneumatic V-type Regulating Ball Valve

Overview

- The PVCV-VVIVIIVIII pneumatic V-shaped ball valve utilizes a V-shaped ball core, enabling linear adjustment over a wide adjustment range. When closed, the shearing action created by the V-shaped notch against the valve seat provides self-cleaning, effectively preventing seizure and making it particularly suitable for pipelines with scale or freezing.
- This valve is suitable for handling suspensions containing fibers and particles, as well as powdery media such as pulp and sewage. It is equipped with a ZGH series pneumatic cylinder actuator, offering a simple structure and high output torque.
- Available in soft and hard seal types, the regulating type is double-acting, while the shut-off type is available in single and double-acting.
- The single-acting valve automatically opens and closes in the event of a power failure, ensuring system safety. It is widely used in the power, petroleum, chemical, paper, food pharmaceutical, and aerospace industries.



Main technical parameters

Model	Straight-through cast ball valve													
Nominal diameter(mm)	25	32	40	50	65	80	100	125	150	200	250	300	350	400
Valve seat diameter	20	26	33	40	53	66	86	104	128	170	212	255	300	340
Rated flow coefficient Kv	25	36	63	100	184	280	400	600	950	1540	2500	3900	6150	9800
Nominal Pressure	PN1.6 / 6.4MPa													
Leakage	Soft seal: $\leq 1.8 \times 10^{-7} \times \Delta P \times DN.1/h$ (test medium is liquid; ΔP is the pressure differential) Hard seal: $\leq 10^{-4} \times$ valve rated capacity.1/h (for calculation of valve rated capacity, see the attached table)													
Air source pressure	0.4~0.6MPa													
Connection type	Wafer type, flange type, pipe flange according to JB79-59 standard													
Applicable temperature	Soft seal -40°C~+180°C; Hard seal -40°C~+450°C													
Core corner	90°													
Flow characteristics	Approximately equal percentage (see the appendix for typical curves)													
Valve body material	A105、F321、F316、WCB、ZG1Cr18NiTi、ZG0Cr18Ni12MO2Ti、ZG00Cr17Ni14Mo2													
Core form	Some balls have V-shaped notches													
Valve seat material	PTFE, stainless steel, Stellite, carbide													
Basic error	$\leq \pm 2\%$ of full stroke (with positioner)													
Hysteresis	$\leq 2.0\%$ of full stroke (with positioner)													
Dead Zone	$\leq 0.8\%$ of full stroke (with positioner)													
Rated flow coefficient error%	$\leq \pm 10$													

Main accessories

Regulating type: Electric valve positioner, air filter pressure reducer, handwheel mechanism, etc.

Quasi-shutoff type: Air filter pressure reducer, solenoid valve, valve position switch, handwheel mechanism, etc.

PCV-VVIVIIVIII-S1D Pneumatic Piston Cut-off Valve

Overview

- The PCV-VVIVIIVIII-S1D pneumatic piston shut-off valve (referred to as a piston-type shut-off valve) is available as a straightthrough single-seat shut-off valve or a straight-through sleeve shut-off valve . It serves as the actuator in pneumatic unit combination instruments.
- It receives signals from a regulating instrument to control the shutoff and connection of fluids within process pipelines or to switch flow paths. This product features high operating force, a novel valve body design, low flow resistance, a high rated flow coefficient, a large allowable differential pressure, and excellent sealing performance.
- As a result, it is widely used in production process automation and process control systems in industries such as petroleum, chemical, metallurgy, power, and textiles.



Main technical parameters of cutting mechanism

Nominal diameter(mm)	20	25	32	40	50	65	80	100	125	150	200
Valve seat diameter(mm)	26	43	43	52	62	79	94	115	140	166	216
Rated flow coefficient Kv	6.5	10	15	25	40	65	100	150	260	350	540
Nominal pressure(MPa)	4.0 , 6.4										
Stroke (mm)	16		25			40			60		
Medium temperature °C	-20~150(normal temperature);-20~450(medium temperature) -20~550(high temperature);-250~-60(low temperature)										
Flow characteristics	Two-position quick-open										
Equipped with actuator	ZSD-2		ZSD-3			ZSD-5			ZSD-7		
Flange size	Press JB79-59										
Flange type	Flange sealing type: JB77 concave type										
Valve body material	ZG230-450,ZG1Cr18Ni9Ti,ZG0Cr18Ni12Mo2Ti,CF8M(-254°C)										

Main technical parameters of cutting mechanism

Model	ZSD-2	ZSD-3	ZSD-5	ZSD-7
Piston diameter mm	15	200	300	400
Effective area cm ²	175	305	700	1246
Stroke mm	10;16	25	40	60
Vent thread	M16 × 1.5	M20 × 1.5		≤ 0.6
Maximum output force N	7200	12800	29300	52000
Operating air pressure	500			

PCV-VVIVIIVIII Pneumatic Regulating Butterfly Valve

Overview

The PCV-VVIVIIVIII Pneumatic regulating butterfly valves offer a simple structure, easy operation, light weight, large diameter, high flow capacity, and self-cleaning capabilities.

They are suitable for regulating fluids containing suspended particles and concentrated, turbid slurries. They are widely used in automated regulation and remote control of production processes in industries such as petroleum, chemical, power plants, textiles, and papermaking, controlling process parameters such as liquid level, flow, and pressure.



Main technical parameters

Nominal diameter(mm)	50	80	100	125	150	200	250	300	350	400	450	500	600	700	800	900	1000
Rated filling factor Kv	85	220	340	530	770	1360	2130	3060	4160	5450	6900	8500	12200	16600	21700	27540	34000
Nominal pressure MPa	0.6																
Corner range	70°																
Signal pressure KPa	20~100																
Flow characteristics	Approximately equal percentage																
Medium temperature °C	-20~200(Normal temperature).-29~425(Medium temperature). -40~570(High temperature)																
Take-over flange	According to JB78 wafer flange connection																
Signal connection screw hole	M16×1.5																
Equipped actuator																	
Thin film	ZMA-2			ZMA-3			ZMA-4			ZMA-5							
Piston type													ZSC-45				
Valve body material	WCB(ZG230-450), 1Cr18Ni9,ZG1Cr18Ni9Ti, ZG0Cr18Ni12Mo2Ti																

Main technical parameters of diaphragm actuator

Model	ZMA-2	ZMA-3	ZMA-4	ZMA-5
Effective area cm ²	280	400	630	1000
Stroke mm	16	25	40	60
Spring range KPa	20~100 ; 40~200 ; 20~60 ; 60~100			

Main technical parameters of piston actuator

Model	Piston diameter mm	Effective area cm ²	(Max) stroke	(Max) operating pressure	(Max) output force N
ZSC-45	250	484	60	500	21800

PCV-VVIVIIVIII-S1N Pneumatic Diaphragm Shut-off Valve

Overview

The ZMQ and ZSQ pneumatic diaphragm (piston) shut-off valves feature a top-guided structure and a multi-spring actuator. They offer advantages such as compact structure, light weight, sensitive operation, S-shaped streamlined fluid passages, minimal pressure drop, large valve capacity, and easy assembly and disassembly. They receive signals from regulating instruments to shut off, open, or redirect the flow of media, achieving automatic control of process parameters such as pressure, flow, and liquid level. They are widely used in production process automation and process control systems across various industries, including petroleum, chemical, metallurgy, electric power, light industry, and textiles.



Feature

The shut-off valve utilizes a multi-spring actuator connected to the regulating mechanism via three vertical rods, reducing overall height and weight by approximately 30%. The valve body is designed using fluid dynamics principles to create a uniform, low-resistance flow path, increasing the rated flow rate by 30%. The valve trim seals are available in two types: tight and soft seals. The tight seal is constructed of welded carbide, while the soft seal is constructed of a soft material, providing excellent shut-off and sealing performance. The balanced trim increases the shut-off valve's allowable differential pressure. The bellows seal provides a complete seal against the moving stem, eliminating any possibility of media leakage. The piston actuator offers high operating force and a high differential pressure.

Main technical parameters

Nominal diameter(mm)		15	20	25	32	40	50	65	80	100	125	150	200
Rated flow coefficient	Sleeve			11	20	30	48	75	120	190	300	480	760
	Single seat	5	7										
Rated stroke(mm)		8			12			20		25	40		50
Allowable leakage	Hard seal (l/h)	Sleeve 5×10^{-5} x valve rated capacity; Single seat 1.2×10^{-7} x valve rated capacity											
	Soft seal (ml/min)	Level VI											
Hard seal temperature °C		Flange connection: according to JB79-59 standard											
Diaphragm effective area(cm ²)		100			200			400		600	1000		
Nominal Pressure(MPa)		1.6 6.4											
Allowable pressure difference	Sleeve	6.4	6.4	3.8	2.5	2.9	1.8	2.0	1.3	0.83	0.8	0.55	0.52
	Single seat	6.4											
Signal pressure(KPa)		200(Thin film)											
Valve body		WCB ZG1Cr18Ni9T											
Valve plug sleeve		1Cr18Ni9Ti,0Cr18Ni12Mo2Ti											
Valve core, valve seat		1Cr18Ni9Ti,0Cr18Ni12Mo2Ti											
Filter		PTFE, Flexible graphite											

Standard accessories

Air filter pressure reducer, solenoid valve, valve position feedback device, etc.

PCV- V VI VII VIII **-S1N Pneumatic diaphragm shut-off valve**
Pneumatic diaphragm three-way shut-off valve

External diemnsions

Nominal diameter	15	20	25	32	40	50	65	80	100	125	150	200
Rate flow coefficient	5	8	12	17	29	43	70	110	165	275	440	690
A(mm)	194			230			306			394	495	
L(mm)	PN16	150	160	180	200	230	290	310	350	400	480	600
	PN64	230			260			300	340	380	430	500
D(mm)	PN16	95	105	115	140	150	165	185	200	220	250	340
	PN64	105	130	140	155	170	180	205	215	250	295	415
H2(mm)	325			346	360	369	477	517	540	742	822	877

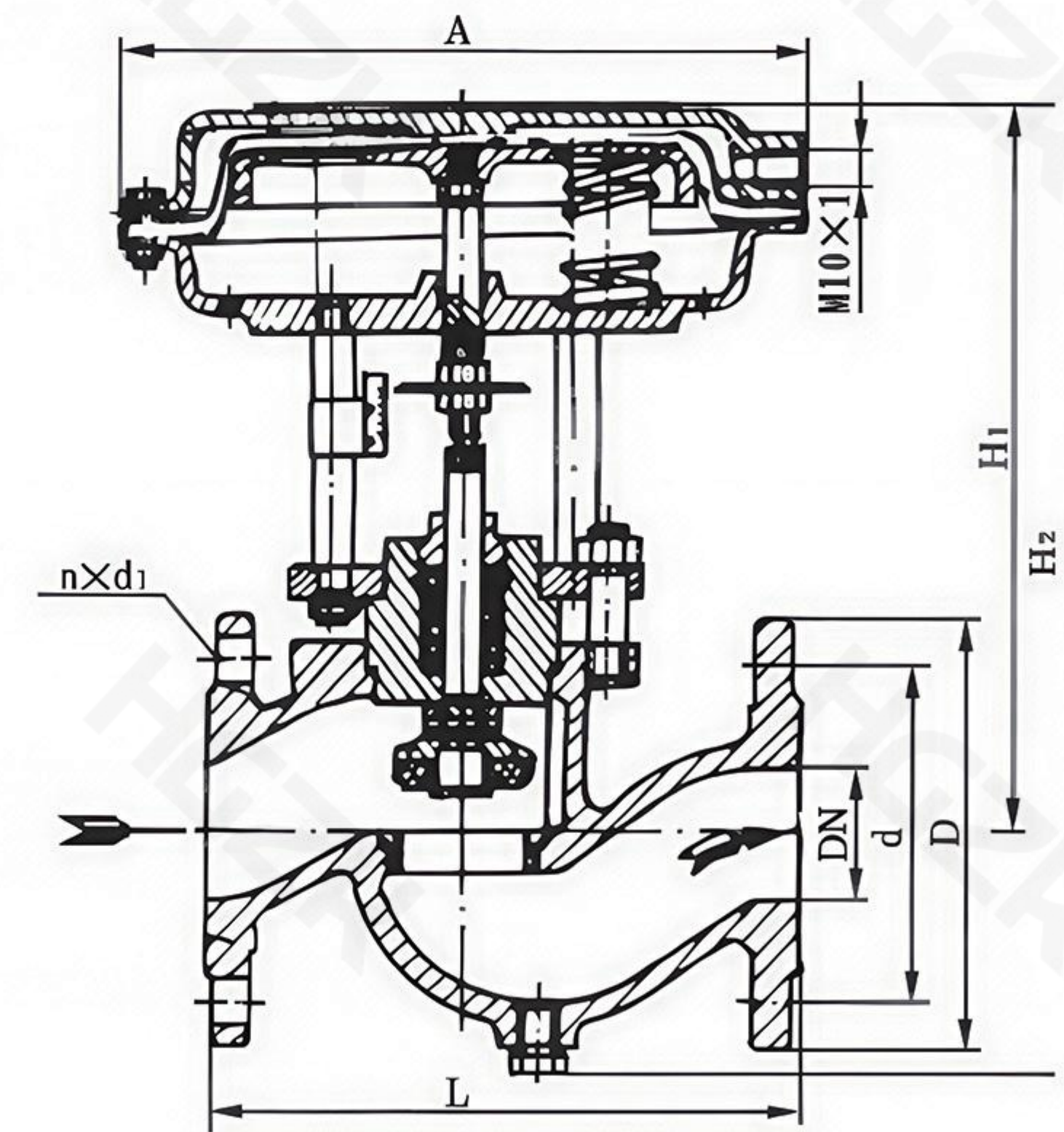

External diemnsions

Nominal diameter	20	25	32	40	50	65	80	100	125	150	200	
Rate flow coefficient	8	12	17	29	43	70	110	165	275	440	690	
H3(mm)	398	392	404	427	443	532	558	577	728	940	995	
A(mm)	194			230			306			394	495	
L(mm)	PN16	150	180	180	200	230	290	310	350	400	480	600
	PN64	230		260		300	340	380	430	500	550	650
D(mm)	PN16	105	115	140	150	165	185	200	220	250	285	340
	PN64	130	140	155	170	180	205	215	250	295	345	415

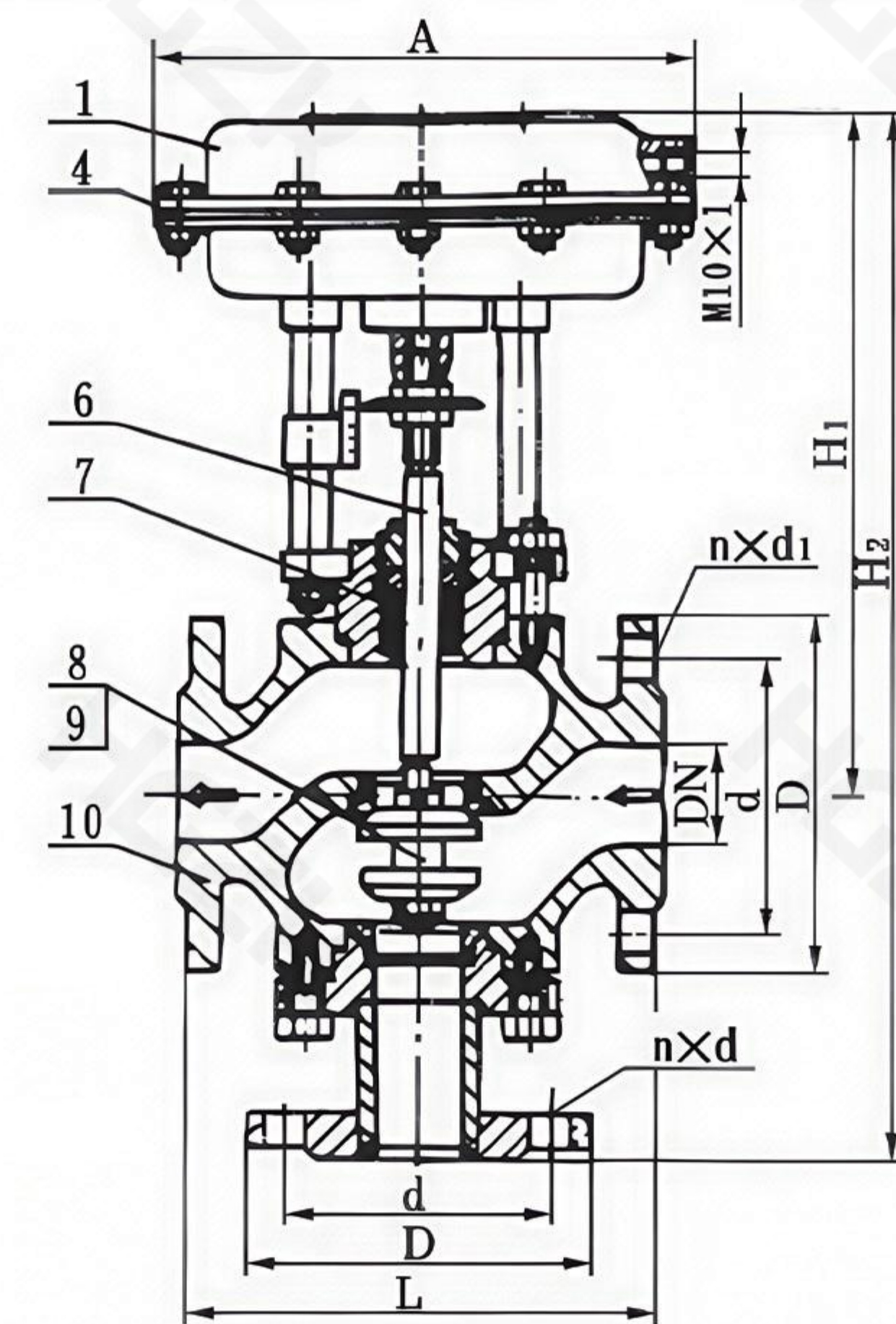

Ordering informations

When ordering, please fill out the "Specifications" or specify the following:

1. Product Model
2. Nominal Diameter
3. Nominal Pressure
4. Operating Medium
5. Medium Temperature
6. Valve Body and Core Material
7. Permissible Pressure Differential
8. Accessories

ECV-VVIVIIVIII-S2DLC Electric Straight-through Single-seat Regulating Valve

Overview

This actuator utilizes servo drive technology and is equipped with our independently developed V4.2 control system and A8.2 operating system, offering highly customizable functionality. Its commissioning process is perfectly aligned with valve requirements and is user-friendly.

- The incremental encoder ensures high precision and stability;
- The stroke setting can be adjusted freely within the valve's full mechanical travel range (including opening and closing directions);
- Flexible combinations of input and feedback signals are possible (e.g., 4–20mA input, M-BUS or 0–10V feedback; M-BUS is customizable);
- Three thrust adjustment levels are supported;
- Heating function allows operation below -20°C to maintain the motor and circuit board's temperature.



Main technical parameters

Nominal diameter(mm)	G3/4"						20				25	32	40	50	65	80	100	125	150	200										
Valve seat diameter(mm)	3	4	5	6	7	8	10	12	15	20	26	32	40	50	66	80	100	125	150	200										
Rated flow coefficient Kv	0.08	0.12	0.2	0.32	0.5	0.8	1.2	2	3.2	5	8	12	20	32	50	80	120	200	280	450										
Flow characteristics	Straight line						Straight line; equal percentage																							
Nominal pressure	10						1.6 4.0 6.4																							
Connection type	Pipe thread connection G3/4"						Flange connection: PN1.6; PN4.0, PN6.4 according to JB79-59 standard																							
Matching actuator	DLC/381/DL/DSL																													
Output thrust	250						250				4000				4000				6400				6400							
Stroke L(mm)	10						16				25				40				60											
Full travel time (s)	20						20				8				12.5				20				32				37			
Mode of action	Electric open type (K) : Electric close type (B)																													
Output signal	0-10mA 4-20mA DC																													
Power supply	220V ; 50-60Hz																													
Inherent turndown ratio R	30:1																													

Main technical performance indicators

Project	Technical performance indicators
Basic error%	≤ ±5
Hysteresis%	≤ 3
Dead zone%	≤ 5
Leakage	0.1% × valve rated capacity
Rated flow coefficient error	≤ ±10; when Kv≤6.3, ≤±15

ECV-VVIVIIVIII-S3DLC Electric Straight-through Double-seat Regulating Valve

Overview

DSL/DL Actuator utilizes servo drive technology and is equipped with the independently developed V4.2 control system and A8.2 operating system, offering flexible customization. Its debugging process aligns with valve requirements and is user-friendly.

- 17-bit mechanical multi-turn absolute encoder, battery-free, high precision, and retains position after power restart.
- Stroke adjustable within the full mechanical range, including open/close direction.
- Speed adjustable from 30% to 100% of maximum.
- Input and feedback signals can be flexibly combined (e.g., 4–20mA input with M-BUS or 0–10V feedback).
- Three thrust grades available.
- Built-in heating function activates below -20°C to protect motor and PCB.
- Zero offset function optional.



Main technical parameters

Nominal diameter(mm)	25	32	40	50	65	80	100	125	150	200	250	300
Valve seat diameter(mm)	26,24	32,30	40,38	50,48	66,64	80,78	100,98	125,123	150,148	200,197	252,248	303,297
Rated flow coefficient Kv	10	16	25	40	63	100	160	250	400	630	1000	1600
Flow characteristics	Straight line; equal percentage											
Nominal pressure	1.6 4.0 6.4											
Connection type	Flange connection: PN1.6, 4.0, 6.4 according to JB79-59 standard											
Matching actuator	DSL/DL/381/DLC											
Output thrust	4000			6400			6400			16000		
Stroke L(mm)	20		25		40		60		100			
Full travel time (s)	12.5		20		32		37		62			
Mode of action	Electric open type (K) : Electric close type (B)											
Output signal	0-10mA 4-20mA DC											
Power supply	220V ; 50-60Hz											
Inherent turndown ratio R	30:1											

Main technical performance indicators

Project	Technical performance indicators
Basic error%	≤ ±5
Hysteresis%	≤ 3
Dead zone%	≤ 5
Leakage	0.1% × valve rated capacity
Rated flow coefficient error	≤ ±10

ECV-VVIVIIVIII-S2381 Electronic Electric Single-seat Regulating Valve

Overview

The ECV-VVIVIIVIII-S2381 electronic electric single-seat regulating valve is composed of a 381L series electronic electric actuator and a single-seat regulating mechanism. The electric actuator is equipped with a servo system, so no separate servo amplifier is required. It can be controlled by input signals and power supply. The wiring is simple, and the valve core of the regulating mechanism adopts top guidance. It is suitable for occasions with strict requirements on leakage, low pressure difference before and after the valve, and certain viscosity and fiber-containing media.



Main technical parameters and performance indexes

Main technical parameters of single-seat adjustment mechanism

Nominal diameter(mm)	G3/4"						20				50	65	65	80	200	200	100	125	150	200
Valve seat diameter(mm)	3	4	5	6	7	8	10	12	15	20	26	32	40	50	66	80	100	125	150	200
Rated flow coefficient Kv	0.08	0.12	0.20	0.32	0.5	0.8	1.2	2.0	3.2	5.0	8.0	12	20	32	50	80	120	200	280	450
Nominal Pressure(MPa)	1.6, 4.0, 6.4 (normal temperature), 4.0, 6.4 (medium temperature), 0.6, 4.0, 6.4 (low temperature)																			
Stroke(mm)	10						16				25				40				50	
Movement speed	4.2						2.1				3.5				1.7				3.4	
Flow characteristics	Straight line						Straight line, equal percentage													
Medium temperature °C	-20~+200, -40~+250 (normal temperature), -20~+450 (medium), -250~-60 (low temperature)																			
Flange size	Cast iron flange according to JB79-59																			
Flange type	Flange sealing surface type is in accordance with JB77-59, cast iron flange is smooth, cast steel flange is concave, low temperature flange is tongue and groove.																			
Nominal Pressure (MPa)	0.6						Low temperature -250 ~ -60°C ZG1Cr18Ni9Ti CF8M													
	1.6						Normal temperature -20~200°C HT200													
	4.0						Normal temperature-20~200°C WCB ZG1Cr18Ni9Ti													
							Medium temperature -20~450°C WCB ZG1Cr18Ni9Ti													
							Low temperature -250~-60°C ZG1Cr18Ni9Ti-196°C)CF8M(-250°C)													
	6.4						Normal temperature -20-200°C WCBZG1Cr18Ni9Ti													
Medium temperature -20-450°C WCB ZG1Cr18Ni9Ti																				
Low temperature -250~-60°C ZG1Cr18Ni9Ti-196°C)CF8M(-250°C)																				
Valve core material	Cr18Ni9\F316(0Cr18Ni12Mo2)																			
Upper bonnet form	Normal type (normal temperature), hot plate type (medium temperature), long neck type (low temperature)																			
Equipped electric actuator model	PTFE, Flexible graphite						0.83				0.83				0.83				0.83	
	PTFE, Flexible graphite						0.83				0.83				0.83					

Note: We can provide users with products of foreign flange standards such as ANSI, JPI, JIS, etc., and their structural length is determined according to user needs.

ECV- V VI VII VIII -S2381 Electronic Electric Single-seat Regulating Valve

Flow characteristics diagram

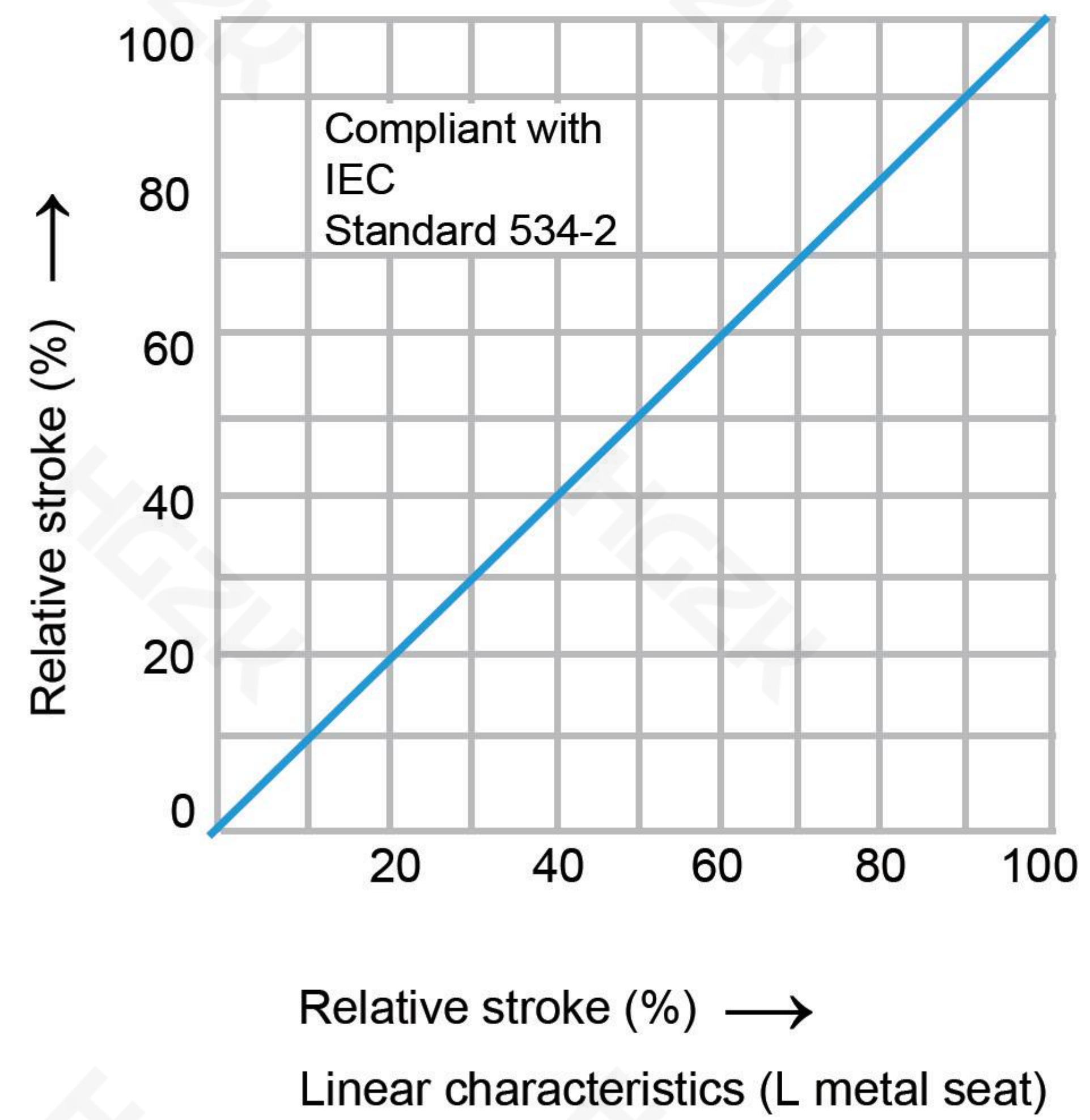
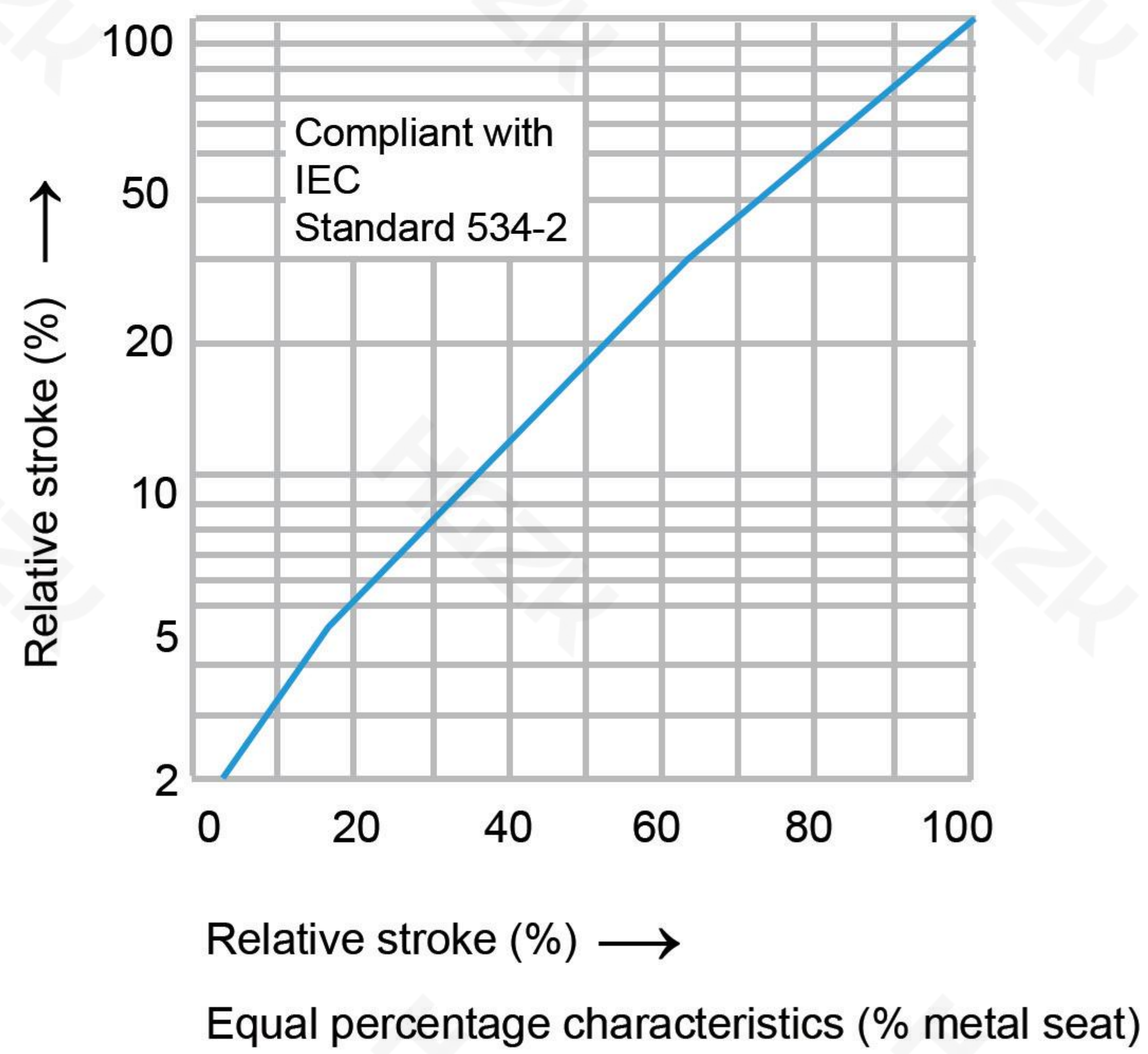

Dimensions

mm

DN (mm)	L			H Normal	Flange standard is according to JB79-1994 PN1.6MPa					
	PN16	PN40	PN64		D	D1	D2	b	I1	N - Φ
DN25	184	197	210	420	115	85	65	14	2	4-14
DN32	200	205	215	480	135	100	78	16	2	4-18
DN40	222	235	251	600	145	110	85	16	3	4-18
DN50	254	267	286	670	160	125	100	16	3	4-18
DN65	276	292	311	830	180	145	120	18	3	4-18
DN80	298	317	337	835	195	160	135	20	3	8-18
DN100	352	368	394	860	215	180	155	20	3	8-18
DN150	451	473	508	1065	280	240	210	24	3	8-23
DN200	600	620	650	1110	335	295	265	26	3	12-23
DN250	650	680	703	1225	405	355	320	30	3	12-25
DN300	740	760	772	1285	460	410	375	30	4	12-25
DN350	845	900		1375	520	470	435	34	4	16-25

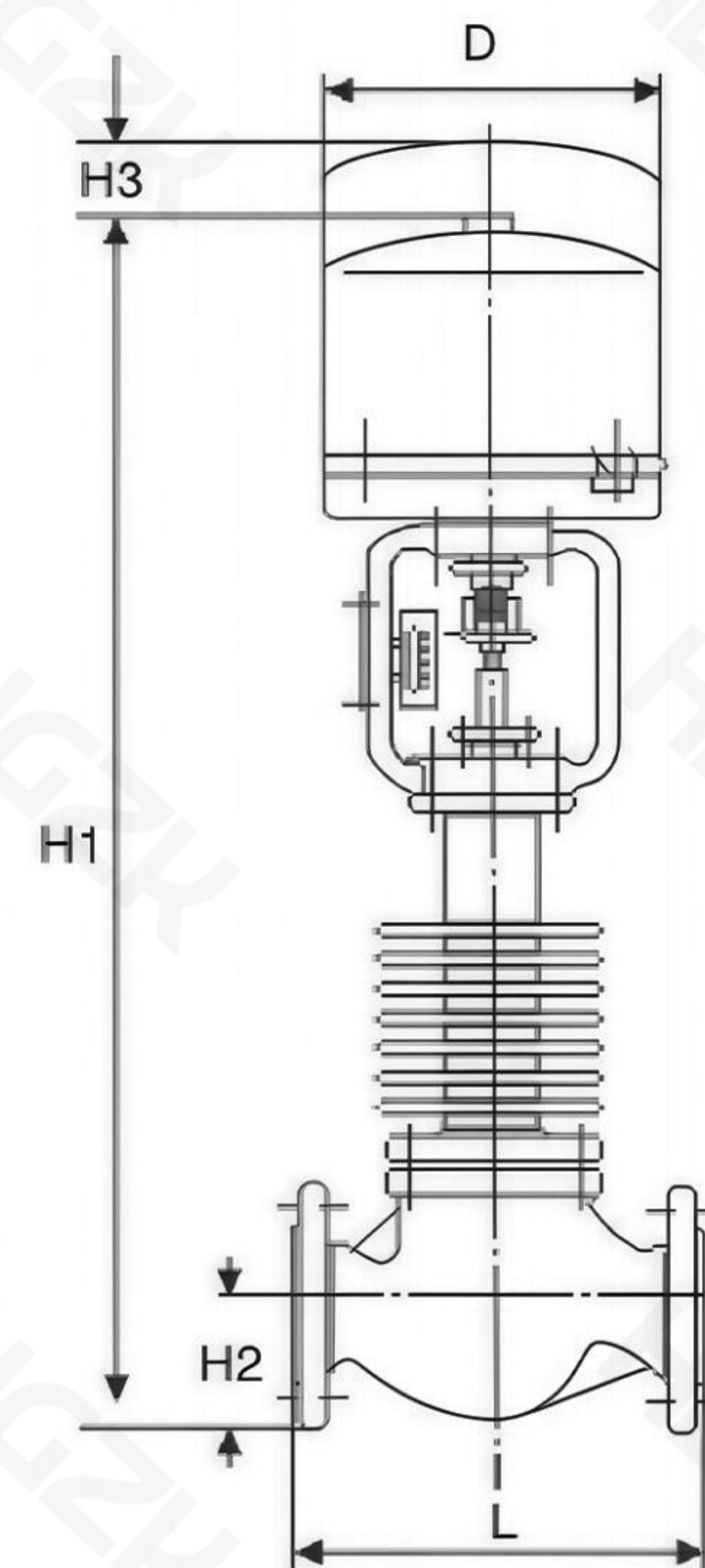
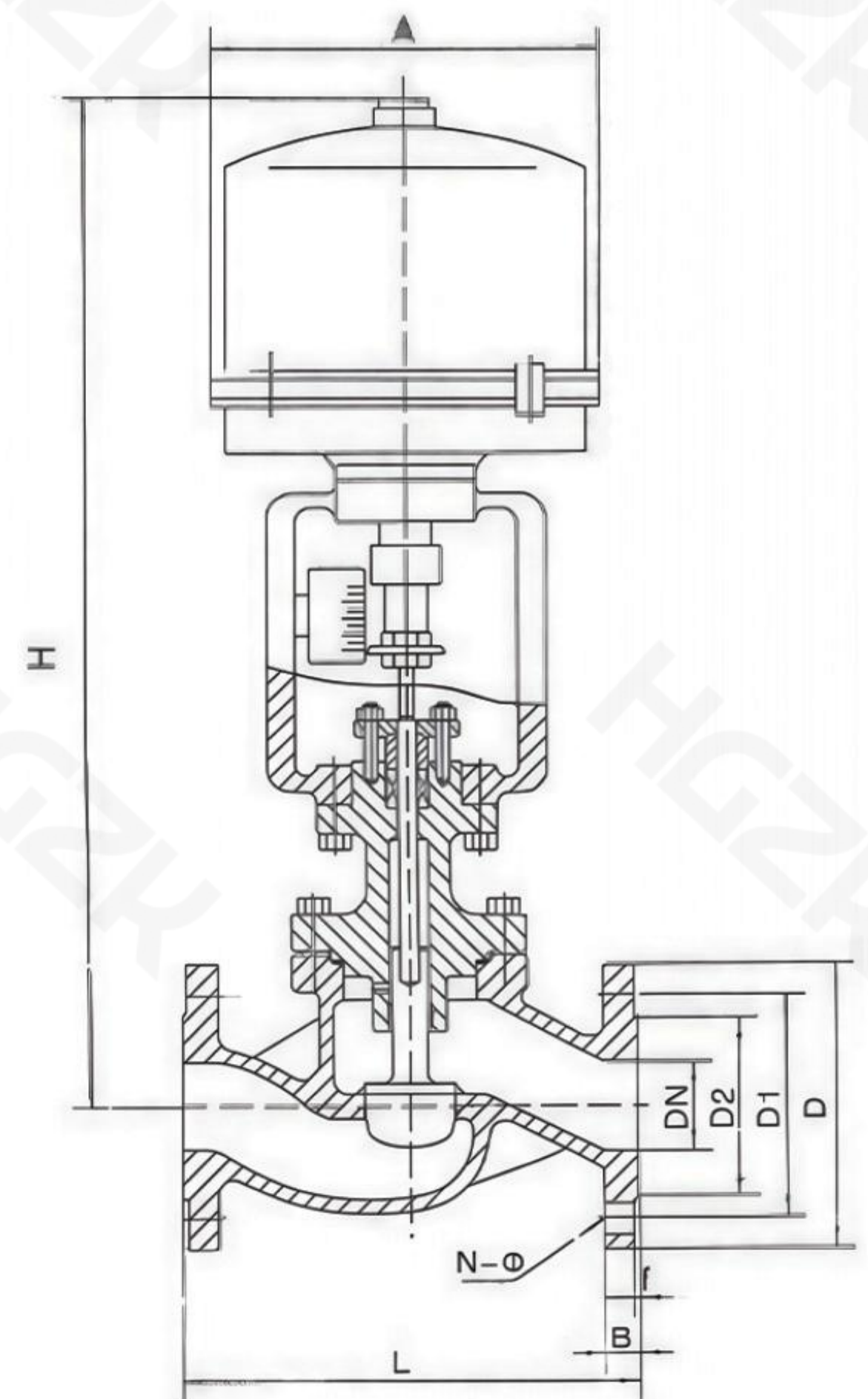

ECV-VVIVIIVIII-S2381 Electronic Electric Sleeve Regulating Valve

Overview

The ZDLM electronic, electric sleeve control valve receives a DC current signal from a regulating instrument, changes the flow rate of the regulated medium, and maintains the controlled process parameters at a given value. It is widely used in production automation control in industries such as power, metallurgy, chemicals, petroleum, textiles, pharmaceuticals, and papermaking. This series of valves has nominal diameters ranging from 20 to 300 mm and nominal pressures of 1.6, 4.0, and 6.4 MPa. It accepts signals of 0 to 10 mA.DC or 4 to 20 mA.DC, and has an operating turbidity range of -40°C to 450°C. These electric sleeve control valves are suitable for applications with large pressure differentials and high leakage rates.



Main parts materials

Valve body and bonnet: HT200, ZG230-450, ZG1Cr18Ni9Ti
 Valve core: 1Cr18Ni9Ti, Stilbene alloy overlay, reinforced PTFE
 Padding: PTFE, flexible graphite, stainless steel bellows
 Push rod and bushing: 2Cr13
 Gasket: Rubber asbestos sheet, 1Cr18Ni9Ti, graphite spiral wound gasket

Main technical parameters

Nominal diameter(mm)		20				25	32	40	50	65	80	100	125	150	200	250	300
Rated flow coefficient Kv	Straight	1.8	2.8	4.4	6.9	11	17.6	27.5	44	69	110	176	275	440	690	1100	1760
	Equal percentage	1.6	2.5	4	6.3	10	16	25	40	63	100	160	250	400	630	1000	1600
Rated stroke(mm)		10				16	25			40			60		100		
Nominal Pressure(MPa)		1.6、 4.0、 6.4															
Inherent flow characteristics		Straight \Equal percentage															
Inherent adjustable ratio R		50:1															
Allowable leakage	Single seat	Hard seal: VI-class, Soft seal:VI															
	Sleeve	Hard seal: VI-class, Soft seal:VI															
Operating temperature(°C)		-20-220、 -40-250、 -40-450、 -60-450															
Signal range(DC)		0-10mA 4-20mA 1-5V 0-10V															
Power supply voltage		220V 50HZ															
Mode of action		Electric open, electric close															
Valve status when signal fails		Fully open, fully closed, hold position															
Valve seat diameter		10	12	15	20												

The performance indicators of this product are in accordance with GB/T4213

ECV- V VI VII VIII -S2381 Electronic Electric Sleeve Regulating Valve

Flow characteristics diagram

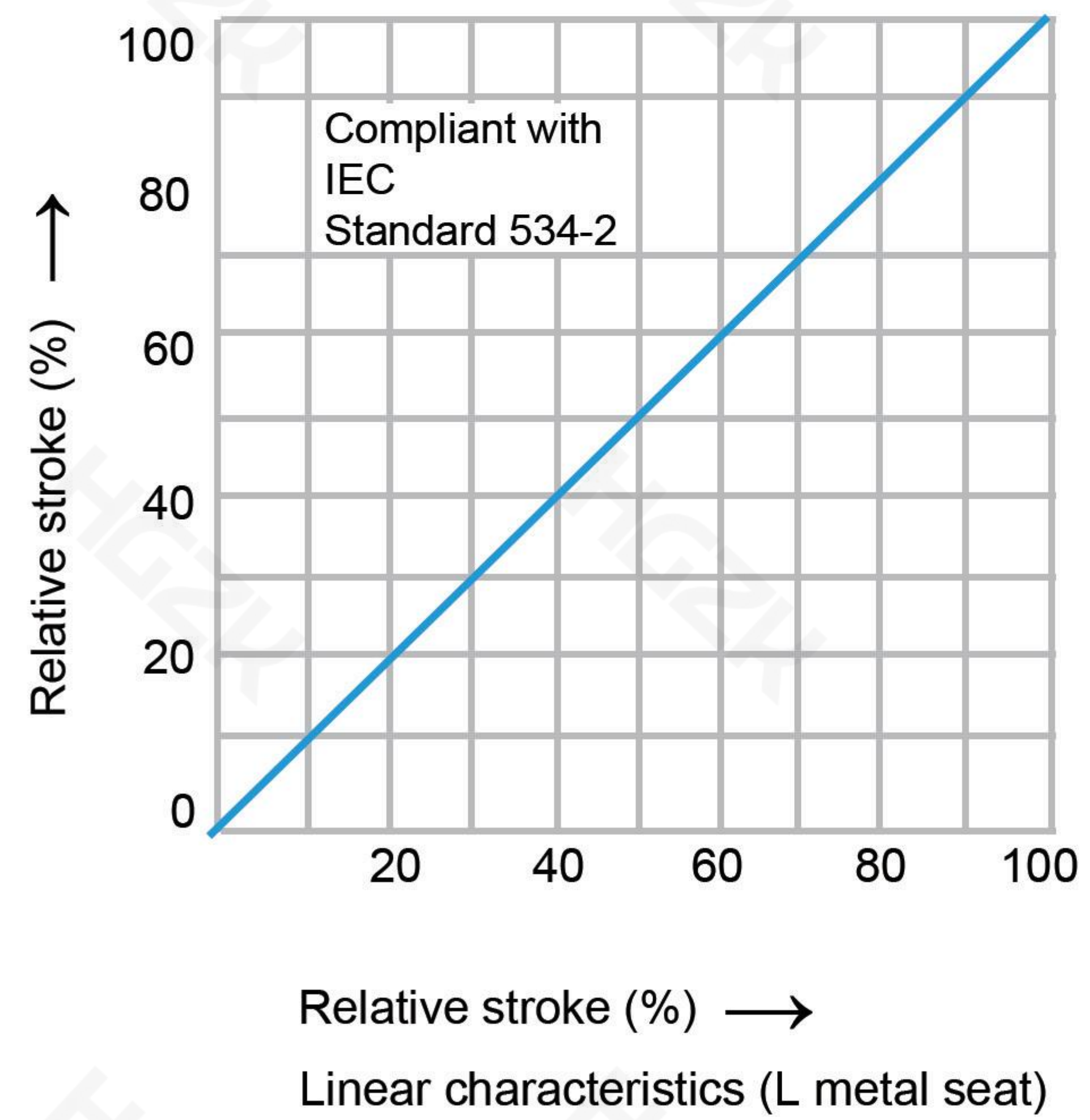
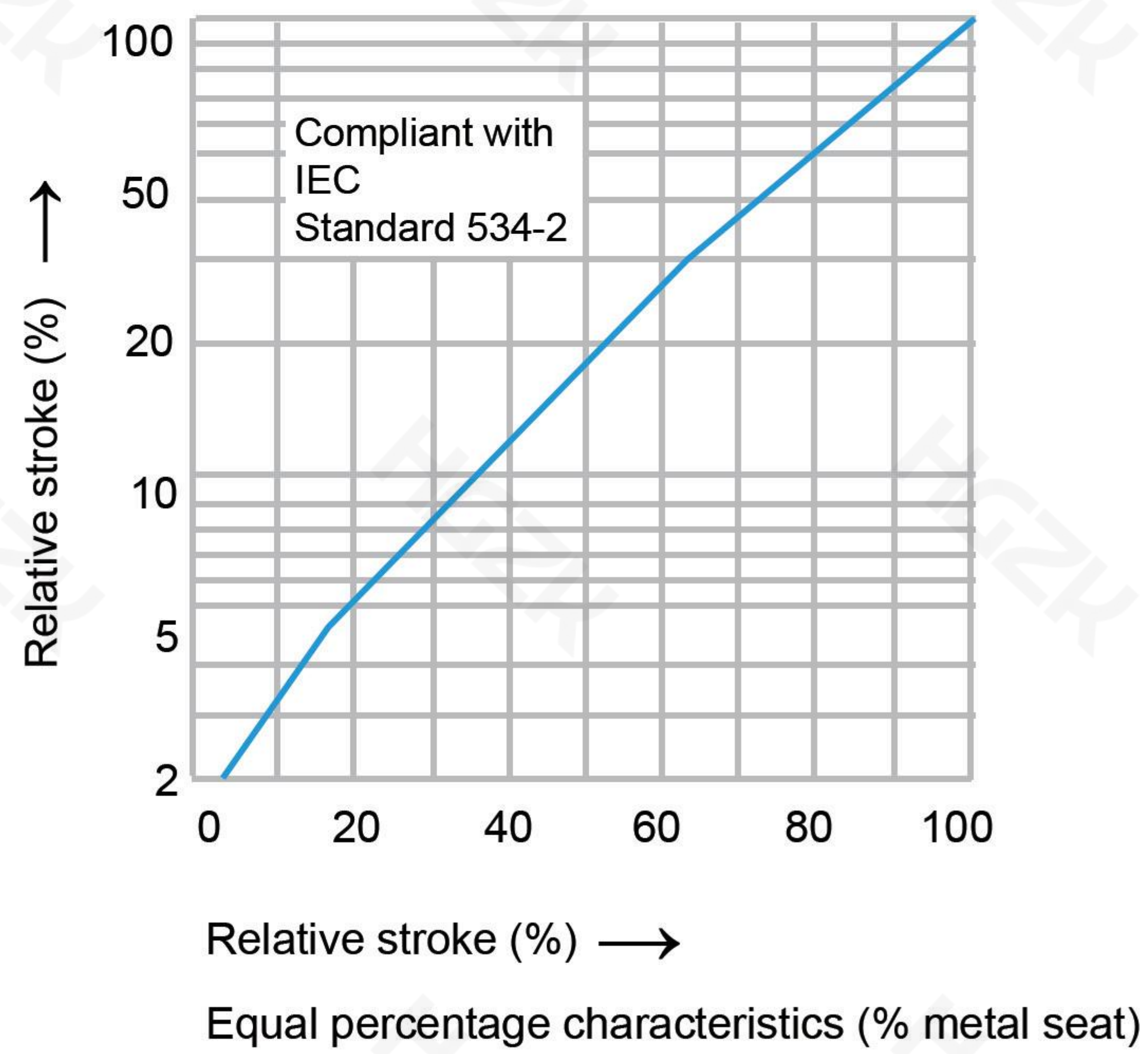

Dimensions

mm

DN (mm)	L			H Normal	Flange standard is according to JB79-1994 PN1.6MPa					
	PN16	PN40	PN64		D	D1	D2	b	I1	N - Φ
DN25	184	197	210	420	115	85	65	14	2	4-14
DN32	200	205	215	480	135	100	78	16	2	4-18
DN40	222	235	251	600	145	110	85	16	3	4-18
DN50	254	267	286	670	160	125	100	16	3	4-18
DN65	276	292	311	830	180	145	120	18	3	4-18
DN80	298	317	337	835	195	160	135	20	3	8-18
DN100	352	368	394	860	215	180	155	20	3	8-18
DN150	451	473	508	1065	280	240	210	24	3	8-23
DN200	600	620	650	1110	335	295	265	26	3	12-23
DN250	650	680	703	1225	405	355	320	30	3	12-25
DN300	740	760	772	1285	460	410	375	30	4	12-25
DN350	845	900		1375	520	470	435	34	4	16-25

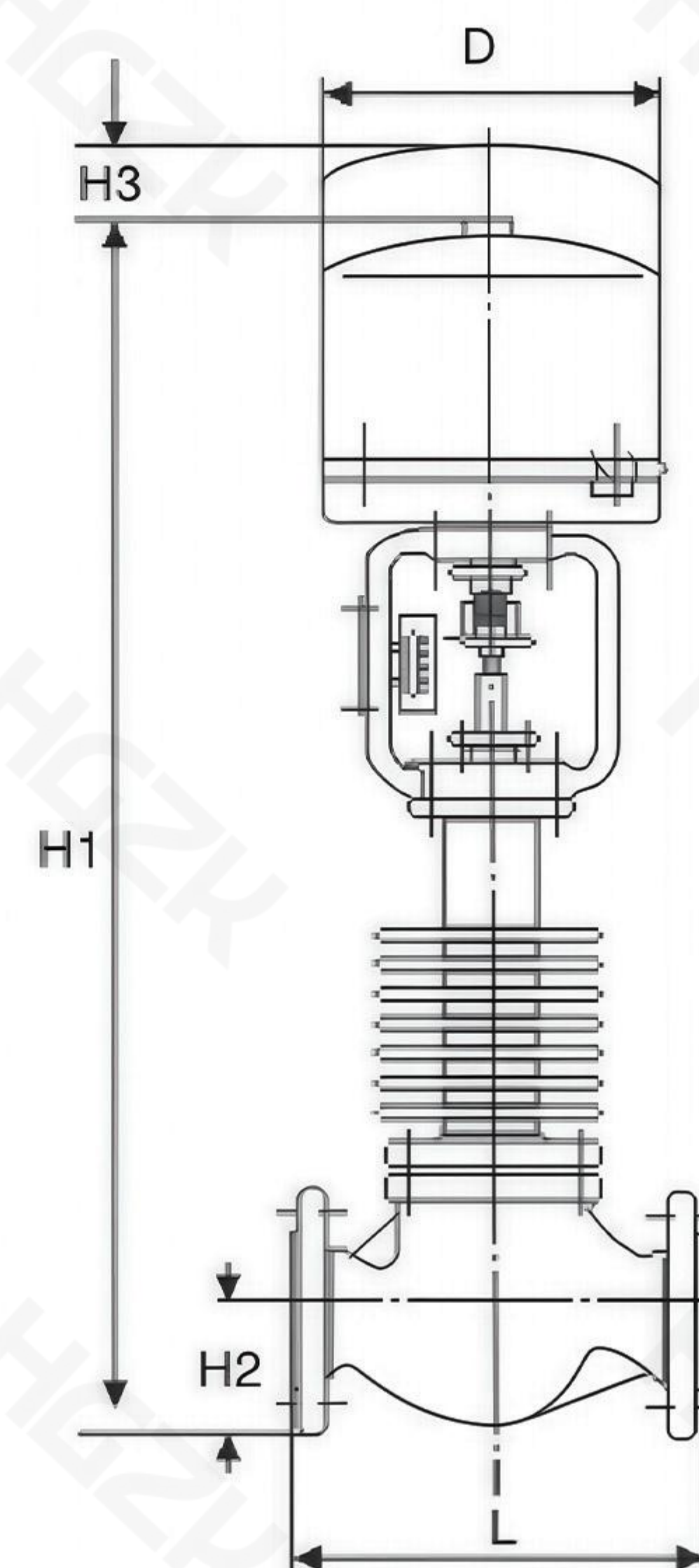
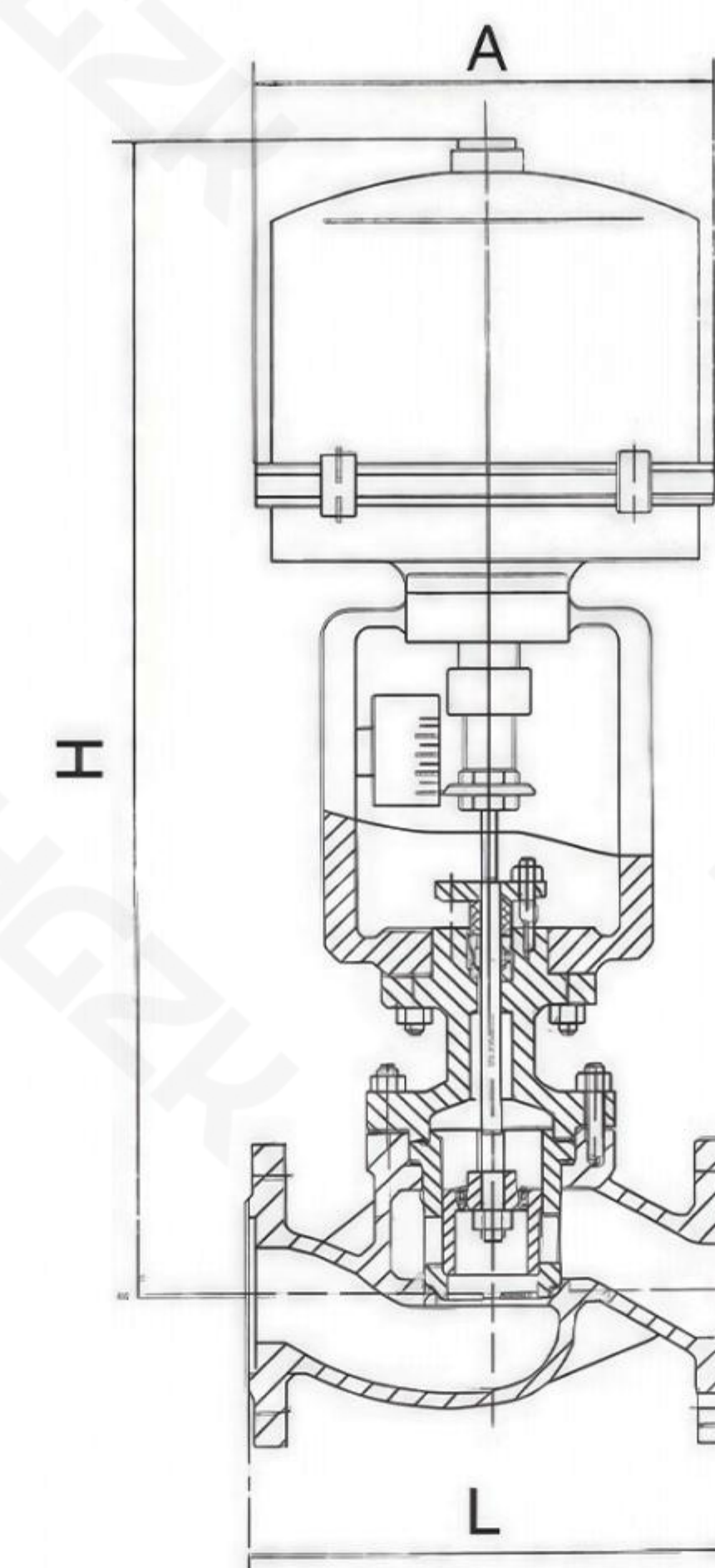

E3CV-VVIVIIVIII-SFL/HL381 Electronic Electric Three-way Control Valves

Overview

The E3CV-VVIVIIVIII-SFL/HL381 electronic electric three-way control valves consist of a 3810L series electronic electric actuator and a three-way valve control mechanism. The electric actuator incorporates a servo system, eliminating the need for a separate servo amplifier. Operation is controlled with only an input signal and power supply, simplifying wiring. The control mechanism operates in both converging and diverting modes, and in some applications, can replace two two-way valves and a three-way connection. It is commonly used for two-phase regulation in heat exchangers and simple ratio control.



Main technical parameters of the regulating mechanism

Nominal diameter (mm)	Confluence	25	32	40	50	65	80	100	125	150	200	250	300
	Diversion						80	100	125	150	200	250	300
Valve seat diameter(mm)		26	8	40	50	66	80	100	125	150	200	250	300
Rated flow coefficient (Kv)	Confluence	8.5	13	21	34	53	85	135	210	340	535	800	1260
	Diversion												
Rated stroke(mm)		1.6 ,4.0 ,6.4											
Hard seal temperature °C		16		25		40		60		100			
Actuator Model		381LSA-20 381LXA-20		381LSB-30 381LXB-30		381LSB-50 381LXB-50		381LSC-65			381LSC-99		
Flow characteristics		Straight line											
Adjustable ratio		30 : 1											
Flange size		Cast iron flanges comply with JB78-59, cast steel flanges comply with JB79-59.											
Flange type		Flange sealing surface conforms to JB77-59.											
Valve body material		WCB (ZG230-450), ZG1Cr18Ni9Ti											

Main technical parameters of actuator

Model	Rated output force N	Speed mm/sec	Technical parameters
381LSA-08	800	4.2	Power supply: AC220V 50Hz Input signal: DC4-20mA DC1-5V (shielded signal line) Output opening signal: DC4-20mA Enclosure rating: IP55 equivalent Explosion-proof mark: Exd II BT4
381LSA-20	2000	2.1	
381LSB-30	3000	3.5	
381LSB-50	5000	1.7	
381LSC-65	6500	3.4	
381LSC-99	10000	2.0	
381LXA-08	800	4.2	
381LXA-20	2000	2.1	
381LXB-30	3000	3.5	
381LXB-50	5000	1.7	

E3CV-VVIVIIVIII -SFL/HL381 Electronic Electric Three-way Regulating Valve

Performance indicators

Model		Index value	
Basic error %		± 2.5	
Hysteresis %		2.5	
Dead zone %		1.0	
Deviation of starting and ending points %	Fail-Safe Open	Start	± 2.5
		End	± 2.5
	Fail-Safe Close	Start	± 2.5
		End	± 2.5
Rated stroke deviation %		2.5	
Allowable leakage L/h		1×10 rated capacity of the valve	

Allowable pressure difference

Nominal diameter mm	25	32	40	50	65	80	100	125	150	200	250	300
Allowable pressure difference Mpa	0.32	2.20	2.20	1.41	1.38	0.94	0.61	0.51	0.36	0.20	0.19	0.13

Dimensions of three-way confluence regulating valve

DN (mm)	L			Stroke	D	Hi			H		
	PN(MPa)					PN(MPa)			Normal Temp	Medium Temp	
	1.6	4.0	6.4			1.6	4.0	6.4			
25	185	190	200	16	225	145	150	160	555	707	
32	200	210	210			150	160	170	561	709	
40	220	230	235	25		160	170	180	660	812	
50	250	255	265			180	190	200	675	827	
65	275	285	295	40	255	210	220	220	863	1027	
80	300	310	320			220	230	240	868	1032	
100	350	355	370			25	245	250	260	872	1036
125	410	425	440				295	300	300	905	1120
150	450	460	475	60		310	320	320	920	1135	
200	550	560	570			370	380	380	950	1165	
250	640	660	670	100		415	465	474	474	1203	1440
300	740	760	770				580	585	585	1265	1502

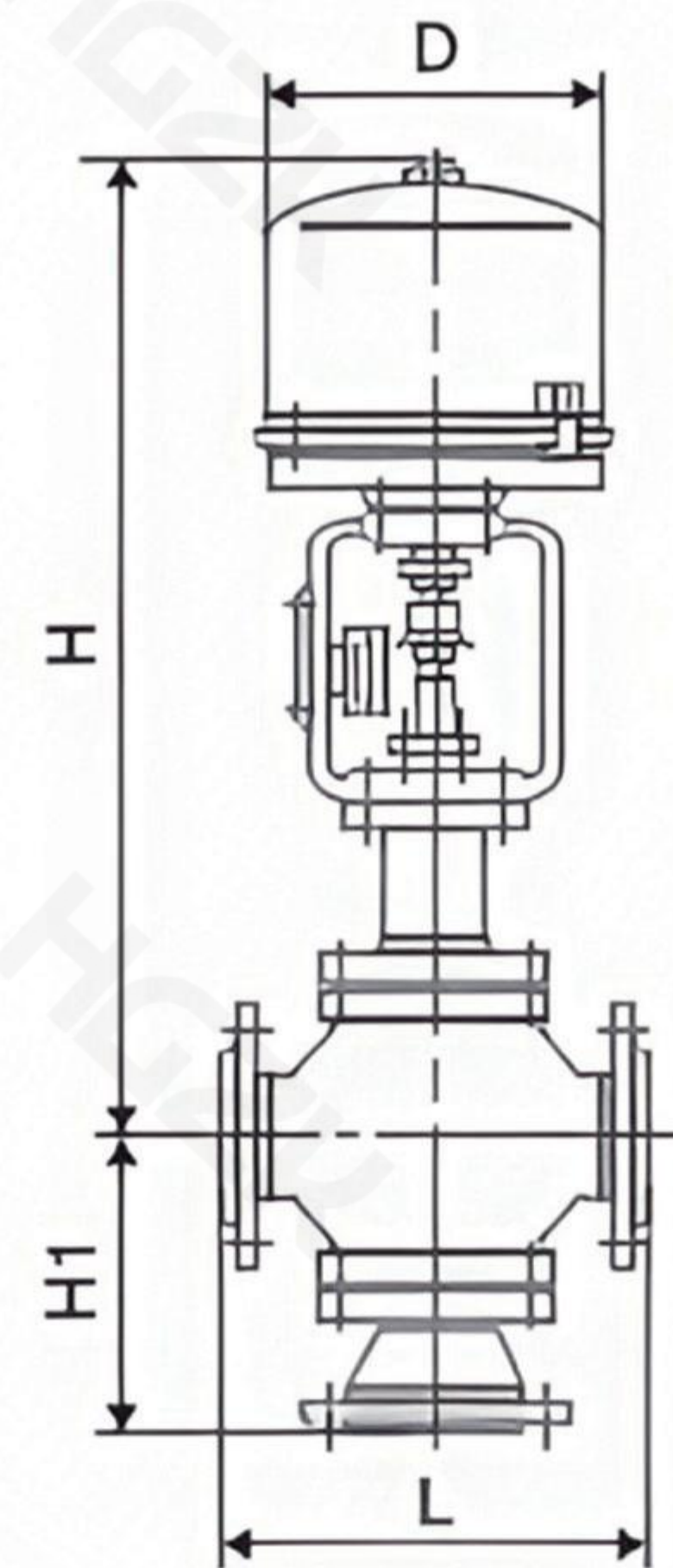

Normal temperature type

Three-way diverter regulating valve dimensions

DN (mm)	L			Stroke	D	Hi			H	Weight Kg	
	PN(MPa)					PN(MPa)				PN(MPa)	
	1.6	4.0	6.4			1.6	4.0	6.4		4.0	6.4
80	300	310	320	40	255	240	250	260	885	78	98
100	350	355	370	40	255	265	275	285	897	93	118
125	410	425	440	60	255	310	320	320	931	155.5	172.5
150	450	460	475	60	255	330	340	340	945	207.5	323.5
200	550	560	570	60	255	390	400	400	979	384.5	412.5
250	640	660	670	100	415	530	540	540	1268	627	659
300	740	760	770	100	415	605	612	612	1294	780	819

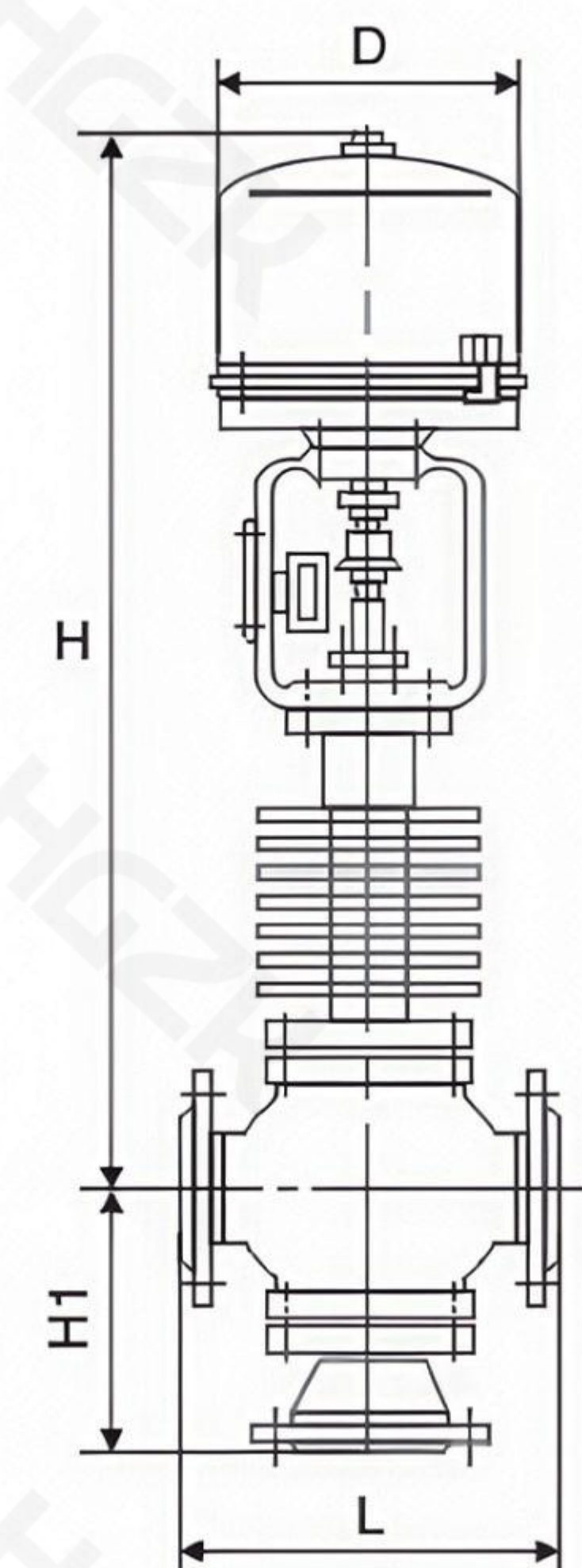

Medium temperature type

Allowable pressure difference

When ordering, please specify the following:

1. Product model
2. Nominal diameter
3. Valve body material
4. Pressure across the valve
5. Media type and temperature range
6. Whether the electric actuator includes a space heater
7. Whether the electric actuator includes an overload protection device
8. Any other special requirements

PDV-VVIVIIVIII Electronic Electric Regulating Butterfly Valve

Overview

The PDV-VVIVIIVIII electronic electric regulating butterfly valve consists of a 381L electronic electric actuator and a butterfly valve regulating mechanism. The actuator incorporates a servo system, eliminating the need for a separate servo amplifier. It features a simple structure high flow capacity, and high regulating precision. It is suitable for regulating and controlling fluids containing suspended particles, as well as thick, turbid, and slurry fluids. It is widely used in industrial production processes in the chemical, petroleum, metallurgical, and power plants.



Feature

Category	Linear		Angular travel	
	Normal temperature type	Medium temperature type	Normal temperature type	Medium temperature type
Model	ZDRW-6 $\frac{8}{K}$	ZDRW-6 $\frac{8}{K}$ G	ZDRW-6 $\frac{8}{K}$	ZDRW-6 $\frac{8}{K}$ G
Specification	DN600-1000		DN50-500	

Main technical parameters of butterfly valve regulating mechanism

Nominal diameter (mm)	50	80	100	125	150	200	250	300	350	400	450	500	600	700	800	900	1000
Nominal pressure (MPa)	0.6																
Medium temperature °C	Normal temperature: -20-200°C (cast iron); -40-250°C (cast steel) Medium temperature -40~450°C (cast stainless steel)																
Corner range °	0~70																
Flow characteristics	Approximately equal percentage																
Ambient temperature °C	Without space heater: -10~60; With space heater: -35~60																
Take-over flange	According to JB78-59 clamped flange connection																
Valve body material	HT200; 35; 2G230-450; 1Cr18Ni9; ZG1Cr18Ni9Ti																
Valve plate material	HT200; 35; 2G230-450; 1Cr18Ni9; ZG1Cr18Ni9Ti																

3810L linear electronic electric actuator technical parameters

Model	Output force N	Speed mm/s	Maximum stroke mm	Signal pressure(KPa)
381LSC-99	10000	2.0	100	Power supply: AC 220V, 50Hz Control signal: 1-5V DC, 4-20mA DC (Shielded signal cable) Opening signal: 4-20mA DC Protection rating: IP55 equivalent Explosion-proof mark: ExdIIBT4

Self-operated Pressure Regulating Valve

Overview

The ZZYP self-operated pressure regulating valve is an actuator that requires no external energy, utilizing the energy of the regulated medium to achieve automatic regulation. Its key feature is its ability to operate in locations without electricity or gas, while also conserving energy.

The pressure setpoint can be adjusted freely during operation. Its quick-opening flow characteristic, sensitive operation, and excellent sealing performance make it widely used in various industrial applications, including petroleum, chemical, electric power, metallurgy, food, textile, machinery manufacturing, and residential buildings, for automatic control of pressure reduction and stabilization (for post-valve regulation) or pressure relief and pressure holding (for pre-valve regulation) for various gases, liquids, and steam media. The included condenser allows operation at temperatures $\leq 350^{\circ}\text{C}$.



Main technical parameters and performance indicators

Nominal diameter(mm)	20	25	32	40	50	65	80	100	125	150	200	250	300
Rated flow coefficient	7	11	20	30	48	75	120	190	300	480	760	1100	1750
Sleeve	8		10		14	20		25	40		50	60	70
Single seat	1.6、4.0、6.4												
Rated stroke(mm)	15~50 40~80 60~100 80~140 120~180 160~220 200~260 240~300 280~350 330~400 380~450 430~500 480~560 540~620 600~700 680~800 780~900 880~1000 600~1500 1000~2500												
Hard seal temperature $^{\circ}\text{C}$	Open quickly												
Diaphragm effective area(cm^2)	± 5												
Nominal Pressure(MPa)	Hot water, steam, various gases and low viscosity media												
Operating temperature $^{\circ}\text{C}$	≤ 80						≤ 350						
Allowable leakage	Hard seal (l/h)	Single-seat: $\leq 10^{-4}$ valve rated capacity (Class IV) Double-seat, sleeve: $\leq 5 \times 10^{-3}$ valve rated capacity (Class II)											
	Soft seal (ml/h)	0.15	0.30	0.45	0.60	0.90	1.7	4.0	6.75	11.10	11.60		
Decompression ratio	Max	10											
	Min	1.25											

Self-operated Pressure Regulating Valve

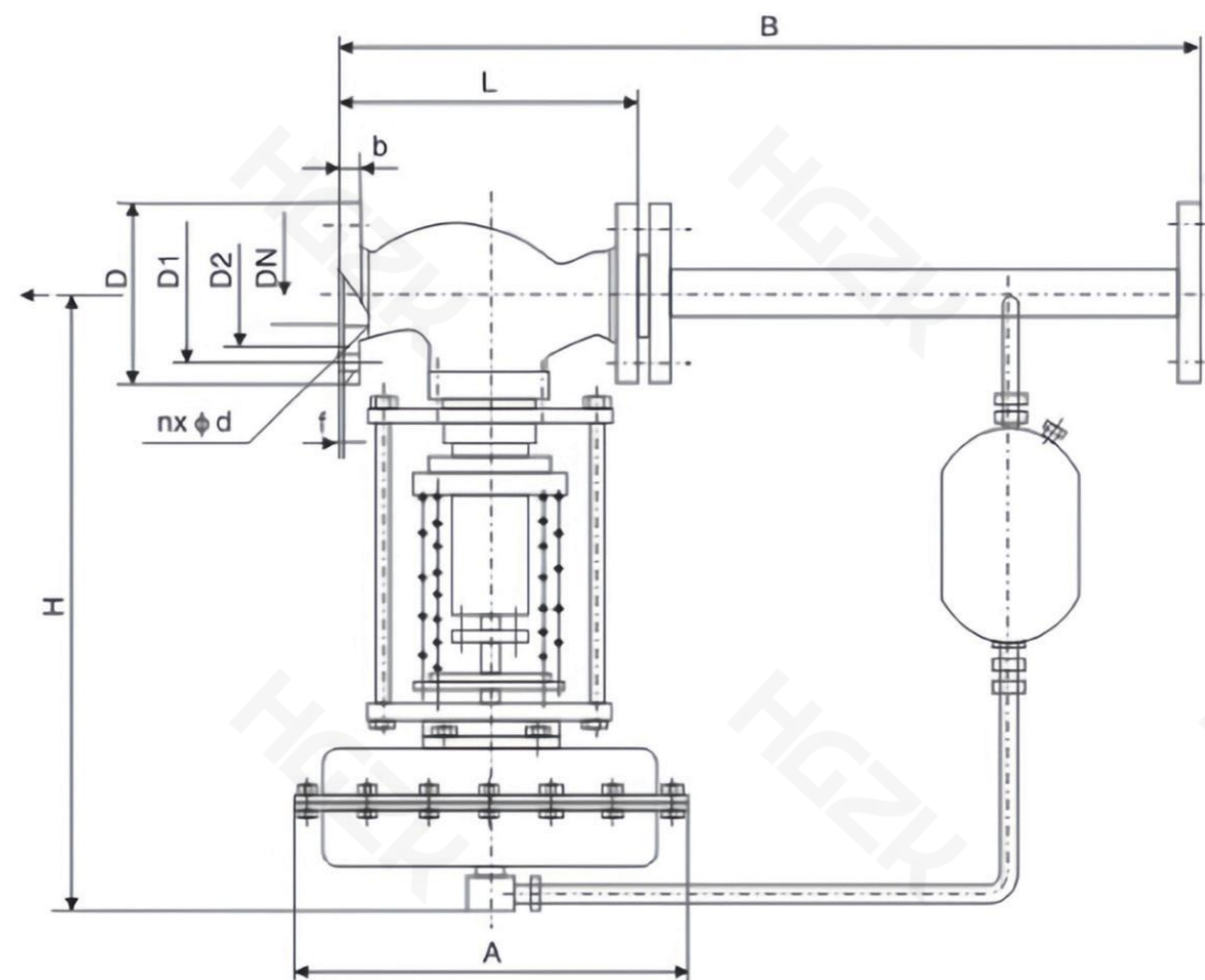

Dimensions and weight

DN(mm)	20	25	32	40	50	65	80	100	125	150	200	250	300	
Flange connection size B	383		512		603	862		1023	1380		1800	2000	2200	
Flange end distance L	181	184	200	222	254	276	298	352	410	451	600	650	740	
Pressure adjustment range Kpa	15~140	H	475	520		540	710		780	840	880	915	940	1000
		A	280	380										
	130~300	H	455	500		520	690		760	800	870	880	900	950
		A	230											
	280~500	H	450	490		510	680		750	790	860	870	890	940
		A	176		194		280							
	480~1000	H	445	480		670		740	780	850	860	880	930	
		A	176		194		280							
	600~1500	H	445	570		600	820		890	950		1000	1100	1200
		A	85											
	1000~2500	H	445	570		600	820		890	950		1000	1100	1200
		A	85											
Weight kg	26		37		42	72	90	114	130	144	180	200	250	
Pressure pipe joint thread	M16 × 1.5													

Main parts materials

Part Name	Material
Valve body	WCB、ZG1Cr18Ni9Ti、ZGCr18Ni12Mo2Ti
Valve core	1Cr18Ni9Ti、Cr18Ni12Mo2Ti
Valve seat	1Cr18Ni9Ti、Cr18Ni12Mo2Ti
Valve stem	1Cr18Ni9Ti、Cr18Ni12Mo2Ti
Rubber diaphragm	Nitrile, Ethylene propylene, fluorine, oil-resistant rubber
Rubber diaphragm	A3, A4 steel coated with PTFE
Filler	Polytetrafluoroethylene, flexible graphite

Ordering Instructions

- Product Model
- Nominal Diameter
- Nominal Pressure
- Rated Flow Coefficient (KV)
- Valve Inlet Pressure
- Valve Outlet Pressure
- Valve Body and Valve Plug Material
- Operating Medium
- Medium Temperature
- Control Method

V230/231 Self-operated Pressure Regulating Valve

Overview

This direct-acting, self-operated pressure (differential pressure) regulating valve, consisting of a valve body, valve seat, and valve core, is an energy-saving product that automatically adjusts pressure based on the pressure changes of the medium being regulated, without requiring external energy. It can be used as a pressure control device for non-corrosive media (maximum temperature 350°C), such as liquids, gases, and steam.

It is widely used in industries such as petroleum, chemical, metallurgy, and light industry, as well as in urban heating systems.

This product complies with GB/T4213-1992.



Feature

Category	Pressure control regulating valve				Differential pressure control valve			
	After-valve pressure regulating valve		Valve front pressure regulating valve		Differential pressure rising valve closed		Differential pressure rising valve opens	
	Hard seal	Soft seal	Hard seal	Soft seal	Hard seal	Soft seal	Hard seal	Soft seal
Model	V230 D01	V231 D01	V230 D02	V231 D02	V230 D03	V231 D03	V230 D04	V231 D04
Specifications	DN15~250							

Main technical parameters

Nominal diameter mm	15	20	25	32	40	50	65	80	100	125	150	200	250	
Rated flow coefficient Kv	3.2	5	8	12.5	20	32	50	80	125	160	320	450	630	
Rated stroke(mm)	1.6 / 4.0													
Z value	0.6	0.6	0.6	0.55	0.55	0.5	0.5	0.45	0.4	0.35	0.3	0.2	0.2	
Maximum operating temperature °C	V230 V231	Liquid <140; Gas <80												
	Hard seal V230	With isolation tank ≤ 200										Equipped with isolation tank and extension piece ≤300*		
		With isolation tank and heat sink ≤ 200												
Pressure balancing element	Bellows										Rolling diaphragm			
Flange standard	DIA (flange standards available upon request)													
Valve body material	PN16: Cast iron (operating temperature ≤ 200°C); PN40: Cast steel, cast stainless steel (operating temperature ≤ 350°C)													
Valve core material	Stainless steel; soft seal is stainless steel with an embedded rubber ring.													
Maximum working pressure MPa	Nominal pressure (note the relationship between ΔP_{max} and operating pressure and operating temperature)													

Note: 1. For liquids > 140°C and gases > 80°C, install the valve in reverse.
2. Z value: Noise coefficient, used to measure noise level.
For detailed calculations, see the Self-operated Regulating Valve Selection Guide.

ZZDQ Nitrogen Sealing Device

Features and uses

The ZZDQ ammonia seal device is a self-operated micro-pressure control system independently developed and manufactured by our factory. It is primarily used to maintain a constant pressure of the protective gas (typically nitrogen) at the top of the container, preventing direct contact between the material inside the container and air, thereby preventing volatilization and oxidation, and ensuring container safety. It is particularly suitable for gas seal protection systems for various large storage tanks. This product features energy saving, sensitive operation, reliable operation, and easy operation and maintenance. It is widely used in the petroleum, chemical and other industries.

Feature

1. Requires no external power source and can operate in environments without electricity or gas, providing convenience, energy savings, and cost reduction.
2. The nitrogen supply and release pressures of the helium sealing device are easily set, enabling continuous production.
3. The pressure sensing diaphragm features a large effective area and a low spring stiffness, ensuring sensitive operation and stable device operation.
4. The packingless design reduces valve stem friction, resulting in rapid response and high control accuracy.
5. The nitrogen supply device is pilot-operated, achieving a pressure reduction ratio of up to 100:1, providing excellent pressure reduction and high control accuracy.
6. To ensure the safety of the storage tank, a breather valve is required on the tank top.
7. The breather valve serves only as a safety feature, avoiding the frequent opening and closing defects of conventional nitrogen sealing devices that can easily damage the device.

Structure and Working Principle

Working Principle of a Nitrogen Blanketing System

The nitrogen blanketing system consists of a nitrogen supply unit and a nitrogen purge unit.

The nitrogen supply unit consists of a pilot and a main valve.

The nitrogen purge unit is composed of a pressure-to-open micro-pressure regulating valve with internal feedback.

The nitrogen blanketing pressure is generally set at 100 mmH₂O (millimeters of water column) and is precisely controlled by this device.

When the tank is filling with liquid: the inlet valve opens, material is added to the tank. The rising liquid level causes the gas phase volume to decrease, increasing the pressure. When the tank pressure rises above the set pressure of the nitrogen purge unit, the nitrogen purge valve opens, releasing nitrogen to the atmosphere, reducing the tank pressure.

When the pressure drops to the set pressure of the nitrogen purge unit, the nitrogen purge valve automatically closes.

When the tank is discharging liquid: the outlet valve opens, material is discharged, and the falling liquid level causes the gas phase volume to increase, reducing the tank pressure. At this point, the nitrogen supply unit opens, injecting nitrogen into the tank, raising the tank pressure to maintain the set pressure.

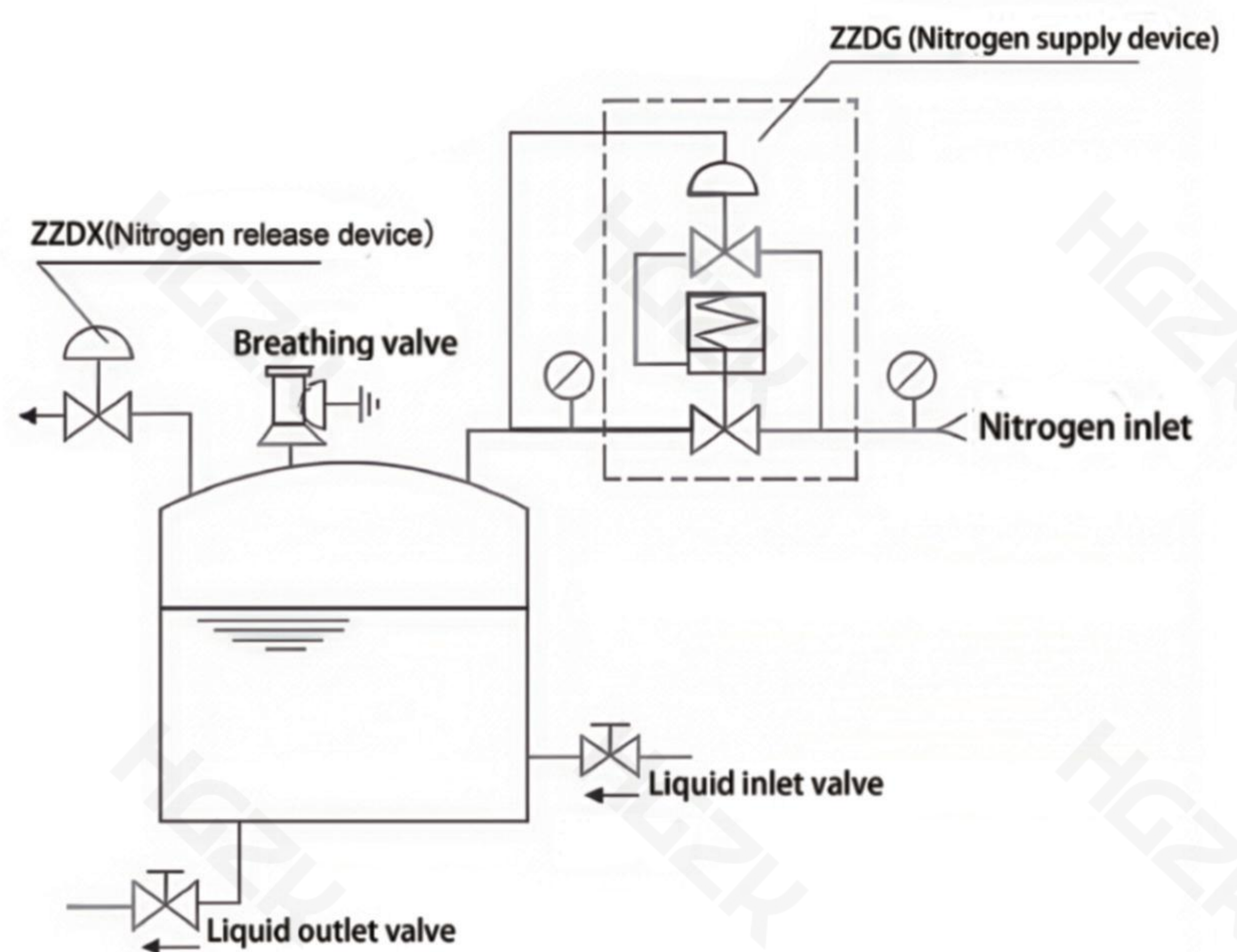

ZZDQ Type Nitrogen Sealing Device

Working Principle of Nitrogen Supply Device

The ammonia supply device structure (see Figure 4) introduces the medium from the pressure point located at the top of the tank into the detection mechanism (7) through the pressure guide pipe. The medium generates a force on the detection element that is balanced by the spring (8) and the preload force. When the pressure in the tank drops below the pressure setting point of the nitrogen supply device, the balance is broken, causing the pilot valve core (6) to open, allowing the gas in front of the valve to pass through the pressure reducing valve (5) and the throttle valve (4) and enter the upper and lower membrane chambers of the main valve actuator (3), opening the main valve valve core (2) and filling the tank with nitrogen. When the pressure in the tank rises to the pressure setting point of the nitrogen supply device, the preset spring force closes the pilot valve core (6), and due to the action of the spring in the main valve actuator, the main valve closes, stopping the nitrogen supply.

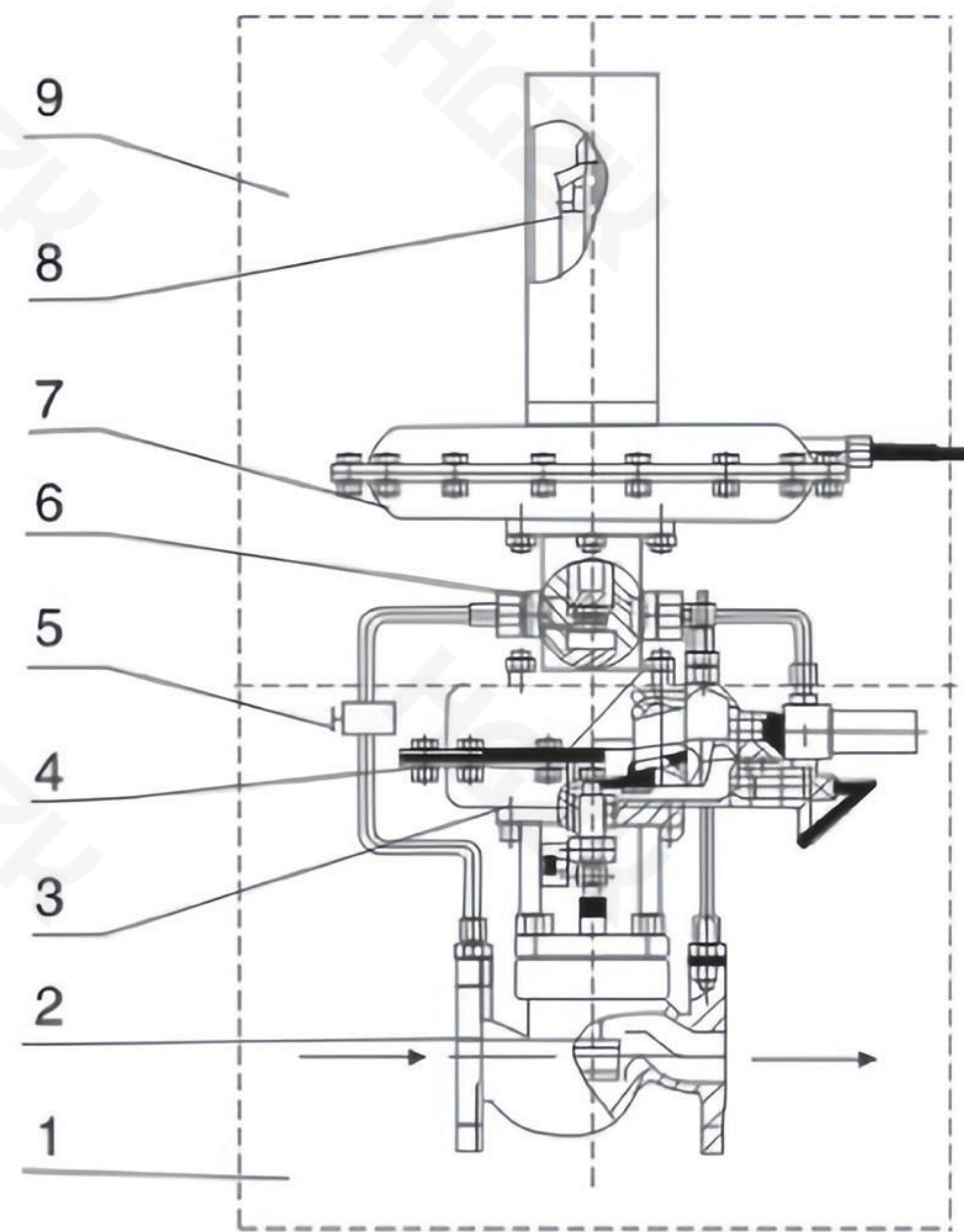

1. Main valve 2. Main valve spool 3. Main valve actuator
4. Throttle valve 5. Pressure reducing valve 6. Pilot spool
7. Detection mechanism 8. Preset spring 9. Pilot

Fig .4

Structural principle diagram of nitrogen supply device

Working Principle of the Nitrogen Release Device

The ammonia release device structure (see Figure 5) uses an internal feedback structure. The medium enters the detection mechanism (2) directly through the valve cover. The medium exerts a force on the detection element that balances the preload force of the preset spring (3). When the pressure in the tank rises above the pressure set point of the nitrogen release device, the balance is broken, causing the valve core (1) to move upward, opening the valve and releasing nitrogen to the outside. When the pressure in the tank drops to the pressure set point of the nitrogen release device, the valve closes due to the action of the preset spring force.

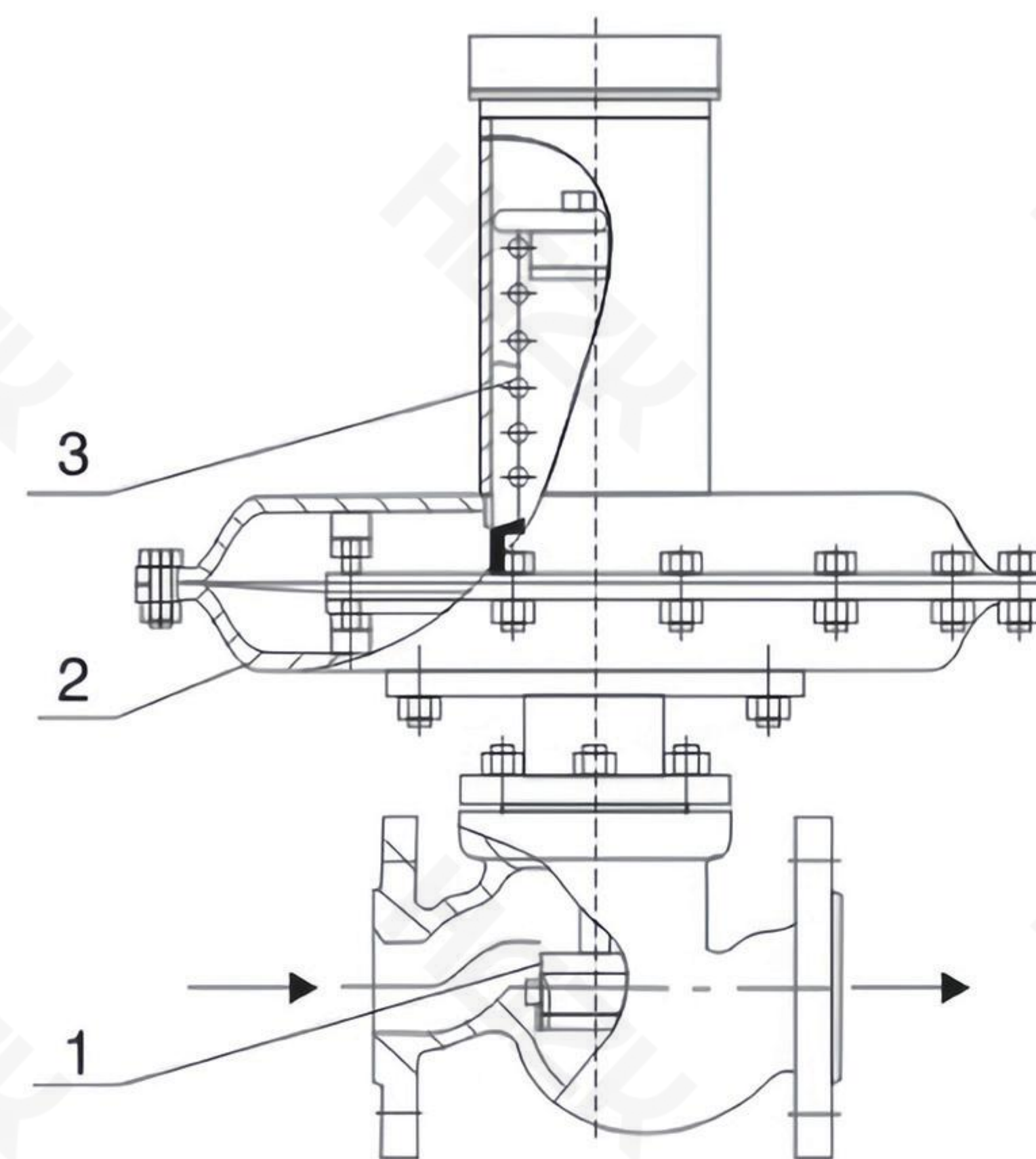

1.Main valve 2.Detection mechanism 3.spring

Fig .5

Structural principle diagram of nitrogen release device

Description

- 1.The typical nitrogen supply pressure is between 3×10^5 and 10×10^5 Pa.
- 2.The tank top breather valve serves only as a safety measure, acting in the event of a main valve failure, causing the tank pressure to over- or under-pressure. It does not operate under normal circumstances.
- 3.The nitrogen release valve is installed on the tank top. Its diameter is generally the same as that of the escape valve.
- 4.The pressure set point of the nitrogen release valve is generally slightly higher than that of the nitrogen supply valve to prevent frequent operation of the ammonia supply and release system, which wastes ammonia and shortens the equipment's service life.
- 5.If your operating conditions differ from those in the selection manual, please contact our Technical Development Department for a resolution.

ZZWEP Self-operated Electric Temperature Regulating Valve

Uses and features

The self-operated electro-thermal regulating valve is designed for large-diameter pipelines and thermal oil applications. It operates on 220V power and uses the medium's own energy to automatically regulate the temperature of steam, hot water, thermal oil, and other gases. Suitable for overheat prevention and heat exchange, it offers a simple structure, user-friendly operation, broad temperature range, rapid response, and reliable sealing. Its continuous adjustment capability makes it ideal for hot water supply in chemical, petroleum, food, textile, and hospitality sectors.

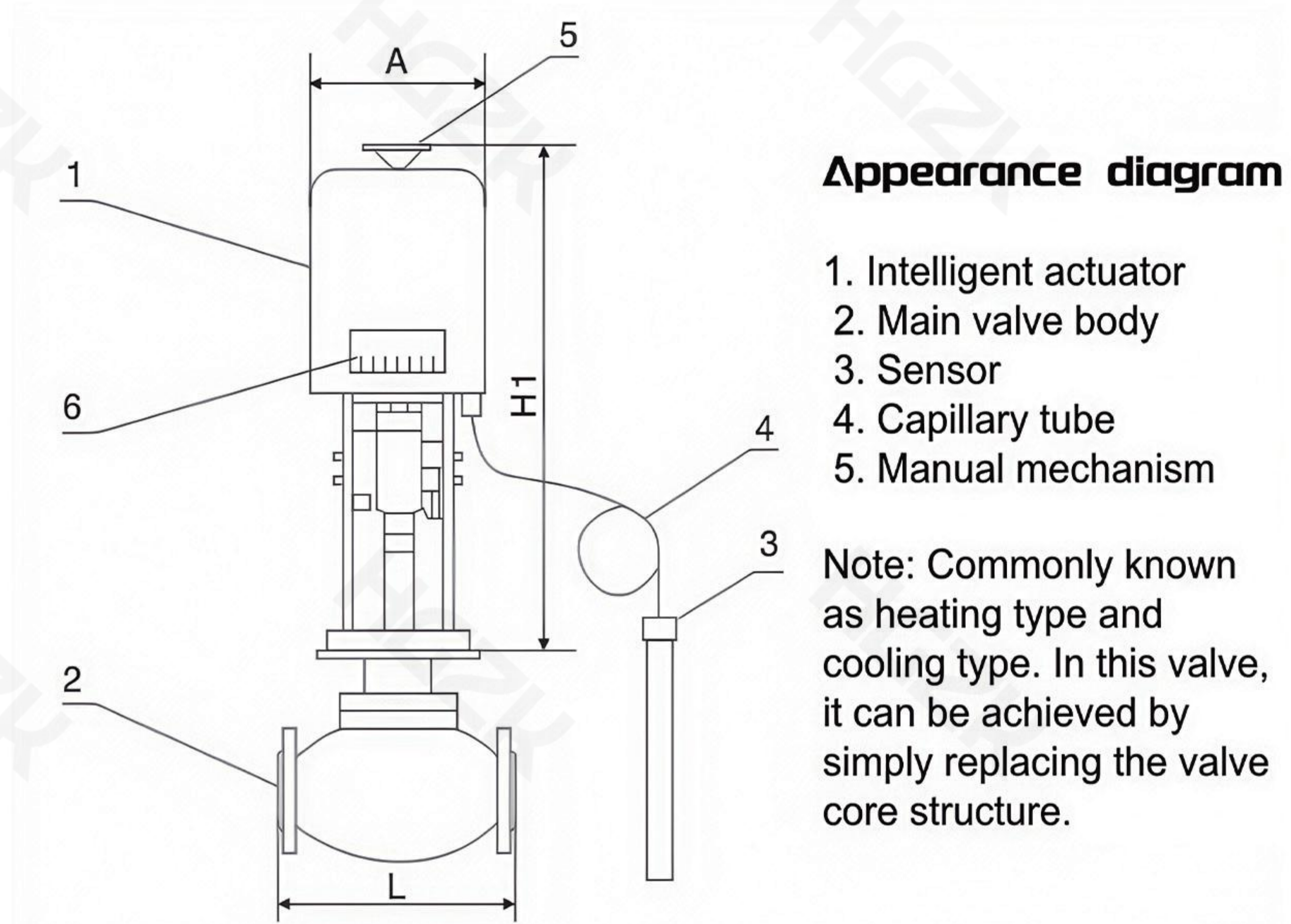

Structure and principle

The control valve comprises a main valve, an intelligent actuator, and a sensor, and is available in both heating and cooling versions to suit user requirements.

As shown in the attached diagram, the heating control valve operates as follows: Initially, the main valve is half-open and the sensor is neutral. Upon power-on, the valve opens fully, allowing the medium to flow through in the direction of the arrow, thereby heating the thermal storage tank. Once the temperature reaches the set value, the sensor sends a linear signal to the intelligent actuator, which drives the valve stem to close the valve and stop heating. When the temperature drops below the set point, the sensor signals the actuator to gradually reopen the valve. The medium flows into the tank along a parabolic curve, reheating it to the target temperature and maintaining stable thermal control.

Main technical parameters

Nominal Diameter (DN) (mm)	15	20	25	32	40	50	65	80	100	125	150	200
Nominal Pressure (PN) (MPa)	1.6 4.0											
Flow Capacity (m ³ /h)	5	7	10	16	25	40	63	100	160	250	410	630
Rated Stroke (mm)	6		8	10	14			20		30	30	40
Temperature Adjustment Range (°C)	0-120 100-250											
Adjustment Accuracy (%)	± 1 ~ ± 5											
Used Medium	Steam, water, oil, gas											
Allowable Leakage	Hard Seal	10 ⁻⁴ × valve rated capacity										
	Soft Seal	"0"										
Capillary Tube Length (m)	3m 5m 10m											
Bubble Insertion Depth	270 430 630											
Connecting Thread	3/4 "1"											

ZZWP Self-operated temperature regulating valve

Application

The ZZWP self-operated temperature regulating valve, consisting primarily of a control valve and a thermostat, is an energy-saving product that automatically adjusts temperature based on the temperature of the controlled medium itself, without requiring external energy. It is primarily suitable for automatic temperature control in heat exchangers for media such as hot and cold water, steam, and oil, and is widely used in urban heating systems and other industrial fields. It is available in nominal pressures of PN 16 and PN 40, nominal diameters of 15 to 200 mm, and a temperature adjustment range of 0 to 270°C.

Main parts materials

Valve body	WCB cast steel
Valve seat	1Cr18Ni9
Valve core	1Cr18Ni9
Bells sleeve	1Cr18Ni9
Balance bellows	1Cr18Ni9
Temperature package	H62, 1Cr18Ni9
Capillary	H62, 1Cr18Ni9
Connector	35, 1Cr18Ni9



Main technical parameters

Nominal diameter(mm)	15	20	25	32	40	50	65	80	100	125	150	200	
Nominal Pressure (MPa)	1.6 4.0												
Rated flow coefficient (Kv)	Single Seat	5	7	11	20	30	48	75	120	190	300	480	760
	Double Seat			12	22	33	53	83	132	209	330	528	836
	Sleeve			11	20	30	48	75	120	190	300	480	760
Rated Stroke (mm)	6			8	10	14			20			35	
Maximum Allowable Pressure Differential (MPa)	1.6						1.5			0.5			
Temperature Adjustment Range	0~70 °C、50~120 °C、100~170 °C、150~220 °C、200~270 °C												
Adjustment Accuracy (%)	± 5												
Allowable Overload Value (°C)	The upper limit of the temperature control valve range is added by 50°C												
Ambient Operating Temperature	-40 ~ 80 °C												
Mounting Connector	G1"												
Capillary Length (m)	3 \ 5 \ 8												
Allowable leakage	Hard Seal (L/h)	Single seat: $\leq 10^{-4}$ x valve independent capacity (IV level) Double seat and sleeve: $\leq 5 \times 10^{-3}$ valve independent capacity (II level)											
	Soft Seal (mL/min)	0.15	0.30	0.45	0.60	0.90	1.70	4.0	6.75	11.10	16.0		

Calculation of Regulating Valve Diameter

Using the control valve's flow coefficient (Cv) can simplify valve sizing. The Cv flow coefficient is defined as the number of US gallons per minute of fresh water at 60°F (15.6°C) flowing through the valve when the valve is fully open and the pressure differential is 1 psi (0.07 kgf/cm²).

To determine the sizing of a control valve, first calculate the required Cv based on known fluid conditions. Then, select the appropriate control valve sizing from the Cv table in the Product Technical Data Sheet.

Main parts materials

The ratio of the pressure difference across the control valve to the total system pressure drop (Pr) is a metric used to evaluate the performance of a control valve. If the flow rate fluctuates significantly, the Pr value should be larger. Similarly, if the fluctuation is smaller, the Pr value should be smaller. Generally speaking, the Pr value is best limited to 15-30%.

Calculation formula for regulating valve diameter

Liquid

Imperial

$$Cv = Q \sqrt{\frac{G}{P_1 - P_2}}$$

$$= Q \sqrt{\frac{G}{\Delta P}} \quad \dots\dots (1)$$

Metric

$$Cv = 1.17Q \sqrt{\frac{G}{P_1 - P_2}}$$

$$= 1.17Q \sqrt{\frac{G}{\Delta P}} \quad \dots\dots (1')$$

In the formula

Q = Maximum flow rate (gpm)
G = Specific gravity (water = 1)
P1 = Inlet pressure (psi)
P2 = Outlet pressure (psi)
 $\Delta P = P_1 - P_2$

Q = Maximum flow rate (m³/h)
G = Specific gravity (water = 1)
P1 = Inlet pressure (kgf/cm²)
P2 = Outlet pressure (kgf/cm²)

Note: P1 and P2 are the pressures at maximum flow rate.

Note: Cv = 1.17 Kv. Kv is the symbol for the flow coefficient of a regulating valve in my country.

Viscosity correction

For liquids with viscosities greater than 100 SSU (Saybolt seconds) or greater than 20 CST (centistokes), viscosity correction should be performed in the following order to calculate the required Cv value.

1. Ignoring the effects of viscosity, calculate Cv using formula (1) or (1').
2. Calculate the coefficient R using formulas (A) and (B) or (A') and (B').
3. From the viscosity correction curve, determine the Cv correction factor corresponding to the coefficient R.
4. Multiply this correction factor by the Cv calculated in the first step.
5. Then, select the appropriate control valve diameter from the Cv value list.

Calculation formula for coefficient R

Imperial

$$R = \frac{10000Q}{\sqrt{Cv \cdot Mcs}} \quad \dots\dots (A)$$

$$R = \frac{465000Q}{\sqrt{Cv \cdot Mssu}} \quad \dots\dots (B)$$

Metric

$$R = \frac{10000Q}{\sqrt{Cv \cdot Mcs}} \quad \dots\dots (A')$$

$$R = \frac{4204600Q}{\sqrt{Cv \cdot Mssu}} \quad \dots\dots (B')$$

Gas Properties Table

Name	Molecular formula	Molecular weight	Gas constant R kg·m kg·k	Valve body		Specific gravity at 0°C 760 mmHg (air = 1)	Boiling point TbK at 760 mmHg	Specific heat ratio X at 20°C and 760mmHg	Critical point		
				At 0°C 760 mmHg	At 20°C 760 mmHg				Temp Tc K	Pressure Pc kgf/m³	Density ρC kg/m³
Air (Dry)	N/A	28.96	29.28	1.2928	1.205	1.00	78.8	1.4*	132.42~ 132.52	38.4	328~ 320
Nitrogen	N ₂	28.0134	30.27	1.2506	1.165	0.9673	77.35	1.4*	126.1	34.6	312
Oxygen	O ₂	31.9988	26.5	1.4289	1.331	1.1053	90.17	1.397*	154.78	51.7	4265
Argon	Ar	39.948	21.23	1.7840		1.38	87.291	1.68	150.7	49.6	535
Neon	Ne	20.183	42.02	0.9000		0.6062	27.09	1.68	44.4	27.8	483
Helium	He	4.003	211.84	0.17847		0.1380	4.215	1.66	5.199	2.34	69
Krypton	Kr	83.40	10.12	3.6431		2.818	119.79	1.67	209.4	56.1	909
Xenon	Xe	131.30	6.46	5.89		4.53	165.02	1.666	289.75	59.9	1105
Hydrogen	H ₂	2.016	420.63	0.08988	0.084	0.06952	20.38	1.412*	32.976	13.2	31.45
Methane	CH ₄	16.043	52.86	0.7167	0.668	0.5544	111.7	1.315*	190.7	47.3	162
Ethane	C ₂ H ₆	30.07	28.20	1.3567	1.263	1.0494	184.52	1.18*	305.45	49.8	203
Propane	C ₃ H ₈	44.097	19.23	2.005	1.867	1.5509	231.05	1.13*	369.95	43.4	220
n-Butane	C ₄ H ₁₀	58.124	14.59	2.703		2.091	272.65	1.10*	425.15	38.71	228
Isobutane	C ₄ H ₁₀	58.124	14.59	2.675		2.0692	261.45	1.11*	409.15	37.2	222
n-Pentane	C ₅ H ₁₂	72.151	11.75	3.215		2.4869	309.25	1.07*	469.75	34.34	244
Ethylene	C ₂ H ₄	28.054	30.23	1.2604	1.174	0.975	169.45	1.22*	283.05	51.6	227
Propylene	C ₃ H ₆	42.081	20.15	1.914	1.784	1.48	225.45	1.15*	365.05	47.1	233
1-Butene	C ₄ H ₈	56.108	15.11	2.500		1.9338*	266.85	1.11*	419.15	40.99	233
cis-2-Butene	C ₄ H ₈	56.108	15.11	2.500		1.9338*	276.85	1.1214*	433.15	42.89	238
trans-2-Butene	C ₄ H ₈	56.108	15.11	2.500		1.9338*	274.05	1.1073*	428.15	41.83	238
Isobutylene	C ₄ H ₈	56.108	15.11	2.500		1.9338*	266.25	1.1058*	417.85	40.77	234
Acetylene	C ₂ H ₂	26.038	32.57	1.1717	1.091	0.9063	189.13 sublimation	1.24	309.15	63.7	231
Benzene	C ₆ H ₆	78.114	10.86	3.3		2.553	353.25	1.101	562.15	50.19	304
Carbon Monoxide	CO	28.0106	30.27	1.2584	1.165	0.9672	81.65	1.395	132.92	35.6	301
Carbon Dioxide	CO ₂	44.00995	19.27	1.977	1.842	1.5291	194.75 sublimation	1.295	304.19	75.28	468
Nitric Oxide	NO	30.0061	28.26	1.3401		1.0366	121.45	1.4	179.15	66.1	52
Nitrogen Dioxide	NO ₂	46.0055	18.43	2.055		1.59	294.35	1.31	431.35	103.3	570
Nitrous Oxide	N ₂ O	44.0128	19.27	1.9781		1.530	184.66	1.274	309.71	74.1	457
Hydrogen Sulfide	H ₂ S	34.07994	24.88	1.539	1.434	1.1904	212.85	1.32	373.55	91.8	373
Hydrogen Cyanide	HCN	27.0258	31.38	1.2246		0.947(3°C)	298.85	1.31(65°C)	456.65	54.8	200
Carbonyl Sulfide	COS	60.0746	14.12	2.712		2.105	222.95		378.15	63	
Ozone	O ₃	47.9982	17.67	2.144		1.658	161.25		261.05	69.2	537
Sulfur Dioxide	SO ₂	64.0628	13.24	2.727	2.726	2.264	263.15	1.25	430.65	80.4	524
Fluorine	F ₂	37.9968	22.32	1.695		1.31	85.03	1.358	172.15	172.15	473
Chlorine	Cl ₂	70.906	11.96	3.214	3.00	2.486	238.55	1.35	417.15	78.6	573
Methyl Chloride	CH ₃ Cl	50.488	16.8	2.3044		1.782	249.39	1.28	416.15	68.1	353
Ethyl Chloride	C ₂ H ₅ Cl	64.515	13.14	2.870		2.22	285.45	1.19 (16°C,0.3~0.5atm)	455.95	53.7	330
Ammonia	NH ₃	17.0306	49.79	0.771	0.719	0.5964	239.75	1.32	405.65	115.0	235
Freon-11	CCl ₃ F	137.3686	6.17	6.20		4.8	296.95	1.135	471.15	44.6	554
Freon-12	CCl ₂ F ₂	120.914	7.01	5.39		4.17	243.35	1.138	385.15	40.0	558
Freon-13	CClF ₃	104.4594	8.12	4.654		3.6	191.75	1.150(10°C)	302.05	39.4	578
Freon-113	C ₂ Cl ₃ F ₃	187.3765	4.53	8.274		6.4	320.75		487.25	34.80	576

*Values at 15.6°C

Table of Properties of Liquids

Name	Molecular formula	Molecular weight	Density ρ_{20} (kg/mm ³) at 20°C	Boiling point ρ_b (°C) at 760 mmHg	Critical point			Volume expansion coefficient $\mu \cdot 10^5(1/°C)$
					Temp Tc K	Pressure Pc kgf/m ³	Density ρ_C kg/m ³	
Water	H ₂ O	18.0	998.2	100.00	374.15	255.65	307	18
Mercury	Hg	200.6	13545.7	365.95	1460	107.6	5000	18.1
Bromine	Br ₂	159.8	3120	58.8	311	105.4	1180	113
Sulfuric Acid	H ₂ SO ₄	98.1	1834	340 decomposition				57
Nitric Acid	HNO ₃	63.0	1512	86.0				124
Hydrochloric Acid	HCl	36.47	1149.3					
Sulfolane	C ₄ H ₈ O ₂ S	120	1261(30°C)	285				
				56.2	235	48.6	268	143
Acetone	C ₃ H ₆ O	58.08	791	79.6	260	39.5		
Methyl Ethyl Ketone	C ₄ H ₈ O	72.11	803	181.8	419	62.6		
Phenol	C ₆ H ₆ O	94.1	1050(50°C)					
Carbon Disulfide	CS ₂	76.13	1262	46.3	277.7	75.5	440	119
Ethanolamine	HOCH ₂ CH ₂ NH ₂	61.1		170.5				
Methanol	CH ₃ OH	32.04	791.3	64.7	240	81.3	272	119
Ethanol	CH ₃ CH ₂ OH	46.04	789.2	78.3	243.1	64.4	275.5	110
Ethylene Glycol	HOCH ₂ CH ₂	62.1	1113	197.6				
n-Propanol	CH ₃ (CH ₂) ₂ OH	60.10	804.4	97.2	265.8	51.8	273	98
Isopropanol	(CH ₃) ₂ CHOH	60.10	785.1	82.2	273.5	54.9	274	
n-Butanol	CH ₃ (CH ₂) ₃ OH	74.12	809.6	117.8	287.1	50.2		
Acetonitrile	CH ₃ CN	41	783	81.6	274.7	49.2	240	
n-Pentanol	CH ₃ (CH ₂) ₄ OH	88.15	813.0	138.0	315.0			88
Acetaldehyde	CH ₃ CHO	44.06	783	20.2	188.0			
Propionaldehyde	CH ₃ CH ₂ CHO	58.08	808	48.9				
Cyclohexanone	C ₆ H ₁₀ O	98.15	946.6	155.7				
Diethyl Ether	(CH ₃ CH ₂) ₂ O	74.12	714	34.6	194.7	37.5	264	162
Glycerol	C ₃ H ₈ O ₃	92.09	1261.3	290 decomposition				50
o-Cresol	C ₇ H ₈ O	108.14	1020(50°C)	191.0	422.3	51.1		
m-Cresol	C ₇ H ₈ O	108.14	1034.1	202.2	432.0	46.5		
p-Cresol	C ₇ H ₈ O	108.14	1011(50°C)	202.0	426.0	52.6		
Methyl Formate	HCOOCH ₃	60.05	975	31.8	212.0	61.1	349	121
Methyl Acetate	CH ₃ COOCH ₃	74.08	934	57.1	235.8	47.9		
Methyl Propionate	CH ₃ CH ₂ COOCH ₃	88.11	915	79.1	261.0	40.8		
Formic Acid	HCOOH	46.03	1220	100.7				102
Acetic Acid	CH ₃ COOH	60.05	1049	118.1	312.5	59		
Propionic Acid	CH ₃ CH ₂ COOH	74.08	993	141.3	339.5	54.1	320	109
Aniline	C ₆ H ₅ NH ₂	93.13	1021.7	184.4	425.7	54.1	340	85
Propionitrile	CH ₃ CH ₂ CN	55.08	781.8	97.2	291.2	42.8		
Butyronitrile	CH ₃ (CH ₂) ₂ CN	69.11	790	117.6	309.1	38.6		
Thiophene	C ₄ H ₄ S	84.14	1065	84.1	317.3	49.3		
Dichloromethane	CH ₂ Cl ₂	84.93	1325.5	40.1	237.5	62.9		
Chloroform	CHCl ₃	119.38	1490	61.2	260.0	55.6	496	128
Carbon Tetrachloride	CCl ₄	153.82	1594	76.8	283.2	46.5	558	122
o-Xylene	C ₈ H ₁₀	106.16	880	177	358.1	38.1		97
m-Xylene	C ₈ H ₁₀	106.16	864	139.2	346	37.2		99
p-Xylene	C ₈ H ₁₀	106.16	861	138.1	345	36.1		102
Toluene	C ₆ H ₅ CH ₃	92.1	866	110.7	320.6	43.0	290	108
o-Chlorotoluene	C ₇ H ₇ Cl	126.6	1081	159				89
m-Chlorotoluene	C ₇ H ₇ Cl	126.6	1072	162.2				
Cyclohexane	C ₆ H ₁₂	84.1	778	80.8	280	41.3	273	120
Hexane	C ₆ H ₁₄	86.2	660	68.73	234.7	30.9	234	135
Heptane	C ₇ H ₁₆	100.2	684	98.1	267.0	27.9	235	124
Octane	C ₈ H ₁₈	111.2	702	125.7	296.7	25.4	233	114

Unit conversion table

Pressure

	Pa	mbar	bar	kg/cm ²	mmH ₂ O	mmHg	psi
1 Pa	1	0.01	1×10^{-5}	102×10^{-7}	0.102	0.0075	145×10^{-6}
1 mbar	100	1	0.001	102×10^{-5}	10.2	0.750	0.0145
1 bar	100000	10000	1	1.02	10200	750	14.5038
1 kg/cm ²	9810	981	0.981	1	10000	736	14.2233
1 mmH ₂ O	9.81	0.098	98.1×10^{-6}	0.0001	1	0.0736	0.001422
1 mmHg	13.3	1.33	0.00133	0.001359	13.59	1	0.01934
1 psi	6895.06	68.95	0.03895	0.07031	703.01	51.717	1

Energy

	J	Wh	kg·m	kcal	Btu	kW·h	hp·h
1 J	1	0.000278	0.102	0.000239	0.00095	27.8×10^{-8}	3.728×10^{-7}
1 Wh	3600	1	356	0.860	3.412	0.001	0.00134
1 kg·m	9.81	2.725×10^{-6}	1	0.00234	0.00929	2.725×10^{-6}	3.659×10^{-6}
1 kcal	4184	1.163	427	1	3.968	1.163×10^{-3}	0.00148
1 Btu	1052.6	0.2931	107.64	0.252	1	2.931×10^{-4}	0.393×10^{-3}
1 kW·h	3.6×10^6	1000	3.67×10^5	860	3412.5	1	1.3414
1 hp·h	2.686×10^6	746.2	273745	641	2544	0.7462	1

Power

	W	kW	kg·m/s	hp	kcal/h	Btu/min	Btu/h
1 W	1	0.001	0.102	1.341×10^{-3}	0.860	0.0568	3.41
1 kW	1000	1	101.97	1.341	860	56.85	3413
1 kg·m/s	9.81	9.81×10^{-3}	1	0.0131	8.424	0.5568	3.34
1 hp	746	0.746	76	1	642.4	42.462	2544
1 kcal/h	1.163	1.163×10^{-3}	0.119	0.00156	1	0.0661	3.97
1 Btu/min	17.606	0.0176	1.796	0.02355	15.13	1	62.5
1 Btu/h	0.293	0.293×10^{-3}	0.299	0.393×10^{-3}	0.252	0.016	1

Air Flow

	m ³ /h	m ³ /min	L/h	L/min	SCFM	SCIM	SCFH
1 m ³ /h	1	0.016	1000	16.67	0.59	35.34	1022.5
1 m ³ /min	60	1	60000	1000	35.4	21.20	61.3×10^{-3}
1 L/h	0.001	16×10^{-6}	1	0.0167	5.9×10^{-4}	35.34×10^{-2}	102
1 L/min	0.06	0.001	60	1	0.0354	2.12	61.17
1 SCFM	1.695	0.0282	1695	28.25	1	60	1728
1 SCIM	0.98×10^{-3}	16.3×10^{-6}	0.95	0.016	0.00058	0.0347	1
1 SCFH	0.0283	4.72×10^{-4}	28.3	0.472	0.0167	1	28.8

Water Flow

	m ³ /h	L/s	gpm	m ³ /min	L/min	L/h
1 m ³ /h	1	0.278	4.41	0.0167	16.7	1000
1 L/s	3.6	1	15.876	0.06	60	3597
1 gpm	0.227	0.063	1	0.0038	3.79	227
1 m ³ /min	60	3.60	263.16	1	1000	60240
1 L/min	0.06	0.0167	0.254	0.001	1	60.2
1 L/h	0.001	0.278×10^{-3}	0.0044	0.0166×10^{-3}	0.0166	1

PN1.6MPa (16 pressure) Plate Type Flat Welded Steel Pipe Flange mm

DN	Pipe OD A1		Connection Dimensions					Sealing Surface Dimensions		Flange Thickness C	Flange Inner Diameter B1		Groove Width b	Flange Theoretical Weight Series 2 kg
			Flange OD Series 1/Series 2 D	Bolt Hole Center Diameter K	Bolt Hole Diameter Series 1/Series 2 L	Bolts/Studs								
	International A	Domestic B				Quantity n	Thread Th Series 1/Series 2	d	f		A	B		
10	17.2	14	90	60	14	4	M12	40	2	14	18	15	3	0.55
15	21.3	18	95	65	14	4	M12	45	2	14	22	19	3	0.71
20	26.9	25	105	75	14	4	M12	55	2	16	27.5	26	3	0.87
25	33.7	32	115	85	14	4	M12	65	2	18	34.5	33	4	1.18
32	42.4	38	140/135	100	18	4	M16	78	2	18	43.5	39	4	1.60
40	48.3	45	150/145	110	18	4	M16	85	3	20	49.5	46	4	2.00
50	60.3	57	165/160	125	18	4	M16	100	3	22	61.5	59	4	2.61
65	76.1	76	185/180	145	18	4	M16	120	3	24	77.5	78	5	3.45
80	88.9	89	200/195	160	18	8	M16	135	3	24	90.5	91	5	3.71
100	114.3	108	220/215	180	18	8	M16	155	3	24	116	110	5	4.80
125	139.7	133	250/245	210	18	8	M16	185	3	28	141.5	135	5	6.47
150	168.3	159	285/280	240	23	8	M20	210	3	28	170.5	161	5	7.92
175		194	310	270	23	8	M20	240	3	28		196	6	8.81
200	219.1	219	340/335	295	23	12	M20	265	3	30	221.5	222	7	10.10
225		245	365	325	23	12	M20	295	3	30		248	8	11.20
250	273	273	405	355	26/25	12	M24/M22	320	3	32	276.5	276	9	15.70
300	323.9	325	460	410	26/25	12	M24/M22	375	4	32	327.5	328	9	18.10
350	355.6	377	520	470	26/25	16	M24/M22	436	4	34	359.5	380	10	23.30
400	406.4	426	580	525	30	16	M27	485	4	38	411	430	10	31.00
450	457	480	640	585	30	20	M27	515	4	42	462	484	10	40.20
500	508	530	715/705	650	34	20	M30	608	4	48	513.5	534	10	55.20
600	610	630	840	770	36/41	20	M33/M36	718	5	50	616.5	634	10	80.80
700	711	720	910	840	36/41	24	M33/M36	788	5	50	715	724	10	106.0
800	813	820	1025/1020	950	39/41	24	M36	898	5	52	817	824	10	130.5
900	914	920	1125/1120	1050	39/41	28	M36	998	5	44	918	924	10	91
1000	1016	1020	1255	1170	42/48	28	M39/M42	1110	5	46	1020	1024	10	127
1100		1120	1370	1280	42	28	M39	1222	5	50		1124	10	150
1200	1219	1220	1485	1390	48/54	32	M45/M48	1325	5	52	1223	1224	12	186
1300		1320	1585	1490	54	32	M48	1425	5	54		1324	12	215
1400	1422	1420	1685	1590	48/54	36	M45/M48	1525	5	58	1426	1424	14	245
1500		1520	1820	1710	54	36	M48	1640	5	60		1524	14	320
1600	1626	1620	1920	1820	55/58	40	M52	1750	5	64	1630	1624	16	360
1750			2080	1970	58	44	M52	1900	5	66			16	400
1800	1829	1820	2130	2020	55/58	44	M52	1950	5	68	1833	1824	17	430
2000	2032	2020	2345	2230	60	48	M56	2150	5	70	2036	2024	18	515

※Series 1 National Standard GB/T9119-2000/Series 2 Mechanical Industry Standard JB/T81-94

PN2.5MPa (25 pressure) Plate Type Flat Welding Steel Pipe Flange mm

DN	Pipe OD A1		Connection Dimensions					Sealing Surface Dimensions		Flange Thickness C	Flange Inner Diameter B1		Groove Width b	Flange Theoretical Weight Series 2 kg
			Flange OD Series 1/Series 2 D	Bolt Hole C enter Diameter K	Bolt Hole Diameter Series 1/Series 2 L	Bolts/Studs								
	Internat- ional A	Domes- tic B				Quan- tity n	Thread Th Series 1/Series 2	d	f		A	B		
10	17.2	14	90	60	14	4	M12	40	2	14	18	15	3	0.64
15	21.3	18	95	65	14	4	M12	45	2	14	22	19	3	0.80
20	26.9	25	105	75	14	4	M12	55	2	16	27.5	26	3	0.99
25	33.7	32	115	85	14	4	M12	65	2	18	34.5	33	4	1.18
32	42.4	38	140/135	100	18	4	M16	78	2	20	43.5	39	4	1.96
40	48.3	45	150/145	110	18	4	M16	85	3	22	49.5	46	4	2.60
50	60.3	57	165/160	125	18	4	M16	100	3	24	61.5	59	4	2.71
65	76.1	76	185/180	145	18	8	M16	120	3	24	77.5	78	5	3.22
80	88.9	89	200/195	160	18	8	M16	135	3	26	90.5	91	5	4.06
100	114.3	108	235/230	190	23	8	M20	160	3	28	116	110	5	6.00
125	139.7	133	270	220	26/25	8	M24/M22	188	3	30	141.5	135	5	8.26
150	168.3	159	300	250	26/25	8	M24/M22	218	3	30	170.5	161	5	10.40
175		194	330	280	26/25	12	M24/M22	248	3	32		196	6	11.90
200	219.1	219	360	310	26/25	12	M24/M22	278	3	32	221.5	222	7	14.50
225		245	395	340	30	12	M27	302	3	34		248	8	17.00
250	273	273	425	370	30	12	M27	332	3	34	276.5	276	9	18.90
300	323.9	325	485	430	30	16	M27	390	4	36	327.5	328	9	26.80
350	355.6	377	555/550	490	34	16	M30	448	4	42	359.5	380	10	34.35
400	406.4	426	620/610	550	36/34	16	M33/M30	505	4	44	411	430	10	44.90
450	457	480	670/660	600	36/34	20	M33/M30	555	4	48	462	484	10	51.92
500	508	530	730	660	36/41	20	M33/M36	610	4	52	513.5	534	10	67.30
600	610	630	845/840	770	41	20	M36	718	5	56	616.5	634	10	95.20
700	711	720	960/955	875	42/48	24	M39/M42	815	5	60	715	724	10	116
800	813	820	1085/1070	990	48	24	M45/M42	930	5	64	817	824	10	150.2
900	914	920	1185/1180	1090	48/54	28	M45/M48	1025	5	58	918	924	10	160
1000	1016	1020	1320/1305	1210	55/58	32	M52	1140	5	62	1020	1024	10	210
1100		1124	1425	1315	55	28	M52	1240	5	66		1124	10	260
1200	1219	1220	1530/1525	1420	55/58	32	M52	1350	5	70	1223	1224	12	300
1300		1320	1645	1530	65	32	M56	1450	5	74		1324	12	355
1400	1422	1420	1755/1750	1640	60/65	36	M56	1560	5	76	1426	1424	14	450
1500		1520	1865	1750	60	36	M56	1670	5	80		1524	14	530
1600	1626	1620	1975	1860	60	40	M56	1780	5	84	1630	1624	16	570
1800	1829	1820	2130	2070	68	44	M64	1985	5	90	1833	1824	17	700
2000	2032	2020	2425	2300	68	48	M64	2210	5	96	2036	2024	18	900

※Series 1 National Standard GB/T9119-2000/Series 2 Mechanical Industry Standard JB/T81-94

**Series 1 National Standard GB/T9115.2-2000 /
Series 2 Mechanical Industry Standard JB/T82.2-94
PN 4.0MPa (40 pressure) Concave and convex face welding steel pipe flange mm**

DN	Flange welding end outer diameter (pipe outer diameter) A1		Connection Dimensions				Sealing surface size				Flange thickness C	Flange inner diameter B	Flange height H	Flange neck				Flange theoretical weight series 2		
	Internal tube A	Dome-tic B tube	Flange OD Series 1/ Series 2 D	Bolt Hole C enter Diameter Series 1/ Series 2 K	Bolt Hole Diameter Series 1/ Series 2 L	Bolts/Studs		X Convex series 1/ series 2	X Concave Series 1/ Series 2	f				f1 f2	Neck diameter Nmax	Flange welding end wall thickness S	Straight edge HI	Corner radius R	A Type	B Type
						Quantity n	Thread Th Series 1/ Series 2													
10	17.2	14	90	60	14	4	M12	40	34	35	2	4	26	2.3	6	3	0.77	0.67		
15	21.8	18	95	65	14	4	M12	45	39	40	2	4	30	3.2	6	3	0.87	0.77		
20	26.9	25	105	75	14	4	M12	55	50	51	2	4	38	3.2	6	4	1.09	0.97		
25	33.7	32	115	85	14	4	M12	65	57	58	2	4	45	3.2	6	4	1.31	1.18		
32	42.4	38	140/135	100	18	4	M12	78	65	66	2	4	56	3.6	6	5	2.17	1.98		
40	48.3	45	150/145	110	18	4	M16	85	75	76	3	4	64	3.6	7	5	2.51	2.14		
50	60.3	57	165/160	125	18	4	M16	100	87	88	3	4	76	4	8	5	3.34	2.92		
65	76.1	76	185/180	145	18	4	M16	120	109	110	3	4	96	5	10	6	4.34	3.85		
80	88.9	89	200/195	160	18	8	M16	135	120	121	3	4	112	5.6	12	6	5.52	5.03		
100	114.3	108	235/230	190	23	8	M20	160	149	150	3	4.5	138	6.3	12	6	8.39	7.71		
125	139.7	133	270	220	26/25	8	M24/M22	188	175	176	3	4.5	160	6.3	12	6	11.06	10.27		
150	168.3	159	300	250	26/25	8	M24/M22	218	203	204	3	4.5	186	7.1	12	6	14.16	13.30		
(175)		194	350	295	30	12	M27	258	233	234	3	4.5	226	7.1	12	6	21.80	20.97		
200	219.1	219	375	320	30	12	M27	282	259	260	3	4.5	250	8	16	8	25.56	24.72		
(225)		245	415	355	34	12	M30	315	286	287	3	4.5	280	8	16	8	32.48	31.60		
250	273	273	450/445	385	34	12	M30	345	312	313	3	4.5	310	10	18	10	39.87	39.00		
300	323.9	325	515/510	450	34	16	M30	408	363	364	4	4.5	368	10	18	10	55.97	53.21		
350	355.9	377	580/570	510	36/34	16	M33/M30	465	421	422	4	5	418	11	20	10	75.30	72.29		
400	406.4	426	660/655	585	41	16	M36	535	473	474	4	5	480	12.5	20	10	112.02	108.44		
450	457	480	685/680	610	41	20	M36	560	523	524	4	5	530	14.2	20	12	112.82	109.70		
500	508	530	755	670	42/48	20	M39/M42	612	575	576	4	5	580	16	20	12	142.70	138.60		
600	610	630	890	795	48/54	20	M45/M48	730	675/677	676/678	5	6	700	17.5	20	20	167	160		
700	711	720	995	900	48/54	24	M45/M48	835	777/767	778/768	5	6	780	19	20	20	275	265		
800	813	820	1140/1135	1030	58	24	M52	960	882/875	883/876	5	6	910	20	20	22	410	400		

**Series 1 National Standard GB/T9115.2-2000 /
Series 2 Mechanical Industry Standard JB/T82.2-94
PN 6.3MPa (64 pressure) Concave and convex face welding steel pipe flange mm**

DN	Flange welding end outer diameter (pipe outer diameter) A1		Connection Dimensions				Sealing surface size				Flange thickness C	Flange inner diameter B	Flange height H	Flange neck				Flange theoretical weight series 2		
	Internal tube A	Dome-tube B	Flange OD Series 1/Series 2 D	Bolt Hole C enter Diameter Series 1/Series 2 K	Bolt Hole Diameter Series 1/Series 2 L	Bolts/Studs		X Convex series 1/ series 2	X Concave Series 1/ Series 2	f				f1 f2	Neck diameter Nmax	Flange welding end wall thickness S	Straight edge HI	Corner radius R	A Type	B Type
						Quantity n	Thread Th Series 1/Series 2													
10	17.2	14	100	70	14	4	M12	50	34	35	2	4	3	6	3	1.12	1.02			
15	21.3	18	105	75	14	4	M12	55	39	40	2	4	3.2	6	3	1.25	1.14			
20	26.9	25	130/125	90	18	4	M16	68	50	51	2	4	3.2	6	4	2.12	1.95			
25	33.7	32	140/135	100	18	4	M16	78	57	58	2	4	3.2	6	4	2.64	2.46			
32	42.4	38	155/150	110	23	4	M20	82	65	66	2	4	3.6	6	5	3.50	3.28			
40	48.3	45	170/165	125	23	4	M20	95	75	76	3	4	3.6	7	5	4.35	3.91			
50	60.3	57	180/175	135	23	4	M20	105	87	88	3	4	4	8	5	5.29	4.80			
65	76.1	76	205/200	160	23	8	M20	130	109	110	3	4	5	10	6	7.00	6.43			
80	88.9	89	215/210	170	23	8	M20	140	120	121	3	4	5.6	12	6	8.07	7.50			
100	114.3	108	250	200	23	8	M24/M22	168	149	150	3	4.5	6.3	12	6	11.51	10.80			
125	139.7	133	295	240	26/25	8	M27	202	175	176	3	4.5	6.3	12	6	18.02	17.09			
150	168.3	159	345/340	280	30	8	M30	240	203	204	3	4.5	7.1	12	6	26.45	25.29			
(175)		194	375/370	310	34	12	M30	270	233	234	3	4.5	7.1	12	6	30.63	29.61			
200	219.1	219	415/405	345	34	12	M33/M30	300	259	260	3	4.5	8	16	8	39.68	38.51			
(225)		245	430	370	36/34	12	M33/M30	325	286	287	3	4.5	8	16	8	43.34	42.32			
250	273	273	470	400	36/41	12	M33/M30	352	312	313	3	4.5	10	18	10	53.64	52.47			
300	323.9	325	530	460	36/41	16	M33/M36	412	363	364	4	4.5	10	18	10	73.10	69.97			
350	355.9	377	600/595	525	41	16	M36	475	421	422	4	5	17.5	20	10	103.50	100.10			
400	406.4	426	670	585	42/48	16	M39/M42	525	473	474	4	5	20	20	10	143.30	139.90			
450	457	480	715	630	48	20	M42	570	523	524	4	5	22.5	20	12	160	155			
500	508	530	800	705	48/54	20	M45	640	575	576	4	5	22.5	20	12	215	210			
600	610	630	930	820	58	20	M52	750	675/677	676/678	5	6	25	20	20	320	310			
700	711	720	1045	935	58	24	M52	865	777/767	778/768	5	6	25	20	20	450	435			
800	813	820	1165	1050	62	24	M56	980	882/875	883/876	5	6	25	20	22	540	525			

**Series 1 National Standard GB/T9115.2-2000 /
Series 2 Mechanical Industry Standard JB/T82.2-94
PN 10.0MPa (100 pressure) Concave and convex face welding steel pipe flange mm**

DN	Flange welding end outer diameter (pipe outer diameter) A1		Connection Dimensions			Sealing surface size			Flange thickness C	Flange inner diameter B	Flange height H	Flange neck				Flange theoretical weight series 2		
	Inter- national tube	Dome- stic B tube	Flange OD Series 1/Series 2 D	Bolt Hole C enter Diameter Series 1/Series 2 K	Bolt Hole Diameter Series 1/Series 2 L	Quant- ity n	Thread Th Series 1/Series 2	d				X Convex series 1/ series 2	X Concave Series 1/ Series 2	f	f1 f2	Neck diameter Nmax	Flange welding end wall thickness S	Straight edge H1
10	17.2	14	100	70	14	4	M12	50	34	35	2	4	34	3	6	3	1.12	1.01
15	21.3	18	105	75	14	4	M12	55	39	40	2	4	39	3.2	6	3	1.37	1.26
20	26.9	25	130/125	90	18	4	M16	68	50	51	2	4	50	3.6	6	4	2.30	2.13
25	33.7	32	140/130	100	18	4	M16	78	57	58	2	4	57	3.6	6	4	2.66	2.67
32	42.4	38	155/150	110	23	4	M20	82	65	66	2	4	65	3.6	8	5	3.50	3.28
40	48.3	45	170/165	125	23	4	M20	95	75	76	3	4	75	4	8	5	4.72	4.28
50	60.3	57	195	145	26/25	4	M24/M22	112	87	88	3	4	87	6	10	5	6.58	6.02
65	76.1	76	220	170	26/25	8	M24/M22	138	109	110	3	4	109	7	12	6	9.20	8.60
80	88.9	89	230	160	26/26	8	M24/M22	148	120	121	3	4	120	7	12	6	10.61	9.97
100	114.3	108	265	210	30	8	M27	172	149	150	3	4.5	149	8	12	6	15.54	14.70
125	139.7	133	315/310	250	34	8	M30	210	175	176	3	4.5	175	10.5	12	8	25.10	24.00
150	168.3	159	355/350	290	34	12	M30	250	203	204	3	4.5	203	11.5	16	10	34.43	33.26
(175)		194	385/380	320	34	12	M30	280	233	234	3	4.5	233	11.5	16	10	41.60	40.47
200	219.1	219	430	360	36/41	12	M33/M36	312	259	260	3	4.5	259	14.5	16	10	57.14	55.80
(225)		245	470	400	41	12	M36	352	286	287	3	4.5	286	14.5	16	10	73.30	71.90
250	273	273	505/500	430	41	12	M36	382	312	313	3	4.5	312	18.5	18	10	89.30	87.90
300	323.9	325	585	500	42/48	16	M45/M48	442	368	364	4	4.5	368	20.5	18	12	137.45	130.10
350	355.9	377	655	560	48/54	16	M45/M48	498	421	422	4	5	421	22.5	20	12	186.00	175.20
400	406.4	426	715	620	48/54	16	M45/M48	558	473	474	4	5	473	25	20	12	223.50	218.50
450	457	480	770	675	58	20	M52	615	523	524	4	5	523	25	20	18	280	270
500	508	530	870	760	58	20	M52	690	575	578	4	5	575	30	22	18	350	335
600	610	630	990	875	58	24	M52	800	675/677	676/678	5	6	675/677	30	22	18	460	445



HGZK VALVE is a leading comprehensive manufacturer specializing in the development and production of pneumatic and electric actuators and valves, including control valves.



This catalog features our extensive range of products, primarily covering pneumatic control valves, electric control valves, self-operated control valves, the CV3000 series, V-shaped ball valves, quick-disconnect valves, electric two-way valves for building automation, and other related instrumentation for industrial process control.

With a portfolio of over 140 series and 1,700 specifications, our solutions are engineered to meet diverse and demanding application needs. They are widely employed in automation control systems across numerous industries such as papermaking, petrochemicals, power generation, metallurgy, environmental protection, heating, pharmaceuticals, and building automation.



www.hgzk-valve.com



sales@hgzkvalve.com



Building 1, National Incubator, Sipingshan Road, Dingmao Street, New District, Zhenjiang City, Jiangsu Province, China