

REB 500 – decentralized numerical busbar protection with extended functionality

Digital, real-time communication technology has provided a platform for the development of a fully numerical, decentralized busbar and breaker-failure protection system. Dubbed REB 500, it is based on the concept of remote, bay-oriented data acquisition and preprocessing and is suitable for all kinds and sizes of substations. REB 500 offers distributed functionality plus enhanced reliability and performance. The decentralized arrangement of the protection saves space and reduces wiring, making it easier to upgrade or extend substations. With their enhanced capability, the reduced hardware, and the many other advantages of numerical technology, protection schemes based on REB 500 offer both technical and cost benefits over their lifetime. Experience with protection systems already operating in the field has been very positive and confirms the flexibility and exceptional performance of REB 500.

The architecture of the numerical busbar protection (NBP) system provides greater flexibility than conventional busbar protection schemes. Commissioning and maintenance therefore require less time and are more user-friendly than in the past.

Additional features of the numerical system are breaker-failure protection, disturbance recording and diverse bay and back-up protection functions. The bay-oriented functions work autonomously even when the central unit is blocked.

The system can be modified or extended simply by adding extra bay units

and CPU capability. Using the man-machine interface, the new configuration and settings can then be transferred to the system and stored.

Majda Ilar
Beat Reimann
Dieter Brunner

ABB Network Partner

Busbar protection

The busbar protection has to satisfy the highest requirements with regard to reliability, security, selectivity, speed, measurement and versatility, under consideration of all possible busbar switching conditions.

The disconnection of a busbar which is in operation can have a strong effect on the stability of a power system, and in the worst case even cause total failure of the power supply to a complete region. Short-circuits on a busbar can moreover cause substantial damage to the installed equipment, since the fault currents can reach values of several ten-thousand amperes, depending on the source of the supply and actual circumstances. For this reason, busbar protection systems have to provide a much higher level of security and work at a much faster speed than other types of protection.

Busbar protection systems

The operation and zone selectivity of the busbar protection are based on comparison of the current in all incoming and outgoing feeders of a busbar.

This principle of measurement has been used successfully for many years, and systems employing it are referred to as current differential protection or current balance protection. It can be employed in low- as well as high-impedance differential protection. Both have their justification, and specific technical characteristics allow optimized applications in each case. Other factors influencing the choice of protection can be national or traditional practices, and the configuration of the primary system being protected.

Security is often increased by choosing two different measurement principles, each with its own independent criteria. A 'two out of two' basis is also a guarantee of safe and selective protection when a numerical platform is used.

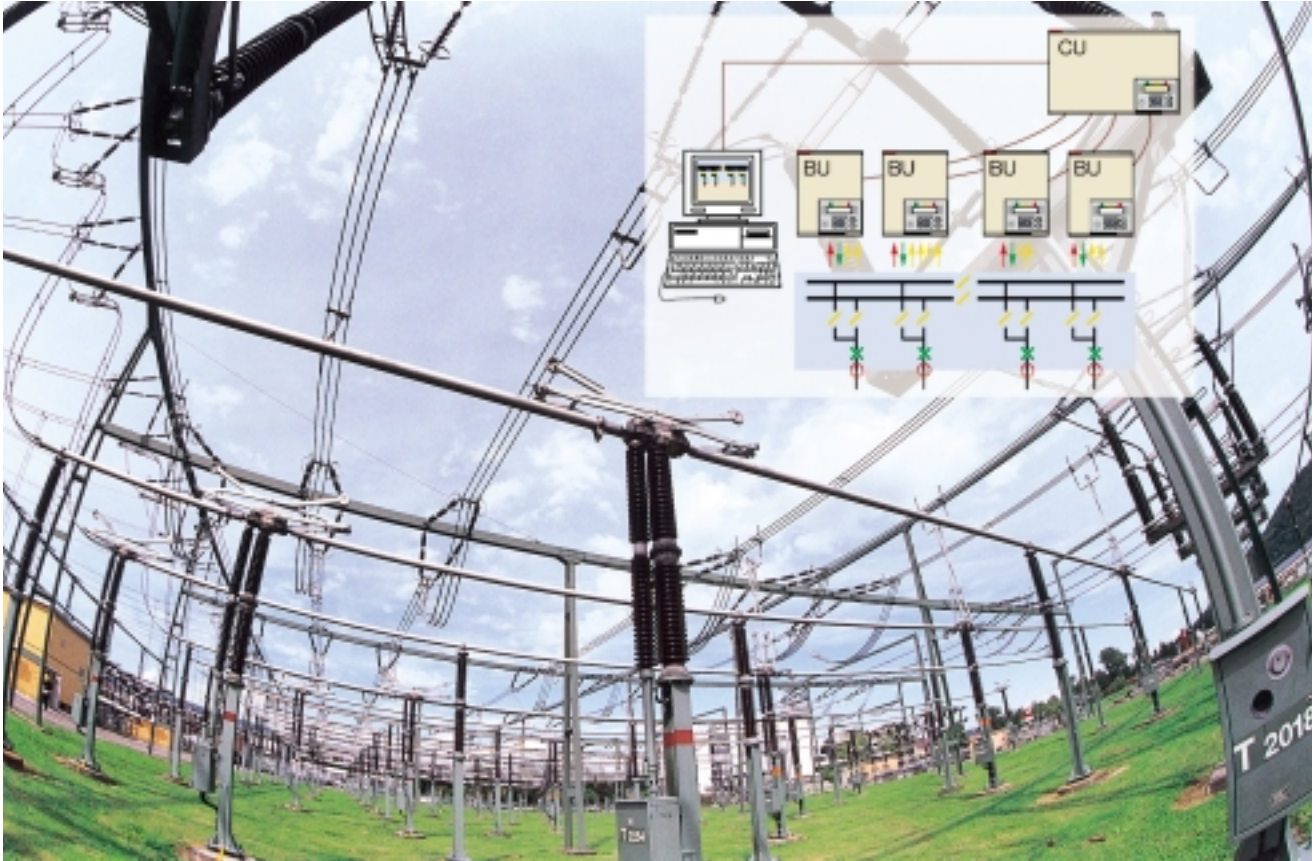

Substation with the distributed REB 500 numerical busbar protection system

1

BU Bay unit CU Central unit

High-impedance protection

The differential protection arrangement has a positive effect on the system stability due to the high-ohm resistor at the input. The voltage drop across this resistor is used in the evaluation.

In high-voltage applications where the highest priority is given to security, the usual practice is to install an additional high-impedance protection system and to connect it to the protection circuit as a so-called ‘check zone’. This provides a second trip criterion, but also requires an additional set of suitable current transformer (CT) cores as well as hard-wired connections for each feeder. The CT cores have to meet the following requirements:

- They must be dedicated, ie not shared with other protection relays.

- They must have identical CT transformation ratios.
- They must have a low-resistance secondary winding.
- The magnetizing current must be low.

In general, the CTs have to comply with BS 3938, class X, or the new class TPS stipulated by IEC.

It is a tradition in some countries to use high-impedance protection for double busbars. Unfortunately, however, to provide selectivity for every possible busbar configuration, the secondary CT circuits have to be switched via the auxiliary contacts of the disconnector (and/or additional interposing relays). Switching has to take place very fast, as under certain circumstances the CT core could become open-circuited and

subsequently destroyed due to the high voltage across the secondary winding.

Also, since a relatively high voltage (several kV) lies across the high impedance when an internal busbar fault occurs, the high-impedance relay itself has to be protected using external voltage dependable resistors (VDR) and short-circuit contacts.

Thus, in addition to a high-impedance protection system requiring a considerable investment in time for maintenance and project engineering, a substantial amount of additional equipment also has to be installed. All in all, it cannot be described as user-friendly, although the initial hardware costs appear to be low. Another factor is the cost of the additional CT core sets, which has to be in-

cluded in the total cost calculation for a specific protection system.

Low-impedance protection

This type of differential protection is the preferred type for single and multiple busbars, with or without a transfer bus. The main reasons for this are:

- No special CT cores are required.
- The CT transformation ratio can be different for each feeder. It is normally sufficient to use 30-VA protection cores designed to Standard 5P20.
- The CT core can be shared with other protection relays.
- The secondary circuits are never switched, ie they cannot be opened.
- The CT wiring is monitored internally by means of differential current alarm measurements.
- The disconnector positions are monitored internally to check their plausibility.

The low-impedance ABB busbar protection systems (INX5 and the new REB 500) employ advanced, proven measurement principles featuring a stabilized differential current measurement and a directional phase comparison evaluation (each performed individually per phase). By combining these two measurements in the tripping logic, a very high level of security is achieved without having to duplicate or add check zones.

The application of low-impedance busbar protection systems is comparatively simple, since all of the modules required for the protection are integrated in the system together with clearly defined interfaces for the connection to the substation, and the system as a whole can be fully tested in the factory prior to delivery. The result is a substantial reduction in secondary costs, eg for the overall substation planning, cubicle wiring, documentation and commissioning and maintenance.

Another advantage is that system monitoring is simple, with either an integrated automatic test facility or, as in the

REB 500 numerical system, internal supervisory algorithms being used.

Other possible features include disturbance recording, breaker-failure protection and earth-fault protection, plus overcurrent protection as a back-up function.

Application of numerical protection principles

Many power plants and substations are currently undergoing modernization. Hard-wired connections are being replaced by fiber-optic links, while personal computers are being installed to allow operators to automatically monitor and control the substations. Information about the installation and its operation is transmitted over signal links to different levels in the substations or to the national dispatching center. The result is more economic operations control and management plus lower life cycle costs for the installation.

The REB 500 numerical busbar protection supports the extension of primary systems by reducing the cabling and distributing the functionality, thereby minimizing the changes that need to be made to the hardware. Station downtime is also reduced.

REB 500 decentralized numerical busbar protection

System structure

Depending upon the user requirements, the REB 500 numerical busbar protection can be either bay-oriented (ie decentralized) or installed in the conventional way (in a central location). The latter is mainly used for retrofit projects [1, 2].

The decentralized installation of the bay units (BUs) in the bay control and protection cubicle close to the primary equipment results in short connections to the high-voltage apparatus **1**. Each BU is connected via fiber-optic cables to the central unit.

The central unit collects data from the BUs via the process bus and runs the busbar protection algorithms. The bundles of copper wires used previously have been replaced by fiber-optic links, thus solving the problems that can be caused by electromagnetic interference.

Bay unit

The BU is the interface to the switchgear installed in a bay and acts as a data acquisition unit, since all the information about the currents and voltages, as well as about the disconnector and circuit-breaker positions, is provided here. In addition, it represents the point at which the power system is separated electrically from the control equipment.

Every BU has the current inputs required for the busbar protection scheme. Additional voltage inputs are available for disturbance recording. All the analogue input signals are filtered and converted to digital signals by the analogue input and preprocessing (AIP) modules. The sampling rate of 2,400 Hz also allows the detection of saturated current signals.

The binary input/output modules (BIO) detect and process the positions of disconnectors and bus couplers, blocking signals, start signals for the breaker-failure protection, external resetting signals, etc. The BIOs operate in a wide range of auxiliary voltages.

The BUs convert the sampled current values into current phasors for each phase and transmit them to the central unit for further processing at intervals defined by the protection algorithms. Short tripping times are ensured by fast, deterministic communication between the BUs and the central unit as well as by the efficient algorithms.

Central unit

The central unit is responsible for the overall processing and the trip decisions. When it detects a busbar fault, it trans-

mits a trip signal to all the BUs in the respective busbar zone.

The hardware structure of the REB 500 busbar protection system is shown in 2. Each of the units (AIP, BIO, CMP, CSP) has at least one microprocessor. This keeps the software module distribution flexible. The software is split into application software, which provides the system functionality, and diagnostic modules, which are responsible for the start-up, self-supervision, event recording, system blocking and shut-down functions.

The central unit takes care of the system configuration, busbar replica, assignment of the bays within the system, operating parameters, management of the process bus, and synchronization and communication with the station control system. The busbar replica and the changes in the protection zones are adapted dynamically on the basis of the process data provided by the BUs.

Protection algorithms

To ensure secure, dependable protection, the measurements are carried out according to two different, independent measuring principles.

The first measuring principle makes use of a *stabilized differential current algorithm*. The currents are evaluated individually for each of the phases and each section of the busbar protection zone. The differential current I_{Diff} and the restraint current I_{Rest} have to fulfil the following two conditions for the detection of an internal fault:

$$k_{st} = \frac{I_{Diff}}{I_{Rest}} = \frac{\left| \sum_{n=1}^m I_{Ln} \right|}{\sum_{n=1}^m |I_{Ln}|} > k_{stmax} \quad I_{Diff} > S_D$$

I_{Ln} Fundamental frequency according to Fourier in busbar feeder n of line L

k_{st} Stabilizing factor

k_{stmax} Limit of stabilizing factor

L Conductor
 m Number of busbar feeders
 n Busbar feeder
 S_D Threshold for differential current
 The calculations take place in the central unit, which also puts the resulting decisions into effect.

The second measuring principle is a *directional phase current comparison*. This compares the phasors of the currents in all the feeders connected to a busbar section. In the event of an internal fault, all of the feeder currents have almost equal angles.

If differences of about 180° exist between the feeder currents, the system is

either in the normal operating mode or an external fault has occurred.

If the minimum phase difference $\Delta\varphi$ between all combinations of feeder phase angles is smaller than the tripping angle for the phase comparison $\Delta\varphi_{min}$, the algorithm will have detected an internal fault.

$$\Delta\varphi < \Delta\varphi_{min}$$

Empirically, $\Delta\varphi_{min} = 74^\circ$ has been shown to be the optimum threshold value for the tripping characteristic. This angle requires no station-specific settings.

The evaluation of the measurements is shared between the BUs and the central

Simplified overview of the hardware structure of the REB 500 protection system



1	Primary system (switchgear)	BU	Bay unit
2	Bay	CMP	Central unit master processor
3	Busbar	CSP	Central unit slave processors
		CT	Current transformers
AIP	Analogue input and preprocessing units	CU	Central unit
BIO	Binary input/output units	PB	Fiber-optic process buses

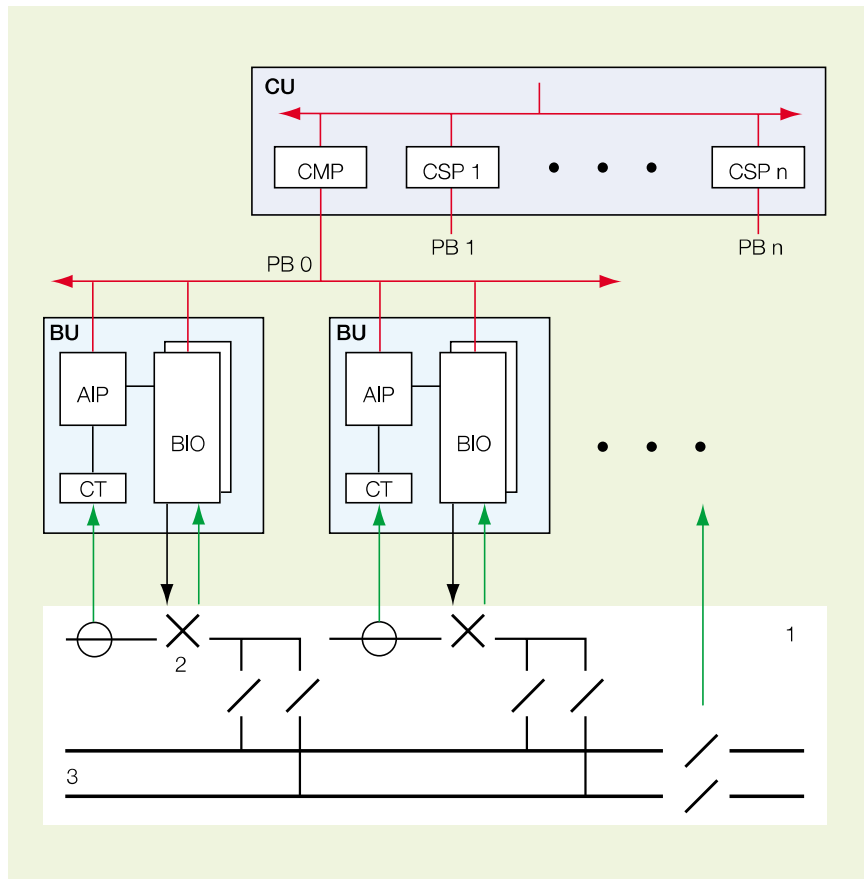

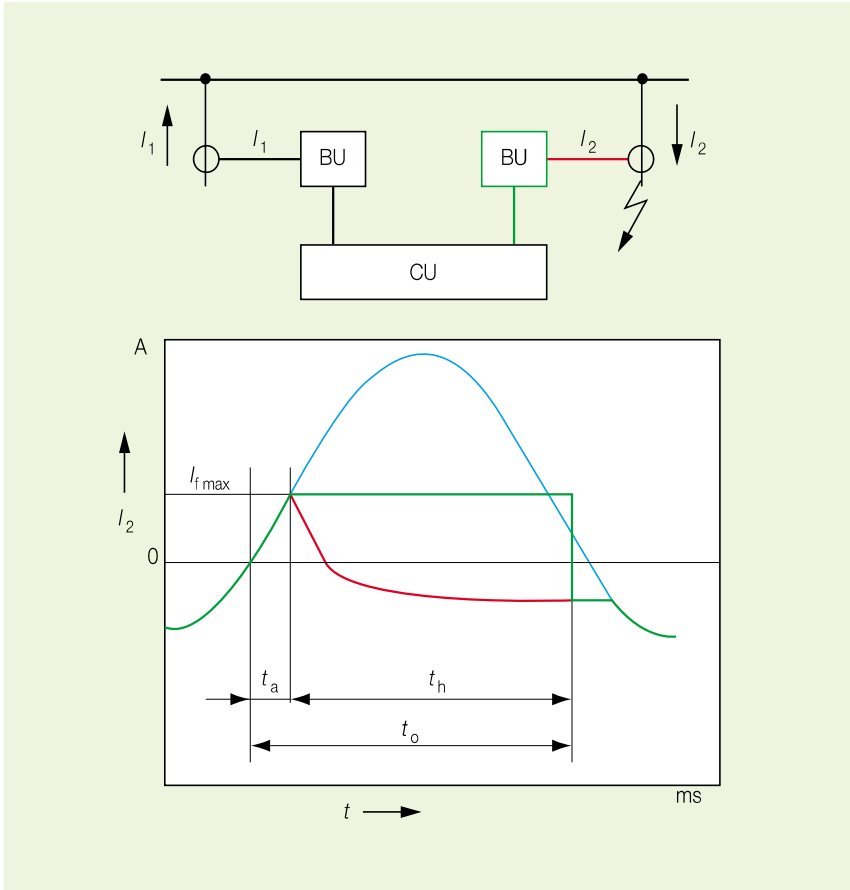

Principle of the static maximum-value holding method

Blue Primary current, feeder 2
 Red Saturated secondary current I_2
 Green Saturated secondary current I_2 after maximum value holding

I_1 Primary current, feeder 1
 I_{fmax} Max. current value in sampling window
 t_a Rise time
 t_h Holding time
 t_o Operating time of the holding function

BU Bay unit
 CU Central unit

unit. The BUs perform the preprocessing and all other bay-specific tasks.

The algorithms process the complex current phasors obtained by digital filtering and which are based only on the fundamental frequency.

Current transformer saturation

One of the main requirements a busbar protection scheme has to fulfil is proper behaviour in the case of current transformer saturation. The NBP is largely insensitive to CT saturation phenomena due to a special method applied prior to

the Fourier filtering. 3 shows the signal correction principle for saturated current signals using the maximum-value holding method.

This method works in that the maximum current value I_{fmax} is extracted from the sample window and held for a defined holding time t_h . The current value is held either at the maximum value I_{fmax} or a proportional value $v \cdot I_{fmax}$. The factor v depends on the rise time t_a , ie the time interval between the last zero crossing and the maximum value of I_{fmax} .

Additional functions

Additional functions provided by the system besides the busbar protection function can be activated as required.

Overcurrent release

An additional tripping criterion can be integrated in each BU via the overcurrent release function. The criterion is parameterized on the MMI.

Zero current measurement

In power systems which are earthed to provide current limiting, the protection functions 'current comparison with current stabilization' and 'phase comparison' do not always guarantee a correct calculation. In such cases, the zero currents are used in the evaluation. Transmission faults during operation can cause a zero current to be simulated. Selectivity is ensured by a Fourier frequency analysis which supports the correct function of the zero current evaluation.

Breaker-failure protection

3

The breaker-failure protection function is integrated in the BU and incorporated as an option in the NBP. The fast-acting overcurrent functions monitor the phase currents independently and are equipped with two timers. The first time step operates as a stand-alone function in each BU, ie independently of the central unit.

The software logic in the BU is able to handle different breaker-failure configurations. For example, once the delay of the first timer has expired, a tripping command can be applied to a second tripping coil on the circuit-breaker. A transfer tripping signal is simultaneously transmitted to the station at the opposite end of the line. If the fault is still being measured at the end of the second time delay, the breaker-failure function uses the disconnector replica to trip all the other feeders in the same busbar section.

Each breaker has one BU allocated to it in which all the measurements and positions of that breaker are stored.

Overcurrent-time protection

This is a back-up protection function which is calculated locally in the BU and used to provide simple, autonomous feeder protection in each BU.

Event recording

All events are stored with a resolution of 1 ms in the central unit and in the BUs. System, protection and test events can be generated.

Protection events refer to the protected busbar and include the changes in the disconnecter and breaker positions, trips, etc. Test events are recorded during testing with the test signal generator. System events describe the diagnostic and fault messages of the NBP system as a whole.

Disturbance recorder function

The three conductor currents, the current in the directly earthed conductor, binary signals, and the voltages, can be recorded in each BU. Recording can be started, for example, by a protection function or an input signal. The disturbance recorder data are stored in the REB 500. They can be read out directly on the BU or at the central unit in COMTRADE format and stored on the PC. An evaluation program (eg, WINEVE) is used for further processing.

Communication

The numerical busbar protection is controlled by means of a modern, user-friendly operator interface. The man-machine communication takes place at three levels:

Local control

At this level, control takes place via the control unit incorporated in the BU or the central unit. This has LEDs for alarms, tripping commands and standby, an LCD display for the messages and for showing the measured values and statuses, and a small number of keys for entering data.

External MMI

A more comprehensive and convenient interface is provided at the second level by a personal computer **4** which is connected via a fiber-optic link to the central unit or the BU. With this PC, the operator can configure, parameterize and check the entire busbar protection system.

Station control

If the busbar protection has to be tied into a station control system (SCS) or station monitoring system (SMS), an optional communication module is added to the central unit. At this third communication level the MMI functions can be performed in the station control center.

Security concept

Self-supervision and diagnostics

To ensure maximum security and availability, all the protection functions are continuously supervised [2, 3]. Spurious tripping has to be avoided under all circumstances. In the case of a fault in the NBP, the system is blocked, an alarm is given and a diagnostic event is generated for analysis.

Important parts of the hardware, eg the processors, auxiliary supplies, A/D converters and memories, are tested in various ways when the system is being started and during operation. At the top of the hierarchy is the central unit master processor, at the bottom the inputs and outputs. Each diagnostic module continuously supervises the hardware on which it runs as well as the related application software and all diagnostic modules at the next lower level.

In the event of a critical fault, the entire system is blocked; when the fault is transient, the system is automatically de-blocked as soon as it is over.

The processing of the tripping commands is also important for the security and reliability. Control of the tripping relays has to be enabled periodically. Should this periodic function fail due to a fault in the software or hardware, all the tripping relays belonging to a particular zone are blocked and the failed function is signalled.

Availability

The use of tested and proven components is essential if high reliability is to

Bay unit of the REB 500 numerical busbar protection. Operation is via the built-in control unit or a personal computer. **4**



be ensured. The key advantage of a numerical protection system is its self-supervision capability, which allows all system faults to be immediately detected and, when necessary, the protection blocked [2].

Another advantage of numerical busbar protection is its modular design, which reduces the spare parts inventory to just a few types of module.

Nevertheless, individual component failure is possible over the long lifetime of the system. A back-up system therefore has to be available in case repairs become necessary. In the case of busbars, this is normally the distance protection in remote stations.

Security and stability

The security and stability of the numerical busbar protection are guaranteed by a range of measures corresponding to the different sources of failure which could be responsible for unselective or sudden tripping.

As mentioned, two independent protection algorithms provide higher se-

curity, since both have to come to the same conclusion (eg, an internal fault exists) in order for tripping to take place.

Most hardware and software failures are detected by the self-supervision function.

Attention also has to be given to the auxiliary contacts of the disconnectors. This requirement is well known from previous busbar protection systems. Supervision of each disconnector is an integral part of the busbar protection, and the disconnector replicas are realized without mechanical parts.

An additional logic is also available that eliminates the time-consuming adjustment of the auxiliary contacts of the disconnectors.

Testing

Each NBP system is fully tested in the factory in accordance with the busbar and NBP configuration specified by the customer. A new testing system has been developed for simulating the numerous operating situations of a versatile NBP

system and verifying the correct behaviour of the numerical algorithms.

REB 500 applications

Installation configurations

The flexibility of the system allows it to be used with a wide range of topologies. All configurations in medium-voltage, high-voltage and extra-high-voltage installations, from single busbar to complex quadruple busbar arrangements with transfer buses, can be protected.

Ring buses and 1½-breaker schemes can also be included in the protection concept.

Central installation

The centralized configuration is an especially interesting configuration for retrofit stations, since most of the existing connections to the bay can be re-used.

A central installation with a bay-oriented structure is shown in 5. As a special feature, the bay units are combined with line protection terminals, allowing intelligent interaction between two different types of protection.

The line protection is responsible for the main line, including the automatic reclosure, and has direct tripping outputs to the circuit-breaker. The BU incorporates, in addition to its busbar protection functions, the breaker-failure protection and also line back-up protection, such as overcurrent or overcurrent-time protection.

Other main differences between numerical busbar configurations and conventional installations are the former's fiber-optic cable connections between the feeder cubicles and the capability for connecting later extensions as 'distributed' installations.

Decentralized installation

This method of installation is today the state of the art in numerical protection technology. Bay units are positioned in

REB 500 protection system – centralized configuration with bay-oriented structure 5

- 1 Central unit
- 2 Bay unit and line protection
- 3 Fiber-optic links

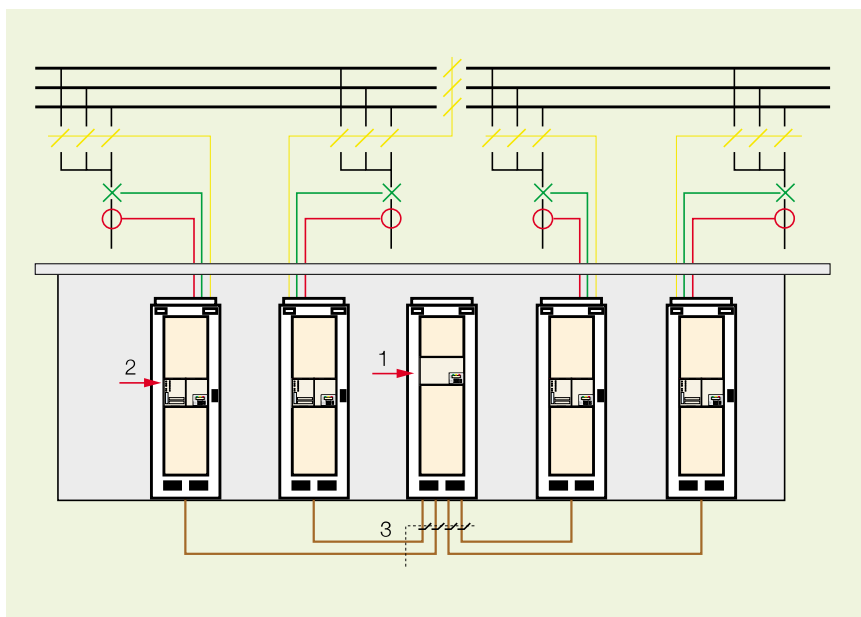

the field close to the switchgear and just a short distance away from the main current transformer, considerably reducing the wiring that is necessary. Each BU is connected to the central unit via a fiber-optic link, making it immune to electro-magnetic interference.

A distributed, feeder-oriented installation of this kind is shown in **6**. Such a configuration can be installed in existing stations on a bay-by-bay basis without having to take a busbar out of service.

1 1/2-circuit-breaker systems

An example of a configuration with a 1 1/2-breaker system is shown in **7**. Each breaker has a BU allocated to it in which all the measurements and the breaker positions are stored.

Operating experience

More than 90 percent of the NBP systems installed in new substations have a decentralized configuration, this also being the preferred arrangement for refurbishments.

Installations with the REB 500 numerical busbar protection have been in operation since January 1995 and are operating to the full satisfaction of the customers.

In two known cases, the NBP system remains stable and selective under extremely unfavourable conditions involving long-lasting external faults [4]. In one case, a single-pole fault in a 380-kV GIS station (at 1.8I_n) was isolated in just 26 ms.

High reliability

High reliability was ensured through a concept based on monitoring, fault diagnostics and fault detection.

Extensive testing during development, in the test bay and in the factory, as well as continuous self-supervision in operation, guarantees high reliability and security for the system.

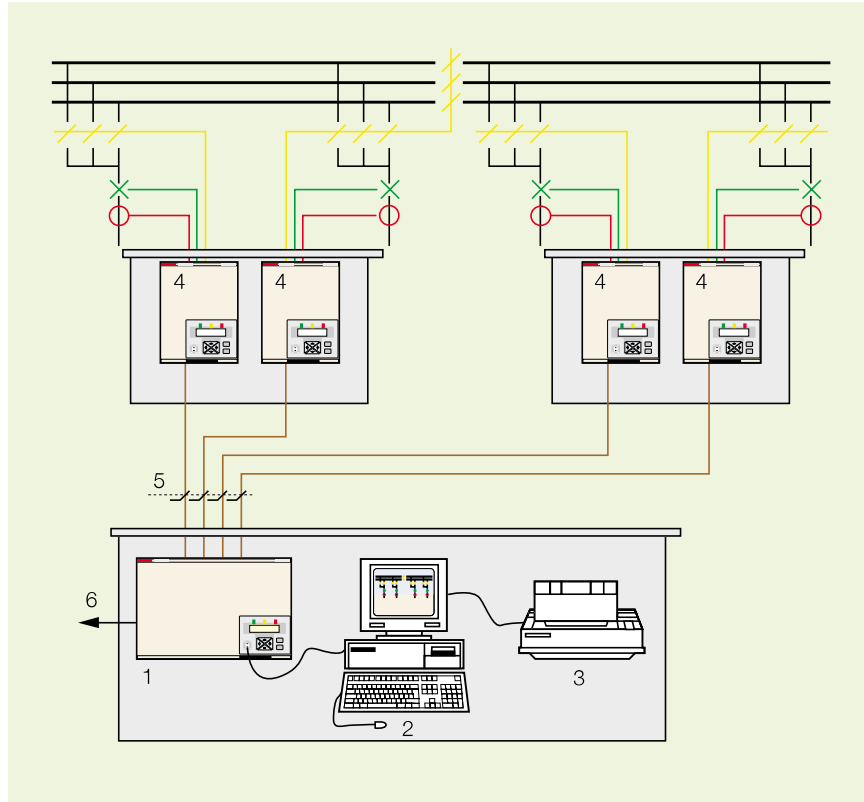

REB 500 protection system – decentralized, feeder-oriented configuration **6**

- 1 Central unit
- 2 Man-machine interface
- 3 Printer
- 4 Bay unit
- 5 Fiber-optic links
- 6 Link to station automation system

Structured methods and tools have been developed for the specification, design and implementation of the software. Careful attention was also given to the modularity of the system and the extension and potential for re-use of the system components. Together, this has led to an open, modular and versatile hardware and software platform with busbar protection as the first application.

Economic aspects

Low operating costs

The REB 500 numerical busbar protection is interesting both from a technical and economic standpoint, and its good market acceptance confirms the need for solutions of this kind. Comprehensive

self-supervision, integrated event and disturbance recorders, plus the possibility of tying the protection into a modern station control system, offer advantages that translate into economic, secure and reliable operation.

Reduced cabling

When conventional busbar protection is installed, large numbers of copper wires and cable are required to connect the system to the switchgear. The cross-sectional area of the cable, especially in the case of the current transformers, can be up to 16 mm², depending on the distance involved. Such cabling is not only costly; the time taking to install it is also time-consuming.

It is in this area that the advantages of the distributed configuration of the REB

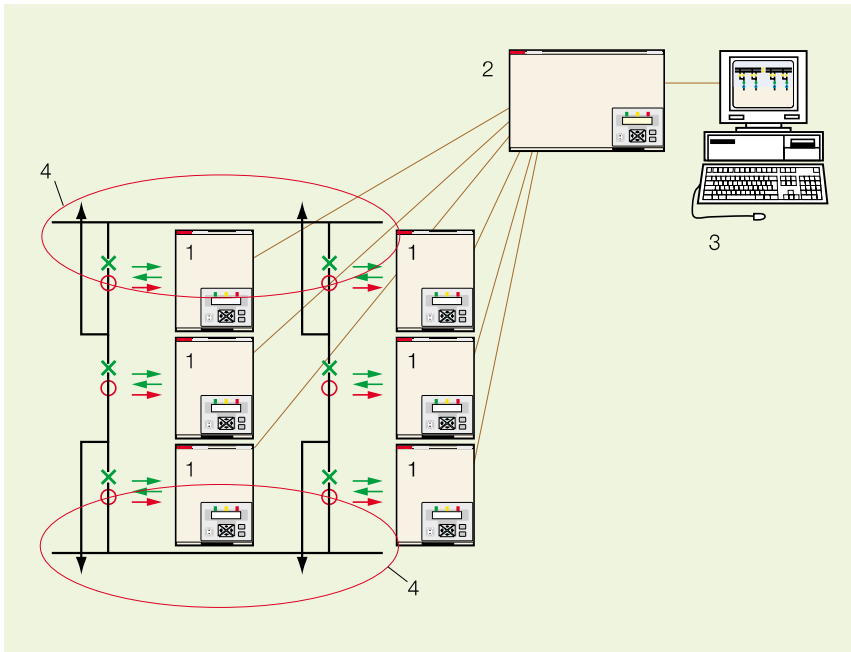

1 1/2-breaker system with busbar, breaker-failure and overcurrent-time protection

7

- 1 Bay unit
- 2 Central unit
- 3 Station automation system
- 4 Busbar protection zones

500 come to the fore. By installing the BUs close to the switchbays, the length of the copper wire and cable can be reduced to just a few meters, which allows a corresponding reduction in cross-section.

Only two fiber-optic cables are needed to connect a bay unit to the central unit. Multicore fiber-optic cable can be used if it is desired to transmit further digital signals, for example for measurements. This allows a considerable reduction in the overall cost of a distributed busbar protection system.

Summary

A numerical system can be installed in substations with far less hardware and wiring than when conventional systems are used. The functionality is defined by the software, which can be configured with the help of specially developed tools and the man-machine interface. The total time needed to realize a project is sub-

stantially shorter than with conventional systems.

The use of a small number of fiber-optic links in place of conventional wiring has opened the door to new installation philosophies. With the development of new sensor technologies, etc, additional reductions in the cost of the overall installations can be expected.

References

- [1] D. M. Peck, B. Nygaard, K. Wade-lius: A new numerical busbar protection system with bay-oriented structure. IEE Fifth International Conference on Developments in Power System Protection, University of York, UK, March 1993.
- [2] B. Eschermann, P. Terwiesch, K. Scherer: Continuous self-supervision enhances reliability of HV substation protection. ABB Review 2/1996, 18–24.
- [3] J. Bertsch, K. Feser, W. Fromm, M. Gasparini: New algorithms for a numerical busbar protection system. IEEE/KTH

Stockholm Power Tech. Conference, June 18–22, 1995.

[4] M. Ilar: Decentralized numerical busbar and breaker-failure protection. IEEE Conference, November 1996, Monterrey, Mexico.

[5] F. Ilar, B. Nygaard: Numerical busbar protection with distributed functionality, New Concept in Power System Control, MIPRO 95, Opatija/Croatia.

[6] B. Sander, S. Läderach, H. Ungrad, F. Ilar, I. de Mesmaeker: Adaptive protection based on interaction between protection and control. CIGRE, Session 1994, Paris, Rep. 34–205.

Authors' address

Majda Ilar
 Beat Reimann
 Dieter Brunner
 ABB Network Partner AG
 CH-5401 Baden
 Switzerland
 Telefax: +41 56 205 5112
 E-mail:
 dieter.brunner@chnet.mail.abb.com