



## Safety Manager Release 162



## Hardware Reference

EP-SM.MAN.6284

Issue 2.1 | December 2023

- Original Instructions -

## 5 Chassis

### 5.2 CPCHAS-0001

---

## 5.2 CPCHAS-0001

Chassis for redundant or non-redundant Controller (Safety Manager)

### 5.2.1 General

The Controller chassis CPCHAS-0001 is used to contain the Control Processor modules. Each Safety Manager has one Controller chassis. The Controller chassis is generally located at the top position in the cabinet, and the IO chassis at lower positions.

A Controller chassis contains the following components:

- Controller housing
- Controller backplane

### 5.2.2 Controller housing

The Controller housing has been designed specifically for Safety Manager. It is a 19" housing that is open at the front and covered at the back.

Control Processor modules are placed in the chassis through the front of the housing with the use of module guides, which are located at the bottom and top plate of the housing.

The modules are locked in the chassis with the quarter turn fasteners, located below the module-grips.

The below figure shows the front of a filled redundant Controller chassis.

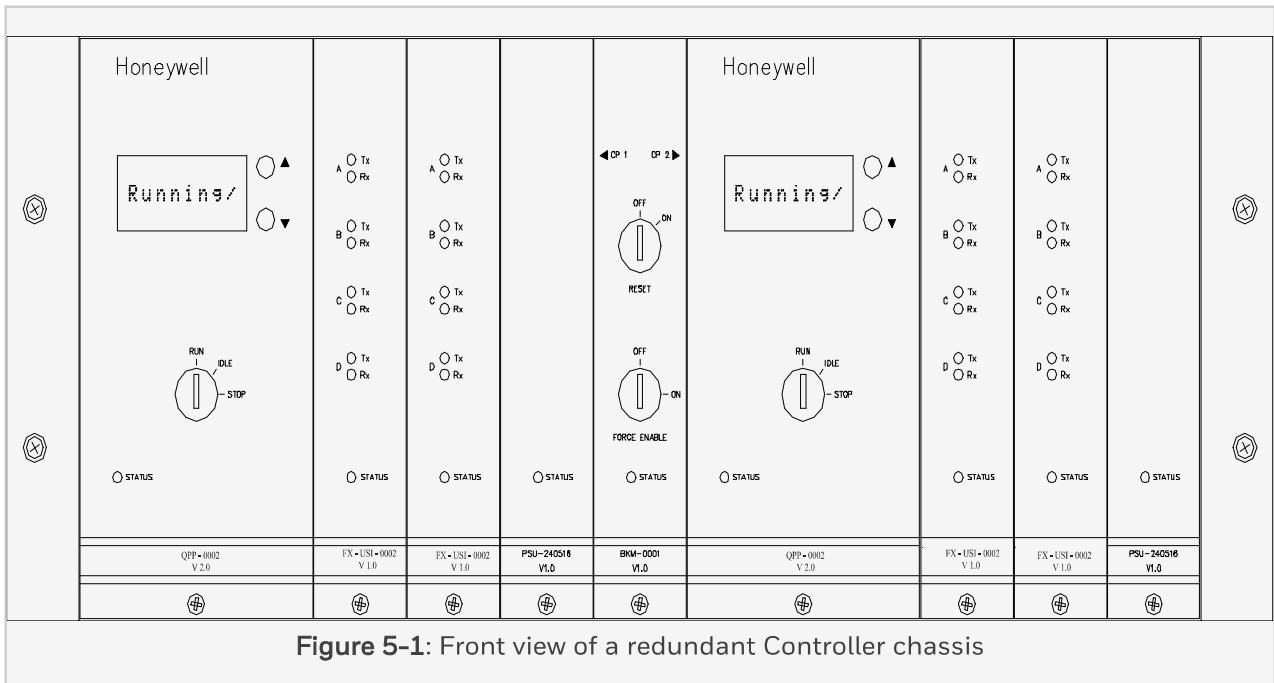

Figure 5-1: Front view of a redundant Controller chassis

The below figure shows the front of a filled non-redundant Controller chassis.

5 Chassis

5.2 CPCHAS-0001

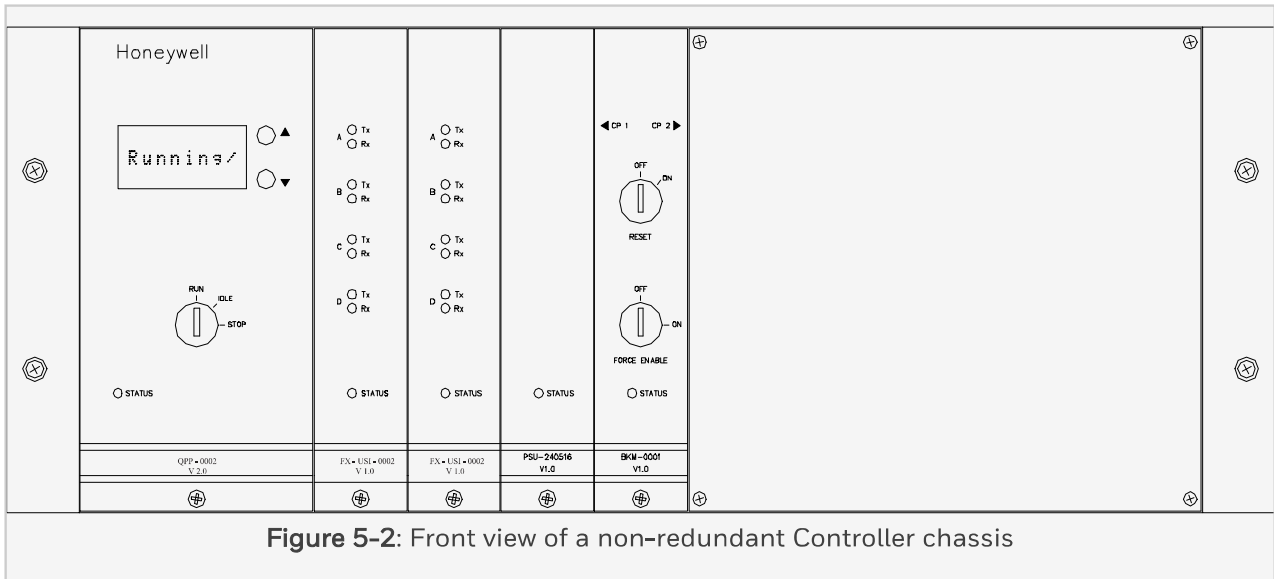

Figure 5-2: Front view of a non-redundant Controller chassis

The back of the housing is covered by a magnetically locked back cover plate, which can be swung upwards to reveal the Controller backplane.

Cables must be tie-wrapped to one of the three horizontal bars at the back of the housing, to lead them towards the side of the chassis.

The top bar is reserved for the 24V-supply and 24V-signal wires/cables.

The middle bar is reserved for the communication cables.

The bottom bar is reserved for the 5V and Watchdog cables (WdPx and 5V-x).

The below figure shows the back of an empty Controller chassis.

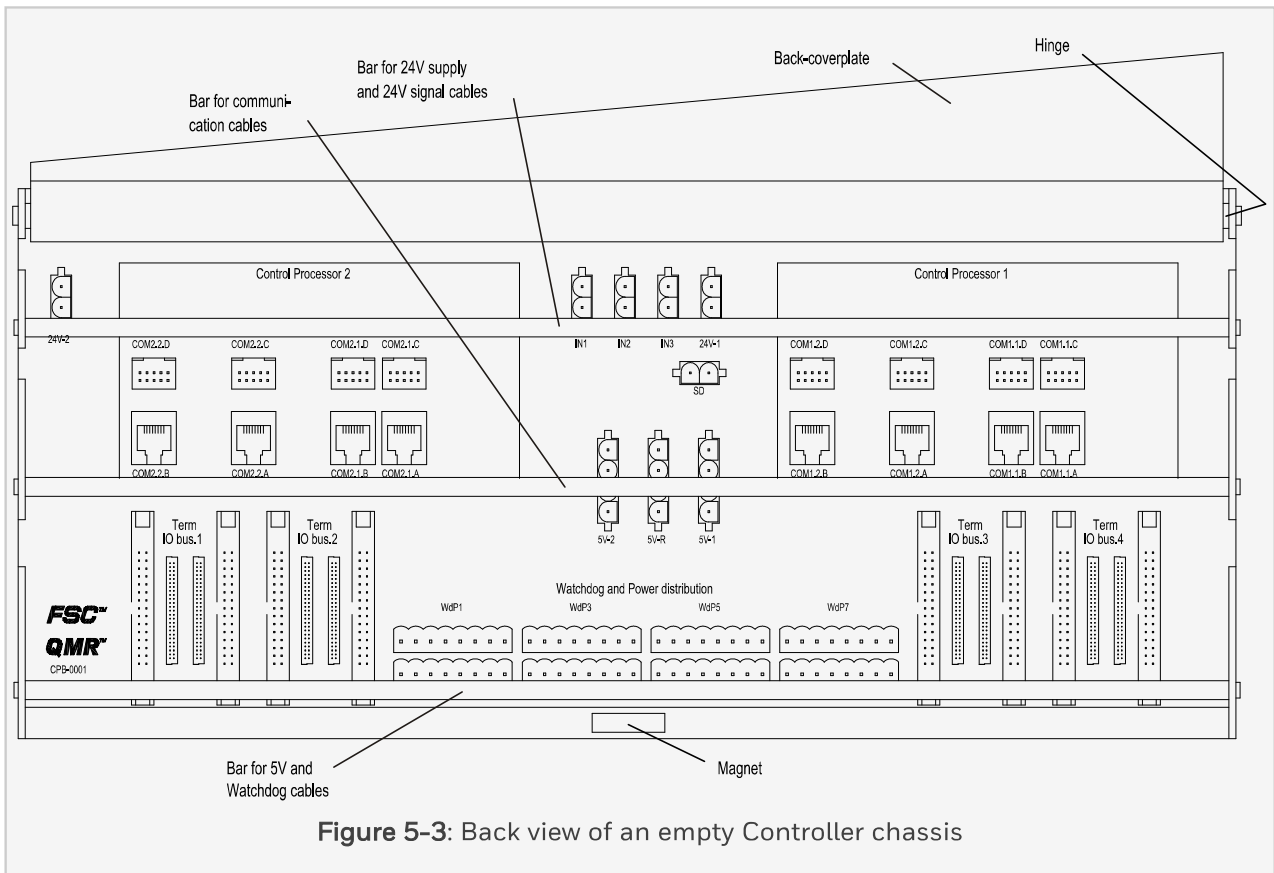

Figure 5-3: Back view of an empty Controller chassis

### 5.2.3 Location of Control Processor modules

The Controller chassis CPCHAS-0001 contains all Control Processor modules.

The below table shows the location of the Control Processor modules in a non-redundant and a redundant Controller (as seen from the front of the cabinet). As you can see, all Control Processor modules are doubled in a redundant Controller configuration, with the exception of the Battery and Key switch module, which is shared by both Control Processors.

5 Chassis

5.2 CPCHAS-0001

***Distribution of the various Control Processor modules in the Controller chassis***

Redundant Controller								
Non-Redundant Controller								
CPU 1	COM 1.1	COM 1.2	PSU 1	BKM	CPU 2	COM 2.1	C.O.M.2.2	PSU 2
Legend:								
Item	Description						See	
CPU1	the processor module of the first Control Processor							
	QPP-0002 Quad Processor Pack						QPP-0002	
COM1.1	the first communication module of the first Control Processor							
	USI-0002 Universal Safety Interface, or						FX-USI-0002	
	BLIND-COM Dummy Communication Module						BLIND-COM	
COM1.2	the second communication module of the first Control Processor							
	USI-0002 Universal Safety Interface, or						FX-USI-0002	
	BLIND-COM Dummy Communication Module						BLIND-COM	
PSU1	the power supply module of the first Control Processor							
	PSU-240516 Power Supply Unit 24/5 V DC, 16A						PSU-240516	
BKM	the battery and key switch module of (both) Control Processor(s)							
	BKM-0001 Battery and Key switch Module						BKM-0001	
CPU2	the processor module of the first Control Processor							
	QPP-0002 Quad Processor Pack						QPP-0002	

Redundant Controller		
Non-Redundant Controller		
COM2.1	the first communication module of the second Control Processor	
	USI-0002 Universal Safety Interface, or	FX-USI-0002
	BLIND-COM Dummy Communication Module	BLIND-COM
COM2.2	the second communication module of the second Control Processor	
	USI-0002 Universal Safety Interface, or	FX-USI-0002
	BLIND-COM Dummy Communication Module	BLIND-COM
PSU2	the power supply module of the second Control Processor	
	PSU-240516 Power Supply Unit 24/5 V DC, 16A	PSU-240516

In case of a non-redundant Controller, the unused positions in the Controller chassis (CPU2, COM2.1, COM2.2, and PSU2) are covered by an BLIND-CPS plate (see Figure 6-2).

For each Quad Processor Pack, room is provided for two communication modules in the Controller chassis. The below table shows possible locations for different combinations of communication modules.

**Note:**

If only one communication module is used in a Control Processor, the module is placed in the COM1 slot (see the below table). A blind communication module (BLIND-COM) should be placed in all unused communication slots.

**Possible locations of communication modules in the Controller chassis**

Number of modules	COM1 Slot	COM2 Slot
0	BLIND-COM	BLIND-COM
1	USI-0002	BLIND-COM
2	USI-0002	USI-0002

5 Chassis

5.2 CPCHAS-0001

**5.2.4 Controller backplane**

The Controller backplane is part of the Controller chassis. The front side contains the connectors for the Control Processor modules. The keying pins in the backplane connect the module housings with ground.

The below figure shows the front view of an empty redundant Controller chassis, showing the Controller backplane.

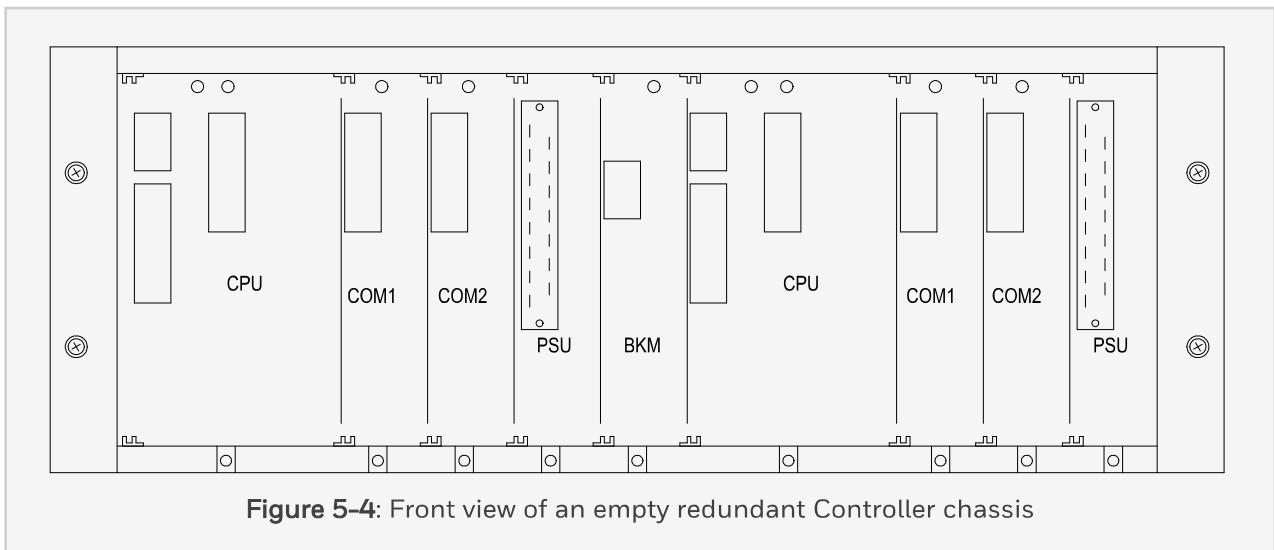

The back side of the Controller backplane contains all the connectors for signals that go in or out of the (non-)redundant Controller. These connectors are visible when the back cover plate is swung upwards (see Figure 3).

The Controller backplane connects the 5VR output of the PSU of CP1 with the 5VR output of the PSU of CP2.

The resulting 5V-R is used to supply the non-redundant IO.

Thanks to the output diodes in the PSU-240516 (see Figure 2) the 5V-R will be available as long as (at least) one of the PSUs is operating.

The figure on the next page shows the 5V connection of the two PSU-240516 modules on the Controller backplane.

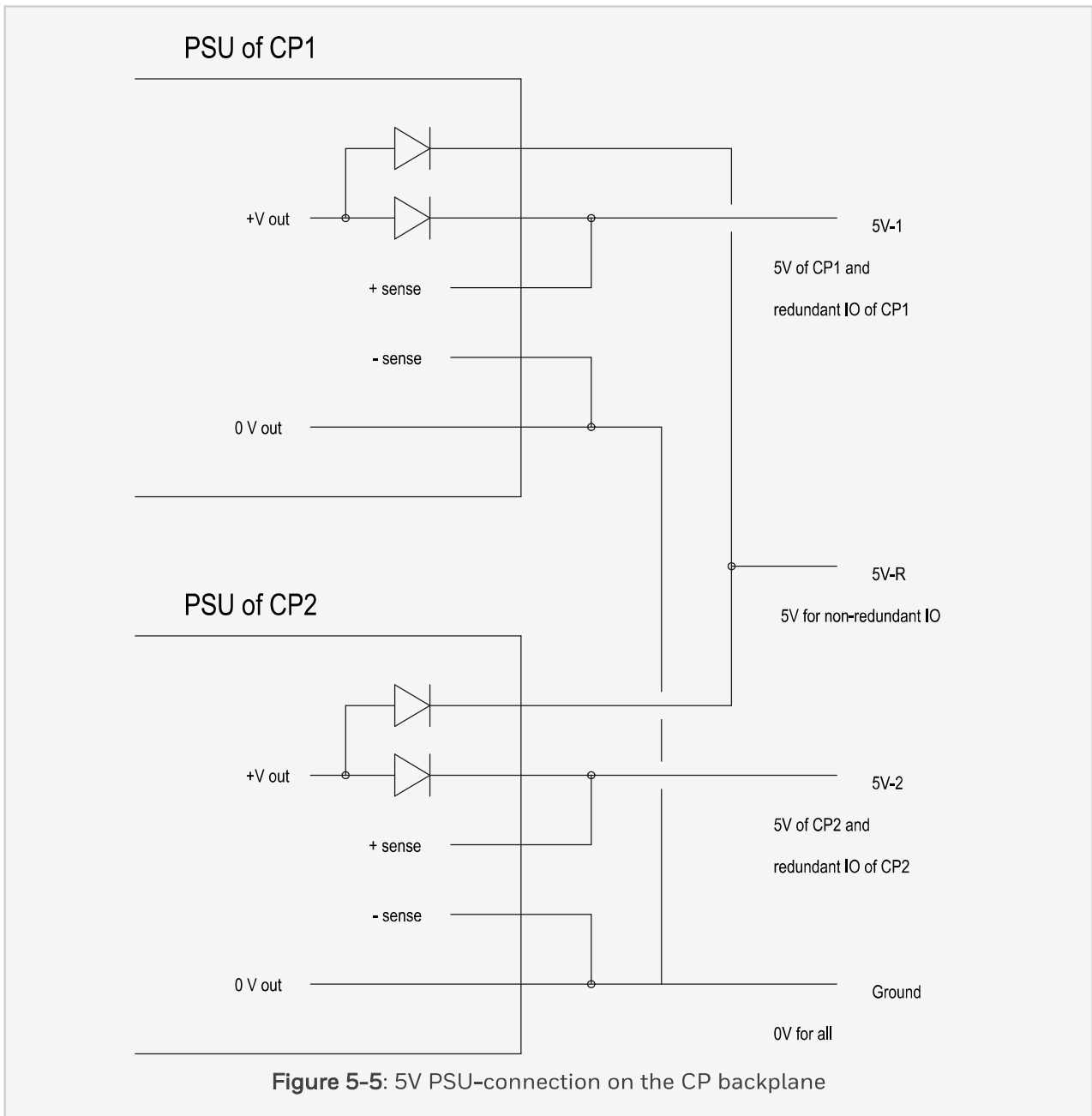

5 Chassis

5.2 CPCHAS-0001

5.2.4.1 Pin allocation

The back view and pin allocation of the 24V-1 and 24V-2 connectors are:

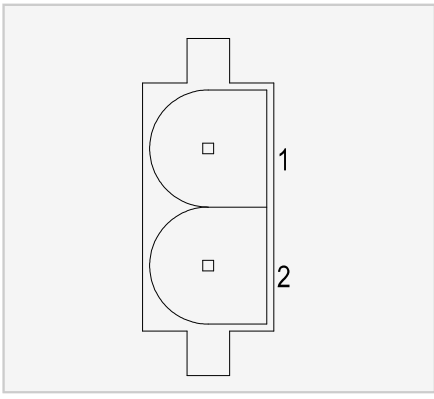
		24V-1	24V-2
	1	+24V for CP1	+24V for CP2
	2	0V for CP1	0V for CP2

The back view and pin allocation of the IN1, IN2 and IN3 connectors are:

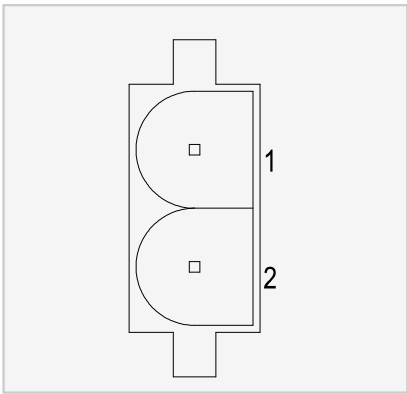
		IN1	IN2	IN3
	1	+24V_red	+24V_red	+24V_red
	2	input1	input2	input3

The back view and pin allocation of the SD connector is:

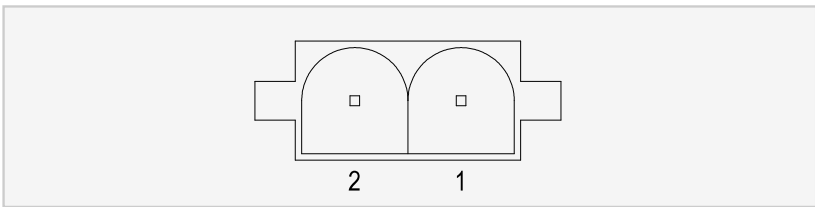
		SD
	1	+24V_sd
	2	input

The back view and pin allocation of the 5V-2, 5V-R and 5V-1 connectors are:

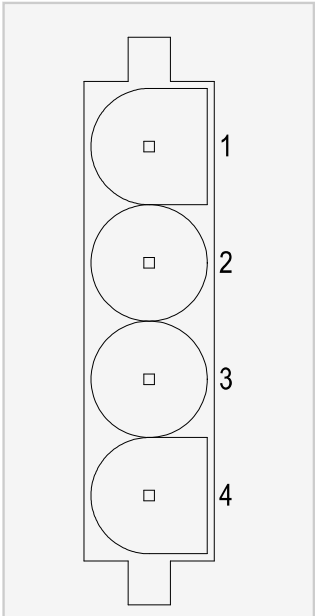
		5V-2	5V-R	
	1	ground	ground	ground
	2	WD of CP2	WDR of CP1 and CP2	WD of CP1
	3	ground	ground	ground
	4	5V of CP2	5VR of CP1 and CP2	5V of CP1

The back view and pin allocation of the eight WdPx connectors are:

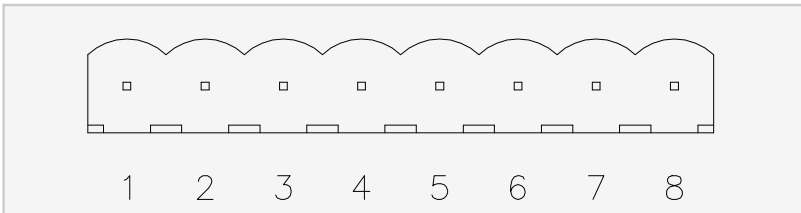
		WdPx
	1	5V of CP2
	2	WD of CP2
	3	ground
	4	5VR of CP1 and CP2
	5	WDR of CP1 and CP2
	6	ground
	7	5V of CP1
8	WD of CP1	

5 Chassis

5.2 CPCHAS-0001

5.2.4.2 Connector function

The table on the next page describes the function of the connectors on the back side of the Controller backplane.

**Connectors at the back side of the Controller backplane**

Group	Name	Connector type	Used for
Control Processor 1	Com1.1.A	RJ45	Ethernet communication channels 1 and 2 of the communication module in the COM1 location
	Com1.1.B	RJ45	
	Com1.1.C	10-pin male	General purpose communication channels 3 and 4 of the communication module in the COM1 location
	Com1.1.D	10-pin male	
	Com1.2.A	RJ45	Ethernet communication channels 1 and 2 of the communication module in the COM2 location
	Com1.2.B	RJ45	
	Com1.2.C	10-pin male	General purpose communication channels 3 and 4 of the communication module in the COM2 location
	Com1.2.D	10-pin male	
Control Processor 2	Com2.1.A	RJ45	Ethernet communication channels 1 and 2 of the communication module in the COM1 location
	Com2.1.B	RJ45	
	Com2.1.C	10-pin male	General purpose communication channels 3 and 4 of the communication module in the COM1 location
	Com2.1.D	10-pin male	
	Com2.2.A	RJ45	Ethernet communication channels 1 and 2 of the communication module in the COM2 location
	Com2.2.B	RJ45	
	Com2.2.C	10-pin male	General purpose communication channels 3 and 4 of the communication module in the COM2 location
	Com2.2.D	10-pin male	

Group	Name	Connector type	Used for
IO bus 1	IO bus1.1	Flat cable connector	first IO bus of Control Processor 1
	IO bus2.1	Flat cable connector	first IO bus of Control Processor 2
	Term IO bus1	2 × 50-pin connector	IO bus terminator for the first IO bus(es) Type: TERM-0001 or TERM-0002, TERM-0001 and TERM-0002 for details.
IO bus 2	IO bus1.2	Flat cable connector	second IO bus of Control Processor 1
	IO bus2.2	Flat cable connector	second IO bus of Control Processor 2
	Term IO bus2	2 × 50-pin connector	IO bus terminator for the second IO bus(es) Type: TERM-0001 or TERM-0002, TERM-0001 and TERM-0002 for details.
IO bus 3	IO bus1.3	Flat cable connector	third IO bus of Control Processor 1
	IO bus2.3	Flat cable connector	third IO bus of Control Processor 2
	Term IO bus3	2 × 50-pin connector	IO bus terminator for the third IO bus(es) Type: TERM-0001 or TERM-0002, TERM-0001 and TERM-0002 for details.
IO bus 4	IO bus1.4	Flat cable connector	fourth IO bus of Control Processor 1
	IO bus2.4	Flat cable connector	fourth IO bus of Control Processor 2
	Term IO bus4	2 × 50-pin connector	IO bus terminator for the fourth IO bus(es) Type: TERM-0001 or TERM-0002, TERM-0001 and TERM-0002 for details.
Watchdog	WdP1	8-pin male	Watchdog and Power to IO chassis 12

5 Chassis

5.2 CPCHAS-0001

Group	Name	Connector type	Used for
and Power <sup>1</sup> distribution		connector	
	WdP2	8-pin male connector	Watchdog and Power to IO chassis 2
	WdP3	8-pin male connector	Watchdog and Power to IO chassis 3
	WdP4	8-pin male connector	Watchdog and Power to IO chassis 4
	WdP5	8-pin male connector	Watchdog and Power to IO chassis 5
	WdP6	8-pin male connector	Watchdog and Power to IO chassis 6
	WdP7	8-pin male connector	Watchdog and Power to IO chassis 7
	WdP8	8-pin male connector	Watchdog and Power to IO chassis 8
Power	24V-1	2-pin male connector	24V for Control Processor 1 (for cable details see PDC-CP24).
	24V-2	2-pin male connector	24V for Control Processor 2 (for cable details see PDC-CP24).
	5V-1	4-pin male connector	5V and Watchdog of Control Processor 1. This connector is used to distribute these signals to other (extension) cabinets using an PDB-IOX05 (for more information see PDB-IOX05).
	5V-2	4-pin male connector	5V and Watchdog of Control Processor 2. This connector is used to distribute these signals to other (extension) cabinets using an PDB-IOX05 (for more information see PDB-IOX05).

Group	Name	Connector type	Used for
	5V-R	4-pin male connector	Redundant 5V and redundant Watchdog. This connector is used to distribute these signals to other (extension) cabinets using an PDB-IOX05 (for more information see PDB-IOX05).
Various	SD	2-pin male connector	Connector for an Emergency Shut Down system. The chassis is delivered with the LINK-SD link placed. This link is required if the Emergency Shut Down function is not used (see also QPP data sheets QPP-0002 and SICP-0002/L3).
	IN1	2-pin male connector	24 Volt non-safety related general purpose input. This input can generate an interrupt (on the rising edge) e.g. for external clock synchronization (see also BKM-0001 and SICP-0002/L3).
	IN2	2-pin male connector	24 Volt non-safety related general purpose input (see also BKM-0001 and SICP-0002/L3).
	IN3	2-pin male connector	24 Volt non-safety related general purpose input (see also BKM-0001 and SICP-0002/L3).
<ol style="list-style-type: none"> <li>1. Watchdog and 5 Volt of Control Processor 1, Control Processor 2 and the redundant Watchdog and 5 Volt.</li> <li>2. The chassis numbers mentioned here are defined by jumpers on the IO backplane.</li> </ol>			

5 Chassis

5.2 CPCHAS-0001

---

5.2.5 Technical data

General	Type number <sup>1</sup> :	FS-CPCHAS-0001
	Approvals:	CE, UL, CSA, TUV, FM
Power consumption	5V-1:	0.05 A
	5V-2:	0.05 A
Dimensions	Height:	4 HE (177 mm, 7 in)
	Width:	482.6 mm, 19 in
	Depth:	280 mm, 11 in
	Weight:	5.8 kg, 12.8 lb

**Note:**

1. Chassis with suffix code V1.1 and higher have an improved cover plate design and reduced power consumption. (Chassis with suffix code V1.0 consume 0.5A per feeder.)

There are no functional changes.