

3.1 Plug-in base ECZ

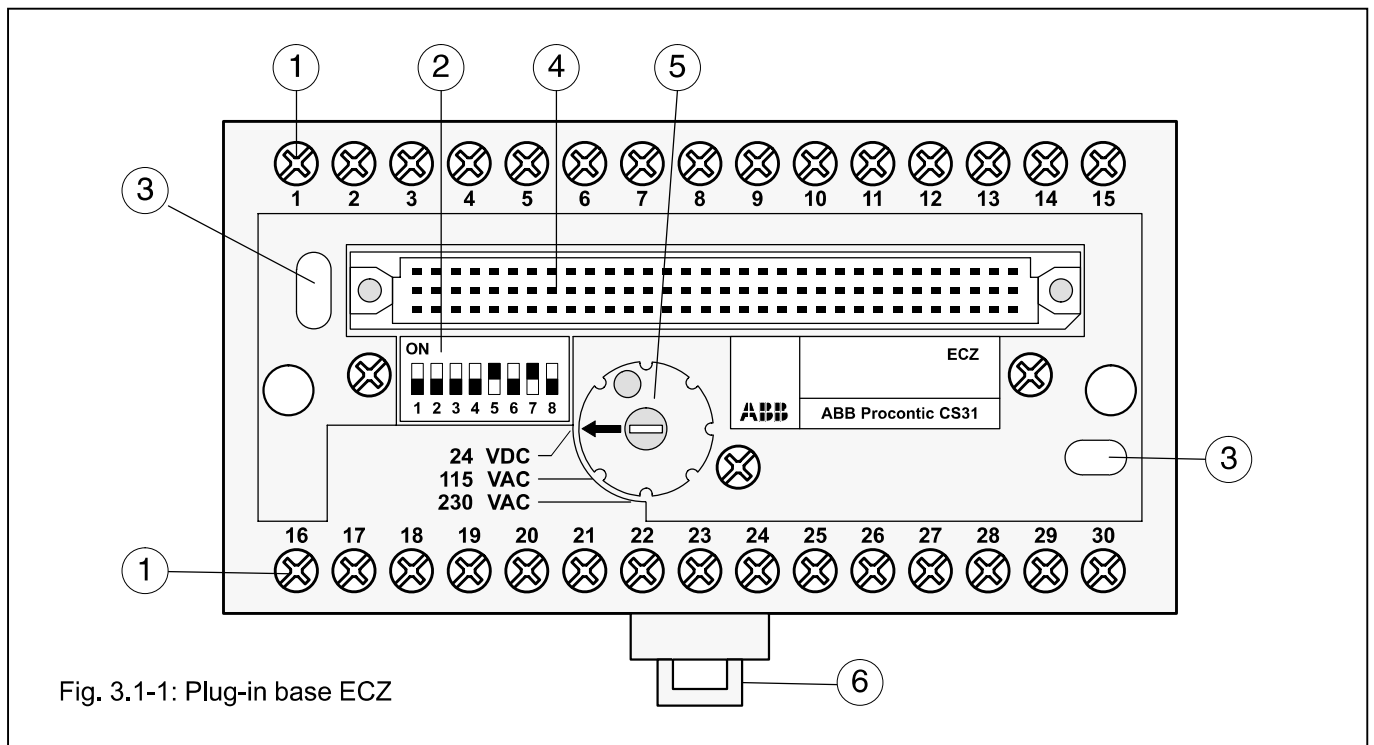

Fig. 3.1-1: Plug-in base ECZ

- (1) Terminals (1-30)
- (2) DIL switch for setting the module address
- (3) Two bore holes for mounting on a surface
- (4) DIN plug (96-pole) for the electrical connection with the remote modules
- (5) Rotary wheel for mechanical coding of the supply voltage (24 V DC, 115 V AC, 230 V AC). Prevents that a module can be plugged-in with another supply voltage than set on the ECZ.
- (6) Adaptor for mounting the plug-in base onto a DIN rail.

The plug-in base ECZ is used for CS31 remote modules as well as for the basic units PCZB and CS20. For the digital input module ICSI 16 L1, two plug-in bases are necessary.

The remote modules are put on the plug-in base and then fastened with two screws. The screws belong to the remote modules. They can be reached from the front panel.

The electric wiring is performed via the terminals 1 to 30 of the plug-in base. In this way, remote modules can be replaced without loosening wires.

3.1.1 Technical data

Terminals
Weight
Order No.

Independent of which type of module is mounted, the terminals 1, 2, 3, 16, 17 and 18 always have the same allocation:

Terminal 1: Bus 2
Terminal 2: Bus 1
Terminal 3: Shield (system bus)
Terminal 16: Supply voltage +24 V DC or 230 V AC
Terminal 17: Supply voltage 0 V or AC
Terminal 18: Earthing

In order to protect the remote modules from electrical interferences, the terminals for the supply voltage are equipped with a filter circuitry. The components (L, C) are integrated in the plug-in base.

The assignment of the other terminals depends on the module type put on the plug-in base (see module descriptions).

Remote modules can be replaced without switching off the power supply.

Wiring of the 2-wire bus: All terminals No. 2 (BUS 1) of the plug-in bases have to be connected with the BUS1 terminal of the basic unit. All terminals No. 1 (BUS2) of the plug-in bases have to be connected with the BUS2 terminal of the basic unit.

conductor cross section max. 2 x 2.5 mm²
200 g
FPR3700001R0001

4.2 Digital input module ICSI 08 E4

8 input channels 230 V AC, electrically isolated
CS31 system bus interface electrically isolated

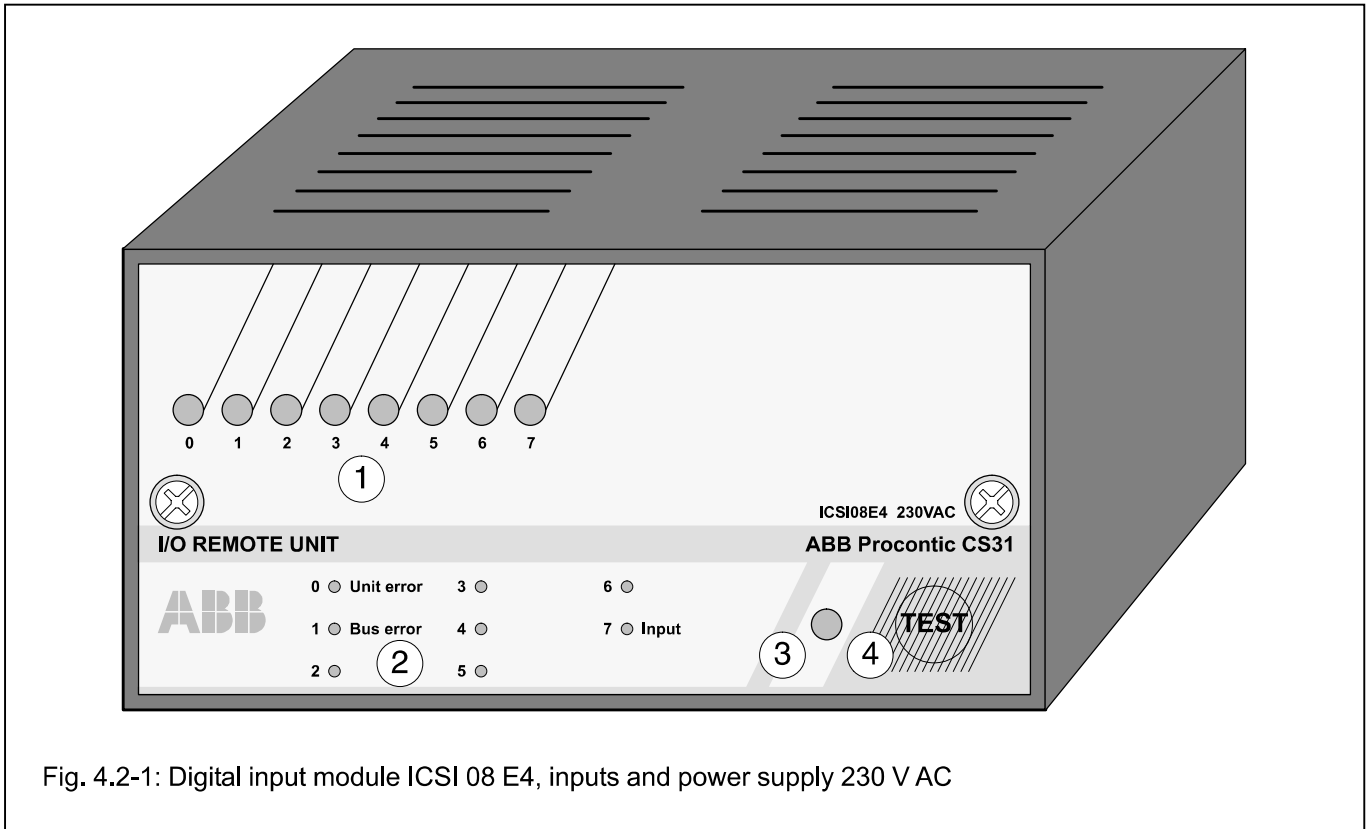

Fig. 4.2-1: Digital input module ICSI 08 E4, inputs and power supply 230 V AC

Contents

Intended purpose	4.2-1
Display and operating elements on the front panel	4.2-1
Electrical connection	4.2-1
Addressing	4.2-3
I/O configuration	4.2-3
Normal operation	4.2-3
Diagnosis and displays	4.2-3
Technical data	4.2-4
Dimensions for installation	4.2-5

Intended purpose

The digital input module ICSI 08 E4 is used as a remote module on the CS31 system bus. It contains 8 **electrically isolated** input channels for a rated voltage of 230 V AC. The signal statuses of the input signals is indicated with 8 yellow LEDs on the front panel.

The module is powered by a supply voltage of 230 V AC. It is electrically isolated from the mains voltage. For electrical connection, it has to be mounted on a plug-in base ECZ.

The CS31 system bus interface is electrically isolated from the rest of the module.

The module offers a number of diagnosis functions (see chapter "Diagnosis and displays").

Display and operating elements on the front panel

- ① 8 yellow LEDs to indicate the signal status of the inputs or for displaying error and diagnosis data
- ② List of diagnosis information concerning the LEDs when they are used for diagnosis display
- ③ Red LED for error message
- ④ Test button

Electrical connection

The module has to be mounted on the plug-in base ECZ and then fastened with two screws. The plug-in base has a mechanical coding which prevents that a module can be plugged-in with another supply voltage than set on the ECZ. Before mounting the input module, the mechanical coding has to be set to the correct supply voltage.

The following figure shows the electrical connection of the input module.

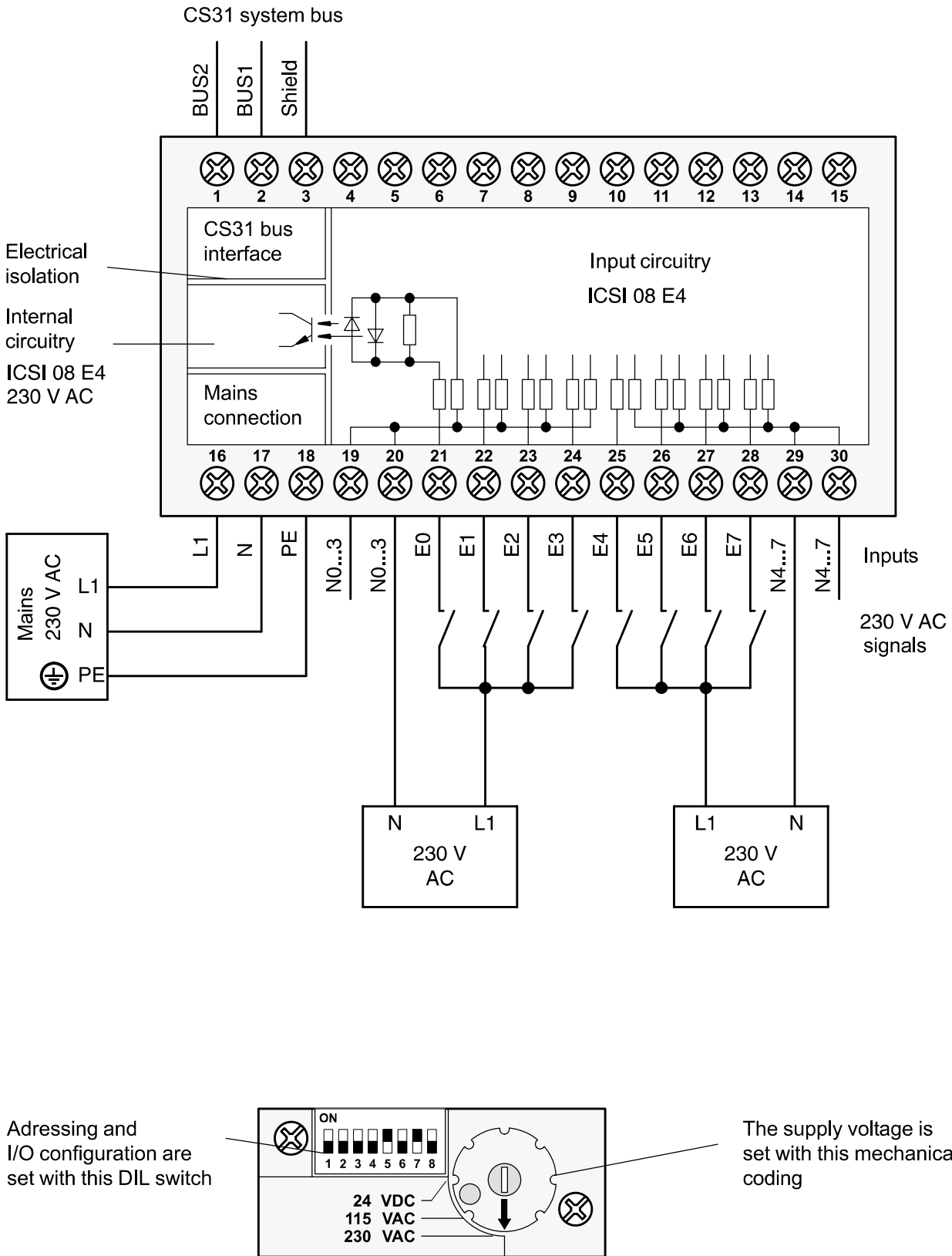

Fig. 4.2-2: Electrical connection of the digital input module ICSI 08 E4, supply voltage 230 V AC

Addressing

An address must be set for each module to enable the basic unit to correctly access the inputs.

A detailed description about "Addressing" can be found in the chapter "Addressing" of the basic units and couplers.

The address setting is accomplished with the DIL switch on the plug-in base ECZ. When using the basic units 07 KR 91 and 07 KT 9x as bus masters, the following address assignments are valid:

Basic unit	07 KR 91 / 07 KT 9x	
DIL switch No. 8 on the ECZ	OFF (recommended)	ON
Channel		
E0	E xx,00	E xx,08
E1	E xx,01	E xx,09
E2	E xx,02	E xx,10
E3	E xx,03	E xx,11
E4	E xx,04	E xx,12
E5	E xx,05	E xx,13
E6	E xx,06	E xx,14
E7	E xx,07	E xx,15
xx: Group number of the address, set on the DIL switch of the plug-in base with the switches 2...7. Recommended addresses with 07 KR 91 / 07 KT 9x as bus masters: 08, 10, 12...60 (even-numbered addresses)		

The module uses 8 inputs on the CS31 system bus.

I/O configuration

An I/O configuration is only necessary, if the application needs other settings than the factory settings.

The following functions can be configured:

- Alteration of the input signal delay

As factory setting both the ON delay and the OFF delay of the inputs are 10 ms. A change to values of 2...32 ms is possible via the CS31 system bus. After setting via the system bus, the real delay is 10 ms longer than the set value.

I/O configuration data, which was set via the CS31 system bus, are stored in the module even after power OFF/ON.

Using the test button, the set configuration of all channels can be individually interrogated (see chapter "Diagnosis and displays").

For detailed descriptions about methodology of the I/O configuration via the CS31 system bus see the chapters "I/O configuration" of the used basic units and couplers.

Normal operation

- After power ON the module initializes automatically. During this period the red LED (3) flashes.
- After initialization the red LED (3) goes out, if the bus runs correctly and if the module has detected no error.
- The 8 yellow LEDs (1) indicate the signal statuses of the channels E0...E7.

Diagnosis and displays

Diagnosis functions:

- Error inside the module
- Error on the CS31 system bus

If one of these errors occurs, the red LED (3) lights up.

Using the test button (4) and the LEDs (1), diagnosis information can be achieved directly at the module.

By pressing the test button the first time, the channel **E0** is selected: LED0 flashes. After releasing the test button, the diagnosis information of this channel is displayed with the 8 yellow LEDs for a period of ca. 3 seconds.

The ON status of the LEDs means:

- 0 Error inside the module (Unit error)
- 1 Error on the CS31 system bus (Bus error)
- 2 not used
- 3 not used
- 4 not used
- 5 not used
- 6 not used
- 7 Configuration as an input (Input)

The meaning of the LEDs (2) is also printed on the front panel of the module in English.

With every further pushing and releasing the test button, the described procedure repeats for the other channels.

After calling up the last channel (E7), a lamp test (LED test) is performed when the test button is pushed again. All 8 LEDs must light up.

After releasing the test button, the 8 LEDs show the setting of the DIL switches of the plug-in base for a period of ca. 5 seconds. LED0 shows switch 1 (LEDs 0...7 belong to the switches 1...8).

All error messages are stored in the module. They can be deleted in the following ways:

- by pressing the test button for about 10 seconds or
- with power OFF/ON or
- via the CS31 system bus.

Diagnosis data, which can be evaluated, are also sent to the basic units and couplers which work as the bus master.

For further details see the chapter "Diagnosis" in the description of the basic units and couplers.

After finishing the diagnosis procedure, the 8 LEDs again show the signal statuses of the channels. The same is valid for the pauses between the steps of the procedure.

Technical data

General data of the module

Versions	R 0016
Rated power supply voltage	230 V AC, 50 or 60 Hz
Max. input power	5 VA
Max. power dissipation in the module	6 W
Max. conductor cross section of the terminals (flexible lead with wire end ferrule)	2 cores of 2.5 mm ² per terminal
Weight	plug-in base ECZ 200 g module ICSI 08 E4 430 g

Technical data of the inputs

Number of inputs per module	8
Arrangement of the inputs	in 2 groups of 4 channels each, each group has its own reference potential
Electrical isolation	yes, between the groups and from the rest of the module
Electrical isolation from the mains voltage	yes
Signal levels of the inputs:	
Rated voltage	230 V AC, 50 or 60 Hz
Signal 0	0...40 V AC
Signal 1	159...253 V AC
Supply current at 230 V AC	ca. 6.5 mA
Input signal delay	
transition 0 → 1 or 1 → 0	2 to 32 ms configurable, standard setting is 10 ms. After setting via the system bus, the real delay is 10 ms longer than the set value.
Signalling	1 yellow LED per channel

Mechanical data

Installation methods	on a DIN rail or fastening by screws
Mounting depth including the plug-in base and a flat DIN rail	117 mm
Dimensions of the plug-in base (see the drawing below)	
snapping onto the DIN rail	centrally between top and bottom of the plug-in base
fastening by M4 screws	102 mm x 22 mm
max. outline dimensions of the plug-in base	124 mm x 64 (+12) mm

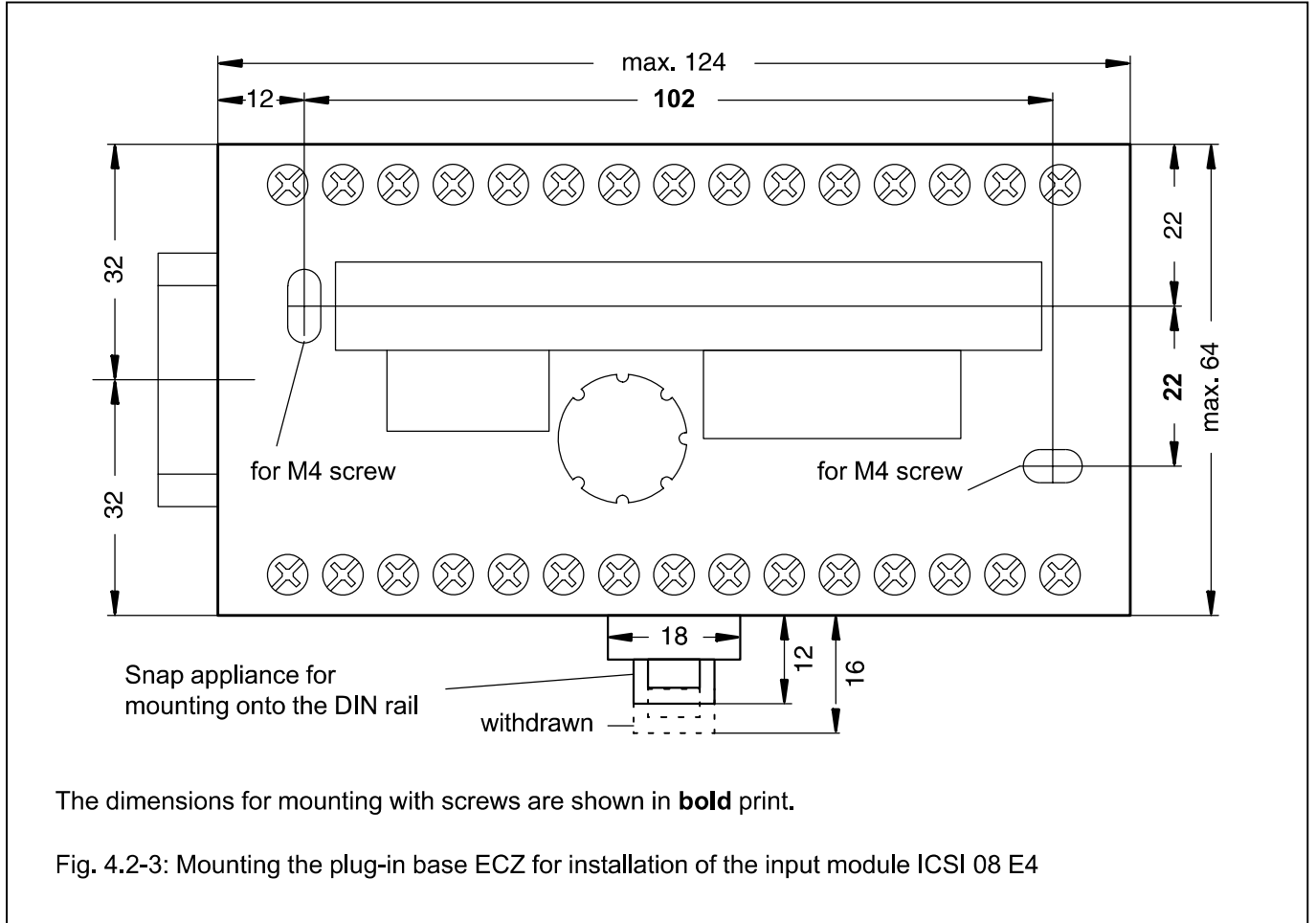

Ordering data

Order numbers	Plug-in base ECZ	FPR3700001R0001
	Module ICSI 08 E4 230 V AC	FPR3316401R0016

4.4 Digital output module ICSO 08 R1, 8 relay outputs 2 A Outputs and CS31 system bus interface electrically isolated

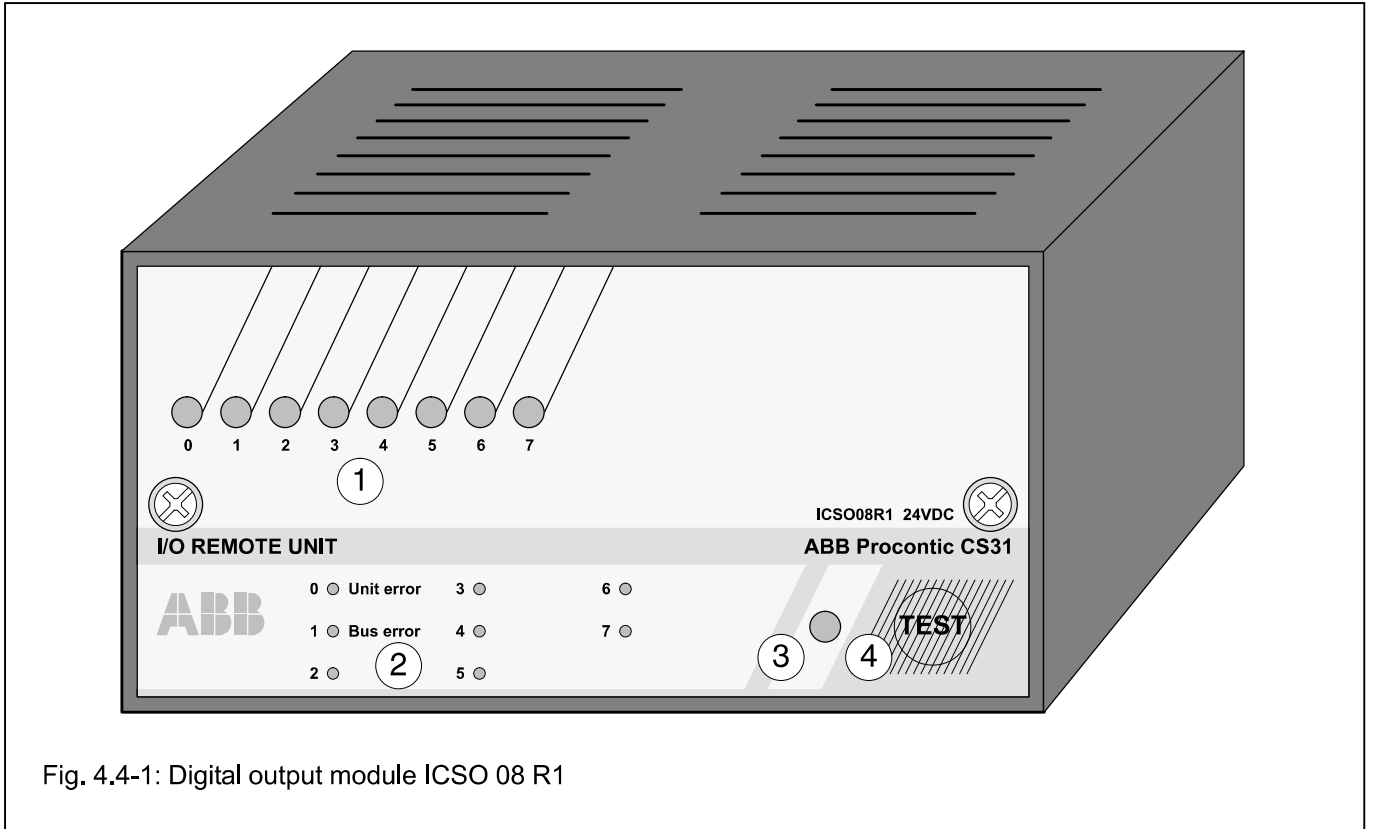

Fig. 4.4-1: Digital output module ICSO 08 R1

Contents

Intended purpose	4.4-1
Display and operating elements on the front panel	4.4-1
Electrical connection	4.4-1
Addressing	4.4-4
I/O configuration	4.4-4
Normal operation	4.4-4
Diagnosis and displays	4.4-4
Technical data	4.4-5
Dimensions for installation	4.4-6

Intended purpose

The digital output module ICSO 08 R1 is used as a remote module on the CS31 system bus. It contains 8 relay output channels with the following features:

- The relay outputs
 - are electrically isolated (from each other and from the rest of the module and
 - can be loaded with 2 A.

The module is available for supply voltages of 24 V DC and 230 V AC. For electrical connection, it has to be mounted on a plug-in base ECZ.

The CS31 system bus interface is electrically isolated from the rest of the module.

The module offers a number of diagnosis functions (see chapter "Diagnosis and displays").

Display and operating elements on the front panel

- ① 8 yellow LEDs to indicate the signal status of the outputs or for displaying error and diagnosis data
- ② List of diagnosis information concerning the LEDs when they are used for diagnosis display
- ③ Red LED for error message
- ④ Test button

Electrical connection

The module has to be mounted on the plug-in base ECZ and then fastened with two screws. The plug-in base has a mechanical coding which prevents that a module can be plugged-in with another supply voltage than set on the ECZ. Before mounting the input module, the mechanical coding has to be set to the correct supply voltage.

The following three figures show the electrical connection of the output module.

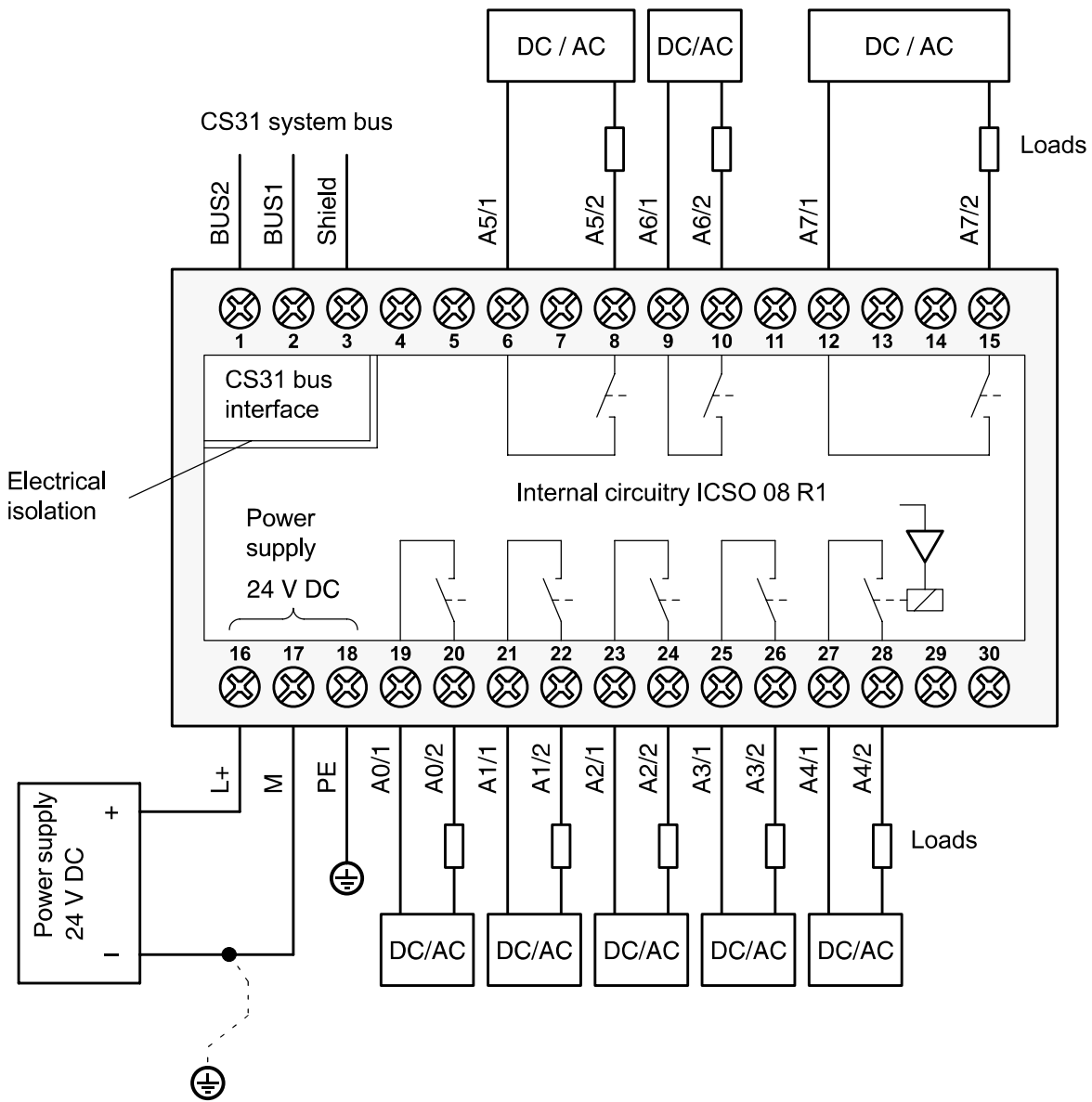

Important: The supply voltage must be included in the earthing concept of the control system (e.g. earthing of the minus pole).

Addressing and I/O configuration are set with this DIL switch.

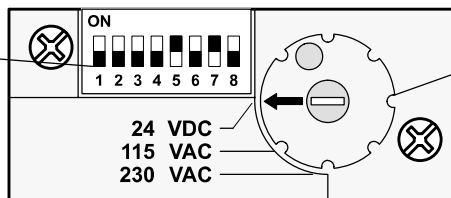

The supply voltage is set with this mechanical coding.

Fig. 4.4-2: Electrical connection of the digital output module ICSO 08 R1, supply voltage 24 V DC

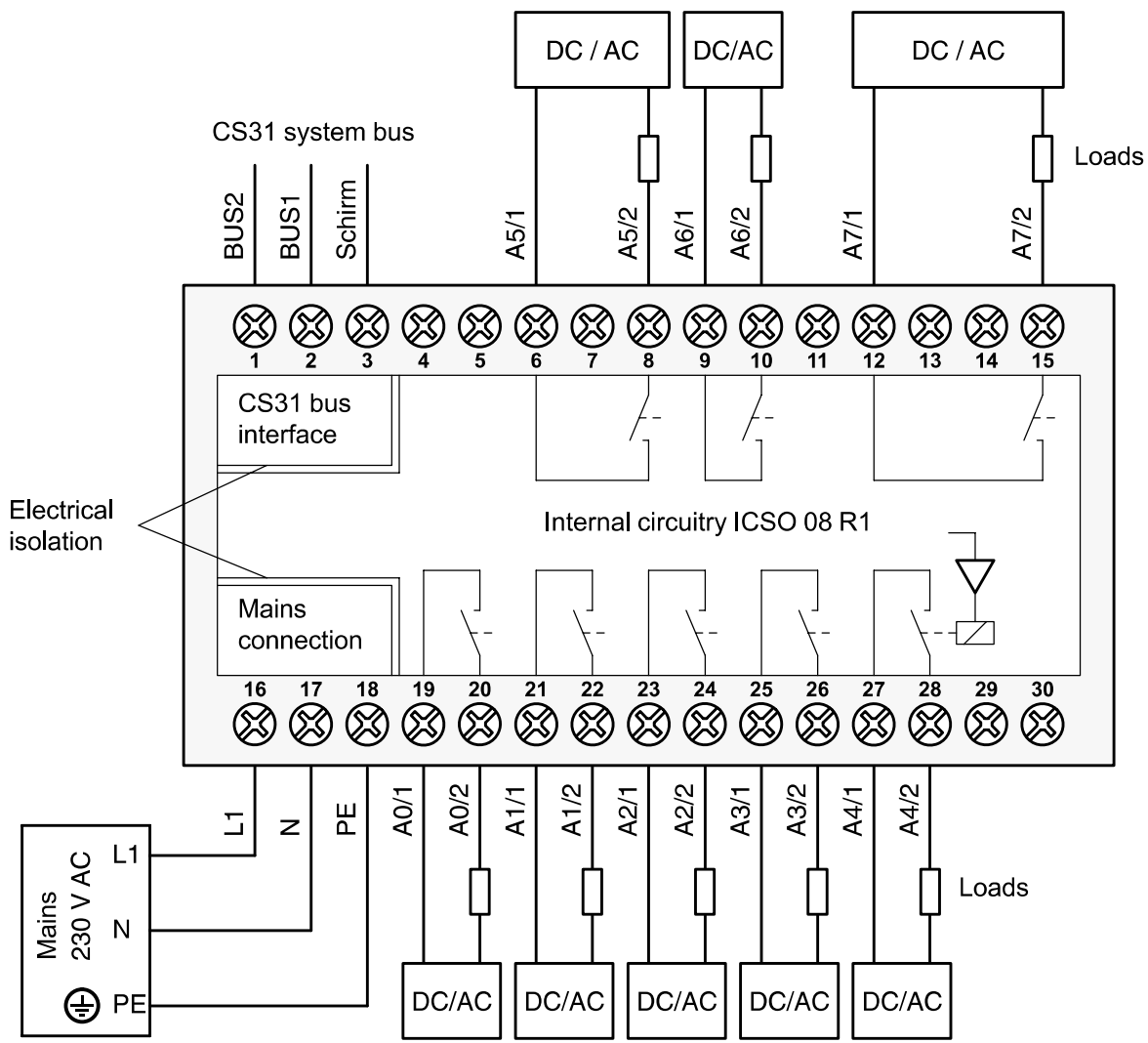

Addressing and I/O configuration are set with this DIL switch.

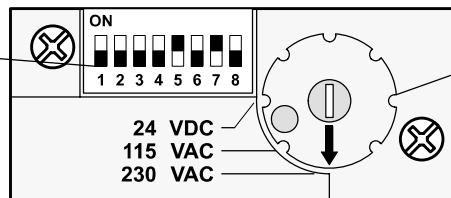

The supply voltage is set with this mechanical coding.

Fig. 4.4-3: Electrical connection of the digital output module ICSO 08 R1, supply voltage 230 V AC

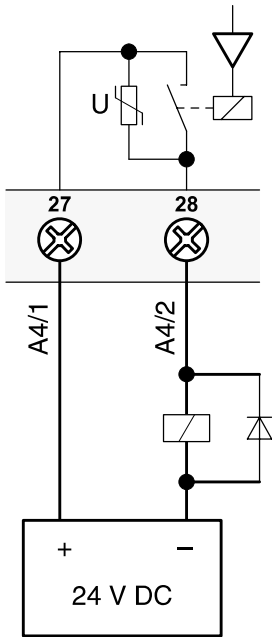

In order to suppress switching sparks when switching inductive AC loads, the relay contacts are equipped with varistors.

If, however, **inductive DC loads** are switched, **one free-wheeling diode must be mounted in parallel to each of the loads** for demagnetization.

Fig. 4.4-4: Electrical connection of inductive DC loads

Addressing

An address must be set for each module to enable the basic unit to correctly access the outputs.

The address setting is accomplished with the DIL switch on the plug-in base ECZ. When using the basic units 07 KR 91 and 07 KT 9x as bus masters, the following address assignments are valid:

Basic unit	07 KR 91 / 07 KT 9x	
DIL switch No. 8 on the ECZ	OFF (recommended)	ON
Channel		
A0	A xx,00	A xx,08
A1	A xx,01	A xx,09
A2	A xx,02	A xx,10
A3	A xx,03	A xx,11
A4	A xx,04	A xx,12
A5	A xx,05	A xx,13
A6	A xx,06	A xx,14
A7	A xx,07	A xx,15
xx: Group number of the address, set on the DIL switch of the plug-in base with the switches 2...7. Recommended addresses with 07 KR 91 / 07 KT 9x as bus masters: 08, 10, 12...60 (even-numbered addresses)		

A detailed description about "Addressing" can be found in the chapter "Addressing" of the basic units and couplers.

The module uses 8 outputs on the CS31 system bus.

I/O configuration

An I/O configuration is not necessary.

Normal operation

- After power ON the module initializes automatically. During this period the red LED (3) flashes.
- After initialization the red LED (3) goes out, if the bus runs correctly and if the module has detected no error.
- The 8 yellow LEDs (1) indicate the signal statuses of the channels A0...A7.

Diagnosis and displays

Diagnosis functions:

- Error inside the module
- Error on the CS31 system bus

If one of these errors occurs, the red LED (3) lights up.

Using the test button (4) and the LEDs (1), diagnosis information can be achieved directly at the module.

By pressing the test button the first time, the channel **A0** is selected: LED0 flashes. After releasing the test button, the diagnosis information of this channel is displayed with the 8 yellow LEDs for a period of ca. 3 seconds.

The ON status of the LEDs means:

- 0 Error inside the module (Unit error)
- 1 Error on the CS31 system bus (Bus error)
- 2...7 not used

The meaning of the LEDs (2) is also printed on the front panel of the module in English.

With every further pushing and releasing the test button, the described procedure repeats for the other channels.

After calling up the last channel (A7), a lamp test (LED test) is performed when the test button is pushed again. All 8 LEDs must light up.

After releasing the test button, the 8 LEDs show the setting of the DIL switches of the plug-in base for a period of ca. 5 seconds. LED0 shows switch 1 (LEDs 0...7 belong to the switches 1...8).

All error messages are stored in the module. They can be deleted in the following ways:

- by pressing the test button for about 10 seconds or
- with power OFF/ON or
- via the CS31 system bus.

Diagnosis data, which can be evaluated, are also sent to the basic units and couplers which work as the bus master.

For further details see the chapter "Diagnosis" in the description of the basic units and couplers.

After finishing the diagnosis procedure, the 8 LEDs again show the signal statuses of the channels. The same is valid for the pauses between the steps of the procedure.

Technical data

General data of the module

Versions	R 1022	R0026
Rated supply voltage	24 V DC	230 V AC, 50 or 60 Hz
Max. current consumption without output loads	0.2 A	
Max. power consumption without output loads		6 VA
Max. power dissipation in the module	5 W	5 W
Max. conductor cross section of the terminals (flexible lead with wire end ferrule)	2 cores of 2.5 mm ² per terminal	
Weight	Plug-in base ECZ Module ICSO 08 R1	200 g 430 g

Technical data of the outputs

Number of outputs per module	8 relay outputs (1 make contact each)
Process supply voltage / contact voltage	max. 250 V AC
Data of the relay contacts	
Switching current	max. 2 A
Total current of the 8 outputs	max. 16 A
Switching power AC	max. 500 VA
Switching power DC	max. 60 W
Minimum switching power	0.1 mA / 0.1 V DC
Contact life cycle	
mechanical	> 3 x 10 ⁷ cycles
230 V AC, 2 A resistive load	> 1 x 10 ⁵ cycles
Protection for relay contacts when switching inductive loads	
with AC	built-in varistor
with DC	a free-wheeling diode must be circuited in parallel to the load
Signalling	1 yellow LED per channel

Mechanical data

Installation methods	on a DIN rail or fastening by screws
Mounting depth including the plug-in base and a flat DIN rail	117 mm
Dimensions of the plug-in base (see the drawing below)	
snapping onto the DIN rail	centrally between top and bottom of the plug-in base
fastening by M4 screws	102 mm x 22 mm
max. outline dimensions of the plug-in base	124 mm x 64 (+12) mm

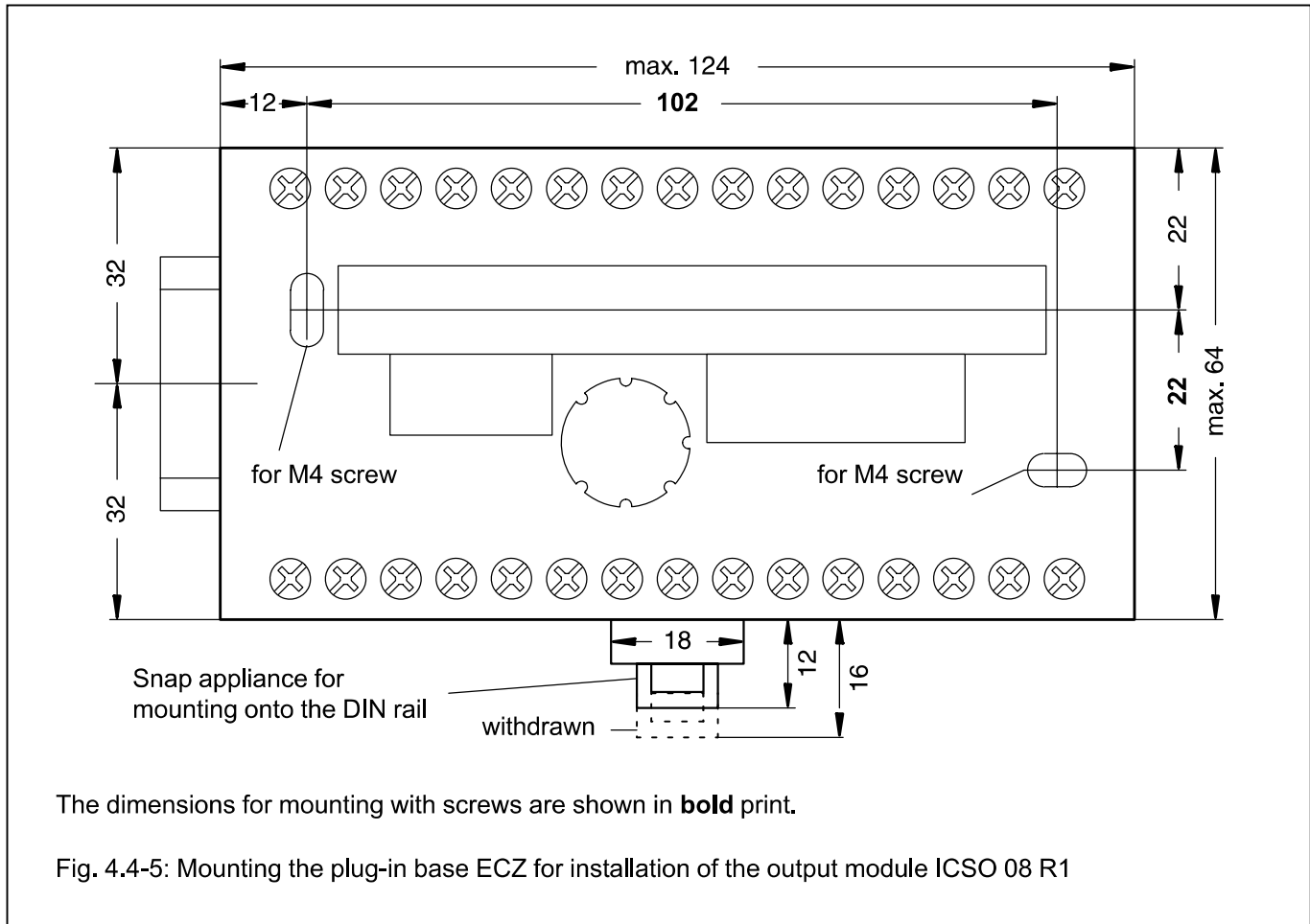

Ordering data

Order numbers	Plug-in base ECZ		FPR3700001R0001
	Module ICSO 08 R1	24 V DC	FPR3312101R1022
	Module ICSO 08 R1	230 V AC	FPR3312101R0026

4.5 Digital output module ICSO 08 Y1, 8 channels 24 V DC, 2 A Outputs and CS31 system bus interface electrically isolated

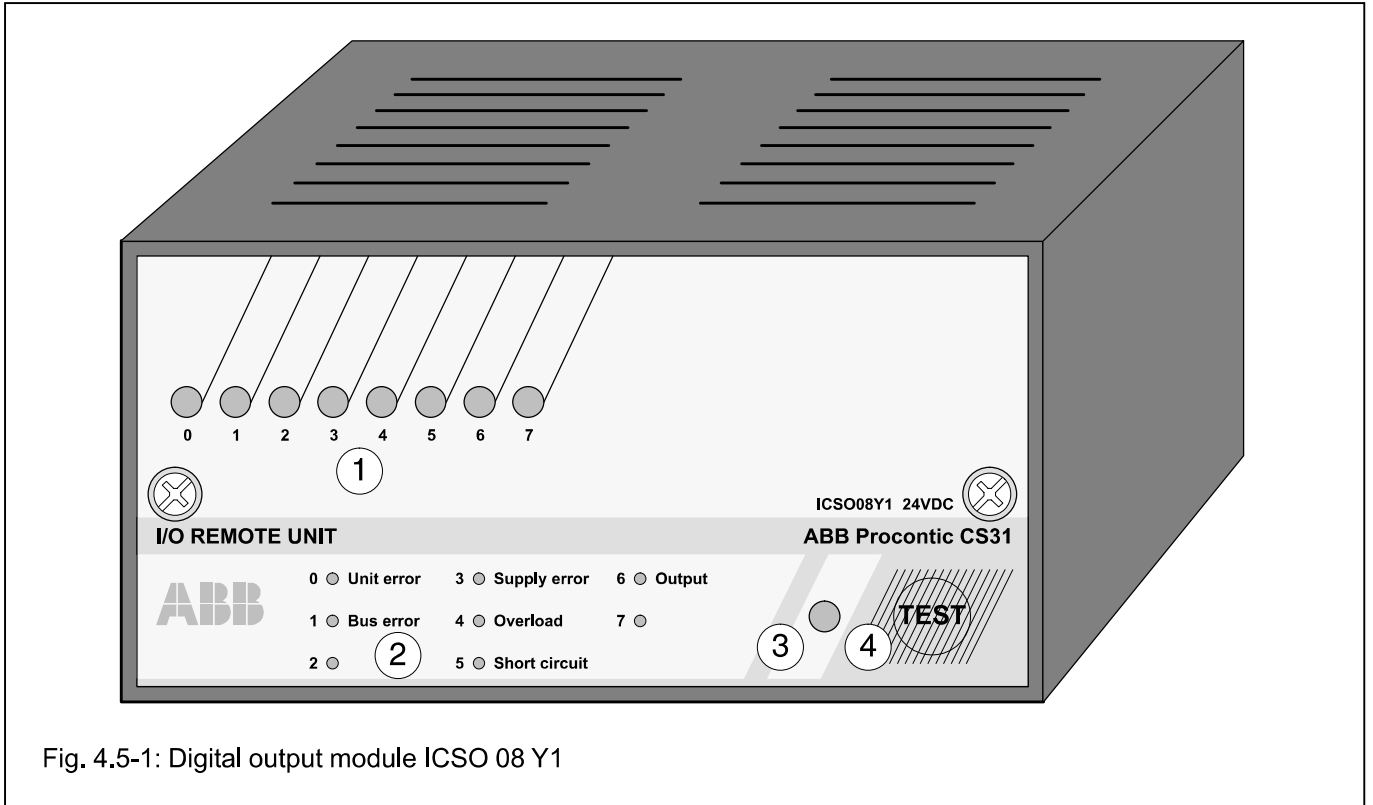

Fig. 4.5-1: Digital output module ICSO 08 Y1

Contents

Intended purpose	4.5-1
Display and operating elements on the front panel	4.5-1
Electrical connection	4.5-1
Addressing	4.5-4
I/O configuration	4.5-4
Normal operation	4.5-4
Diagnosis and displays	4.5-4
Technical data	4.5-5
Dimensions for installation	4.5-6

Intended purpose

The digital output module ICSO 08 Y1 is used as a remote module on the CS31 system bus. It contains 8 output channels with the following features:

- The outputs
 - are electrically isolated
 - have a rated voltage of 24 V DC
 - work with transistors
 - are overload and short-circuit proof and
 - can be loaded with 2 A.
- Note: The minimum load must be ≥ 50 mA. If the load is lower than 50 mA, the safe OFF state cannot be guaranteed because of the output leakage current. (Recommendation: Use module ICSC 08 L1, if the loads are lower than 50 mA.)

The module is available for supply voltages of 24 V DC and 230 V AC.

For electrical connection, it has to be mounted on a plug-in base ECZ.

The CS31 system bus interface is electrically isolated from the rest of the module.

The module offers a number of diagnosis functions (see chapter "Diagnosis and displays").

Display and operating elements on the front panel

- ① 8 yellow LEDs to indicate the signal status of the outputs or for displaying error and diagnosis data
- ② List of diagnosis information concerning the LEDs when they are used for diagnosis display
- ③ Red LED for error message
- ④ Test button

Electrical connection

The module has to be mounted on the plug-in base ECZ and then fastened with two screws. The plug-in base has a mechanical coding which prevents that a module can be plugged-in with another supply voltage than set on the ECZ. Before mounting the input module, the mechanical coding has to be set to the correct supply voltage.

The following two figures show the electrical connection of the output module.

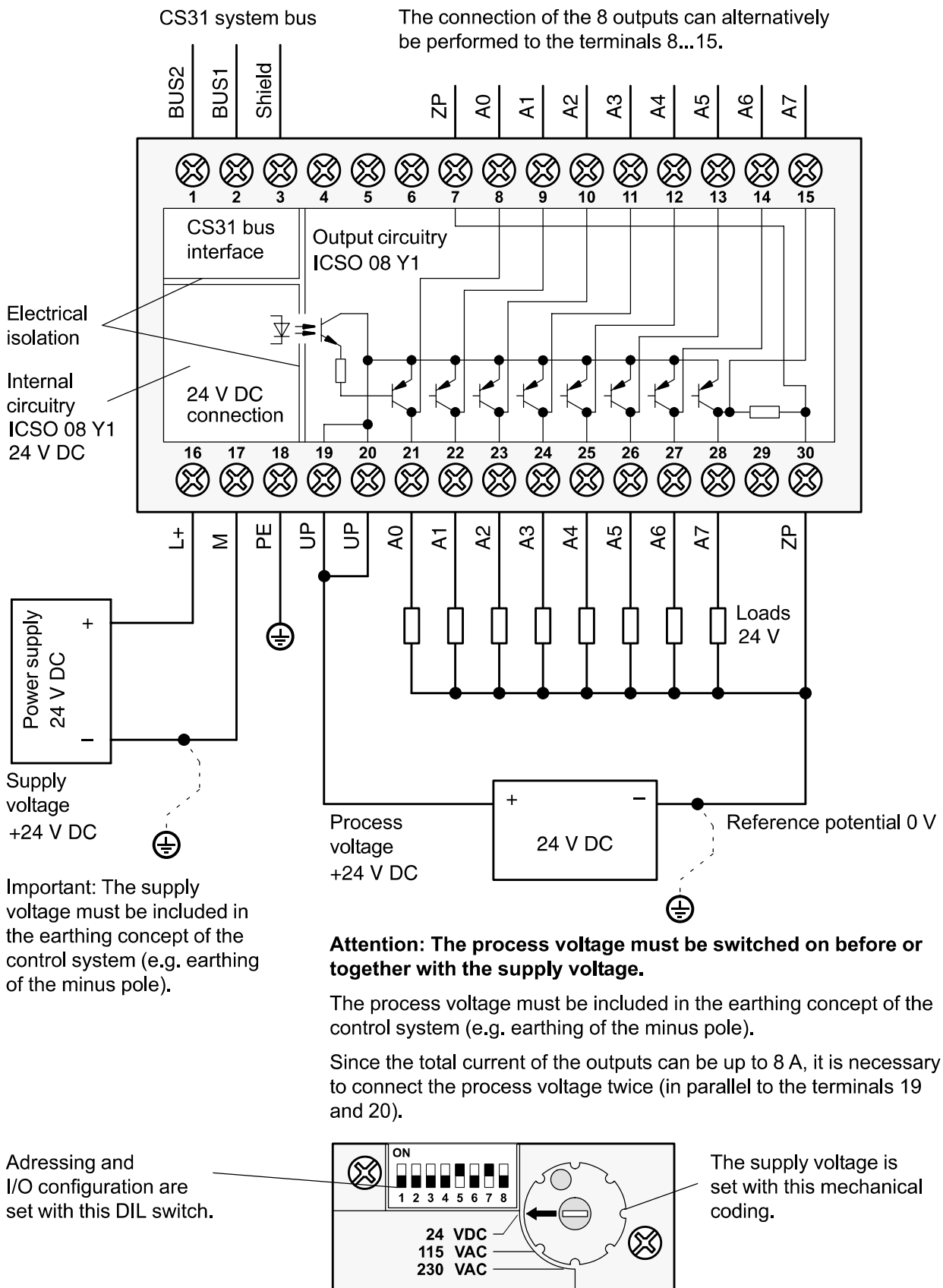
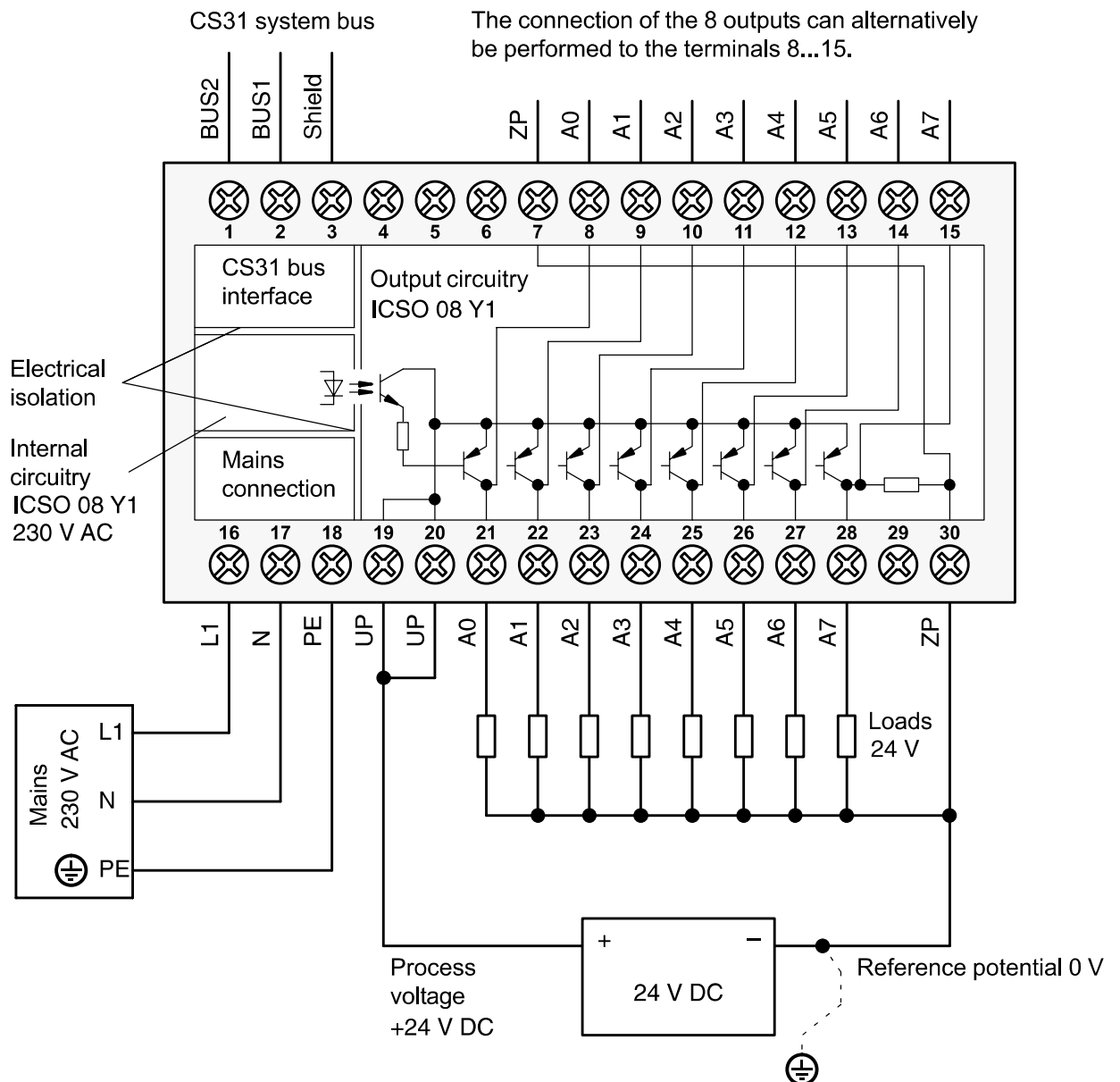

Fig. 4.5-2: Electrical connection of the digital output module ICSO 08 Y1, supply voltage 24 V DC



Attention: The process voltage must be switched on before the supply voltage of 230 V AC.

The process voltage must be included in the earthing concept of the control system (e.g. earthing of the minus pole).

Since the total current of the outputs can be up to 8 A, it is necessary to connect the process voltage twice (in parallel to the terminals 19 and 20).

Addressing and I/O configuration are set with this DIL switch.

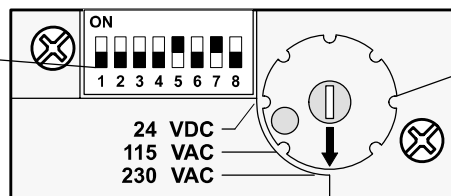

The supply voltage is set with this mechanical coding.

Fig. 4.5-3: Electrical connection of the digital output module ICSO 08 Y1, supply voltage 230 V AC

Addressing

An address must be set for each module to enable the basic unit to correctly access the outputs.

A detailed description about "Addressing" can be found in the chapter "Addressing" of the basic units and couplers.

The address setting is accomplished with the DIL switch on the plug-in base ECZ. When using the basic units 07 KR 91 and 07 KT 9x as bus masters, the following address assignments are valid:

Basic unit		07 KR 91 / 07 KT 9x	
DIL switch No. 8 on the ECZ	OFF (recommended)	ON	
Channel			
A0	A xx,00	A xx,08	
A1	A xx,01	A xx,09	
A2	A xx,02	A xx,10	
A3	A xx,03	A xx,11	
A4	A xx,04	A xx,12	
A5	A xx,05	A xx,13	
A6	A xx,06	A xx,14	
A7	A xx,07	A xx,15	

xx: Group number of the address, set on the DIL switch of the plug-in base with the switches 2...7. Recommended addresses with 07 KR 91 / 07 KT 9x as bus masters: 08, 10, 12...60 (even-numbered addresses)

The module uses 8 outputs on the CS31 system bus.

I/O configuration

An I/O configuration is not necessary.

Normal operation

- After power ON the module initializes automatically. During this period the red LED (3) flashes.
- After initialization the red LED (3) goes out, if the bus runs correctly and if the module has detected no error.
- The 8 yellow LEDs (1) indicate the signal statuses of the channels A0...A7.

Diagnosis and displays

Diagnosis functions:

- Error inside the module
- Error on the CS31 system bus
- Process voltage is OFF
- Overload
- Short-circuit

If one of these errors occurs, the red LED (3) lights up.

Using the test button (4) and the LEDs (1), diagnosis information can be achieved directly at the module.

By pressing the test button the first time, the channel **A0** is selected: LED0 flashes. After releasing the test button, the diagnosis information of this channel is displayed with the 8 yellow LEDs for a period of ca. 3 seconds.

The ON status of the LEDs means:

- 0 Error inside the module (Unit error)
- 1 Error on the CS31 system bus (Bus error)
- 2 not used
- 3 Process voltage is OFF (Supply error)
- 4 Overload
- 5 Short-circuit
- 6 Configuration as an output (Output)

The meaning of the LEDs (2) is also printed on the front panel of the module in English.

With every further pushing and releasing the test button, the described procedure repeats for the other channels.

After calling up the last channel (A7), a lamp test (LED test) is performed when the test button is pushed again. All the 8 LEDs must light up.

After releasing the test button, the 8 LEDs show the setting of the DIL switches of the plug-in base for a period of ca. 5 seconds. LED0 shows switch 1 (LEDs 0...7 belong to the switches 1...8).

All error messages are stored in the module. They can be deleted in the following ways:

- by pressing the test button for about 10 seconds or
- with power OFF/ON or
- via the CS31 system bus.

Diagnosis data, which can be evaluated, are also sent to the basic units and couplers which work as the bus master.

For further details see the chapter "Diagnosis" in the description of the basic units and couplers.

After finishing the diagnosis procedure, the 8 LEDs again show the signal statuses of the channels. The same is valid for the pauses between the steps of the procedure.

Technical data

General data of the module

Versions	R 1022	R0026
Rated supply voltage	24 V DC	230 V AC, 50 or 60 Hz
Max. current consumption without output loads	0.2 A	
Max. power consumption without output loads		6 VA
Max. power dissipation in the module	6 W	8 W
Max. conductor cross section of the terminals (flexible lead with wire end ferrule)	2 cores of 2.5 mm ² per terminal	
Weight	Plug-in base ECZ Module ICSO 08 Y1	200 g 430 g

Technical data of the outputs

Number of outputs per module	max. 8 (short-circuit and overload proof, electrically isolated)
Process supply voltage UP	24 V DC
Signal level of the outputs with signal 1	UP, (max. internal voltage drop 0.5 V)
Leakage current with signal 0	< 4 mA
Loadability of the outputs	
Rated current	2 A
Lamp load	max. 15 W
Total current of the 8 outputs	max. 8 A
Switching frequency with inductive load	max. 0.1 Hz
Overload indication	yes
Short-circuit switch-off / short-circuit indication	yes
Limitation of inductive switch-off voltage	by suppressor diode
Signalling	1 yellow LED per channel

Mechanical data

Installation methods	on a DIN rail or fastening by screws
Mounting depth including the plug-in base and a flat DIN rail	117 mm
Dimensions of the plug-in base (see the drawing below)	
snapping onto the DIN rail	centrally between top and bottom of the plug-in base
fastening by M4 screws	102 mm x 22 mm
max. outline dimensions of the plug-in base	124 mm x 64 (+12) mm

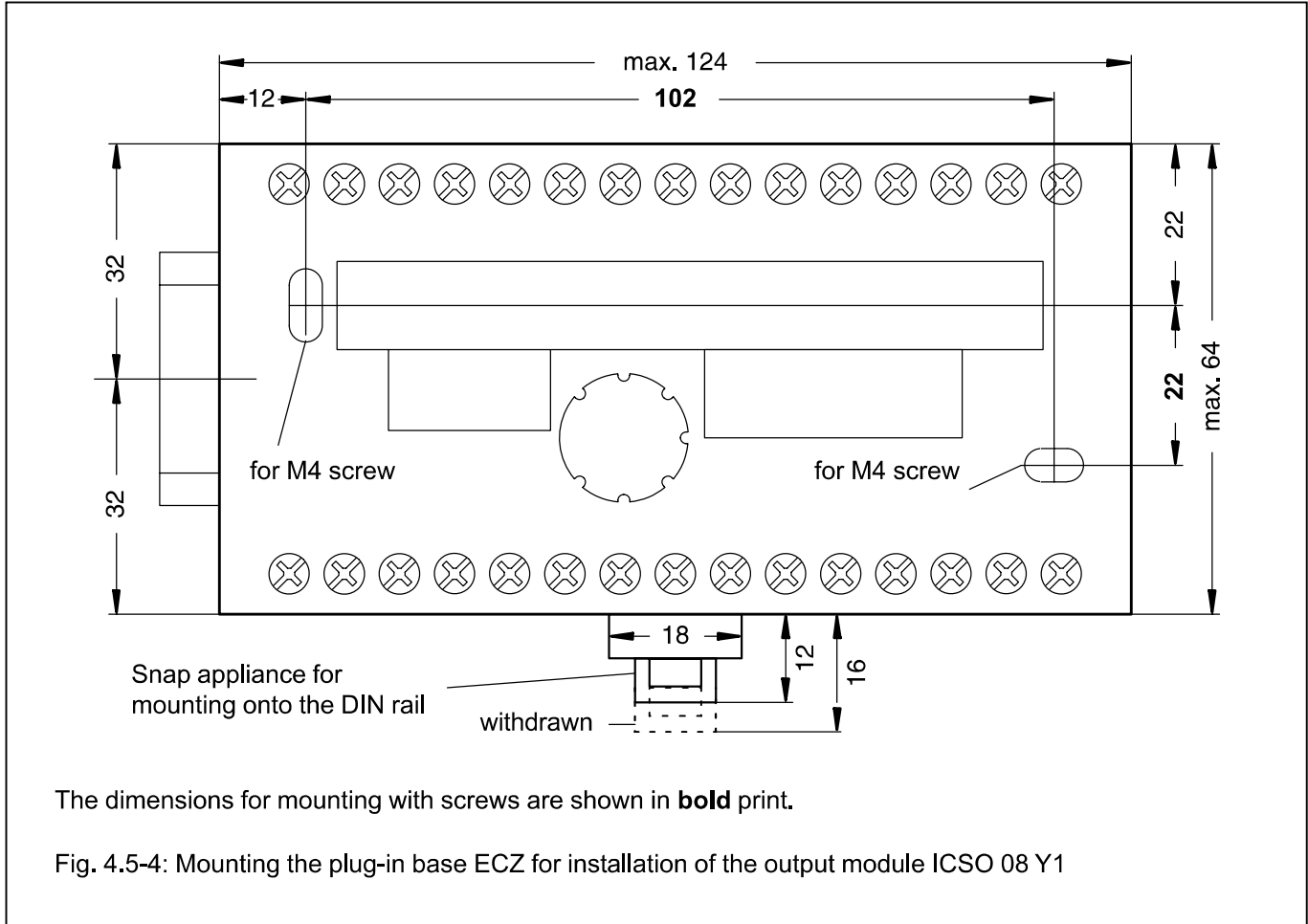

Ordering data

Order numbers	Plug-in base ECZ		FPR3700001R0001
	Module ICSO 08 Y1	24 V DC	FPR3311101R1022
	Module ICSO 08 Y1	230 V AC	FPR3311101R0026