



## Features

### Application

- MV and HV systems with distance or longitudinal differential protection as main protection as well as combined in a terminal
- Overhead lines, cables and transformer feeders.

### Distance protection

- Overcurrent or underimpedance starters with polygonal characteristic
- Five distance zones with polygonal impedance characteristic for forwards and reverse measurement
- Definite time-overcurrent back-up protection (short-zone protection)
- VT supervision
- Power swing blocking
- System logic
  - switch-onto-fault
  - overreach zone
- Teleprotection
  - The carrier-aided schemes include:
    - permissive underreaching transfer tripping
    - permissive overreaching transfer tripping
    - blocking scheme with echo and transient blocking functions
- Load-compensated measurement

- fixed reactance slope
- reactance slope dependent on load value and direction ( $<Z_{HV}$ )

- Parallel line compensation
- Phase-selective tripping for single and three-pole autoreclosure
- Four independent, user-selectable setting groups
- Suitable for application with CVTs acc. to IEC 60044.

### Longitudinal differential protection

- Independent measurement per phase
- Single-phase tripping (additional FUPLA logic available)
- Fast operation (typically 25 ms)
- Optical fiber data exchange between terminal equipment at 64 kBit/s
- Provision for transmitting 8 binary signals, e.g. for direct transfer tripping or blocking
- Continuous supervision of protection signal communication
- Provision for a power transformer in the zone of protection
  - phase compensation without interposing CTs
  - inrush restraint function.

Features (cont'd)

**Earth fault protection**

- Sensitive earth fault protection for ungrounded systems and systems with Petersen coils
- Directional comparison function for detecting high-resistance faults in neutral earthing systems
- Inverse time overcurrent function with four characteristics according to B.S. 142.

**Current and voltage functions**

- Definite time-overcurrent function with in-rush detection
- Inverse time-overcurrent function with four characteristics according to B.S. 142 and one characteristic identical to the zero-sequence relay type RXIDG
- Directional inverse and definite time overcurrent protection
- Definite time overvoltage and undervoltage function
- Thermal overload function.

**Control and monitoring functions**

- Single and three-phase multi-shot auto-reclosure
- Synchrocheck
- Breaker failure protection
- Metering
- Real and apparent power measurement
- 2 different measuring functions of voltage, current and frequency
- Fault location
- Sequence-of-events records
- Disturbance recorder
- Runtime supervision.

**Distance protection for high-voltage lines (<math>Z\_{HV}</math>)**

(Identification code SN100 and SN300)

Application

- 220 kV and 380 kV high-voltage lines in grids with grounded star-points
- Overhead lines and cables.

Distance protection

- All six fault loops are measured simultaneously (6 systems) allowing the fast detection of evolving faults also in the case of double-circuit lines
- Fast operation, minimum 21 ms and typically 25 ms, see isochrones below
- Suitable for application with CVTs according to IEC 60044
- Polygonal underimpedance starter with stability against load encroachment
- Distance measurement with polygonal operating characteristic
- Two selectable criteria for the differentiation of short circuits with or without earth. Improved detection of the earth fault with application of  $I_2$  compared with  $I_0$
- The three distance zones responsible for the protection of the line are measured simultaneously and operate without delay
  - 1 underreaching zone
  - 1 overreaching zone for comparison schemes
  - 1 reverse measuring zone for comparison schemes (echo and tripping logic at weak infeed, stabilization for double lines, resp. transmission of the blocking order for blocking systems)
- Load compensation of the reach of the first underreaching distance zone in order to avoid a possible overreach on the load exporting line-side even for high-resistance faults and double-end infeed
- Two time-delayed overreaching back-up zones
- Delayed back-up operation by the underimpedance starter, directional or nondirectional
- VT supervision
- Back-up overcurrent function
- The phase selection can be set directional and limited to the effective range of the overreach zone providing improved phase selection for single-pole autoreclosing

- Elimination of possible overreach in case of resistive phase-to-phase-to-earth faults
- Improved performance under high SIR
- Power swing blocking independent from the operating characteristic and from the place of installation of the distance relay
- System logic and carrier logic:
  - automatic switch-onto-fault protection
  - overreach zone, effective for all types of fault or for single-phase faults only, controlled by the autoreclosure function and current starter via external input or automatically in case of failure of the PLC channel
  - underreaching permissive transfer tripping with or without voltage criterion at weak infeed
  - overreaching permissive transfer tripping with echo and tripping logic at weak infeed
  - overreaching system with blocking signal
  - stabilization of the overreaching systems at change of energy direction on parallel lines
- The distance protection function may be applied for capacitive voltage transformers.

#### Back-up protection\*

- Non-directional overcurrent protection with definite time delay and/or inverse time
- Directional earth fault protection with signal comparison for selective detection of very high-resistance earth faults
- Multi-activation facility of the available function.

\* also available in the distance protection function.

#### **Process supervision**

- Sequence-of-events recorder (with fault indication)
- Disturbance recorder with analog and binary channels.

#### **Functions for programming by the user**

- Logic (AND, OR and S/R flip-flop)
- Timer/integrator.

#### **Application-specific ancillary functions (optional)**

- Graphical engineering of a logic to user specifications (CAP316). An editor and code compiler are used to generate data, which is loaded into the equipment via the HMI. This software allows signals from all functions to be interconnected and the realization of new functionalities if necessary.

#### **Self-supervision**

- Continuous self-supervision and diagnosis
- Test equipment for quantitative testing available
- Continuous supervision of the optical fiber link for the longitudinal differential function
- Plausibility check of the three-phase current and voltage inputs.

#### **Operational control**

- Multi-lingual menu-based operator program CAP2/316 based on Windows
- Four independent, user-selectable parameter sets able to be activated via binary input can be stored in REL316\*4
- Multi-activation and allocation of functions.

#### **Serial interfaces**

- Frontplate interface for local connection of a personal computer
- Back plane interface for remote communication with a station control system: LON, IEC 60870-5-103, MVB (part of IEC 61375), SPA
- Back plane interface for process bus: MVB (part of IEC 61375).

#### **Installation**

- REL316\*4 is suitable for semi-flush or surface mounting or installation in a rack.

## Application

The fully numerical protection terminal REL316\*4 is a compact line terminal. It is designed to provide high-speed selective protection in distribution, MV and HV transmission systems. It can be applied at all power system voltages and in solidly earthed, low-impedance grounded or ungrounded systems or in systems equipped with arc suppression (Petersen) coils.

REL316\*4 can be used on overhead lines and cables, long feeders, short feeders, parallel circuit lines, heavily loaded lines, lines with weak infeeds and on "short zone" lines. It detects all kinds of faults including close three-phase faults, cross-country faults, evolving faults and high-resistance ground faults.

The distance function for high-voltage lines ( $<Z_{HV}$ ) essentially has identical starting and measuring characteristics.

The differences refer to their speciality for these lines. With regard to their settings this is especially noticeable during phase selection and the adaption to source-to-line impedance conditions. The relay detects evolving faults and follow-up faults. Also at follow-up faults between parallel lines, the probability of successful single-phase autoreclosure on both systems increases significantly. The reason for this is the limited phase selection within the reach.

Distance and longitudinal differential protection combined in one terminal allows a better protection concept. For example, distance protection as a backup in addition to the traditional overcurrent backup in case of a communication failure.

Another application may be longitudinal differential protection for transformer protection with distance protection as a backup.

REL316\*4 also takes account of power swings and changes of energy direction. A switch-onto-fault condition is tripped instantaneously. The demands on CT and VT performance are moderate and the relay's response is uninfluenced by their characteristics.

The distance protection function and the directional comparison function for high-resistance earth faults can communicate with the opposite end of the line by all the usual communication media as well as by the integrated direct optical connection used for the longitudinal differential protection. The communication between the terminals of the phase-segregated longitudinal differential protection can be performed using the integrated or separate optical fiber link.

## Example

### Autoreclosure for 1½ breaker scheme

#### Three-pole tripping and autoreclosing

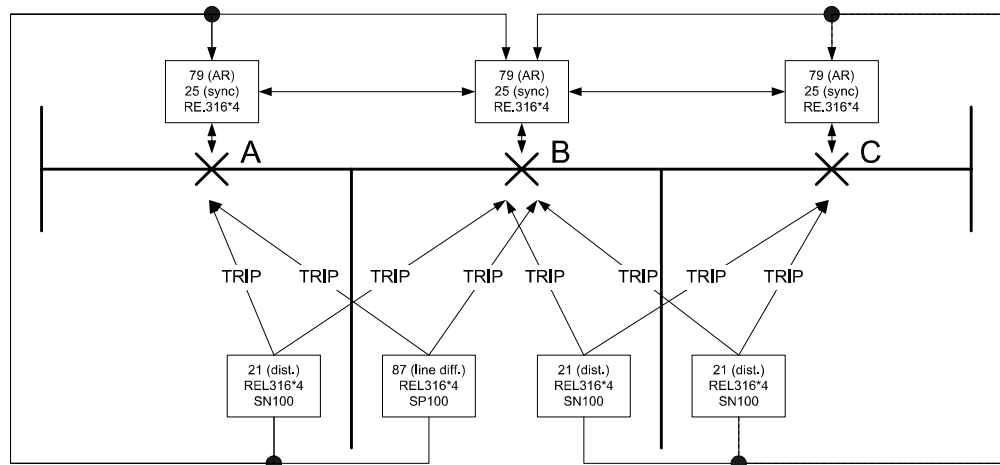

Fig. 1 Autoreclosing for 1½ breaker scheme (line-line diameter), three-pole application

The promoted solution for 1½ breaker scheme with three-pole tripping and autoreclosing is shown in Fig. 1.

- 21 Distance protection: REL316\*4 SN100
- 87 Line differential protection: REL316\*4 SP100
- 79/25 Autorecloser/synchrocheck: REL316\*4 SD050 or REC316\*4.

**Single-pole tripping and autoreclosing**

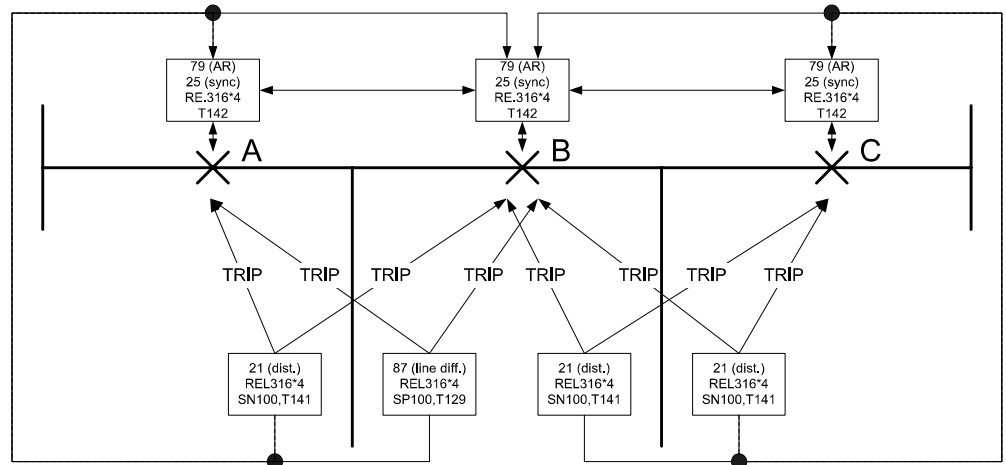

Fig. 2 Autoreclosing for 1½ breaker scheme (line-line diameter), single-pole application

The promoted solution for 1½ breaker scheme with single-pole tripping and autoreclosing is shown in Fig. 2.

- 21 Distance protection: REL316\*4 SN100, T141
- 87 Line differential protection: REL316\*4 SP100, T129
- 79/25 Autorecloser/synchrocheck: REL316\*4 SD050, T142 or REC316\*4, T142.

In these figures two lines are connected to one diameter. Each line is protected by two REL316\*4 relays. For the line on the right, the main relay is a distance protection relay (SN100), while the back-up relay is a line differential relay (SP100). The line on the right is protected with two distance protection relays (SN100). The autoreclosure functionality is achieved by one RE.316\*4 relay per breaker (e.g. REL316\*4 SD050).

For a single-pole application, the distance protection relay (SN100) is loaded with the supplementary FUPLA logic T141, the line differential relay (SP100) with the logic T129 and the autorecloser (e.g. SD050) with the logic T142.

The autoreclosure functions used for the bus breakers A and C are set as Masters and the one for the centre breaker B as Follower. Coordination is required between the autoreclosure functions. A synchrocheck function is also loaded in each relay to permit 3-pole autoreclosing.

Each line protection relay starts both bus and centre breakers for the concerned line. After a successful reclosure of the bus breaker, the centre breaker will be reclosed after a supplementary time delay. Should the bus CB autorecloser relay not be successful in its reclosing attempt, the centre CB autorecloser is blocked. If the bus CB is open or its autorecloser relay is not ready or out of service, the centre CB autorecloser will reclose the centre breaker after its own dead time without any supplementary time delay.

---

## Design

The REL316\*4 belongs to the generation of fully numerical line protection terminals, i.e. analog-to-digital conversion of the input variables takes place immediately after the input transformers and all further processing of the resulting numerical signals is performed by microprocessors and controlled by programs.

Standard interfaces enable REL316\*4 to communicate with other control systems. Provision is thus made for the exchange of data such as reactionless reporting of binary states, events, measurements and protection parameters or the activation of a different set of settings by higher level control systems.

Because of its compact design, the very few hardware units it needs, its modular software and the integrated continuous self-diagnosis and supervision functions, REL316\*4 ideally fulfils the user's expectations of a modern protection terminal at a cost-effective price. The AVAILABILITY of a terminal, i.e. the ratio between its mean operating time in service without failure and its total life, is most

certainly the most important characteristic required of protection equipment. As a consequence of the continuous supervision of its functions, this quotient in the case of REL316\*4 is typically always close to 1.

The menu-based HMI (Human Machine Interface) and the REL316\*4's small size makes the tasks of connection, configuration and setting simple. A maximum of FLEXIBILITY, i.e. the ability to adapt the protection for application in a particular power system or to coordinate with, or replace units in an existing protection scheme, is provided in REL316\*4 by ancillary software functions and the assignment of input and output signals via the HMI.

REL316\*4's RELIABILITY, SELECTIVITY and STABILITY are backed by decades of experience in the protection of lines and feeders in transmission and distribution systems. Numerical processing ensures consistent ACCURACY and SENSITIVITY throughout its operational life.

---

## Hardware

The hardware concept for the REL316\*4 line protection equipment comprises four different plug-in units, a connecting mother PCB and housing (Fig. 3):

- analog input unit
- central processing unit
- 1 to 4 binary input/output units
- power supply unit
- connecting mother PCB
- housing with connection terminals.

In the analog input unit an input transformer provides the electrical and static isolation between the analog input variables and the internal electronic circuits and adjusts the signals to a suitable level for processing. The

input transformer unit can accommodate a maximum of nine input transformers (voltage-, protection current- or measuring transformer).

Every analog variable is passed through a first order R/C low-pass filter on the main CPU unit to eliminate what is referred to as the aliasing effect and to suppress HF interferences (Fig. 4). They are then sampled 12 times per period and converted to digital signals. The analog/digital conversion is performed by a 16 Bit converter.

A powerful digital signal processor (DSP) carries out part of the digital filtering and makes sure that the data for the protection algorithms are available in the memory to the main processor.

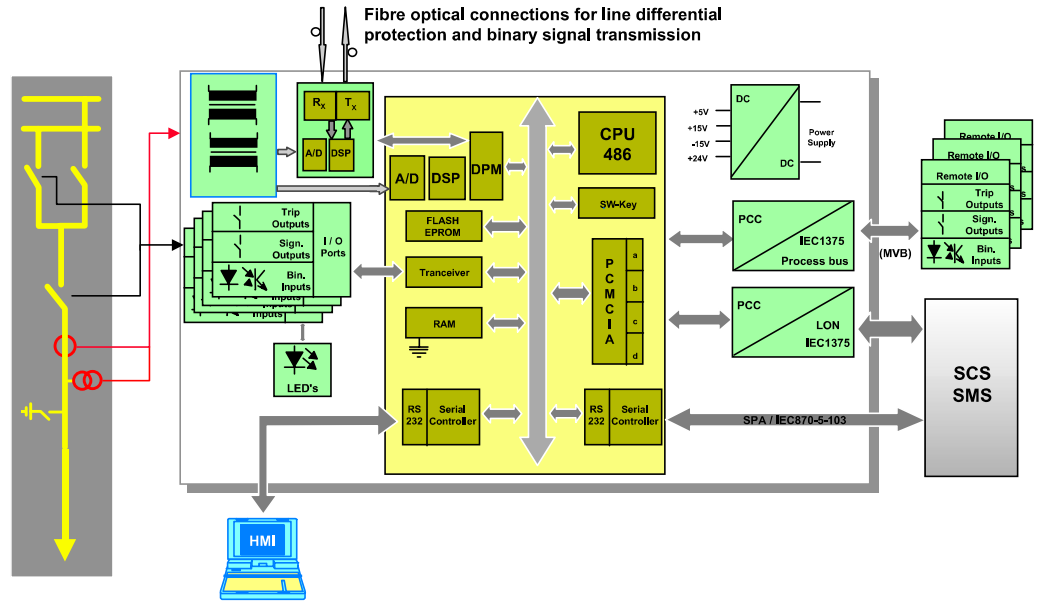

Fig. 3 Hardware platform overview (RE.316\*4)

The processor core essentially comprises the main microprocessor (Intel 80486) for the protection algorithms and dual-ported memories (DPMs) for communication between the A/D converters and the main processor. The main processor performs the protection algorithms and controls the local HMI and the interfaces to the station control system. Binary signals from the main processor are relayed to the corresponding inputs of the I/O unit and thus control the auxiliary output relays and the light emitting diode (LED) signals. The main processor unit is equipped with an RS232C serial interface via which among other things the protection settings are made, events are read and the data from the disturbance recorder memory are transferred to a local or remote PC.

On this main processor unit there are two PCC slots and one RS232C interface. These serial interfaces provide remote communication to the station monitoring system (SMS) and station automation system (SAS) as well as to the remote I/Os.

REL316\*4 can have one to four binary I/O units each. These units are available in three versions:

- a) two tripping relays with two heavy-duty contacts, 8 optocoupler inputs and 6 signalling relays Type 316DB61.
- b) two tripping relays with two heavy-duty contacts, 4 optocoupler inputs and 10 signalling relays Type 316DB62.
- c) 14 optocoupler inputs and 8 signalling relays Type 316DB63.

When ordering REL316\*4 with more than 2 I/O units, casing size N2 must be selected.

According to whether one or two I/O units are fitted, there are either 8 LEDs or 16 LEDs visible on the front of the REL316\*4.

**Software**

Both analog and binary input signals are conditioned before being processed by the main processor: As described under hardware above, the analog signals pass through the sequence input transformers, shunt, low-pass filter (anti-aliasing filter), multiplexer and A/D converter stages and DSP. In their digital

form, they are then separated by numerical filters into real and apparent components before being applied to the main processor. Binary signals from the optocoupler inputs go straight to the main processor. The actual processing of the signals in relation to the protection algorithms and logic then takes place.

**Signal data flow**

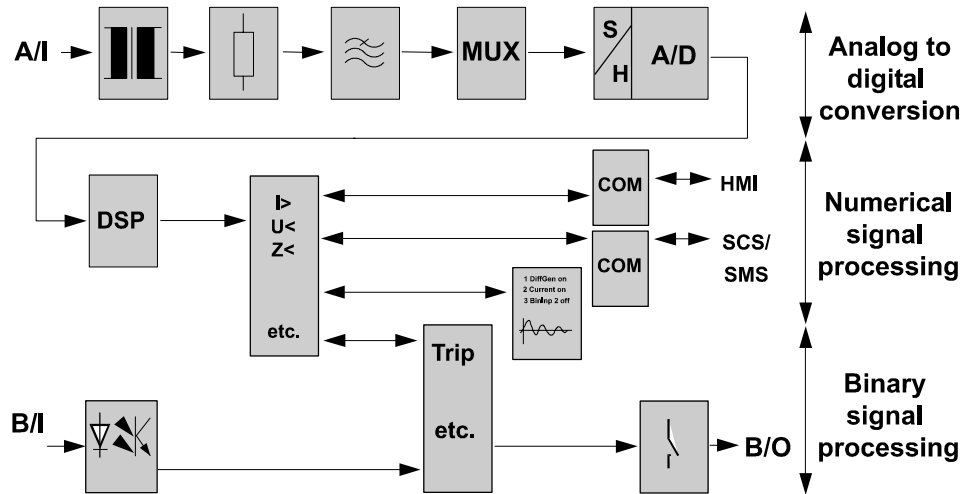

Fig. 4 Data flow

**Graphical engineering tool**

The graphical programming language used in the tool CAP316 makes CAP316 a powerful and user-friendly engineering tool for the engineering of the control and protection units RE.216/316\*4. It is similar to IEC 1131. CAP316 permits the function blocks representing the application to be directly translated into an application program (FUPLA) capable of running on the processors of the control and protection units RE.316\*4. The program packet contains an extensive library of function blocks. Up to 8 projects (FUP- LA's created with CAP316) are able to run simultaneously on a RE.316\*4.

**List of functions**

- Binary functions:
- AND AND gate
  - ASSB Assign binary
  - B23 2-out-of-3 selector
  - B24 2-out-of-4 selector
  - BINEXTIN External binary input
  - BINEXOUT External binary output

- COUNTX Shift register
- CNT Counter
- CNTD Downwards counter
- OR OR gate
- RSFF RS flip-flop
- SKIP Skip segment
- TFF T flip-flop with reset
- TMOC Monostable constant
- TMOCS, TMOCL Monostable constant short, long
- TMOI Monostable constant with interrupt
- TMOIS, TMOIL Monostable constant with interrupt short, long
- TOFF Off delay
- TOFFS, TOFFL Off delay short, long
- TON On delay
- TONS, TONL On delay short, long
- XOR Exclusive OR gate

- Analog functions:
- ABS Absolute value
  - ADD Adder/subtractor
  - ADDL Long integer adder/subtractor

ADMUL	Adder/multiplier	LIM	Limiter
CNVIL	Integer to long integer converter	LOADS	Load shedding function
CNVLBCD	Long integer to BC converter	MAX	Maximum value detector
CNVLI	Long integer to integer converter	MIN	Minimum value detector
CNVLP	Long integer to percent converter	MUL	Multiplier
CNVPL	Percentage to long integer converter	MULL	Long integer multiplier
DIV	Divider	NEGP	Percent negator
DIVL	Long integer divider	PACW	Pack binary signals into integer
FCTL	Linear function	PDTS, PDTL	Differentiator
FCTP	Polynomial function	PT1S, PT1L	Delayed approximation
FILT	Filter	SQRT	Square root
INTS, INTL	Integrator	SWIP	Percent switch
KMUL	Factor multiplier	THRLL	Lower limit threshold
		THRUL	Upper limit threshold
		TMUL	Time multiplier
		UPACW	Unpack binary signals from an integer.

**Example:**

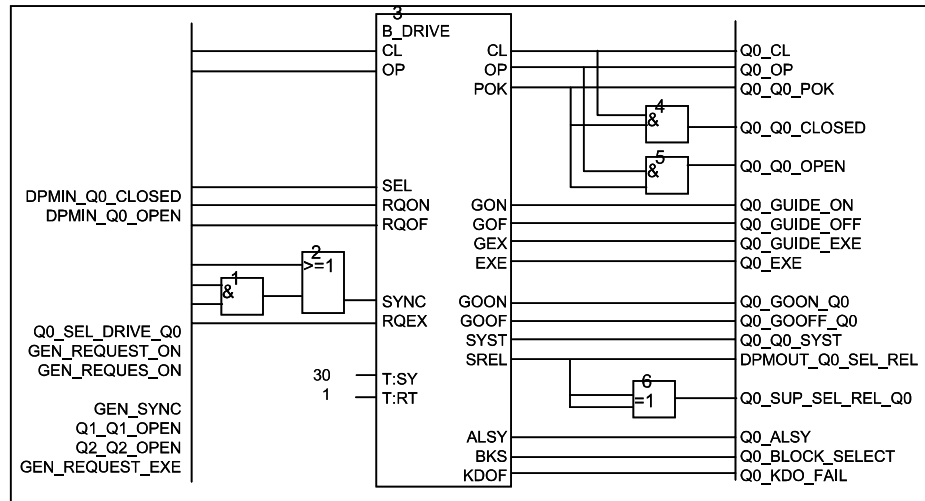

Part of a FUPLA application (Q0: Control and interlocking logic for three objects Q0, Q1, Q2. B\_DRIVE is a macro composed of binary function blocks)

## Functions

The library of function modules for REL316\*4 includes a variety of protection and ancillary functions from which the user can choose according to relay version (see "Ordering data"). Within the constraints of the available processing capacity, the same function may be included several times. Four parameter sets may be selected via binary inputs. The individual functions are described below.

### Distance protection

The distance protection function can have either overcurrent or underimpedance starters. They are equally suitable for use in solidly grounded, ungrounded or impedance grounded systems. In the case of ungrounded and impedance grounded systems, all the relays in the system have to have identically set phase-preference logics to maintain selectivity for cross-country faults. The following phase-preference schemes are available:

RTS	acyclic (R before T before S)
RST	acyclic (R before S before T)
TSR	acyclic (T before S before R)
TRS	acyclic (T before R before S)
SRT	acyclic (S before R before T)
STR	acyclic (S before T before R)
RTSR	cyclic (R bef. T, T bef. S, S bef. R)
TRST	cyclic (T bef. R, R bef. S, S bef. T).

The relay detects ground faults on the basis of the neutral current and/or neutral voltage.

Distance measurement is performed in the first, overreach and reverse zones simultaneously. Every zone has a wide, completely independent setting range and an independent setting for the direction of measurement. Four directional zones are provided, the last of which can also be configured to be non-directional. Overreach and reverse measuring zones are for use in transfer tripping schemes. The distance measuring characteristic is a polygon with a slightly inclined reactance line which has proved to be an optimum in practice. Where the voltage measured by the relay for a fault is too low, the inclusion of a healthy phase voltage as reference, respectively the use of a memory feature (close three-phase faults) ensures the integrity of the directional decision. The mutual impedance on parallel circuit lines can be compensated by correspondingly setting the zero-sequence compensation factor ( $k_0$ ) or by taking account of the neutral current of the parallel circuit.

A VT supervision function is also included which monitors the zero-sequence component ( $U_0 \cdot I_0$ ) and/or the negative-sequence component ( $U_2 \cdot I_2$ ), the latter being of advantage in ungrounded systems or systems with poor grounding.

An independent overcurrent back-up measurement is provided which becomes a short-zone scheme as soon as the feeder isolator is opened. When the back-up overcurrent measurement picks up, the distance relay is enabled in spite of any blocking signals (e.g. VT supervision or power swing blocking) which may be active. The power swing blocking feature included in the distance function is based on the evaluation of the variation of  $U \cdot \cos\phi$ . This principle of detecting power swings is entirely independent of the operating characteristic and location of the distance relay. It covers the range 0.2 to 8 Hz.

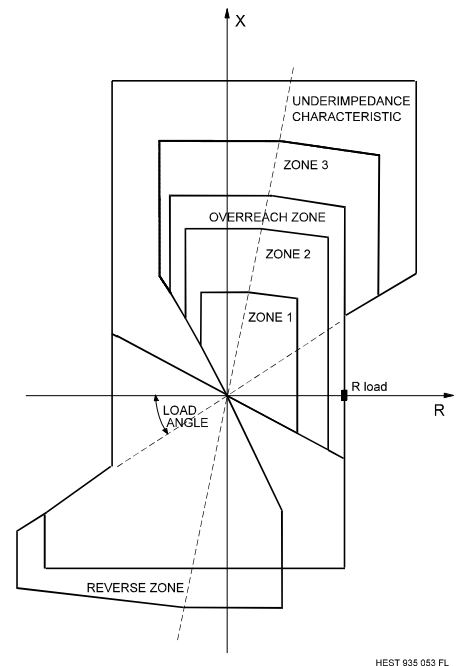

Fig. 5 Distance function characteristic

The tripping logic can be configured for all the usual transfer tripping schemes such as:

- overreaching (for autoreclosure with or without communications channel)
- permissive underreaching transfer tripping (including weak infeed logic)

- permissive overreaching transfer tripping (with echo tripping in the case of a weak-infeed and blocking logic for change of energy direction)
- blocking scheme (with blocking logic for change of energy direction).

The tripping logic provides access for the user to disable or enable a variety of functions such as the type communications channel, the switch-onto-fault logic, the overreaching zone, the VT supervision logic and whether tripping by the function should be single or three-phase.

**Distance protection for high-voltage lines**

The distance protection function ( $<Z_{HV}$ ) is especially suited for 220 kV and 380 kV lines.

The "HV distance" function essentially has identical starting and measuring characteristics and the same setting parameters as the standard "distance" function.

The setting parameters for not effectively earthed networks have been omitted and a few new ones added, especially in connection with an improved phase selection.

The operating times for the "HV distance" function are shown in the form of isochrones. (see Section 'High-voltage distance protection function operating times'). All other functions remain unchanged.

**Longitudinal differential protection**

The longitudinal differential protection function included with REL316\*4 is suitable for the protection of

- overhead lines
- cables
- transformer feeders.

It operates according to the proven transformer protection algorithm used in RET316\*4 and exhibits the same outstanding characteristics with respect to through-fault stability and minimum CT performance.

The scheme is phase-selective and takes full advantage of the high data transfer rate of 64 kBit/s possible with an optical fiber link to sample the analog input variables at both ends of the line and transfers the corresponding values to the opposite station without almost any delay.

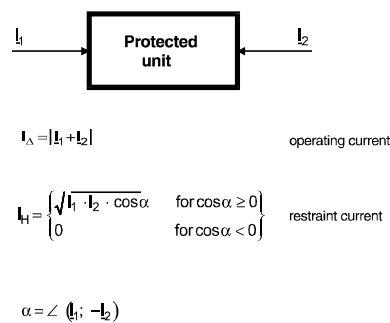
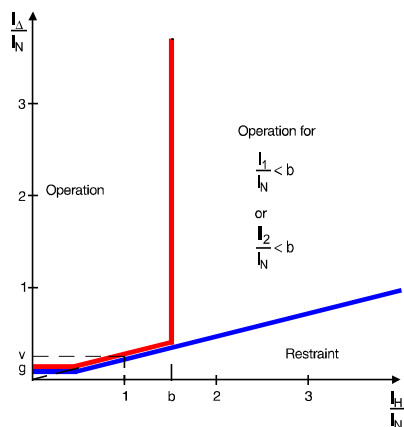

HEST 965001 C

Fig. 6 Operating characteristic of the longitudinal differential function

Functions (cont'd)

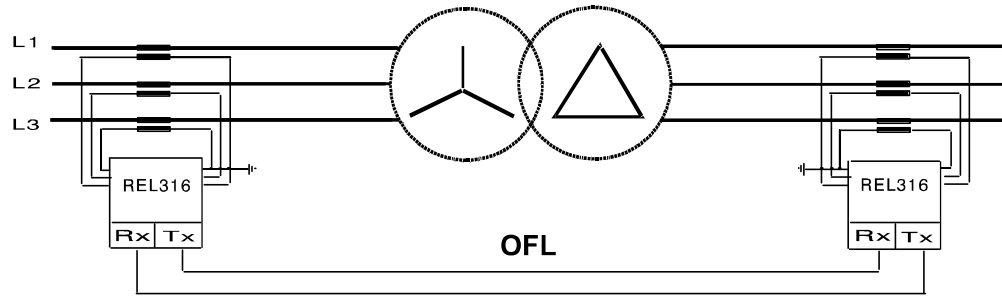

Fig. 7 Longitudinal differential protection with a power transformer in the protected zone

Tripping takes place should the comparison of the values in the terminal stations result in a differential current  $I_{\Delta}$  above a given level (see operating characteristic in Fig. 6). The self-supervision function of the optical fiber link operates at such a speed that an additional enabling signal is not necessary.

Interposing CTs are not needed where the protected unit includes a power transformer (Fig. 7). The settings for the protection are made using a convenient control program running on a personal computer.

Provision is made for transmitting other signals via the optical fiber link in addition to those of the longitudinal differential function. These might be intertripping signals to the remote station generated by other internal protection functions or applied to the terminals binary inputs by some other external terminal. A ground fault comparison scheme can thus operate via the same optical fiber link. When the terminal equipment in one station is being tested, the equipment in the other station can be remotely blocked.

When the longitudinal protection function is in use, a maximum of six analog inputs is available, e.g. three current and three voltage measurements for main and back-up protections and for the disturbance recorder. Following analog-to-digital conversion, the signals branch in two directions. All six go to the main processor for evaluation for the local protection functions and the three corresponding to the local phase currents are additionally converted to light signals by an optical modem for transmission to the opposite sta-

tion where they are evaluated in relation to the local current signals. Similarly the currents measured and digitized in the remote station are transferred to the local station and evaluated. A digital signal processor (DSP) ensures that the sampling and coordination of the signals in the two stations and also the transmission between the stations is properly synchronized. Thus there are two current signals available for the longitudinal differential comparison of each phase in both stations. Comparison is performed in the main processor according to the proven algorithm mentioned above.

As previously explained, the longitudinal differential function operates in conjunction with an optical fiber link between the stations at the ends of the transmission line. The signals are transmitted by a LED diode with a wavelength of 1300 nm and are coupled by a Type FC optical connector. Depending on the attenuation of the optical cable used, distances of up to 28 km can be covered. Repeaters have to be used for longer distances which in the case of FOX 6 Plus or Fox 20 enable transmission over distances up to 120 km (Fig. 8).

In REL316\*4 units for longitudinal differential applications, the standard distance protection function can also be activated. The operation for single-pole autoreclosure is foreseen with the T129 logic. The other standard software of the line protection terminal is uninfluenced. Other optional functions from the software library are also provided (see Table of codes).

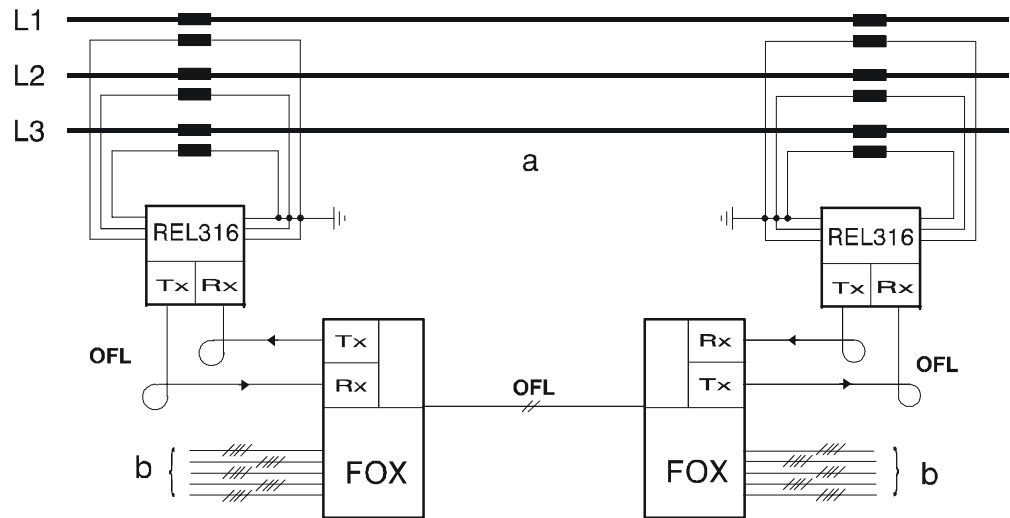

Fig. 8 Optical fiber link (OFL) using communications system Type FOX with a data transfer rate of 2 MBit/s

#### Autoreclosure

The autoreclosure function included in REL316\*4 permits up to four three-phase reclosure cycles to be carried out, each with an independently adjustable dead time for fast and slow autoreclosure. Where single-phase reclosure is being applied, the first reclosure is the single-phase one and the others are three-phase.

The autoreclosure function can also be loaded several times in the same parameter set. This function also contains an integrated additional logic (FUPLA). This allows a customer-specific AR functionality. Both these possibilities have been used for the CH standard AR. Two AR functions are loaded for this: the first function with additional logic serves as fast autoreclosure and the second function as slow autoreclosure.

The integrated autoreclosure function for high-voltage lines (REL316\*4/SN300) is employed on lines without local protection redundancy.

A separate autoreclosure unit is especially suitable for lines with redundant protection.

This unit enables practically all conventional and all modern line protection relays suitable for single-phase tripping to be connected to one system.

#### Synchrocheck

The synchrocheck function determines the difference between the amplitudes, phase angles and frequencies of two voltage vectors. Checks are also included to detect a dead line or busbar.

#### Thermal overload

The thermal overload function can be used for either cables or overhead lines. It is equipped with alarm and tripping stages and has a wide setting range for adjusting the time constant to match that of the protected unit.

#### Definite time voltage function

The voltage function can be set to operate on overvoltage or undervoltage with a definite time delay. Either single or three-phase measurements can be performed.

#### Definite time current function

The current function can be set to operate on overcurrent or undercurrent with a definite time delay. Either single or three-phase measurements can be performed.

#### Inverse time overcurrent function

The operating time of the inverse time overcurrent function reduces as the fault current increases and it can therefore achieve shorter operating times for fault locations closer to the source. Four different characteristics according to British Standard 142 designated normal inverse, very inverse, extremely inverse and long time inverse but with an extended setting range are provided. The function can be configured for single-phase mea-

## Functions (cont'd)

surement or a combined three-phase measurement with detection of the highest phase current.

### **Directional overcurrent protection**

The directional overcurrent protection function is available either with inverse time or definite time overcurrent characteristic. This function comprises a voltage memory for faults close to the relay location. The function response after the memory time has elapsed can be selected (trip or block).

### **Inverse time ground fault overcurrent function**

The inverse time ground fault overcurrent function monitors the neutral current of the system which is either measured via a neutral current input transformer or derived internally in the terminal from the three-phase currents. Four different characteristics according to British Standard 142 designated normal inverse, very inverse, extremely inverse and long time inverse but with an extended setting range are provided.

### **Directional ground fault function for ungrounded systems or systems with Petersen coils**

The sensitive ground fault protection function for ungrounded systems and systems with Petersen coils can be set for either forwards or reverse measurement. The characteristic angle is set to  $\pm 90^\circ (U_0 \cdot I_0 \cdot \sin\phi)$  in ungrounded systems and to  $0^\circ$  or  $180^\circ (U_0 \cdot I_0 \cdot \cos\phi)$  for systems with Petersen coils. The neutral current is always used for measurement in the case of systems with Petersen coils, but in ungrounded systems its use is determined by the value of the capacitive current and measurement is performed by a core-balance CT to achieve the required sensitivity.

### **Directional ground fault function for grounded systems**

A sensitive directional ground fault function based on the measurement of neutral current and voltage is provided for the detection of high-resistance ground faults in solidly or low-resistance grounded systems. The scheme operates either in a permissive or blocking mode and can be used in conjunction with an inverse time ground fault overcurrent function. In both cases the neutral current and voltage can be derived either externally or internally.

### **Frequency function**

The frequency function is based on the measurement of one voltage. This function is able to be configured as maximum or minimum function and is applied as protection function and for load shedding. By multiple configuration of this function almost any number of stages can be realized.

### **Rate-of-change of frequency**

This function offers alternatively an enabling by absolute frequency. It contains an under-voltage blocking facility. Repeated configuration of this function ensures a multi-step setup.

### **Measuring**

Both measuring functions measure the single-phase rms values of voltage, current, frequency, real power and apparent power for display on the local HMI or transfer to the station control system. A choice can be made between phase-to-neutral and phase-to-phase voltages.

### **Ancillary functions**

Ancillary functions such as a logic and a delay/integrator enable the user to create logical combinations of signals and pick-up and reset delays.

A runtime supervision feature enables checking the opening and closing of all kinds of breakers (circuit-breakers, isolators, ground switches...). Failure of a breaker to open or close within an adjustable time results in the creation of a corresponding signal for further processing.

### **Plausibility check**

The current and voltage plausibility functions facilitate the detection of system asymmetries, e.g. in the secondary circuits of CTs and VTs.

### **Sequence-of-events recorder**

The event recorder function provides capacity for up to 256 binary signals including time marker with a resolution in the order of milliseconds and gives the distance to a fault expressed as a percentage of a specified reference reactance, e.g. the reactance of the protected line.

### **Disturbance recorder**

The disturbance recorder monitors up to 9 analog inputs, up to 16 binary inputs and internal results of protection functions. The capacity for recording disturbances depends on the duration of a disturbance as deter-

mined by its pre-disturbance history and the duration of the disturbance itself. The total recording time is approximately 5 s.

**Human Machine Interface (HMI) - CAP2/316**

For local communication with REL316\*4, there is the setting software CAP2/316 available which is based on Windows. This software runs under the following operating systems:

- Windows NT 4.0
- Windows 2000.

This optimal programming tool is available for engineering, testing, commissioning and operation. The software can be used either ON-LINE or OFF-LINE and furthermore contains a DEMO mode.



For each protection function a tripping characteristic is displayed. Apart from the basic understanding of the protection functions, the graphical display of these functions also makes the setting of the parameters clearer.

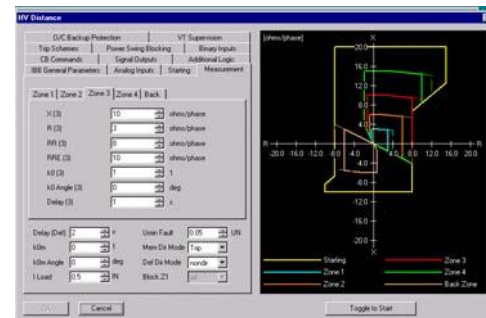

Any desired protection function can be selected from the software library of all released protection functions by means of the drag-and-drop feature.

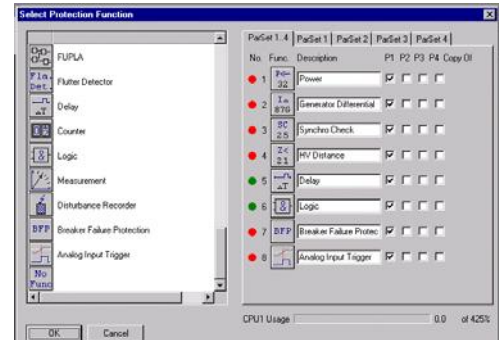

**Built-in HMI**

The front HMI unit serves primarily for the signalling of actual events, measurands and diagnostic data. Settings are not displayed.

Features:

- Measurand display
  - Amplitude, angle, frequency of analog channels
  - Functional measurands
  - Binary signals
- Event list
- Operating instructions
- Disturbance recorder information
- Distance to fault indication
- Diagnostic information
- Acknowledgment functions
  - Resetting LEDs
  - Resetting latched outputs
  - Event erasing
  - Warm start.

**Remote communication**

REL316\*4 is able to communicate with a station monitoring and evaluation system (SMS) or a station automation system (SAS) via an optical fiber link. The corresponding serial interface permits events, measurements, disturbance recorder data and protection settings to be read and sets of parameter settings to be switched.

## Functions (cont'd)

Using the LON bus permits in addition the exchange of binary information between the individual bay controllers, e.g. signals for station interlocking.

### Remote in- and outputs (RIO580)

Using the process bus type MVB remote in- and output units (500RIO11) can be connected to the RE.316\*4 terminals. The input and output channels can be extended to a large number by using the RIO580 remote input/output system. Installing 500RIO11 I/O close to the process reduces the wiring dramatically, since they are accessible via fiberoptic link from the RE.316\*4 terminals.

Analog signals can also be connected to the system via the 500AXM11 from the RIO580 family:

- DC current     4...20 mA  
                  0...20 mA  
                  -20...20 mA
- DC voltage     0...10 V  
                  -10...10 V
- Temp. sensor   Pt100, Pt250, Pt1000,  
                  Ni100, Ni250, Ni1000.

### Self-diagnosis and supervision

RE.316\*4's self-diagnosis and supervision functions ensure maximum availability not only of the protection terminal itself, but also of the power system it is protecting. Hardware failures are immediately signalled by an alarm contact. In particular, the external and internal auxiliary supplies are continuously supervised. The correct function and tolerance of the A/D converter are tested by cyclically converting two reference voltages. Special algorithms regularly check the processor's memories (background functions). A watchdog supervises the execution of the programs.

The program execution itself is monitored by a watchdog function for each processor.

An important advantage of the extensive self-diagnosis and supervision functions is that periodic routine maintenance and testing are reduced.

The optical fiber link is also supervised on terminal equipped with the longitudinal differential function. For this purpose test data are transmitted in addition to the protection signals to test the integrity of the communications channel. The supervision function also detects the failure of the auxiliary supply in one terminal station. In the event that the optical fiber link should fail, the back-up protection functions remain operational.

### Supporting software

The operator program facilitates configuration and setting of the protection, listing parameters, reading events and listing the various internal diagnostic data.

The evaluation programs REVAL and E\_wineve (Windows NT/Windows 2000) are available for viewing and evaluating the disturbances stored by the disturbance recorder. Where the disturbance data are transferred via the communications system to the disturbance recorder evaluation station, the file transfer program WinCom (Windows NT/Windows 2000) is also used.

The program XSCON is available for conversion of the RE.316\*4 disturbance recorder data to ABB's test set XS92b format. This offers reproduction of electrical quantities recorded during a fault.

**Technical data  
hardware**

**Table 1: Analog input variables**

Number of inputs according to version, max. 9 analog inputs (voltages and currents, 4 mm <sup>2</sup> terminals)	
Rated frequency $f_N$	50 Hz or 60 Hz
Rated current $I_N$	1 A, 2 A or 5 A
Thermal rating of current circuit continuous for 10 s for 1 s dynamic (half period)	$4 \times I_N$ $30 \times I_N$ $100 \times I_N$ $250 \times I_N$ (peak)
Rated voltage $U_N$	100 V or 200 V
Thermal rating of voltage circuit continuous during 10 s	$1.3 \times U_N$ $2 \times U_N$
Burden per phase current inputs at $I_N = 1$ A at $I_N = 5$ A voltage inputs at $U_N$	<0.1 VA <0.3 VA <0.25 VA
VT fuse characteristic	Z acc. to DIN/VDE 0660 or equivalent

**Table 2: Contact data**

Tripping relays	
No. of contacts	2 relays per I/O unit 316DB61 or 316DB62 with 2 N/O contacts each, 1.5 mm <sup>2</sup> terminals
Max. operating voltage	300 V AC or V DC
Continuous rating	5 A
Make and carry for 0.5 s	30 A
Surge for 30 ms	250 A
Making power at 110 V DC	3300 W
Breaking capacity for L/R = 40 ms Breaking current with 1 contact at U <50 V DC at U <120 V DC at U <250 V DC	1.5 A 0.3 A 0.1 A
Breaking current with 2 contacts in series at U <50 V DC at U <120 V DC at U <250 V DC	5 A 1 A 0.3 A
Signalling contacts	
No. of contacts	6, 10 or 8 acc. to I/O unit (316DB61, 316DB62 or 316DB63), 1 contact per sig. relay with 1.5 mm <sup>2</sup> terminals Each interface unit equipped with 1 C/O contact and the all others N/O contacts
Max. operating voltage	250 V AC or V DC
Continuous rating	5 A
Make and carry for 0.5 s	15 A
Surge for 30 ms	100 A
Making power at 110 V DC	550 W
Breaking current for L/R = 40 ms at U <50 V DC at U <120 V DC at U <250 V DC	0.5 A 0.1 A 0.04 A
The user can assign tripping and signalling contacts to protection functions	

Technical data hardware (cont'd)

**Table 3: Optocoupler inputs**

No. of optocouplers	8, 4 or 14 acc. to I/O unit (316DB61, 316DB62 or 316DB63)
Input voltage	18 to 36 V DC / 36 to 75 V DC / 82 to 312 V DC / 175 to 312 V DC
Threshold voltage	10 to 17 V DC / 20 to 34 V DC / 40 to 65 V DC / 140 to 175 V DC
Max. input current	<12 mA
Operating time	1 ms
The user can assign the inputs to protection functions.	

**Table 4: Light-emitting diodes**

Choice of display modes:	
<ul style="list-style-type: none"> <li>• Accumulates each new disturbance</li> <li>• Latching with reset by next pick-up</li> <li>• Latching <b>only</b> if protection trips with reset by next pick-up</li> <li>• Signalling without latching</li> </ul>	
Colors	1 green (standby) 1 red (trip) 6 or 14 yellow (all other signals)
The user can assign the LEDs to protection functions.	

**Table 5: Configuration and settings**

Local via the communication interface on the front port connector using an IBM-compatible PC with Windows NT 4.0 or Windows 2000. The operator program can also be operated by remote control via a modem.	
Operator program	in English or German

**Table 6: Remote communication**

RS232C interface Data transfer rate Protocol Electrical/optical converter (optional)	9 pin Sub-D female 9600 Bit/s SPA or IEC 60870-5-103 316BM61b
PCC interface Number	2 plug-in sockets for type III cards
PCC (optional) Interbay bus protocol Process bus protocol (interbay and process bus can be used concurrently) LON bus Data transfer rate	LON or MVB (part of IEC 61375) MVB (part of IEC 61375)  PCC with fiber-optical port, ST connectors 1.25 MBit/s
MVB bus  Data transfer rate	PCC with redundant fiber-optical port, ST connectors 1.5 Mbit/s
Event memory Capacity Time marker resolution	256 events 1 ms
Time deviation without remote synchronizing	<10 s per day
Engineering interface	integrated software interface for signal engineering with SigTOOL

**Table 7: Auxiliary supply**

Supply voltage	
Voltage range	36 to 312 V DC
Voltage interruption bridging time	>50 ms
Fuse rating	≥4 A
Load on station battery at normal operation (1 relay energized)	<20 W
during a fault (all relays energized)	
with 1 I/O unit	<22 W
with 2 I/O units	<27 W
with 3 I/O units	<32 W
with 4 I/O units	<37 W
Additional load of the options	
line differential protection (code SPxxx)	7.5 W
SPA, IEC 60870-5-103 or LON interface	1.5 W
MVB interface	2.5 W
Buffer time of the event list and fault recorder data at loss of auxiliary supply	>2 days (typ. 1 month)

**Table 8: General data**

Temperature range operation storage	-10°C to +55°C -40°C to +85°C	EN 60255-6 (1994), IEC 60255-6 (1988)
Humidity	93%, 40°C, 4 days	IEC 60068-2-3 (1969)
Seismic test	5 g, 30 s, 1 to 33 Hz (1 octave/min)	IEC 60255-21-3 (1995), IEEE 344 (1987)
Leakage resistance	>100 MΩ, 500 V DC	EN 60255-5 (2001), IEC 60255-5 (2000)
Insulation test	2 kV, 50 Hz, 1 min 1 kV across open contacts	EN 60255-5 (2001), IEC 60255-5 (2000), EN 60950 (1995)
Surge voltage test	5 kV, 1.2/50 μs	EN 60255-5 (2001), IEC 60255-5 (2000) *
1 MHz burst disturbance test	1.0/2.5 kV, Cl. 3; 1MHz, 400 Hz rep.freq.	IEC 60255-22-1 (1988), ANSI/IEEE C37.90.1 (1989)
Fast transient test	2/4 kV, Cl. 4	EN 61000-4-4 (1995), IEC 61000-4-4 (1995)
Electrostatic discharge test (ESD)	6/8 kV (10 shots), Cl. 3	EN 61000-4-2 (1996), IEC 61000-4-2 (2001)
Immunity to magnetic interfer- ence at power system frequen- cies	300 A/m; 1000 A/m; 50/60 Hz	EN 61000-4-8 (1993), IEC 61000-4-8 (1993)
Radio frequency interference test (RFI)	• 0.15-80 MHz, 80% amplitude modulated 10 V, Cl. 3 • 80-1000 MHz, 80% amplitude modulated 10 V/m, Cl. 3 • 900 MHz, puls modulated 10 V/m, Cl. 3	EN 61000-4-6 (1996) EN 61000-4-6 (1996), EN 61000-4-3 (1996), IEC 61000-4-3 (1996), ENV 50204 (1995)
Emission	Cl. A	EN 61000-6-2 (2001), EN 55011 (1998), CISPR 11 (1990)

\* Reduced values apply for repeat tests according to IEC publication 255-5, Clauses 6.6 and 8.6.

Technical data hardware (cont'd)

**Table 9: Mechanical design**

Weight Size N1 casing Size N2 casing	approx. 10 kg approx. 12 kg
Methods of mounting	semi-flush with terminals at rear surface with terminals at rear 19" rack mounting, height 6U, width N1: 225.2 mm (1/2 19" rack). Width N2: 271 mm.
Enclosure Protection Class	IP 50 (IP 20 if MVB PC cards are used) IPXXB for terminals.