

C7076A adjustable sensitivity ultraviolet flame detector

OPERATING INSTRUCTIONS

· Edition 08.22 · 95-8269 · EN



CONTENTS

1 Safety	1
2 Application	2
3 Checking the usage	2
4 Features	2
5 Technical data	2
6 Accessories	3
7 Replacement parts	3
8 Installation	3
9 Installing the detector	5
10 Wiring	6
11 Adjustments and checkout	8
12 Sensitivity adjustments	9
13 Troubleshooting	10
14 Service and Maintenance	11
15 Certification	14
16 Disposal	14

1 SAFETY

1.1 Please read and keep in a safe place

 Please read through these instructions carefully before installing or operating. Following the installation, pass the instructions on to the operator. This unit must be installed and commissioned in accordance with the regulations and standards in force. These instructions can also be found at www.docuthek.com.

1.2 Explanation of symbols

1, 2, 3, a, b, c = Action

→ = Instruction

1.3 Liability

We will not be held liable for damage resulting from non-observance of the instructions and non-compliant use.

1.4 Safety instructions

Information that is relevant for safety is indicated in the instructions as follows:

DANGER

Indicates potentially fatal situations.

WARNING

Indicates possible danger to life and limb.

CAUTION

Indicates possible material damage.

All interventions may only be carried out by qualified gas technicians. Electrical interventions may only be carried out by qualified electricians.

1.5 Conversion, spare parts

All technical changes are prohibited. Only use OEM spare parts.

2 APPLICATION

The C7076 adjustable sensitivity ultraviolet flame detector is a solid-state, adjustable sensitivity, device for sensing the ultraviolet radiation emanating from gas, oil and pulverized coal flames. It is designed for burner management and flame safety systems which require optimum sensitivity and/or flame discrimination.

3 CHECKING THE USAGE

Check the ratings given in the instructions and on the product to make sure the product is suitable for your application.

The C7076 features two sensitivity adjustments, each with a 400:1 dynamic range, and an integral flame signal meter jack to facilitate precise sighting.

The flame detector is designed for use with dynamic self-check ultraviolet amplifiers R7886 to provide a closed-loop, self-checking circuit which insures the integrity of both amplifier and flame detector. Improper response to simulated flame loss results in a safety shutdown and/or alarm.

This function is only guaranteed when used within the specified limits – see page 2 (5 Technical data). Any other use is considered as non-compliant.

3.1 Part designations

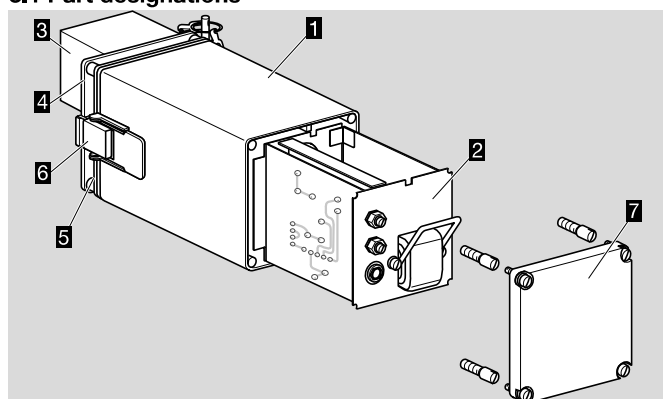

- 1 Housing
- 2 Plug-in Electronic Chassis
- 3 Aspirator
- 4 Faceplate-aspirator
- 5 Front cover plate
- 6 Latch
- 7 Rear cover

4 FEATURES

- High level output permits long distance transmission without special wiring.
- Solid state circuitry assures long life and stable sensitivity over wide ranges of temperature and voltage.
- Available in C7076A for use in standard installations.

5 TECHNICAL DATA

Models

C7076A—Adjustable sensitivity flame detector packaged in standard housing. Used with R7886 Dynamic Self-Check Ultraviolet Amplifiers.

Electrical ratings

Line voltage:

100 V AC, +10/-15%, 50/60 Hz;

120 V AC, +10/-15%, 60 Hz;

220/240 V AC, +10/-15%, 50/60 Hz

Power consumption:

Shutter voltage ¹⁾	max. power consumption ²⁾
100 V AC	7 W (14 VA)
120 V AC	7 W (14 VA)

1) Supplied by the appropriate flame safeguard control operating at the designated line voltage.

2) Does not include shutter power, which is supplied by the flame safeguard control.

Temperature ratings

Maximum aspirator temperature: 225 °F (107 °C).

Ambient operating temperatures: -40 °F to +160 °F (-40 °C to +71 °C).

→ Derate ambient temperature 1 °F for every 13 °F of aspirator temperature over 160 °F.

Sensitivity selection

Remote sensitivity selection: External switch can be wired to select the setting sensitivity control, either A or B.

External selector switch: Must rated for switching 20 mA at 48 V DC.

Sensitivity adjustment

Range: 400 to 1.

Sensitivity controls: Two, labeled A and B, on plug-in electronics chassis. Each can be set independently and locked to prevent drift due to vibration.

Flame signal amplifiers

R7886 Dynamic Self-Check Ultraviolet Amplifier; order separately.

Flame signal

Measured at flame current meter jack on C7076: 1.4 to 5.5 mA nominal.

Measured at flame voltage meter jack on R7886 amplifier: 0.0 to 5.0 V DC.

Shutter frequency

R7886: One test every 5 seconds to provide self-checking.

Pressure

C7076A quartz viewing lens: 20 psig (138 kPa) maximum.

Interchangeability

Model C7076A is not interchangeable with other flame detector models; it must be used with the R7886 Dynamic Self-Check Ultraviolet Amplifier.

Wiring Connections

Terminal block in front compartment of housing; wireclamp type, removable screws (terminal lugs can be used). Conduit fitting: 7/8 in. opening in housing to accommodate 1/2 inch flexible conduit; fitting must be water-tight to meet NEMA 4 standards.

Plug-in electronics chassis

Field-replaceable; plugs into octal socket in housing. Contains ultraviolet sensing tube, shutter assembly, power supply, solid state circuitry, sensitivity adjustment controls and flame current meter jack. Keyed to housing to ensure proper orientation.

Air flow requirements

Purge air: 0.7 SCFM (3.3 ml/sec) is required to maintain 4 inch (102 mm) of differential pressure from the aspirator inlet to the combustion chamber. An air flow of 3 SCFM (14 ml/sec) is recommended.

Seal-off air: 5 psig (34.5 kPa) maximum combustion chamber pressure.

Housing

Meets NEMA 4 standards (water-tight and dust-tight, indoor and outdoor).

Construction: Aluminum and cadmium-plated steel.

Color: Light blue.

Front compartment contains terminal block; rear compartment contains electronic chassis.

Weight

6.6 lb (3 kg).

5.1 Dimensions

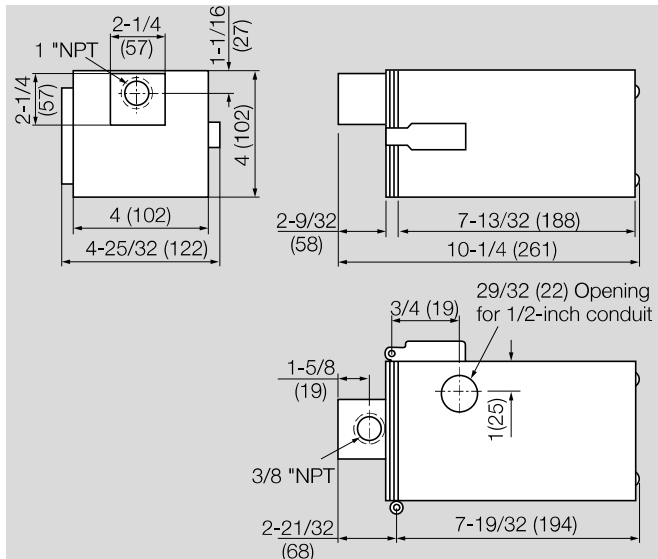

6 ACCESSORIES

117053 Meter Connector Plug (for older W136A models).

7 REPLACEMENT PARTS

The web app PartDetective for selecting spare parts is available at www.aclatus.org.

- 191002B Plug-in Electronics Chassis (without UV sensing tube).
- 190971E Coil and Shutter Assembly (for all models except 100V model).
- 190971F Coil and Shutter Assembly (for 100V model).
- 191053 Ultraviolet Sensing Tube.
- 191050 Viewing Lens.

8 INSTALLATION

8.1 Planning the installation

- Proper flame detector application is the basis of a safe and reliable flame safeguard installation.
- Refer to the burner manufacturer instructions as well as to those included here.
- Follow all instructions carefully.

8.2 Determine the location

Before beginning the actual installation, estimate the best location for mounting the detector based upon the following factors:

Temperature

- Install the flame detector where the surrounding temperature will remain within the specified ambient operating temperature ratings.
- For the C7076A, to keep the detector temperature within specifications, the aspirator temperature must not exceed 225 °F (107 °C). If the aspirator temperature will exceed temperature ratings, the introduction of cooling-purging air will be required.

Vibration

- Do not install the detector where it could be subjected to excessive vibration; it shortens the life of the electronic components. Vibrations with a magnitude greater than 1g will require an antivibration mount to cushion the detector.

Clearance

- Make sure there will be enough room to swing out the detector for servicing. Refer to Fig. 2 as applicable.

8.3 Installation position

Aspirator has 1-inch NPT tapping for mounting onto sight pipe, and 3/8 inch NPT tapping for connecting to the air supply. Detector mounts on aspirator by means of a removable piano-type hinge.

Allowable mounting positions

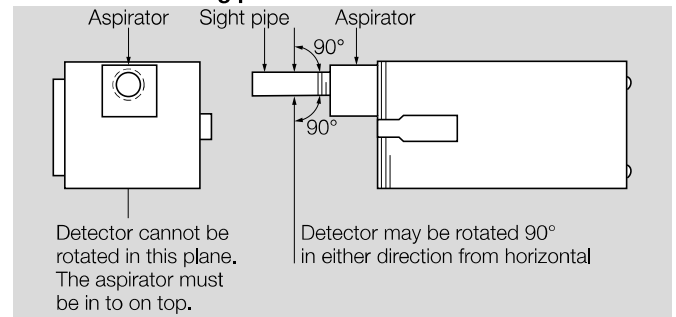

Mounting position

8.4 Radiation sources other than flame

Examples of radiation sources, other than flame, which could actuate the detector system include:

Ultraviolet sources

- 1 Radiant surfaces above 2200 °F (1200 °C).
- 2 Sparks from ignition transformers and welding arcs.
- 3 Gas lasers.
- 4 Sun lamps.
- 5 Germicidal lamps.
- 6 Incandescent lamps held close to the sensing tube (filament above 2200 °F [1200 °C]).

Gamma ray and X-Ray sources

- 1 Diffraction analyzers.
- 2 Electron microscopes.
- 3 Radiographic x-ray machines.
- 4 High voltage vacuum switches.
- 5 High voltage condensers.
- 6 Radioisotopes.

Except under very unusual circumstances, none of these sources, except a radiant surface or ignition spark, would be present in or near the combustion chamber.

The detector may respond to a radiant surface at a temperature above 2200 °F (1200 °C) if both of these conditions are present:

- The detector sensitivity control is set at (or near) maximum, and
- the surface represents a significant percentage of the detector field of view.

If the temperature or a radiant surface causes the flame relay (in the flame safeguard control) to pull in, re-aim the sight pipe so the detector views a cooler area, or decreases the sensitivity of the detector. Ignition spark is a rich source of ultraviolet radiation. When installing the detector, make sure it does not respond to ignition spark.

8.5 Single burner requirements

The detector must have an unobstructed view of a steady part of the flame it is supervising. This requires a proper sighting angle and minimized ultraviolet radiation attenuation effects. However, when supervising only one burner, sighting requirements are simplified.

8.6 Sighting angle

The first 30% of a flame closest to the burner nozzle (the flame root) emits the most ultraviolet energy. Also, if the detector sights the flame at an angle instead of perpendicularly, it views more flame depth. Therefore, the best sighting angle is nearly parallel to the axis of the flame, permitting the detector to view a large portion of the first 30% of the flame closest to the burner nozzle.

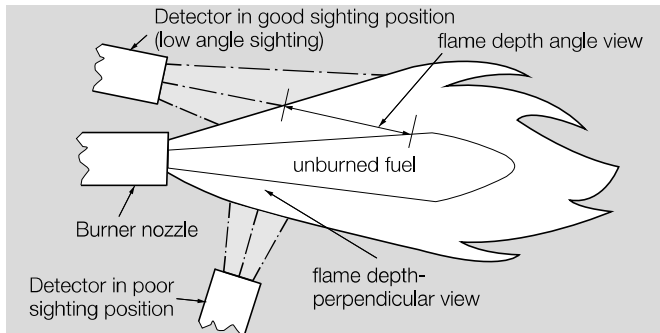

Detector sighting angle

Low angle sighting permits the detector to view a greater depth of flame, thus reducing the effects of instabilities in the flame pattern. Also, the environment near the burner nozzle is usually cleaner than at any other part of the combustion chamber. This provides a clearer line of sight and can keep the viewing window cleaner, thus reducing the maintenance required.

→ When possible, it is desirable to tilt the detector and sight pipe downward to prevent the buildup of soot in the pipe or on the viewing window.

In most installations, the detector needs to respond to the pilot flame alone, then the pilot and main burner flame together, and finally the main burner flame alone.

The detector must meet all sighting requirements that apply:

- Pilot flame alone: The smallest pilot flame that can be detected must be capable of reliably igniting the main burner.
- Pilot and main burner flame together: The detector must sight the junction of both flames.
- Main burner flame alone: The detector must sight the most stable part of the flame for all firing rates.

8.7 Screening effects

Smoke, fuel mist, dirt and dust are masking agents that absorb ultraviolet radiation from the flame. They create a screen that reduces the amount of ultraviolet radiation reaching the detector and may cause flame signal deterioration resulting in a shutdown. The adverse affects of screening may be minimized by proper burner adjustment, increasing the detector viewing area (shorten sight pipe and/or increase its diameter), and optimizing detector sensitivity.

8.8 Multiburner requirements (flame discrimination)

In addition to meeting the requirements for a single burner, a multiburner installation requires discrimination between flames. Flame discrimination can be defined as locating all flame detectors so that each detector responds only to the flame of the burner it is supervising. In multiple burner systems, not every detector can be positioned so its line-of-sight does not intercept flames from other burners. For example, this situation occurs in front-fired boiler-furnaces having more than one row of burners, or in multilevel opposed-fired furnaces where the burners face each other.

When planning such an installation, locate each flame detector so that it has the best possible view of the first 30% closest to the burner nozzle (the flame root) it is supervising, and the worst possible view of all other flames.

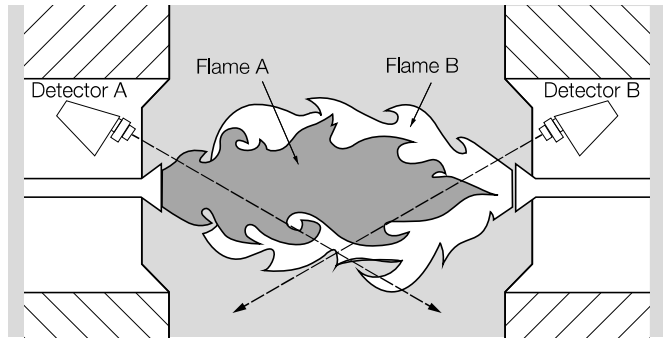

Example of flame discrimination problem (opposed fired burners).

This figure above illustrates a critical detector application problem that requires flame discrimination. Flame discrimination is accomplished for Detector A by repositioning it until the flame relay (in the flame safeguard control) does not respond to Flame B. Note that Detector A is aimed at the first 30% of Flame A where the ultraviolet radiation is most intense. It sights the tip of Flame B, but it is not aimed at the first 30% of Flame B where UV is intense. Detector A is repositioned to assure maximum response to Flame A while rejecting Flame B. Similarly, Detector B is positioned to assure maximum response to Flame B while rejecting Flame A.

If you reposition a detector and still cannot achieve flame discrimination, try reducing the viewing area by increasing the length or decreasing the diameter of the sight pipe, or adding an orifice plate.

8.9 Multifuel requirements

Detectors supervising burners that alternately fire more than one fuel may require a different sensitivity level for each fuel. For example, a higher sensitivity is required to reliably sense pulverized coal or No. 6 fuel oil in contrast to natural gas or to No. 2 fuel oil. Reliable flame sensing and flame discrimination may not be maintained simultaneously (without changing the sensitivity setting) when alternating between two fuels.

The C7076 has two integral sensitivity adjustments that can be remotely and automatically selected. The two sensitivity adjustments can be chosen by means of the fuel selector switch (refer to Remote Sensitivity Selection in the Installation section). The sensitivity adjustments should be made for both fuels as described in the section on multiburner requirements, using one adjustment pot for each fuel.

8.10 Parallel flame detectors

Two C7076 detectors can be connected in parallel to the same flame signal amplifier and still provide independent sensitivity adjustment. This capability is particularly useful for multiburner, multifuel applications.

Shifting flame patterns, commonly encountered on burners with wide turndown ratios, may require parallel detectors to prove the flame at the highest and lowest firing rates. In this case, one detector supervises the pilot (interrupted) and both detectors supervise the main burner flame. During the main burner run period, either detector is capable of maintaining system operation.

In addition to assuring more reliable flame detection, parallel detectors facilitate maintenance during burner operation. Each detector can be removed in turn without shutting down the supervised burner. However, a flame simulating failure occurring in the flame signal amplifier or in either detector will cause a shutdown.

8.11 Redundant Flame Detection System

Two C7076 detectors connected to two flame signal amplifiers wired in parallel comprise a redundant flame detection system. In addition to the features of parallel flame detectors, a redundant system increases reliability and is therefore recommended for critical burner applications. A flame failure, flame signal loss, or flame simulating failure occurring in either detector subsystem will cause an alarm (not a shutdown) allowing corrective action to avert a shutdown.

9 INSTALLING THE DETECTOR

9.1 When installing this product...

- Installer must be a trained, experienced, flame safeguard control technician.
- After installation is complete, check out product operation as provided in these instructions.

⚠ WARNING

Electrical shock hazard.

Can cause serious injury, death or equipment.

- Disconnect power supply before beginning installation to prevent electrical shock and equipment damage. More than one disconnect may be involved.
- All wiring must comply with applicable local electrical codes, ordinances and regulations.
- All wiring must be NEC Class 1 (line voltage).
- Voltage and frequency of the power supply connected to this detector must agree with the values marked on the detector.
- If an air supply is connected to the aspirator on the C7076A, its pressure must equal or exceed that required to seal off the detector from the combustion chamber.
- On multiburner installations, each detector must respond only to the flame(s) produced by the burner it is supervising.
- Do not connect more than two detectors in parallel to a single R7886 Dynamic Self-Check Ultraviolet Amplifier.
- Perform all required adjustments

9.2 Selecting and installing sightpipe

After you have determined the approximate location and sighting angle, select the sight pipe.

- A black iron pipe is recommended to provide reliable flame sensing. Stainless steel and galvanized pipes have bright surfaces that initially transmit ultraviolet radiation very well. However, their ability to transmit ultraviolet radiation will decay when the bright surfaces become dull with age or contamination, and flame detection will become less reliable with time.

The aspirator on the faceplate of the C7076A is tapped for a 1-inch NPT threaded pipe.

- A larger pipe may be necessary to obtain proper performance; an diameter other than 1 inch will require a reducer coupling. The geometry of the sight pipe affects the performance of the detector. If the flame signal is too small, reduce the length or increase the diameter of the pipe to increase the field of view of the detector. If a sight pipe longer than 1 foot is required, use a 2-inch diameter pipe with the reducer as close to the detector as possible.

- 1** Cut a hole of the proper diameter for the sight pipe in the burner front or windbox at the selected location. The hole should be at least 2 inches in diameter to allow adjustment of the sighting angle.
 - 2** If register vanes interfere with the desired line of sight, trim the interfering vane(s) to assure an unobstructed view of the flame.
 - 3** Cut the pipe to the desired length.
 - 4** Thread one end of the pipe to fit the desired mating component; i.e., reducer coupling, aspirator on the faceplate of the C7076A aspirator.
 - 5** Insert the other end of the pipe into the mounting hole, align it to the desired sighting angle, and tack weld it in position.
- When initially mounting the pipe, tack weld it in place to allow further sighting adjustments. Make sure the tack weld will support the weight of the detector when it is installed.
 - When installing a C7076A Detector, a Swivel Mount is recommended to facilitate sighting the flame properly.

9.3 Mounting the aspirator

The aspirator on the faceplate of the C7076A Detector screws directly onto the 1-inch NPT threaded pipe.

- 1** Remove the aspirator from the C7076A Detector by removing the hinge pin.
- 2** Use an adjustable wrench to tighten the aspirator onto the pipe.

- For alternate mounting methods and further information refer to figure below.

Installing the sight pipe for the C7076A detector

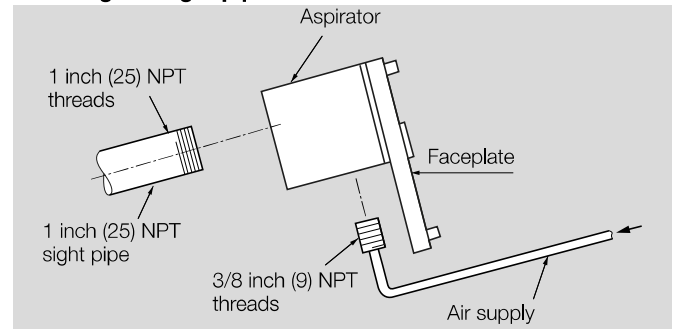

Direct mounting

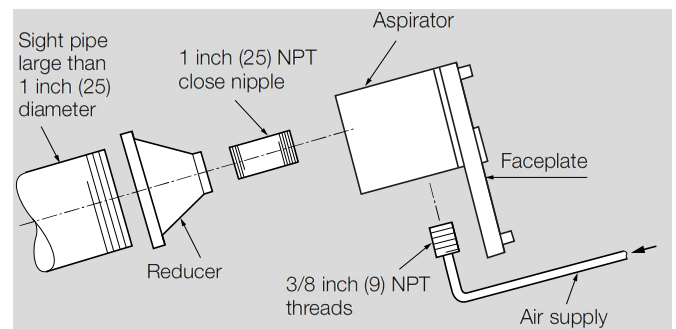

Using a reducer or larger pipes

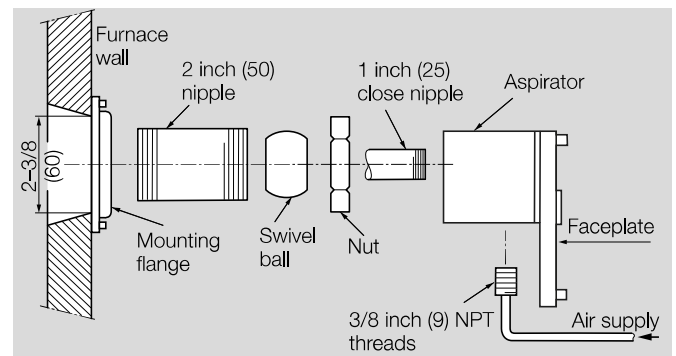

Using a swivel mount

9.4 Mounting the detector

- 1** Mount the detector on the faceplate by placing the detector on its hinge and re-inserting the hinge pin.
- Install 1/2 inch flexible conduit to the detector as follows:
 - 2** Loosen the four captive screws in the front coverplate (with the viewing lens) and remove the plate.
 - 3** Install a flexible conduit fitting in the opening in the bottom of the detector.

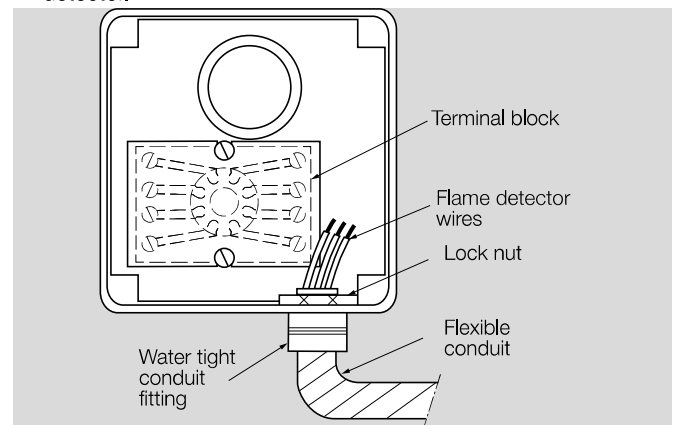

Connecting the watertight flexible conduit

- 4 To meet NEMA 4 standards, use watertight conduit and a watertight fitting (such as an Appleton ST50 Liquid-Tight Connector with an STG-50 Neoprene O-ring and steel gasket assembly). See table below for other applicable connectors.

Applicable watertight connectors.

Manufacturer	Coupling no.	O-Ring no.
T and B	5232	5262
Efcor	11-50	LTG-1
Raco	3402	2452
Steel City	LT-101	LR-531
Crouse Hines	LT-50	SG-1

9.5 Connecting air supply (optional)

- Use a flexible air supply line which will allow repositioning of the sight pipe until the permanent detector position has been verified.
- The aspirator air inlet can be plugged, left open, or connected to a clean (oil/moisture-free) air supply.
- Use a 3/8 inch NPT connector if aspirator air is used (see figures in page 5 (9.3 Mounting the aspirator)).
- The aspirator allows air to flow through the sight pipe into the combustion chamber to cool, clean and seal off the sight pipe.
- The airflow eliminates the need for frequent lens cleaning. See figure below for purge air requirements.

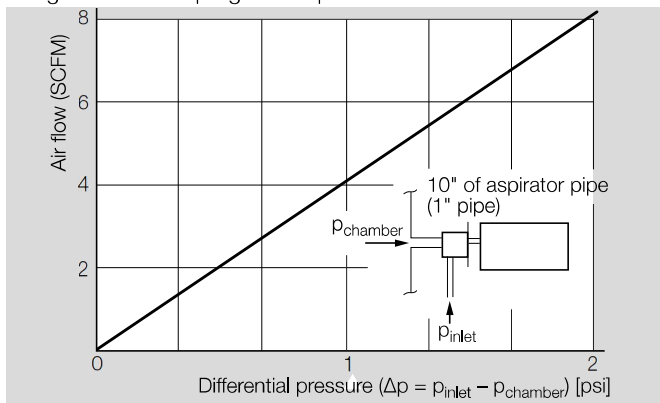

Purge air requirements

- Seal off of the sight pipe prevents hot gases from escaping from a positive pressure combustion chamber when the detector is swung open on its hinge for maintenance.
- Refer to figure below for the minimum inlet pressure or air flow required to seal off a sight pipe against a positive combustion chamber pressure.

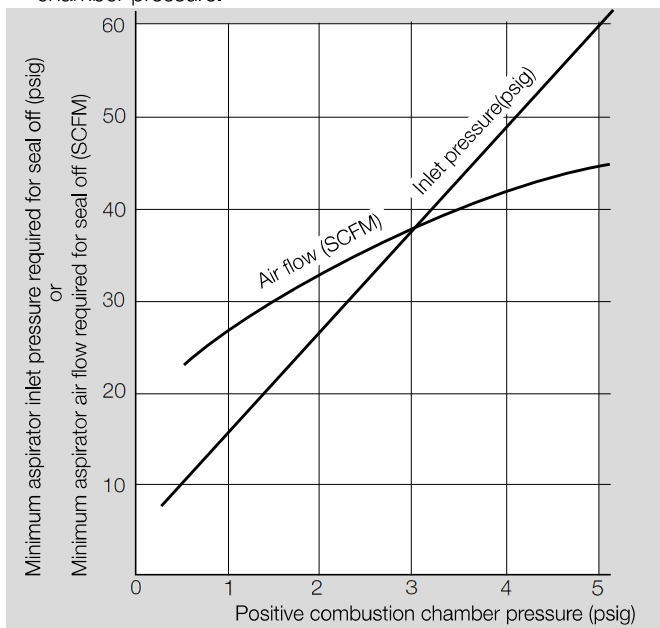

Minimum inlet pressure or airflow

- Next figure shows a method of supplying a constant airflow to purge the sight pipe, while also providing enough pressure to seal off the sight pipe when needed.

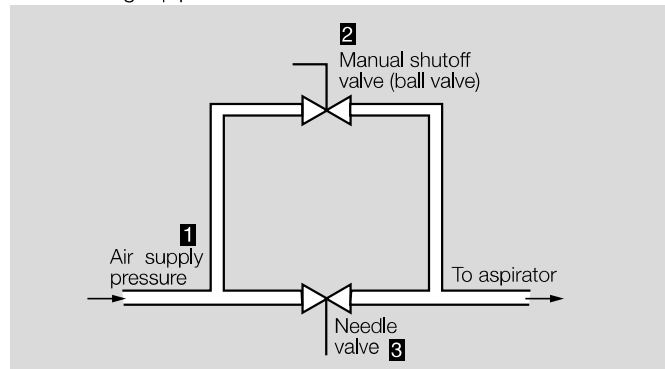

Supplying a constant airflow for purge

- 1 Equals or exceeds the pressure required to seal off the sight pipe from a positive pressure combustion chamber.
- 2 Open only when servicing the detector.
- 3 Adjust to provide enough air to cool the aspirator and maintain a clear sight pipe. Remove handle after adjusting.

9.6 Mounting preparation for wiring

- 1 Mount the detector on the faceplate and fasten in place using the four mounting screws supplied for this purpose.
- 2 Do not tighten the screws at this time, because the detector must still be wired.
- 3 Obtain a piece of conduit that is not longer than 18 inches in length and has 1/2-inch NPT threads at both ends.
- 4 Screw this piece of conduit into the threaded opening in the bottom of the detector housing.
- 5 Install an approved seal box on the other end of the piece of conduit and then complete the conduit installation as required.

10 WIRING

⚠ WARNING

Electrical shock hazard.

Can cause serious injury, death or equipment.

- Disconnect power supply before beginning wiring to prevent electrical shock and equipment damage. More than one disconnect may be involved.
- All wiring must comply with applicable local electrical codes, ordinances and regulations.
- All wiring must be NEC Class 1 (line voltage).

- The detector has color-coded and labeled, plastic-insulated no. 18 leadwires, 8 ft (2.4 m) long, rated for 221 °F (105 °C).

- 1 Keep the flame signal leadwires as short as possible from the flame detector to the terminal strip or wiring subbase. Capacitance increases with wire length, reducing the signal strength. the maximum permissible leadwire length depends on the type of leadwire and the conduit type and diameter. The ultimate limiting factor in flame signal leadwire length is the signal current or voltage at the flame safeguard device. See Electrical ratings, page 2 (5 Technical data).
- 2 Make required splices in a junction box. Detector leadwires can be spliced for longer leadwire runs observing the following considerations.
 - Use moisture-resistant no. 14 wire suitable for at least 167 °F (75 °C).
 - For High Temperature Installations, use Honeywell specification no. 32004766-003 or equivalent for the F leadwire. This wire is rated up to 480 °F (250 °C) for continuous duty. It is tested for operation up to 20,000 volts and for breakdown up to 35,000 volts. For the other leadwires, use moisture-resistant no. 14 wire selected for a temperature rating above the maximum operating temperature.

- F and G wires (blue and yellow) must be run in their own conduit, independent of other power-carrying leadwires. More than one scanner F and G wires can be run in the same conduit.
- A shielded twisted-pair wire may be substituted for using conduit for routing the F leadwire (blue). Be advised of the capacitance per foot of shielded wire effectively reduces the flame signal at the flame safeguard device. Be sure to ground the shield to the G terminal at the flame safeguard wiring subbase.
- The detector power and shutter wires need to be run in their own conduit, as well, avoiding other electrical noise-carrying wiring.
- The scanner wires should remain separated 2 inch (51 mm) minimum from other line voltage wires in the main control panel to the flame safeguard device.
- Installation considerations to be avoided that can influence detector operation and maximum leadwire length.
 - Moisture.
 - Ignition interference.
 - High resistance connections and poor grounds.
 - Leadwire capacitance.
 - Voltage fluctuations.
 - Induced line transients.
 - Floating grounds—ground at some voltage above earth ground.
 - No G wire—burner used as ground.
 - Detector output less than maximum attainable for the installation (inadequate sighting).

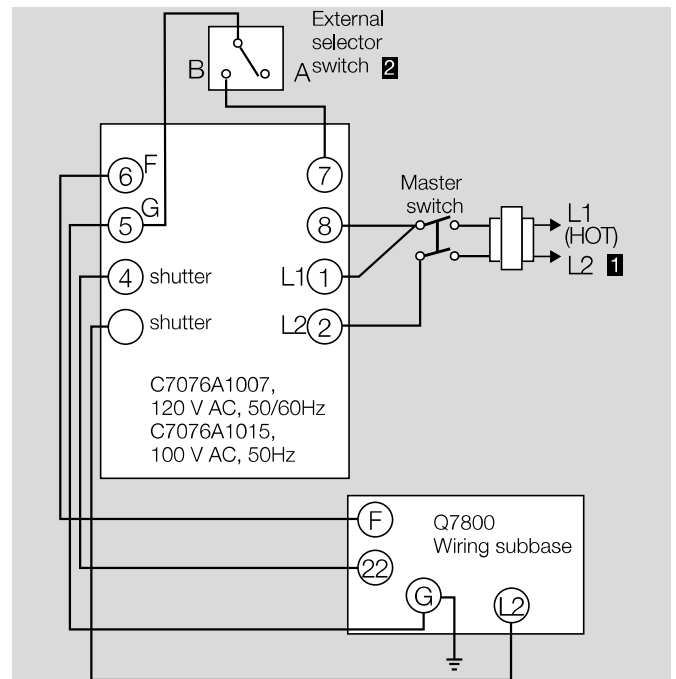

Wiring 120 V AC C7076A to RM78XX wiring sub-base.

1 Power supply. Provide disconnect mains and overload protection as required.

2 Optional SPST switch for remote sensitivity selection.

10.1 Remote system sensitivity

For systems firing more than one fuel, each with a different level of UV emission, or whose flame patterns change with firing rate, two sensitivity adjustments are provided. An external selector switch (spst) is required to choose between the two sensitivity settings. (Refer to Sensitivity Adjustments in the Adjustments and Checkout section.) With the external selector switch open, the A sensitivity control setting will determine the sensitivity of the detector; with the switch closed, the B setting will determine the sensitivity. For automatic sensitivity selection, the switch may be incorporated into the fuel selector switch or the firing rate switch.

10.2 Connecting detectors in parallel

Two C7076A flame detectors with the same voltage rating can be connected in parallel to the same terminals. To avoid exceeding the rating of the shutter control circuit, do not connect more than two detectors in parallel.

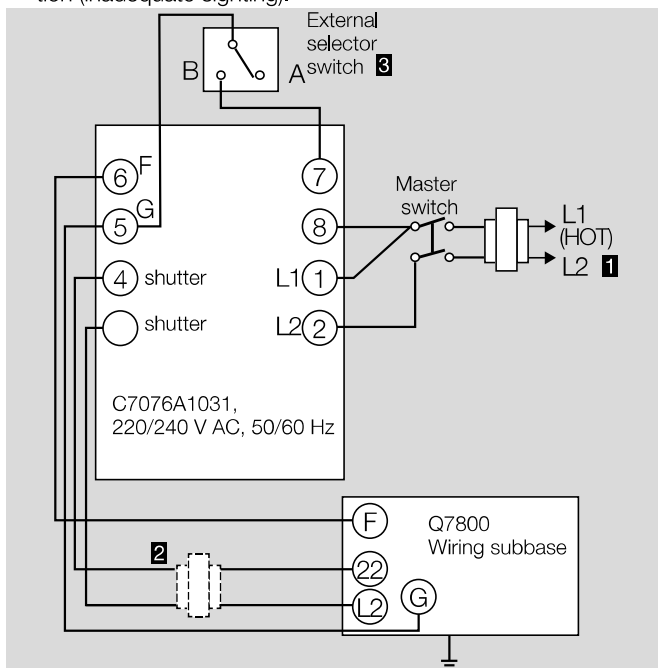

Wiring 220..240 V AC C7076A to EC78XX wiring sub-base.

1 Power supply. Provide disconnect mains and overload protection as required.

2 CAUTION When used with EC7800-series relay modules, to prevent damage to the shutter mechanism, install a 220/240 V AC to 120 V AC, 10 VA minimal step-down transformer to drive the shutter.

3 Optional SPST switch for remote sensitivity selection.

10.3 Making the connection

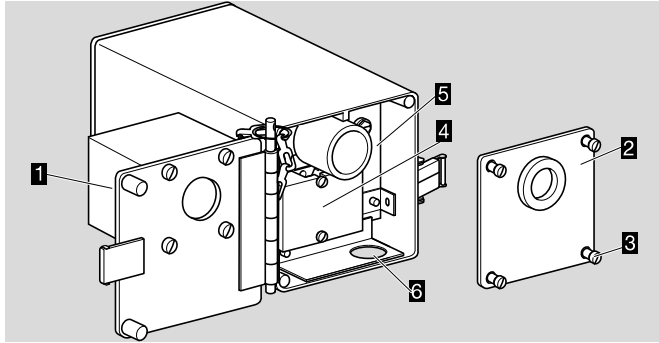

- 1 Faceplate-aspirator
- 2 Front cover plate
- 3 Captive screws
- 4 Terminal block
- 5 Face plate
- 6 Connection for conduit

Before connecting the lead wires to the octal connector receptacle block, completely remove the terminal block from the face plate to be able to reach the terminal screws. See description below.

- 1 Open the master switch to interrupt all power to the detector.
- 2 Unlatch the detector and swing it away from the faceplate-aspirator.

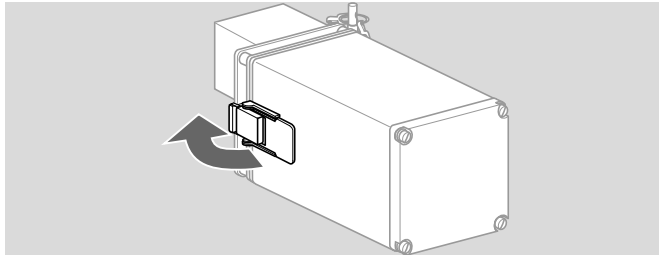

- 3 Loosen the four captive screws in the front cover plate (with the viewing lens) and remove the plate.

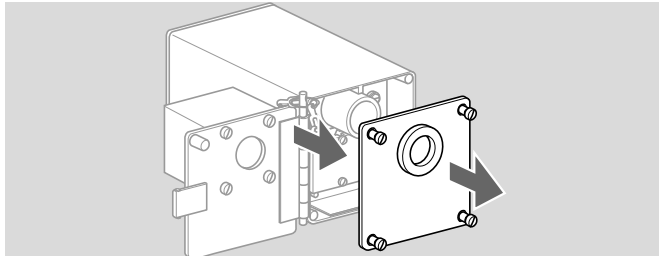

- 4 Remove the 2 screws that hold the terminal block to the face plate.

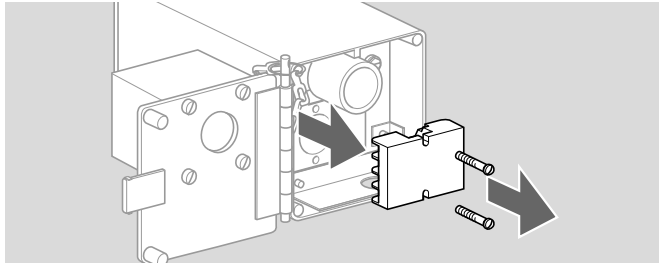

- 5 Run the wires from the flame safeguard control through the conduit to the terminal block.
 - 6 Connect each wire to the proper terminal. Make sure not to over-tighten the screws to avoid damaging the wire threads.
 - 7 Remount the wired terminal block on to the face plate.
- **IMPORTANT!** Make sure that the electrical insulation remains in the right place, to avoid short circuits against earth ground.
- 8 Reassemble the C7076 flame detector in the reverse order.

11 ADJUSTMENTS AND CHECKOUT

⚠ WARNING

Electrical shock hazard.

Can cause serious injury, death or equipment.

- Consult the burner/boiler manufacturer instructions and sequence of operation for the burner management system before initial burner lightoff.

11.1 Flame signal readings

The final sighting position of the C7076A detector may be most readily determined by using a test meter connected to the flame current meter jack on the plug-in electronics chassis. This output is the unprocessed flame signal from the detector and is intended as a diagnostic aid. Readings taken at the detector will facilitate installing the detector in the best sighting position by pinpointing the region of greatest UV intensity for a given flame.

Figure below illustrates the relationship between the detector and amplifier readings. Detector saturation (the point at which an increase in UV intensity does not produce a noticeable increase in flame signal strength) occurs at point A. Point B represents the point at which the amplifier is saturated while the minimum UV sensitivity required for system operation is at point C.

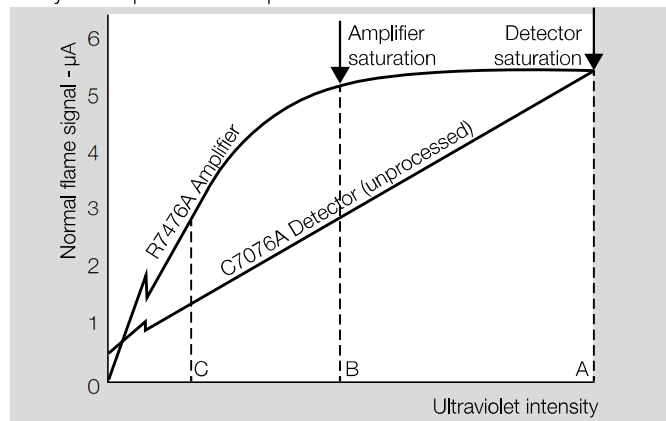

Comparison of UV intensity, amplifier saturation and detector saturation.

The linearity of the detector output curve shows that a unit increase in UV intensity is accompanied by a corresponding increase in flame signal strength. This condition facilitates pinpointing the location of the most intense UV radiating from a flame. Thus, by locating the optimum flame signal with the detector, the peak UV signal, and therefore the most reliable reading, is obtained.

The minimum acceptable stable flame signal readings are:

- C7076A flame detectors: 1.4 μA .
- R7886 Flame Signal Amplifier: 1.2 V DC.

12 SENSITIVITY ADJUSTMENTS

12.1 General considerations

- 1 If a single detector is required to supervise both the pilot and main burner flame, verify the flame signal for each flame individually.
- 2 Make sure the minimum acceptable stable flame signal (1.4 μA at the detector, or 1.2 V DC at the R7886 Amplifier) is obtained throughout the entire turndown range of the burner.
- 3 Parallel detectors may be required if a single sighting angle will not provide a proper flame signal for both the pilot and main burner flames throughout the entire turndown range of the burner.

12.2 Single Burner System Using the C7076A Detector

- 1 Loosen the four captive screws in the rear cover plate of the C7076A and remove the plate.
- 2 Adjust Sensitivity Control A for maximum sensitivity.

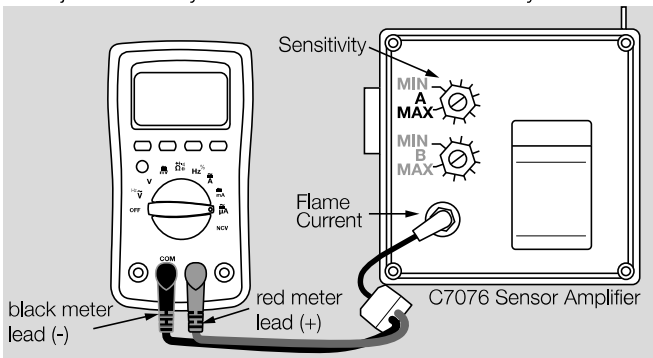

Set up for sensitivity controls A and B adjustments.

- a If the remote sensitivity selection feature is used, make sure the external selector switch is open for Control A adjustment.
 - b Loosen the setpoint locking nut on Sensitivity Control A.
 - c Turn the control clockwise to MAX position.
 - d Tighten the setpoint locking nut 1/4 turn past hand tight. Do not over-tighten.
- 3 Read the flame signal in μA at the Flame Current jack.
 - a Use a microammeter with a 0 to 25 μA DC range, shunted with a 50 microFarad capacitor, may be used.)
 - b A 117053 Meter Connector Plug is needed. Connect the red spade tip to the red (+) meter lead and the black spade tip to the black (-) meter lead.
 - c Insert the plug into the Flame Current meter jack and allow a few seconds for the meter reading to stabilize.
 - d Read the average stable current, disregarding the peaks due to shutter operation.
 - 4 Optimize the flame signal.
 - a Observe the flame signal while varying the line of sight of the detector:
Swivel the detector if it is mounted on a Swivel Mount, or
Adjust the angle and/or position the sight pipe (which was only tack welded as previously instructed).
 - b Try several sighting angles until you obtain the highest and most stable meter reading possible. (If it is less than 1.4 μA , refer to the Troubleshooting section.)
 - c Repeat step b for both the pilot and the main burner flame. Do not sacrifice the main flame signal to obtain an unnecessarily high pilot flame signal.
 - 5 Repeat steps 2 and 3 for Sensitivity Control B, if used.
 - 6 Make sure the external selector switch is closed while adjusting Control B.
 - 7 Secure the swivel mount (if used), or tack weld the sight pipe. Do not weld the sight pipe permanently into place until you have accomplished the spark hold-in and pilot turndown tests.
 - 8 Remove the plug from the Flame Current meter jack.
 - 9 Replace the rear cover plate and tighten the four screws securely.

12.3 Multiburner system using C7076A detector (flame discrimination)

- 1 Complete all steps under page 9 (12.2 Single Burner System Using the C7076A Detector) for each burner.
- 2 With all A sensitivity controls set to MAX position and all burners firing at full load, select one burner and proceed as follows.

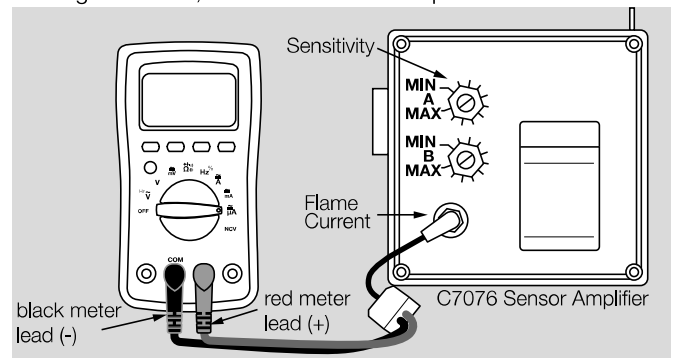

Set up for sensitivity controls A and B adjustments.

- a Shut down the chosen burner, then note the flame signal reading.
 - b Loosen the locking nut on Sensitivity Control A.
 - c Gradually reduce the sensitivity by turning Control A counterclockwise until the flame relay (in the flame safeguard control) drops out.
 - d Relight the burner and note the flame signal reading. The difference between the new reading and the initial reading in step a represents the degree of flame discrimination.
 - e Repeat the run-shutdown-dropout procedures (steps 2a-d) until the optimum setting has been achieved.
 - f Hand tighten the locking nut on Sensitivity Control A, then tighten another 1/4 turn, but do not over-tighten.
- If the sensitivity control on a detector is reduced to MIN position and flame discrimination cannot be achieved, insert an orifice plate in the sight pipe. An orifice of the proper diameter will reduce the ultraviolet radiation reaching the detector so that the sensitivity can be adjusted to effect flame discrimination.
- 3 Repeat step 2 for Sensitivity Control A on each burner.
 - 4 Repeat step 2 for Sensitivity Control B (if used) on each burner. Verify that Sensitivity Controls A and B on each detector are properly indexed by the system fuel selector, firing rate switch, etc.

12.4 Multifuel system

For multifuel systems, use one sensitivity control for each fuel. Follow steps 2 and 3 under page 9 (12.2 Single Burner System Using the C7076A Detector) for each fuel.

12.5 Ignition spark response test

An ignition spark response test must be done for all detectors to ensure that ignition spark will not actuate the flame relay in the flame safeguard control. The test is done by manually closing all fuel valves, starting the system, and observing the flame relay when the ignition comes on. If the flame relay pulls in, the detector must be repositioned to eliminate the response to ignition spark.

12.6 Pilot (Ignitor) turndown test

A pilot (ignitor) turndown test must be done for all applications in which the detector must prove the pilot before the main fuel valve can open. This test proves that the smallest pilot flame which can hold in the flame relay (in the flame safeguard control) is also capable of safely igniting the main burner. The test consists of closing the main fuel valve, reducing the pilot flame until it is just able to hold in the flame relay, and then opening the main fuel valve to verify a safe main burner lightoff.

12.7 Secure the sight pipe or swivel mount

- 1 When the flame signal is acceptable and all adjustments have been made, remove the detector.
- 2 Secure the sight pipe (or swivel mount): Weld the sight pipe in its final position, or Tack weld the swivel ball in place in its socket if using a Swivel Mount.
- 3 Reinstall the detector.

12.8 Aspirator adjustment

Make the final connections and adjustments of the optional air supply (if used). Refer to the paragraph page 6 (9.5 Connecting air supply (optional)).

12.9 Final checkout

- 1 Before placing the burner into service or after performing any service, repairs or maintenance, verify the installation using the procedures in the Checkout sections of the appropriate flame safeguard control.
- 2 After completing the checkout, run the burner through at least one complete cycle to verify correct operation.

13 TROUBLESHOOTING

13.1 General

⚠ WARNING

Electrical Shock hazard.

Can cause serious injury or death.

- Open the master switch to disconnect power before removing or installing the plug-in electronics chassis or the detector. Line voltage is present on some of the terminals when power is on.

If you cannot obtain a satisfactory flame signal while adjusting the sensitivity, refer to the preliminary and troubleshooting procedures that follow. If you encounter other problems in the system, refer to the Troubleshooting section in the instruction sheet for the appropriate flame safeguard control.

Upon completion of the troubleshooting, be sure to perform the adjustment and checkout procedures previously specified for the detector.

- Instructions for replacing the viewing lens, sensing tube, coil and shutter assembly and plug-in electronic chassis are given in the Service section.

Before making a replacement, make sure you have the correct part (check its part number and voltage rating).

13.2 Equipment required

- 1 Voltmeter with 0 to 300 V AC scale.
- 2 Microammeter with 0 to 25 μ A range, SPL damping.
- 3 Meter connector plug (Honeywell part no. 117053 or equivalent)—required for some meters.

For replacements see the web app PartDetective for selecting spare parts www.adlatus.org. or refer to page 3 (7 Replacement parts).

13.3 Preliminary procedures

IMPORTANT If the combustion chamber has a positive pressure, make sure the aspirator inlet pressure equals or exceeds that required for sight pipe seal off, as given in page 6 (9.5 Connecting air supply (optional)) on figure "Minimum inlet pressure or airflow", before unlatching the detector.

- 1 If you are using remote sensitivity selection, make sure that the external selector switch is open if adjusting Sensitivity Control A or closed if adjusting Sensitivity Control B.
- 2 Unlatch the detector and swing it away from the faceplate.
- 3 Loosen the four captive screws in the front cover plate (with the viewing lens) and remove the plate to expose the terminal block. The wiring diagram is on the inside of the front cover plate.
- 4 After each step in the following procedures, relatch the detector to the faceplate and check for a meter reading at the Flame Current jack on the detector.

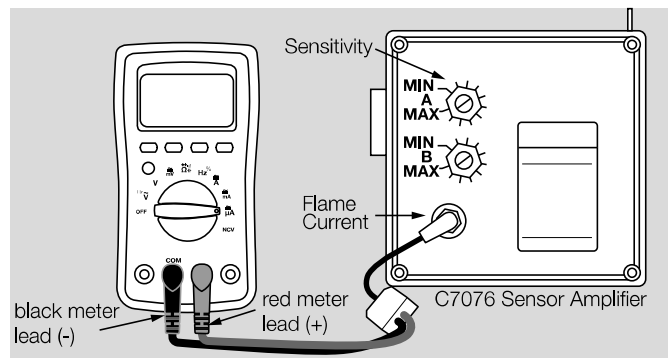

- a If you get a reading above 1.4 μ A and the flame relay (in the flame safeguard control) pulls in, return to Sensitivity Adjustments.
- b If you do not get a reading, unlatch the detector and proceed with Troubleshooting Procedure A, following.
- c If you get a reading but the flame relay (in the flame safeguard control) does not pull in, unlatch the detector and proceed with page 11 (13.5 Procedure B: Flame signal reading present at detector - flame relay does not pull in).

13.4 Procedure A: Zero flame signal reading at detector - Flame relay does not pull in

→ If the detector develops a signal at the Flame Current jack, skip troubleshooting Procedure A and refer to page 11 (13.5 Procedure B: Flame signal reading present at detector - flame relay does not pull in).

- 1 Complete the Preliminary Procedures listed above.
 - 2 Refer to the wiring diagram on the inside of the front cover plate for terminal locations or refer to the figures in page 6 (10 Wiring).
 - 3 Check for proper line voltage. Connect an AC voltmeter across terminals 2 and 1 (or 8, if detector is non-European 240 volt, 50/60 Hz model) on the terminal block. Make sure the AC voltage measured is within the voltage range listed in the table below, for the particular detector model used.
- The nominal voltage rating is printed on the transformer cover next to the sensitivity controls on the rear of the plug-in electronics chassis.
- a If there is no voltage, make sure line voltage power is connected to the master switch, the master switch is closed and overload protection (circuit breaker, fuse, or similar device) has not opened the power circuit.
 - b If the measured voltage is not within the proper voltage range, make sure the main power supply is of the correct voltage and frequency. Then trace the wiring between the detector and the main power supply to determine the problem.

Line voltage ratings for the detector

Nominal voltage rating	Acceptable line voltage	
	Min.	Max.
100	85	110
120	102	132
220	187	242
240	204	264

- 4 Determine if the self-checking shutter is open by looking into the front of the detector through the pipe in the wiring compartment.

Shutter voltage range

Nominal detector voltage range	Acceptable shutter voltage	
	Min.	Max.
100	85	110
120 or 220/240 V	99.5	132

- The nominal voltage rating is printed on the transformer cover next to the sensitivity controls on the rear of the plug-in electronics chassis.

a If the shutter is not open, connect an AC voltmeter across terminals 3 and 4 on the terminal block. Make sure the AC voltage measured is within the voltage range listed in the previous table "Shutter voltage range".

→ If the proper voltage is present, replace the coil and shutter assembly or the entire plug-in electronics chassis (see Service section).

→ If the measured voltage is not within the proper voltage range, connect a dc voltmeter (capable of measuring 50 volts) across terminals 6 (F) and 5 (G) on the terminal block (F is +, G is -)
-If the voltage is 2 volts or more, replace the plug-in electronics chassis (See Service section).
-If the voltage is less than 2 volts, trace the shutter wiring between the detector and the flame safeguard control (refer to the figures in page 6 (10 Wiring)). If the wiring is correct but the proper voltage is still not present, replace the plug-in R7886 Dynamic Self-Check Ultraviolet Amplifier.

b If the shutter is open, make sure the sensitivity control on the plug-in electronics chassis is not set too low for the flame conditions encountered. (Refer to page 8 (11 Adjustments and checkout).)

5 5. Make sure the viewing path is clear.

a Clean the sight pipe. Make sure there are no obstructions in it.

b Make sure the proper viewing lens is used.

→ Window glass does not transmit ultraviolet radiation. You can check for an improper lens by testing the detector with the lens removed.

c Clean the viewing lens with a soft, clean cloth.

6 If the previous actions have not corrected the problem, replace the 191053 Ultraviolet Sensing Tube (see service page 12 (14.3 Replacing the ultraviolet sensing tube)).

7 If you still do not get a meter reading, replace the plug-in electronics chassis.

13.5 Procedure B: Flame signal reading present at detector - flame relay does not pull in

1 Complete the Preliminary Procedures listed above.

2 Determine if the self-checking shutter is closed by looking into the front of the detector through the pipe in the wiring compartment.

3 If the shutter is closed and the signal at the Flame Current jack on the detector is 1 μ A or more, remove the ultraviolet sensing tube (see Service section) and operate the detector.

a If the shutter opens, replace the 191053 Ultraviolet Sensing Tube (see page 12 (14.3 Replacing the ultraviolet sensing tube)).

b If the shutter stays closed, replace the plug-in electronics chassis (see page 11 (14 Service and Maintenance)).

4 If the flame signal measured at the Flame Current jack on the detector is weak (less than 1.4 μ A), proceed as follows:

a Clean the sight pipe. Make sure there are no obstructions in it.

b Clean the viewing lens with a soft, clean cloth.

c Make sure the sensitivity control on the plug-in electronics chassis is not set too low for the flame conditions encountered. (Refer to page 8 (11 Adjustments and checkout).)

d Resight the detector. See page 3 (8.1 Planning the installation).

5 If the flame signal measured at the Flame Current jack on the detector is strong (greater than 1.4 μ A), but the flame relay does not pull in, connect a DC voltmeter (capable of measuring 50 volts) across terminals 6 (F) and 5 (G) on the terminal block (F is +; G is -).

a If the voltage is less than 5 volts and the shutter is not oscillating, disconnect the F leadwire from terminal 6 for a moment.
-If the voltage (5 to 6) rises, trace the wiring between the detector and the flame safeguard control (refer to the figures in page 6 (10 Wiring)). If the wiring is correct (no short circuits), replace the plug-in R7886 Dynamic Self-Check Ultraviolet Amplifier.
-If the voltage (F to G) does not rise, replace the plug-in electronics chassis (see page 11 (14 Service and Maintenance)).

b If the voltage is 5 volts or more, check the F and G leadwires between the detector and the flame safeguard control. If they are

wired properly (no open circuits), replace the plug-in R7886 Dynamic Self-Check Ultraviolet Amplifier.

6 If the previous actions have not corrected the problem, replace the plug-in electronics chassis.

14 SERVICE AND MAINTENANCE

⚠ WARNING

Electrical Shock hazard.

Can cause serious injury or death.

- Open the master switch to disconnect power before removing or installing the plug-in electronics chassis or the detector. Line voltage is present on some of the terminals when power is on.

⚠ WARNING

Fire or explosion hazard.

Can cause serious injury or death.

- Make sure that the environment surrounding the C7076 Flame Detector is free of all explosive or hazardous conditions before exposing the interior of the detector to the atmosphere during the performance of the following troubleshooting procedures.

IMPORTANT If the combustion chamber has a positive pressure, make sure the aspirator inlet pressure equals or exceeds that required for sight pipe seal off, as given in page 6 (9.5 Connecting air supply (optional)) on figure "Minimum inlet pressure or airflow", before unlatching the detector.

IMPORTANT Only qualified flame safeguard technicians should attempt to service or repair flame safeguard controls and burner management systems.

⚠ CAUTION

Equipment damage hazard.

Improper part replacement can damage the equipment.

- Before making a replacement, make sure you have the correct part (check its part number and voltage rating).

14.1 Periodic maintenance

1 Scheduled replacement of the detector components is not necessary.

2 Keep the flame detection system adjusted for safe and reliable operation

3 Clean the viewing lens regularly. Use a soft, clean cloth. If the lens is damaged, or if it is coated with a substance which cannot be cleaned off, replace it (see Maintenance Procedures, following).

4 Replace the silicone-rubber gaskets which seal the front and rear cover plates if they are damaged or deteriorated.