

ABB Drives

User's Manual

# Modbus Adapter Module RMBA-01

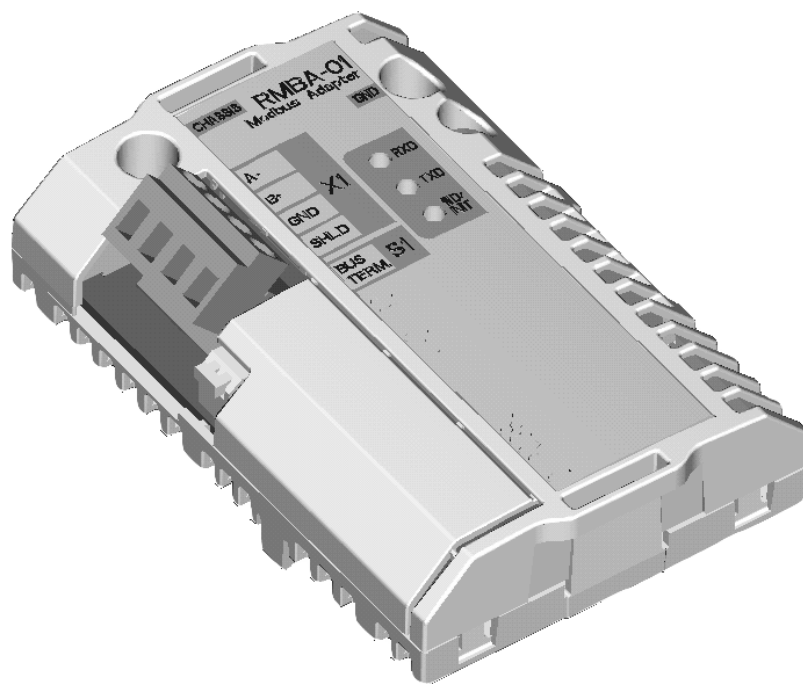

Modbus Adapter Module  
RMBA-01

**User's Manual**

3AFE 64498851 REV A EN

EFFECTIVE: 1.3.2002

# Safety instructions

---

## Overview

This chapter states the general safety instructions that must be followed when installing and operating the RMBA-01 Modbus Adapter module.

The material in this chapter must be studied before attempting any work on, or with, the unit.

In addition to the safety instructions given below, read the complete safety instructions of the specific drive you are working on.

## General safety instructions



**WARNING!** All electrical installation and maintenance work on the drive should be carried out by qualified electricians only.

The drive and adjoining equipment must be properly earthed.

Do not attempt any work on a powered drive. After switching off the mains, always allow the intermediate circuit capacitors 5 minutes to discharge before working on the frequency converter, the motor or the motor cable. It is good practice to check (with a voltage indicating instrument) that the drive is in fact discharged before beginning work.

The motor cable terminals of the drive are at a dangerously high voltage when mains power is applied, regardless of motor operation.

There can be dangerous voltages inside the drive from external control circuits even when the drive mains power is shut off. Exercise appropriate care when working on the unit. Neglecting these instructions can cause physical injury or death.

# Chapter 1 – Introduction

---

## ***Intended audience***

The manual is intended for the people who are responsible for commissioning and using a RMBA-01 Modbus Adapter module with the ACS 800 drive. The reader is expected to have a basic knowledge of electrical fundamentals, electrical wiring practices and how to operate the drive.

## ***Before you start***

It is assumed that the drive is installed and ready to operate before starting the installation of the extension module.

In addition to conventional installation tools, have the drive manuals available during the installation as they contain important information not included in this manual. The drive manuals are referred to at various points of this document.

**What this manual contains**

This manual contains information on the wiring, configuration and use of the RMBA-01 module.

**Safety instructions** are featured in the first few pages of this manual.

**Chapter 2 – Overview** contains a short description of the RMBA-01 Modbus Adapter module, a delivery checklist and warranty information.

**Chapter 3 – Installation** contains instructions for module hardware settings, mounting and cabling.

**Chapter 4 – Programming** explains how to program the master station and the drive before the communication through the adapter module can be started.

**Chapter 5 – Communication** contains a description of how data is transmitted through the RMBA-01 module.

**Chapter 6 – Fault tracing** explains fault tracing and the LED indications of the RMBA-01 module.

**Appendix A** contains technical data.

**Terms used in  
this manual**

<i>Parameter</i>	A parameter is an operating instruction for the drive. Parameters can be read and programmed with the drive control panel, or through the RMBA-01 module.
<i>Communication module</i>	Communication module is a parameter name/parameter selection name for a device (e.g. a fieldbus adapter) through which the drive is connected to an external serial communication network (e.g. a fieldbus). The communication with the communication module is activated with a drive parameter.
<i>RMBA-01 Modbus Adapter module</i>	The RMBA-01 Adapter module is one of the optional fieldbus adapter modules available for ACS 800 drives. The RMBA-01 is a device through which an ACS 800 drive is connected to a Modbus serial communication bus.
<i>Broadcast write</i>	Modbus network allows the Modbus master to perform a write to every slave station at the same time. This write is called Broadcast. This service does not give verification back to the master that the value has been received by each one of the slaves properly.
<i>4XXXX register area</i>	Modicon PLCs have a signed integer data table area, which is used for analogue output modules and for storing temporary or set-point values. These registers are in the address area starting from 40001. The last register address available on PLCs depends on the available memory, but is 49999 at most. The drive simulates this area by providing a read and write access to its parameters through this register address area.

## Chapter 2 – Overview

---

### **Overview**

This chapter contains a short description of the Modbus protocol and the RMBA-01 Modbus Adapter module, a delivery checklist, and warranty information.

### **Introduction to Modbus**

Modbus is a serial, asynchronous protocol. The Modbus protocol does not specify the physical interface. Typical physical interfaces are RS-232 and RS-485. The RMBA-01 provides a galvanically-isolated RS-485 interface.

Modbus is designed for integration with Modicon PLCs or other automation devices, and the services closely correspond to the PLC architecture. The RMBA-01 supports the RTU protocol only.

### **The RMBA-01 Modbus Adapter module**

The RMBA-01 Modbus Adapter module is an optional device for ABB drives which enables the connection of the drive to a Modbus system. The drive is considered as a slave on the Modbus network. Through the RMBA-01 Modbus Adapter module it is possible to:

- Give control commands to the drive (Start, Stop, Run enable, etc.)
- Feed a motor speed or torque reference to the drive
- Give a process actual value or a process reference to the PID controller of the drive
- Read status information and actual values from the drive
- Change drive parameter values
- Reset a drive fault

The Modbus commands and services supported by the RMBA-01 Modbus Adapter module are discussed in Chapter 5. Please refer to the user documentation of the drive as to which commands are supported by the drive.

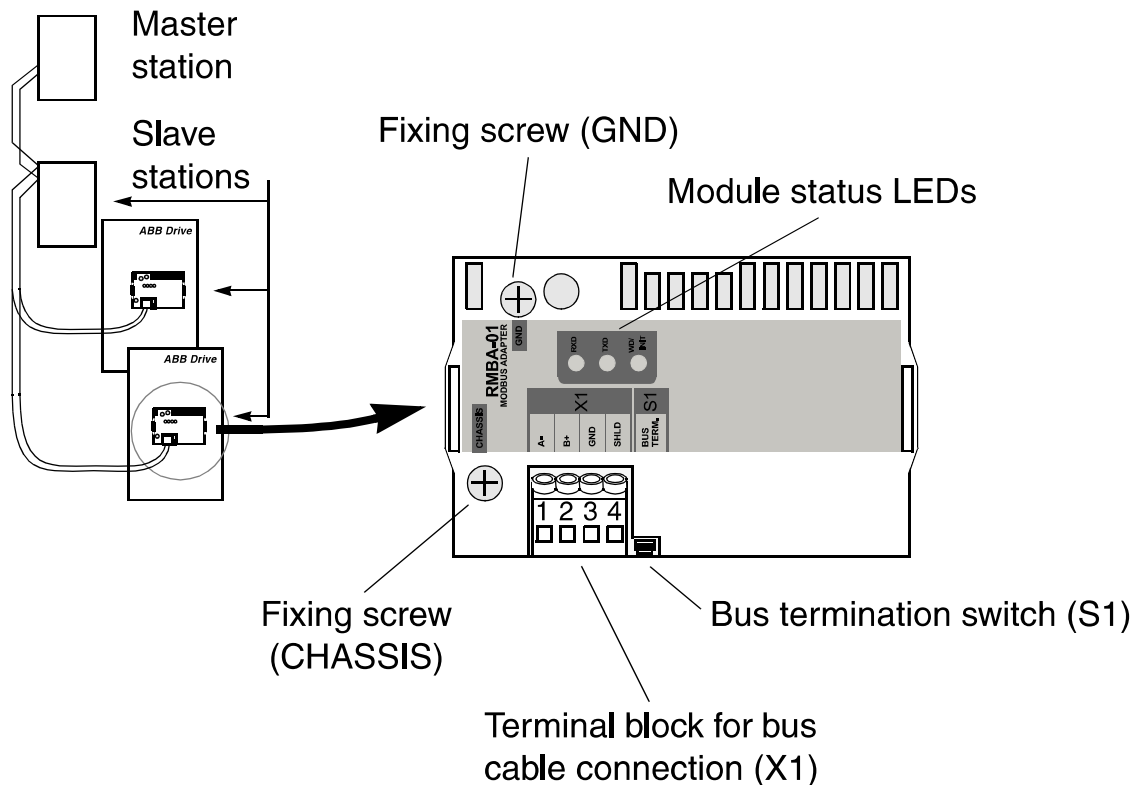

Figure 2-1 The construction of the Modbus link and the RMBA-01 Adapter module layout.

**Delivery check** The option package for the RMBA-01 Modbus Adapter module contains:

- RMBA-01 module
- Two screws (M3×8 mm)
- This manual.

**Compatibility** The RMBA-01 is compatible with ACS 800 Standard Application Program version ASXR7000 or later.

**Warranty and liability information**

The warranty for your ABB drive and options covers manufacturing defects. The manufacturer carries no responsibility for damage due to transport or unpacking.

In no event and under no circumstances shall the manufacturer be liable for damages and failures due to misuse, abuse, improper installation, or abnormal conditions of temperature, dust, or corrosives, or failures due to operation above rated capacities. Nor shall the manufacturer ever be liable for consequential and incidental damages.

The period of manufacturer's warranty is 12 months, and not more than 18 months, from the date of delivery. Extended warranty may be available with certified start-up. Contact your local distributor for details.

Your local ABB Drives company or distributor may have a different warranty period, which is specified in their sales terms, conditions, and warranty terms.

If you have any questions concerning your ABB drive, contact your local distributor or ABB Drives office.

The technical data and specifications are valid at the time of printing. ABB reserves the right to subsequent alterations.

## Chapter 3 – Installation

---



---

**WARNING!** Follow the safety instructions given in this guide and in the *ACS 800 Hardware Manual*.

---

### **Mounting**

The RMBA-01 is to be inserted into the position marked SLOT 1 on the drive. The module is held in place with plastic retaining clips and two screws. The screws also provide the earthing of the I/O cable shield connected to the module, and interconnect the GND signals of the module and the RMIO board.

On installation of the module, the signal and power connection to the drive is automatically made through a 38-pin connector.

The module can alternatively be mounted on a DIN rail-mountable AIMA-01 I/O Module Adapter (*not available at the time of publication*).

Mounting procedure:

1. Insert the module carefully into SLOT 1 on the RMIO board until the retaining clips lock the module into position.
2. Fasten the two screws (included) to the stand-offs.
3. Set the bus termination switch of the module to the required position.

---

**Note:** Correct installation of the screws is essential for fulfilling the EMC requirements and for proper operation of the module.

---

**Wiring**

See the *Hardware Manual* of the drive for cable routing information.

Arrange the bus cables as far away from the motor cables as possible. Avoid parallel runs. Use bushings at cable entries.

The terminal block (X1) on the RMBA-01 is of the detachable type for easy connection.

The Modbus cable shield may be directly earthed at one node only. At other nodes, the cable shield should be earthed via an RC circuit.

**Terminal designations**

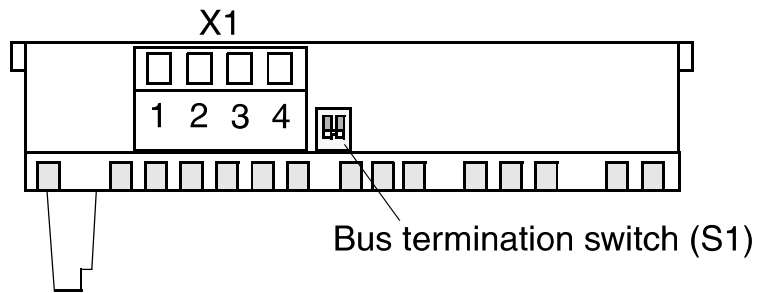

Figure 3-1 RMBA-01 terminal designations

X1	Marking	Description
1	A	Data negative (Conductor 1 in twisted pair).
2	B	Data positive (Conductor 2 in twisted pair).
3	DG	Data ground (Conductor 3 in a three-wire system). Used in a three-wire system as a common reference potential for all devices on the bus. Three-wire connection is highly recommended as it improves noise immunity. See the wiring diagrams below.
4	SHLD	Modbus cable shield AC earthing (via an RC circuit to the frame).

**Wiring Diagrams**

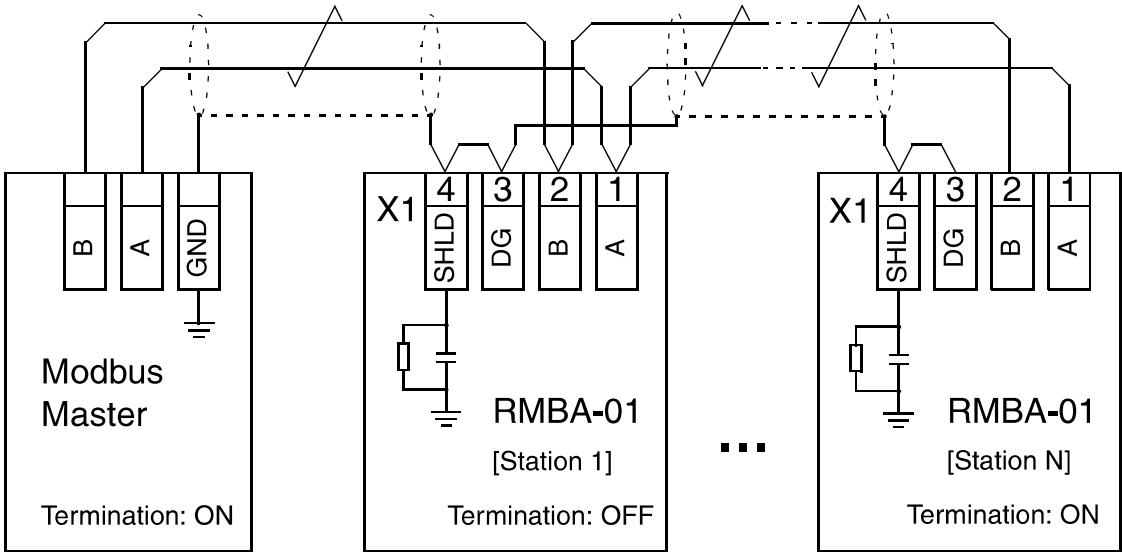

Figure 3-2 Two-wire connection

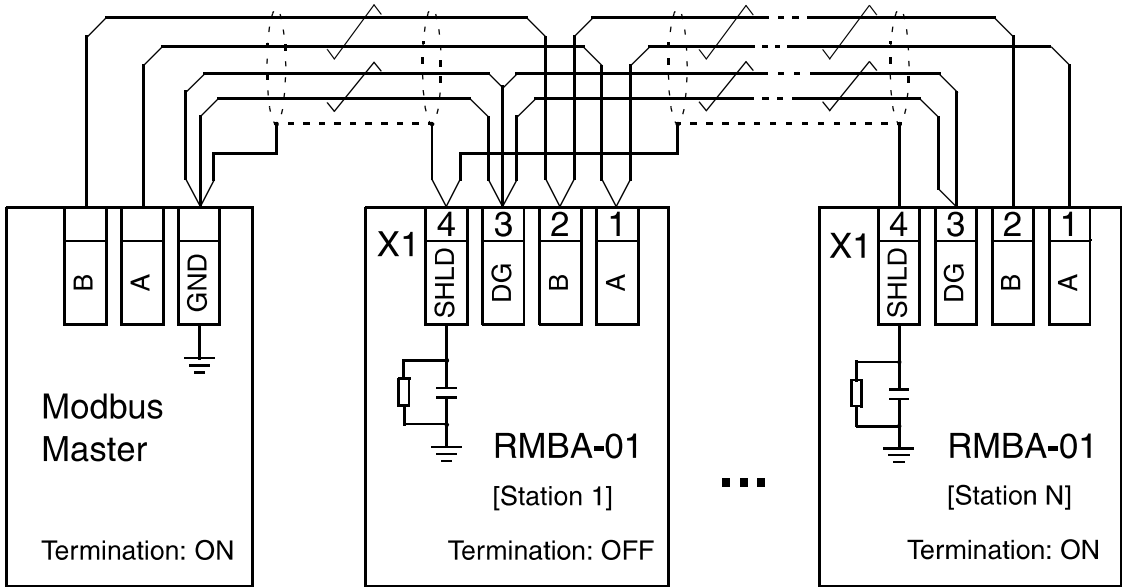

Figure 3-3 Three-wire connection (preferred practice)

**Bus termination** The built-in active bus termination must be switched on if the RMBA-01 module is installed at the end of the bus. Otherwise the bus termination must be switched off. Bus termination prevents signal reflections from the bus cable ends.

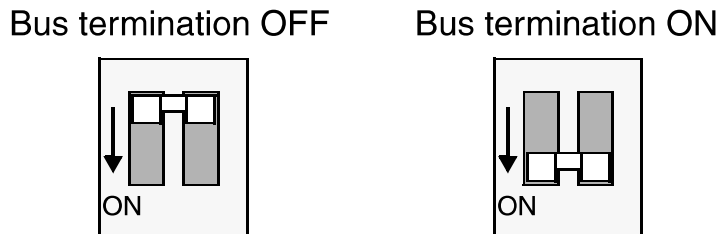

Figure 3-4 Bus termination switch (S1)

---

**Note:** The built-in termination circuitry of the RMBA-01 is of the active type, so the module has to be powered for the termination to work. If the module needs to be switched off during operation of the network, the bus can be terminated by connecting a 220 ohm, 1/4 W resistor between the A and B lines.

---

## Chapter 4 – Programming

---

### **Configuring the system**

After the RMBA-01 Modbus Adapter module has been mechanically and electrically installed according to the instructions in Chapter 3, the master station and the drive must be prepared for communication with the module.

Please refer to the master station documentation for information on configuring the system for communication with the RMBA-01.

### **Modbus connection configuration**

To establish communication between the RMBA-01 and the Modbus controller, the parameters in group 52 must be checked and adjusted where necessary (see the drive manuals).

The detailed procedure of activating the module for the control of the drive is described in the drive documentation.

### **Control locations**

ABB drives can receive control information from multiple sources including digital inputs, analogue inputs, the drive control panel and a communication module (e.g. RMBA-01). ABB drives allow the user to separately determine the source for each type of control information (Start, Stop, Direction, Reference, Fault Reset, etc.). In order to give the fieldbus master station the most complete control over the drive, the communication module must be selected as source for this information. See the user documentation of the drive for information on the selection parameters.

## Chapter 5 – Communication

---

### **Register read and write**

The drive parameter and data set information is mapped into a 4xxxx register area. This holding register area can be read from an external device, and an external device can modify the register values by writing to them.

There are no setup parameters for mapping the data to the 4xxxx register. The mapping is pre-defined and corresponds directly to the drive parameter grouping which is being used by the local drive panel.

All parameters are available for both reading and writing. The parameter writes are verified for correct value, and for valid register addresses. Some parameters never allow writing (e.g. actual values), some parameters allow writing only when the drive is stopped (e.g. setup variables), and some can be modified at any time (e.g. actual reference values).

### **Register mapping**

The drive parameters are mapped to the 4xxxx area such that:

- 40001 – 40096 are reserved for data sets.
- 40101 – 49999 are reserved for parameters.

In this mapping, the thousands and hundreds correspond to the group number, while the tens and ones correspond to the parameter number within a group. Register addresses 4GGPP are shown in [Table 5-1 Parameter mapping](#). In this table GG is the group number, and PP is the parameter number within the group.

Table 5-1 Parameter mapping

	<b>4GGPP</b>	<b>GG</b>	<b>PP</b>
<p>Data sets</p> <p>Each data set consists of 3 data words. For example, <i>Data word 2.3</i> refers to 3rd word in data set 2.</p>	<b>40001 – 40096</b>	<b>00</b> Data sets	<p><b>01</b> Data word 1.1  <b>02</b> Data word 1.2  <b>03</b> Data word 1.3  <b>04</b> Data word 2.1  <b>05</b> Data word 2.2  <b>06</b> Data word 2.3  <b>07</b> Data word 3.1  ...  <b>94</b> Data word 32.1  <b>95</b> Data word 32.2  <b>96</b> Data word 32.3</p>
Parameters	<b>40101 – 40199</b>	<b>01</b> Group 01	<p><b>01</b> Parameter 01  <b>02</b> Parameter 02  ...  <b>99</b> Parameter 99</p>
	<b>40201 – 40299</b>	<b>02</b> Group 02	<p><b>01</b> Parameter 01  <b>02</b> Parameter 02  ...  <b>99</b> Parameter 99</p>
	...	...	...
	<b>49901 – 49999</b>	<b>99</b> Group 99	<p><b>01</b> Parameter 01  ...  <b>99</b> Parameter 99</p>

The register addresses which are not allocated to any drive parameter or data set are invalid. No reads or writes are allowed for these addresses. If there is an attempt to read or write outside the parameter addresses, the Modbus interface will return an exception code to the controller.

Refer to the drive manuals for its data sets, group and parameter numbers supported.

**Exception codes** The RMBA-01 supports the Modbus exception codes shown in [Table 5-2](#).

*Table 5-2 Exception codes.*

Code	Name	Reason
01	ILLEGAL FUNCTION	Unsupported command.
02	ILLEGAL DATA ADDRESS	Address does not exist or is read/write protected.
03	ILLEGAL DATA VALUE	Value is outside min-max limits. Parameter is read-only.

### **Data update**

The RMBA-01 module has been designed for time-optimised, reliable data transfer between the Modbus network and the drive.

*Table 5-3 Function codes.*

Code	Name	Meaning
03	Read holding registers	Reads the binary contents of holding registers (4X references) in the slave.
06	Preset single register	Presets a value into a single holding register (4X reference). When broadcast, the function presets the same register reference in all attached slaves.
16 (10 hex)	Preset multiple registers	Presets values into a sequence of holding registers (4X references). When broadcast, the function presets the same register references in all attached slaves.

Data set registers are updated in a cyclic interval. Updating of parameter registers happens at a slower interval.

## Chapter 6 – Fault tracing

---

### ***Installation problems***

Verify all the connections on the module. Check that

- the Modbus cable is connected correctly to terminal block X1.
- the RMBA-01 module is correctly connected on the RMIO board using the fixing screws.

### ***Drive setup***

Drive parameters can be read, but control commands (Start/Stop or Reference) do not work.

- Activate the fieldbus module according to the instructions in the drive manual.
- Check that the drive has the Modbus Adapter selected as the source of these commands (see the *Firmware Manual* of the drive).

### ***PLC programming***

PLC program is beyond ABB support. Contact the manufacturer for assistance.

### **Diagnostic LEDs**

There are three diagnostic LEDs on the RMBA-01 module. Two green LEDs show the transmit and receive activity. A yellow LED shows the status of the module.

The RxD LED blinks every time a Modbus message is received by the RMBA-01 (independent of the node address setting). The TxD LED blinks every time the RMBA-01 sends a Modbus message over the bus.

The yellow LED lights at power-up and remains lit until the drive has configured the module. If the LED lights again after a successful configuration of the module, the module has gone to reset state due to e.g. power loss.

In case the LED does not go out after one second:

- The configuration has failed.
  - Switch off and restart the power supply of the drive.
- The module has a hardware failure.
  - Ensure the 38-pin connector is properly inserted.
  - Contact an ABB service representative.

## Appendix A – Technical data

---

### RMBA-01

#### Enclosure:

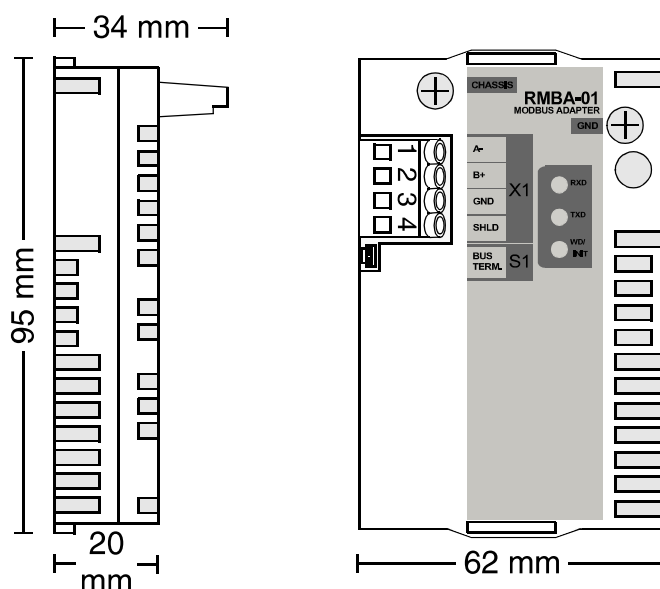

**Mounting:** Into an option slot of the RMIO board of the drive or onto external I/O Module Adapter (AIMA-01).

**Degree of protection:** IP 20

**Ambient conditions:** The applicable ambient conditions specified for the drive in its *Hardware Manual* are in effect.

#### Connectors:

- 38-pin parallel bus connector
- One 4-pole terminal block for connection of the fieldbus cable, detachable (max 1.5 mm<sup>2</sup>)

#### Hardware settings:

- One DIP switch for bus termination selection

**Settings:** Via drive interface (control panel)

**General:**

- Max. power consumption: 140 mA (5 V), supplied by the RMIO board
- Estimated min. lifetime: 100 000 h
- All materials UL/CSA-approved
- Complies with EMC Standards EN 50081-2 and EN 50082-2

**Fieldbus link**

**Compatible devices:** Any Modbus device capable of Modbus communication as a master

**Size of the link:** 247 stations including repeaters (31 stations and 1 repeater per segment)

**Medium:** Shielded, twisted pair RS485 cable

- Termination: built in, active type
- Modbus cable: Belden 9841 (2-wire), Belden 9842 (4-wire), or equivalent
- Maximum Bus Length: 1200 m

**Topology:** Multi-drop

**Serial communication type:** Asynchronous, half Duplex

**Transfer rate:** 600, 1200, 2400, 4800, 9600, 19200 bit/s

**Protocol:** Modbus RTU