

Gate Drive Amplifier/Interface Board IS200DAM_G_

Safety Symbol Legend



Warning

Indicates a procedure or condition that, if not strictly observed, could result in personal injury or death.



Caution

Indicates a procedure or condition that, if not strictly observed, could result in damage to or destruction of equipment.

Note Indicates an essential or important procedure or statement.

These instructions do not purport to cover all details or variations in equipment, nor to provide every possible contingency to be met during installation, operation, and maintenance. If further information is desired or if particular problems arise that are not covered sufficiently for the purchaser's purpose, the matter should be referred to GE Industrial Systems.

This document contains proprietary information of General Electric Company, USA, and is furnished to its customer solely to assist that customer in the installation, testing, operation, and/or maintenance of the equipment described. This document shall not be reproduced in whole or in part, nor shall its contents be disclosed to any third party without the written approval of GE Industrial Systems.

Section	Page
Functional Description	1
Application Data	2
DAMA, DAMB, and DAMC Indicators and I/O	4
DAMD Indicators and I/O	6
DAME I/O	7
Renewal/Warranty Replacement	8
How to Order a Board	8
Handling Precautions	9
DAMA, DAMB, and DAMC Board Replacement	10
DAMD Board Replacement	11
DAME Board Replacement	13

Functional Description

The Innovation Series™ 200DAM_ Gate Drive Amplifier and Interface boards (DAM_) provide an interface between the control rack and the power switching devices (IGBTs) of an Innovation Series low voltage drive. They include LEDs that indicate the IGBT on/off status (refer to tables in the *Application Data* section).

There are six variations of the gate drive boards, determined by the drive power rating (see *Application Data*, Table 1 for details):

DAMA	620 frame
DAMB	375 frame
DAMC	250 frame
DAMD	G1 for = 180 frame; G2 for 125 or 92 G2 frame
DAME	65 frame

The DAMA, DAMB, and DAMC boards amplify current to provide the final stage of gate drive for one phase leg of the drive's power bridge. They receive a +15/-7.5 power supply input. The DAMD and DAME boards provide an interface without amplification. They have no power input.

Mr. Lucian

Sales manager

Joyoung International Trading Co., Ltd

Whatsapp/Wechat: +86 18106906650

Email: Lily@htechplc.com

Mobile: +86 18106906650

Website: www.xm-dcs.com

Address: Room 1503, Building B, Diamond Coast,

No. 96 Lujiang Road, Siming District, Xiamen Fujian

Wechat



Application Data

Table 1 shows specifications for the DAM_ variations. The boards connect directly the IGBT gate, emitter, and collector terminals and to the control rack's IS200BPIA Bridge Personality Interface (BPIA) board, as shown in Figures 1 through 3. Refer to the sections below for I/O connector pin definitions and figures that show location of LEDs and connectors.

The boards contain no fuses, testpoints, or configurable items.

Table 1. DAM_ Board Variations and Application

Board	Frame	Powerrex IGBT	No. Boards per Drive	IGBTs per phase leg (3 phase legs per drive)
DAMA	620	CM1000HA-28H	3 (1 per phase leg)	1 single IGBT module for upper phase leg, 1 single IGBT module for lower phase leg.
DAMB	375	CM600HA-28H		
DAMC	250	CM400HA-28H		
DAMD G1	180	CM300DY-28H	3 (1 per phase leg)	One dual IGBT module per phase leg
DAMD G2	125 or 92	CM200DY-28H		
DAME	65	CM100TF-28H	1 (for all 3 phases)	1 IGBT module (6 IGBTs) for all 3 phases

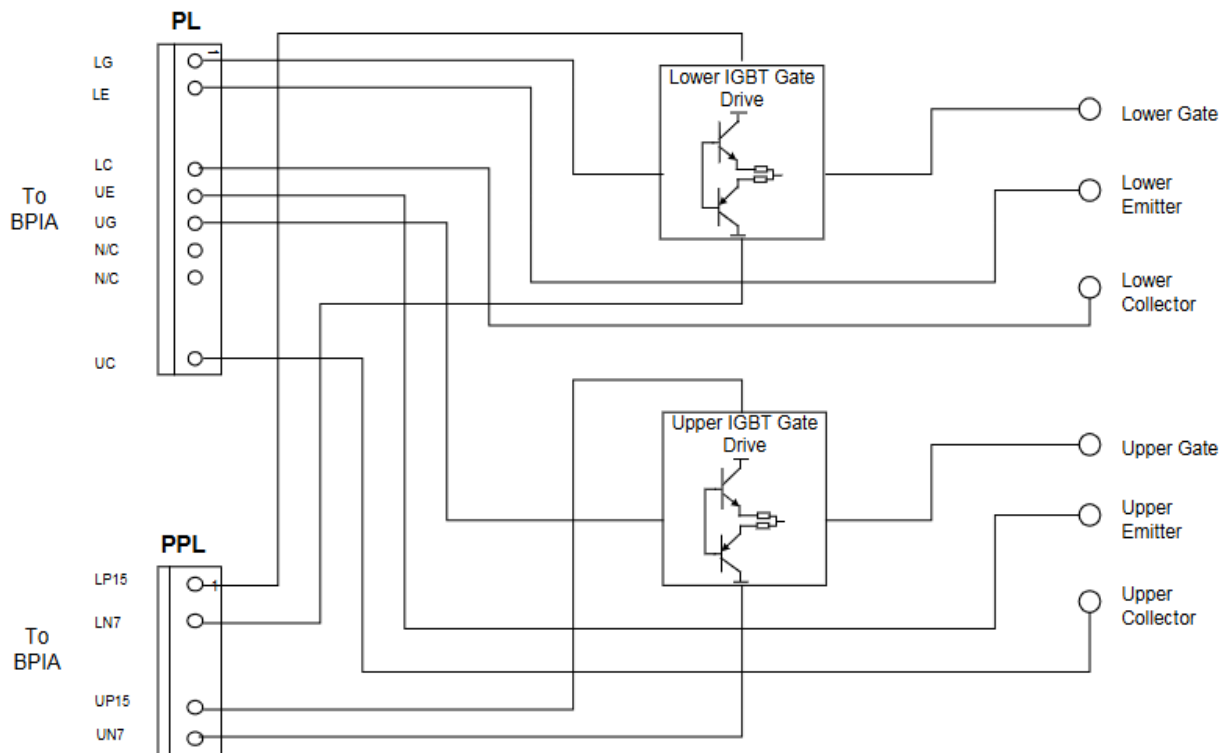

Figure 1. Gate Drive Amplifier Block Diagram (DAMA, DAMB, and DAMC Boards)

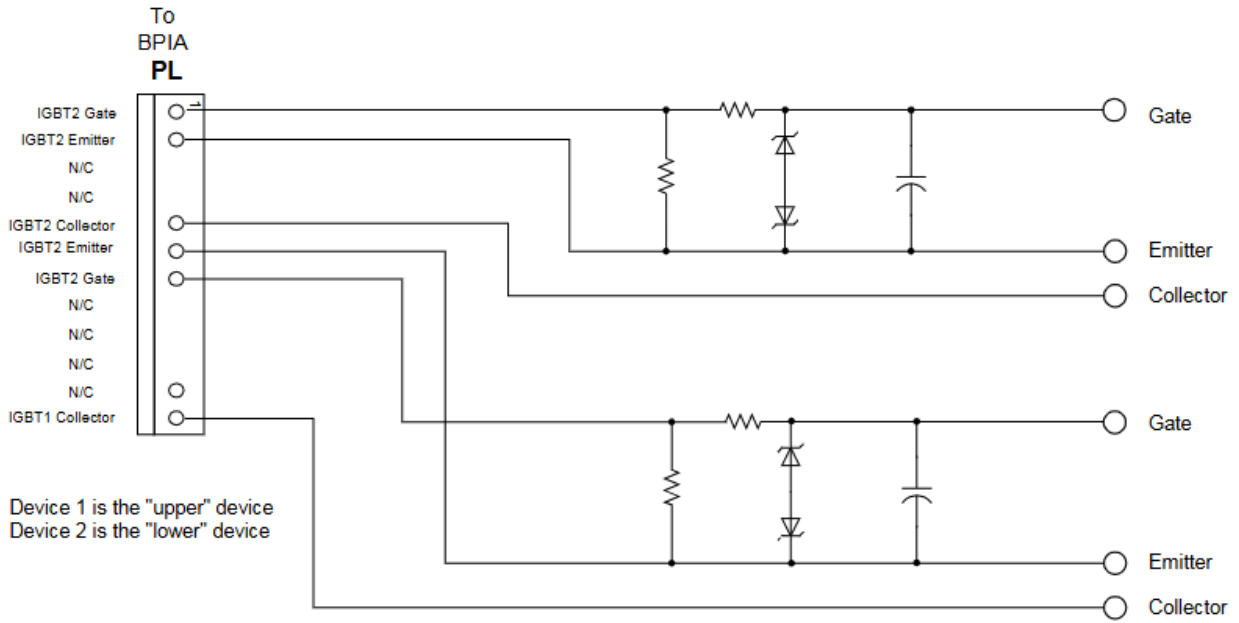

Figure 2. Gate Drive Interface Block Diagram (DAMD Board)

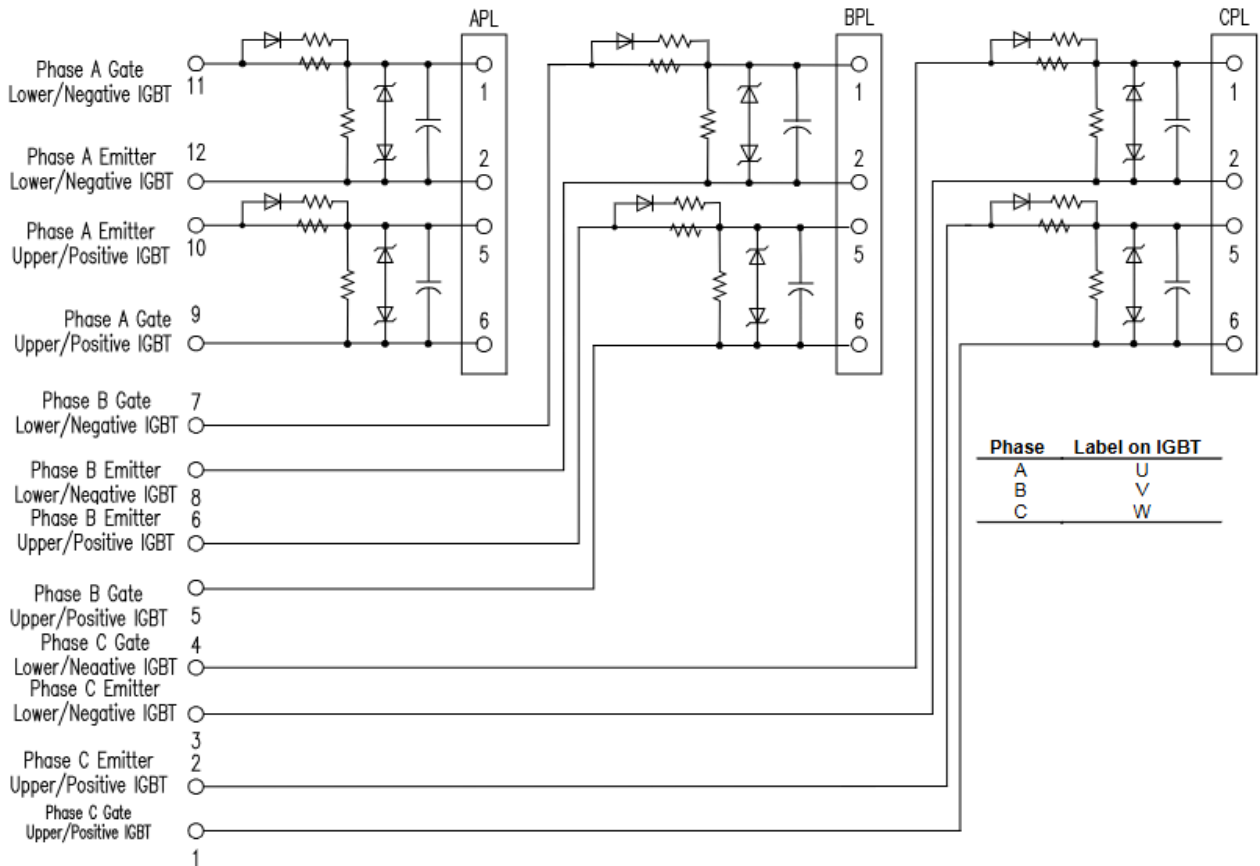

Figure 3. Gate Drive Interface Block Diagram (DAME Board)

DAMA, DAMB, DAMC Indicators and I/O

Table 2. DAMA, DAMB, and DAMC Board LED (IGBT Driver Monitors)

LED	Name	Color	Description
DS1	UON	Yellow	On when upper IGBT driven on
DS3	UFF	Green	On when upper IGBT driven off
DS2	LON	Yellow	On when lower IGBT driven on
DS4	LFF	Green	On when lower IGBT driven off

Table 3. DAMA, DAMB, and DAMC I/O, Connector PL (IGBT Connections)

Pin	Name	Description
1	GLIN	Lower gate signal
2	LCOM	Lower common signal (emitter)
3, 4, 8, 9	NC	Not connected
5	CL	Lower collector signal
6	UCOM	Upper common signal (emitter)
7	GUIN	Upper gate signal
12	CU	Upper collector signal

Table 4 DAMA, DAMB, and DAMC I/O, Connector PPL (Gate Drive Power Supply)

Pin	Name	Description
1	P15L	Lower gate driver +15 V dc power
2	N7L	Lower gate driver -7.5 V dc power
3, 4	NC	Not connected
5	P15U	Upper gate driver +15 V dc power
6	N7U	Upper gate driver -7.5 V dc power

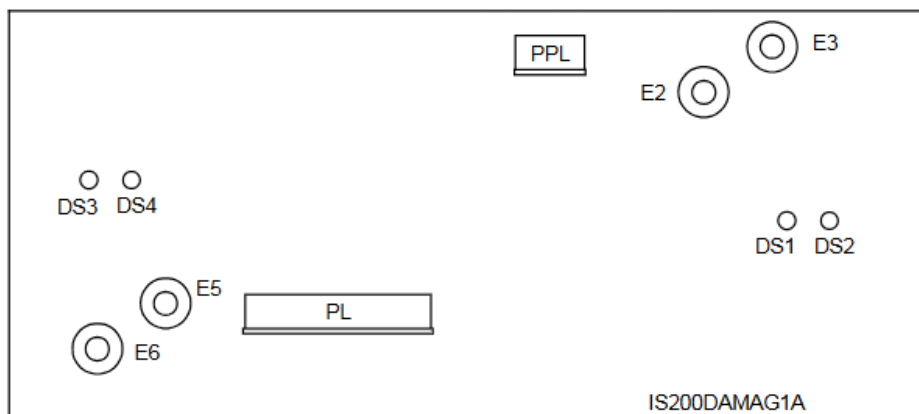

Figure 4. DAMAG1A Board Layout Diagram

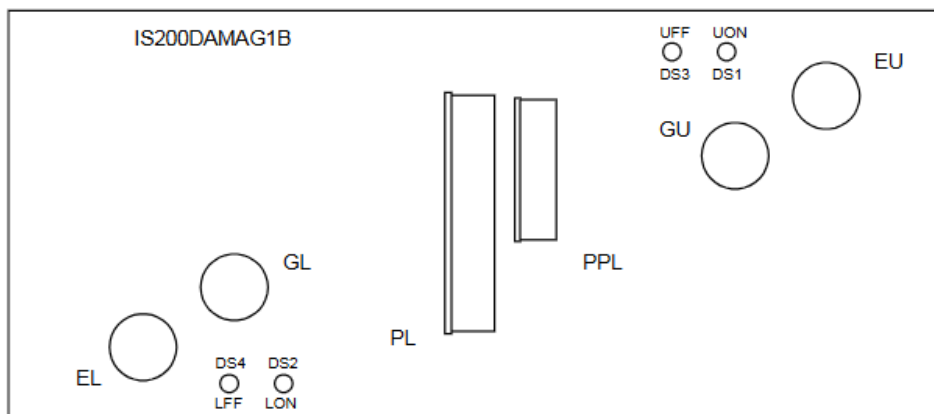

Figure 5. DAMAG1B Board Layout Diagram

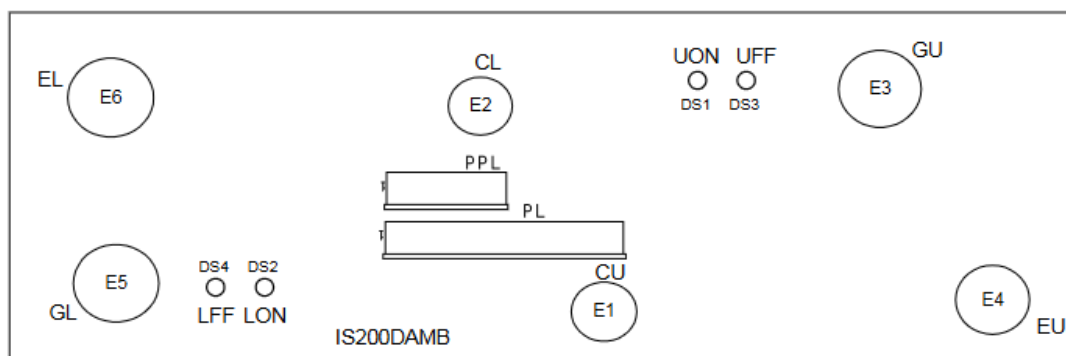

Figure 6. DAMB Board Layout Diagram

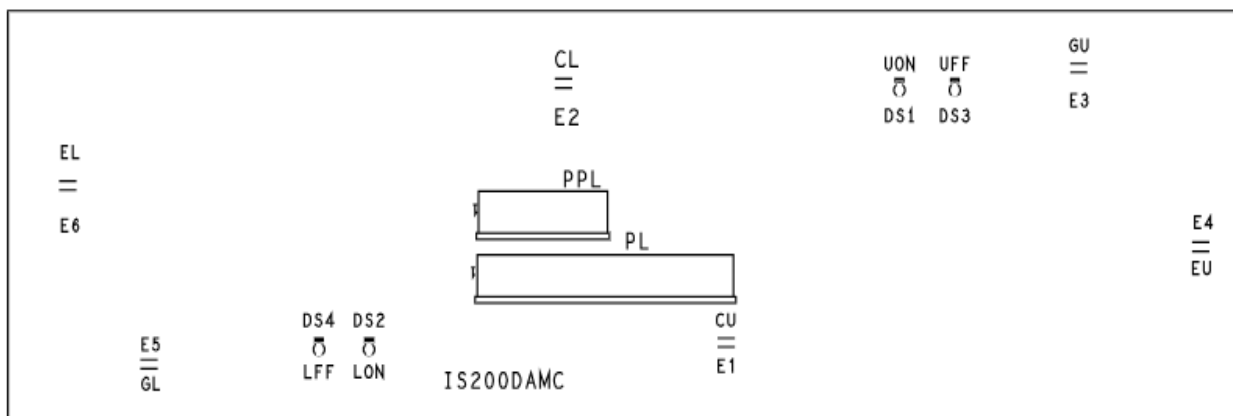

Figure 7. DAMC Board Layout Diagram

DAMD Indicators and I/O

Table 5 DAMD Board LED (IGBT Driver Monitors)

LED	Name*	Color	Description
DS1	1ON	Yellow	On when IGBT1 driven on
DS3	1FF	Green	On when IGBT1 driven off
DS2	2ON	Yellow	On when IGBT2 driven on
DS4	2FF	Green	On when IGBT2 driven off

*1 = Upper, 2 = Lower

Table 6 DAMD I/O, Connector PL (IGBT Connections)

Pin	Name*	Description
1	G2IN	Lower gate signal – IGBT2
2	COM2	Lower common (emitter of IGBT2)
3, 4, 8, 9, 10, 11	NC	Not connected
5	C2	Lower collector – IGBT2
6	COM1	Upper common (emitter of IGBT1)
7	G1IN	Upper gate signal – IGBT1
12	C1	Upper collector – IGBT1

*1 = Upper, 2 = Lower

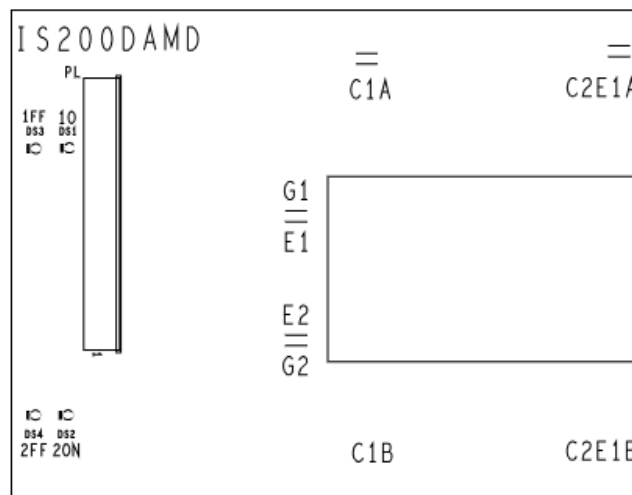

1 = upper, 2 = lower

Figure 8. DAMD Board Layout Diagram

DAME I/O

Note The DAME contains no LED indicators.

The DAME board contains three connectors (one per phase) for I/O with the BPIA board: APL for phase A, BPL for phase B, and CPL for phase C. Table 7 defines connector pin assignments. Figure 9 shows board layout.

Table 7 DAME I/O, Connector_PL (IGBT Phase _ Connections)*

Pin	Name	Description
1	G_N	Gate signal – phase _ * lower/negative IGBT
2	_NCOM	Common (emitter of Phase A* lower/negative IGBT)
3, 4	NC	Not Connected
5	_PCOM	Common (emitter of phase _ upper/positive IGBT)
6	G_P	Gate signal – phase _ upper/positive IGBT

*The underscore represents the phase.

Note On the IGBT, the three phases are marked as follows:
 Phase A = W
 Phase B = V
 Phase C = U

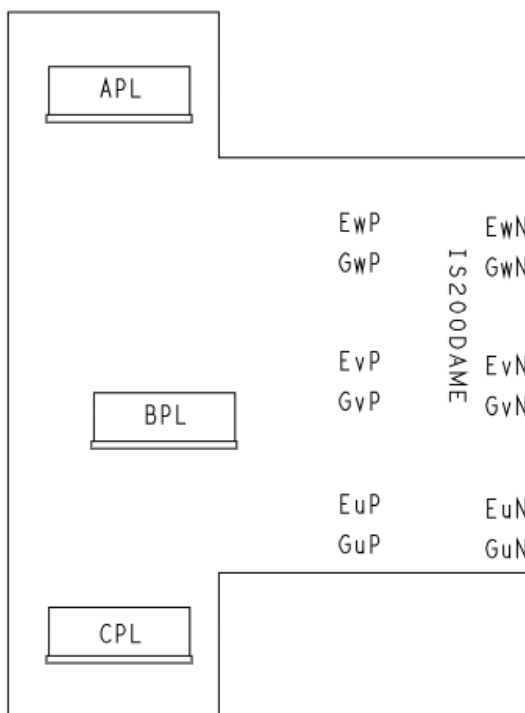

Figure 9. DAME Board Layout Diagram

Renewal/Warranty Replacement

This information helps ensure that GE can process the order accurately and as soon as possible.

How to Order a Board

When ordering a replacement board for a GE drive, you need to know:

- How to accurately identify the part
- If the part is under warranty
- How to place the order

Board Identification

A printed wiring board is identified by an alphanumeric **part (catalog) number** located near its edge. The following diagram explains the structure of the part number.

The board's functional acronym, shown in Figure 10, is normally based on the **board description**, or name. For example, the *DAMA* board is described as the *IGBT Gate Drive Amplifier board*.

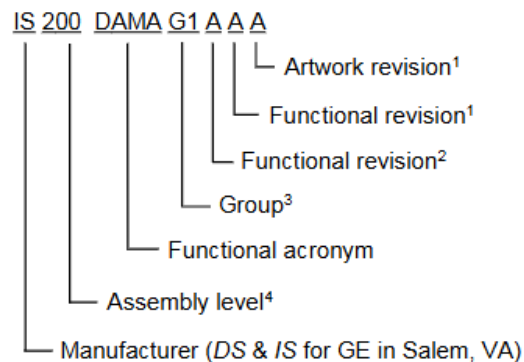

¹Backward compatible

²Not backward compatible

³G or H = group variation

⁴200 indicates a base-level board; 215 indicates a higher-level assembly or added components (such as PROM)

Figure 10. Board Part Number Conventions

Warranty Terms

The *GE Terms and Conditions* brochure details product warranty information, including **warranty period** and **parts and service coverage**. The brochure is included with customer documentation. It may be obtained separately from the nearest GE Sales Office or authorized GE Sales Representative.

Placing the Order

Parts still under **warranty** may be obtained directly from the factory:

GE Industrial Control Systems
Product Service Engineering
1501 Roanoke Blvd.
Salem, VA 24153-6492 USA
Phone: +1-540-387-7595
Fax: +1-540-387-8606

(^{“+”} indicates the international access code required when calling from outside of the USA.)

Renewals (spares or those not under warranty) should be ordered by contacting the nearest GE Sales or Service Office. Be sure to include:

- Complete part number and description
- Drive serial number

Note All digits are important when ordering or replacing any board. The factory may substitute later versions of boards based on availability and design enhancements. However, GE Industrial Systems ensures backward compatibility of replacement boards.

Handling Precautions



Caution

To prevent component damage caused by static electricity, treat all boards with static sensitive handling techniques. Wear a wrist grounding strap when handling boards or components, but only after boards or components have been removed from potentially energized equipment and are at a normally grounded workstation.

Printed wiring boards may contain static-sensitive components. Therefore, GE ships all replacement boards in antistatic bags. Use the following guidelines when handling boards:

- Store boards in antistatic bags or boxes.
- Use a grounding strap when handling boards or board components (per above *Caution* criteria).

DAMA, DAMB, and DAMC Board Replacement



Warning

To prevent electric shock, turn off power to the board, then test to verify that no power exists in the board before touching it or any connected circuits.



Caution

To prevent equipment damage, do not remove, insert, or adjust board connections while power is applied to the equipment.

Note If a DAMA/B/C board requires replacement, the IGBT module should also be replaced.

➤ **To remove the DAMA/B/C board**

1. Make sure that the drive in which the board resides has been deenergized.
2. Open the drive's cabinet door. Using equipment designed for high voltages, test any electrical circuits **before touching them** to ensure that power is off.
3. Locate the heatpipe heat exchanger assembly and the IGBTs with the DAMA/B/C boards mounted to them directly below.
4. Disconnect the cable from connector PL on the DAMA/B/C board to be removed and secure it out of the way.
5. Disconnect the cable from connector PPL on the DAMA/B/C board to be removed and secure it out of the way.
6. Remove two Keps® nuts securing the board. Loosen the four captive fasteners, and then slide the DAMA/B/C board off the IGBT stud connections.

➤ **To install the new (replacement) DAMA/B/C board**

1. Properly orient and place the new DAMA/B/C board over the IGBT stud connections, finger-tighten the four captive fasteners, and then install the two Keps nuts finger-tight.
2. Secure the new DAMA/B/C board by tightening each Keps nut to 13 inch-pounds torque. Then fully tighten the four captive fasteners.
3. Reconnect the cable to connector PPL on the new DAMA/B/C board.
4. Reconnect the cable to connector PL on the new DAMA/B/C board.
5. Visually inspect all connections, buses, and bolted hardware for correct installation.
6. Visually check the drive cabinet for any tools, debris, or other hardware that may be left in the drive.
7. Close the drive cabinet door.

DAMD Board Replacement



Warning

To prevent electric shock, turn off power to the board, then test to verify that no power exists in the board before touching it or any connected circuits.



Caution

To prevent equipment damage, do not remove, insert, or adjust board connections while power is applied to the equipment.

Note DAMD boards are soldered to the IGBT modules. When a board is replaced, it is replaced as a unit with the IGBT module.

➤ To remove the DAMD board and IGBT module

1. Make sure that the drive in which the board resides has been deenergized.
 2. Open the drive's cabinet door. Using equipment designed for high voltages, test any electrical circuits **before touching them** to ensure that power is off.
 3. Locate the heatpipe heat exchanger assembly and the IGBT modules with the DAMD boards mounted to them directly below.
 4. Disconnect the cable from connector PL on the DAMD board to be removed and secure it out of the way.
 5. Remove the three bolts, washers, and spring lock washers that secure the shunt board assembly to the IGBT module, allowing it to hang by the connected motor cables.
-



Caution

Do not allow the shunt board assembly to hang only from the control wires. If the motor cables are not connected, support the assembly by an auxiliary method.

6. Remove the three bolts, washers, and spring lock washers that secure the **outer** flex circuit and motor output bus bar.
7. Relocate the flex circuit and bus bar so they will not interfere with the DAMD board and IGBT module removal.
8. Repeat steps 6 and 7 for the **inner** flex circuit and motor output bus bar.
9. Remove the four Allen-head bolts and washers that secure the IGBT module to the heatsink. Remove the IGBT module.
10. Remove the two screws that secure the standoff to the DAMD board (for the shunt board assembly) and remove the standoff.

➤ **To install the new (replacement) IGBT module with DAMD board**

1. Using two screws, secure the standoff for the shunt board assembly to the new DAMD board and IGBT module. Tighten these screws.
2. Mount the new IGBT module with the DAMD board to the heatsink as follows:
 - a. Spread an even film of Dow Corning 340 silicon grease (or equivalent) onto the back mounting surface of the IGBT module (must be at least 6 mils thick).
 - b. Orient and position the IGBT module with DAMD board in the same position the as the one removed in the previous procedure, and insert the four Allen-head bolts and washers into the mounting holes.
 - c. Snug up the four bolts (in a diagonally crossing pattern; top left, lower right, top right, lower left).
 - d. Tighten the four bolts (in a diagonally crossing pattern, reversed from substep c) to 45 inch-pounds torque.
3. Reposition the **inner** flex circuit and motor output bus bar over the mounting holes. Secure with three bolts, washers, and spring lock washers.
4. Repeat step 3 for the **outer** flex circuit.
5. Reinstall the shunt board assembly to the IGBT module with three bolts, washers, and spring lock washers.
6. Reconnect the cable to connector PL on the new DAMD .
7. Visually inspect all connections, buses, and bolted hardware for correct installation.
8. Visually check the drive cabinet for any tools, debris, or other hardware that may be left in the drive.
9. Close the drive cabinet door.

DAME Board Replacement



Warning

To prevent electric shock, turn off power to the board, then test to verify that no power exists in the board before touching it or any connected circuits.



Caution

To prevent equipment damage, do not remove, insert, or adjust board connections while power is applied to the equipment.

Note DAME boards are soldered to the IGBT modules. When a board is replaced, it is replaced as a unit with the IGBT module (and vice versa).

➤ **To remove the DAME board and IGBT module**

1. Make sure that the drive in which the board resides has been deenergized.
2. Open the drive's cabinet door. Using equipment designed for high voltages, test any electrical circuits **before touching them** to ensure that power is off.
3. Locate the heatpipe heat exchanger assembly and the IGBT modules (with the DAME boards mounted to them) directly below.
4. Disconnect the cables from connectors APL, BPL, and CPL on the DAME board to be removed. Secure them out of the way.
5. Remove the three nuts, washers, and spring lock washers that secure the three shunt cables to the IGBT studs.
6. Relocate the three cables so they do not interfere with the DAME board and IGBT module removal.
7. Remove the two nuts, washers, and spring lock washers that secure the outer flex circuit to the IGBT studs.
 - Relocate the flex circuit so as not to interfere with the DAME board and IGBT module removal.
8. Remove the two nuts, washers, and spring lock washers that secure the inner flex circuit to the IGBT studs.
 - Relocate the flex circuit so as not to interfere with the DAME board and IGBT module removal.
9. Remove the four Allen-head bolts and washers that secure the IGBT module to the heatsink, and remove the IGBT module with board.
10. Remove the seven studs, washers, and spring lock washers from the IGBT module (that the shunt cables and flex circuit fasten to).

➤ **To install the new (replacement) IGBT module with DAME board**

1. Insert and fully tighten the seven studs, washers, and spring lock washers into the new IGBT module with DAME board. (Place the studs in the same respective positions from which they were removed.)
2. Mount the new IGBT module with DAME board to the heatsink as follows:
 - a. Spread an even film of Dow Corning 340 silicon grease (or equivalent) onto the back mounting surface of the IGBT module (must be at least 6 mils thick).
 - b. Orient and position the IGBT module with DAME board in the same position the as the one removed in the previous procedure and insert the four Allen-head bolts and washers into the mounting holes.
 - c. Snug up the four bolts (in a diagonally crossing pattern; top left, lower right, top right, lower left).
 - d. Tighten the four bolts (in a diagonally crossing pattern, reversed from substep c) to 40 inch-pounds torque.
3. Reposition the inner flex circuit onto the mounting studs and secure with two nuts, washers, and spring lock washers.
4. Reposition outer flex circuit onto the mounting studs and secure with two nuts, washers, and spring lock washers.
5. Reinstall the three shunt cables assembly to the IGBT module studs with three nuts, washers, and spring lock washers (removed in step 5).
6. Reconnect the respective cables to connectors APL, BPL, and CPL on the new DAME board.
7. Visually inspect all connections, buses, and bolted hardware for correct installation.
8. Visually check the drive cabinet for, and remove any tools, debris, or other hardware that may be left in the drive.
9. Close the drive cabinet door.