

**Siemens Moore
Process Automation, Inc.**

INSTALLATION AND SERVICE INSTRUCTION

SD39RIO-1
Rev: 1
January 2001

**APACS+™ and QUADLOG®
Remote I/O Rack
Installation and Service Instruction**

TABLE OF CONTENTS

<u>SECTION AND TITLE</u>	<u>PAGE</u>
1.0 Introduction	1-1
1.1 Product Description	1-1
1.2 Product Support	1-3
1.3 International Standards Organization (ISO) Symbols	1-5
1.4 Related Literature	1-6
2.0 Installation	2-1
2.1 Hardware Identification	2-1
2.2 Installation Considerations and Preparations	2-2
2.2.1 EMC Directive Installation Considerations	2-2
2.2.2 Preparation	2-2
2.2.3 Environmental Considerations	2-5
2.2.4 Equipment Delivery and Handling	2-5
2.2.4.1 Predelivery Inspection	2-5
2.2.4.2 Factory Shipment	2-6
2.2.4.3 Receipt of Shipment	2-6
2.2.4.4 Equipment Handling and Storage	2-6
2.3 Remote I/O Rack Mounting	2-6
2.4 APACS+ Cable Latching and Strain Relief Mechanisms	2-7
2.5 IOBUS Cable and Shunt/Jumper Connections	2-8
2.5.1 Standard IOBUS Cable Connections	2-10
2.5.2 IOBUS Cable Connection up to 300 ft. (91 m) for Redundant and Non-Redundant Systems	2-15
2.5.3 IOBUS Cable Connection up to 1500 ft. (460 m) for Non-Redundant APACS+ Systems Only	2-20
2.5.4 IOBUS Cable Connection up to 1500 ft. (460 m) for Rack-to-Rack Redundant APACS+ and All QUADLOG Systems	2-25
2.5.5 Modifying an IOBUS Cable	2-30
2.5.6 Remote I/O Rack IOBUS Shunt	2-31
2.5.7 IOBUS Attenuators	2-31
2.5.7.1 IOBUS Considerations for System Expansion	2-33
2.5.8 Setting OK Loop Jumpers W1 to W3	2-33
2.6 Rack Address Switch Setting	2-34
2.7 Slot Address Switch Setting	2-35
2.8 Recirculating Fan Power Cable Connection	2-36
2.9 DC Power Bus Connections	2-37
2.10 Terminal Block Connections	2-39
2.11 Protective Conductor Terminal Connection	2-39
2.12 IOBUS Cable Installation	2-40
2.13 Module and Rack Keying.....	2-41

TABLE OF CONTENTS (Continued)

<u>SECTION AND TITLE</u>	<u>PAGE</u>
3.0 Maintenance	3-1
3.1 Visual Inspection	3-1
3.2 Cleaning	3-1
3.3 Parts Replacement	3-1
3.3.1 Fan Fuse Replacement	3-1
3.4 Recommended Spare and Replacement Parts	3-2
3.5 Return of Equipment Within North America	3-2
3.6 Return of Equipment Outside North America	3-2
4.0 Circuit Description	4-1
4.1 Communications	4-1
4.2 IOBUS Signals	4-1
4.3 DC Power Bus	4-2
5.0 Accessories, Attachments, and Options	5-1
5.1 Accessories	5-1
5.2 Attachments	5-1
5.3 Options	5-1
6.0 Specifications	6-1
6.1 Mechanical Specifications	6-1
6.2 Environmental Specifications	6-1
6.3 Electrical Specifications	6-2
6.4 Electrical Classification	6-3
6.4.1 Safety Agency Approvals	6-3
6.5 Electromagnetic Compatibility (EMC)	6-3
Warranty	

LIST OF FIGURES

<u>FIGURE AND TITLE</u>	<u>PAGE</u>
1-1 Remote I/O Rack	1-1
2-1 Example of Remote I/O Rack Identification Label.....	2-1
2-2 Remote I/O Rack Dimensions	2-4
2-3 Mounting a Remote I/O Rack.....	2-7
2-4 Remote I/O Rack IOBUS Connections	2-8
2-5 Cable Tie Points for Strain Relief	2-9
2-6 IOBUS Connections - SIXRAC to Remote I/O Rack.....	2-11
2-7 IOBUS Connections - Remote I/O Rack to Remote I/O Rack	2-12
2-8 IOBUS Connections - MODULRACK to Remote I/O Rack	2-13
2-9 Remote I/O Rack Backplane Details.....	2-14
2-10 IOBUS Extension Cable.....	2-14
2-11 W2072 Cable End Preparation.....	2-17
2-12 Terminal Block to Rack W2072 Cabling up to 300 ft. (91 m) for Redundant or Non-Redundant Systems	2-18
2-13 Rack to Rack W2072 Cabling up to 300 ft. (91 m) for Redundant or Non-Redundant Systems	2-19
2-14 W2040 Cable End Preparation.....	2-22
2-15 Terminal Block to Rack W2040 Cabling up to 1500 ft. (460 m) for Non-Redundant APACS+ Systems.....	2-23
2-16 Rack to Rack W2040 Cabling up to 1500 ft. (460 m) for Non-Redundant APACS+ Systems.....	2-24
2-17 Belden 8627 Cable End Preparation	2-27
2-18 Terminal Block to Rack W2040/8627 Cabling up to 1500 ft. (460 m) for Node-to-Node Redundant APACS+ and All QUADLOG Systems.....	2-28
2-19 Rack to Rack W2040/8627 IOBUS Cabling up to 1500 ft. (460 m) for Node to Node Redundant APACS+ and All QUADLOG Systems.....	2-29
2-20 Modifying an IOBUS Cable	2-30
2-21 Shunt and Attenuator Orientations.....	2-32
2-22 Example IOBUS with Attenuator Installed.....	2-33
2-23 Example OK Loop Jumper.....	2-32
2-24 OK Loop Jumpers on Backplane.....	2-34
2-25 Rack Address and Slot Address Switches.....	2-35
2-26 Bottom View of rack Showing Built-in Recirculating Fans	2-37
2-27 Pinout of Power Bus Connector	2-38
2-28 Power Supply Cable	2-38
2-29 Protective Conductor Terminal	2-39
2-30 Installing Module End of I/O Interconnect Cable	2-40
2-31 Rack and I/O Module Keying.....	2-42

LIST OF TABLES

<u>TABLE AND TITLE</u>	<u>PAGE</u>
1-1 TIC Contact Information	1-4
2-1 IOBUS Cable Color Code and Connection Points.....	2-16
5-1 Remote I/O Rack Accessories	5-1
5-2 Remote I/O Rack Attachments	5-1
5-3 Remote I/O Rack Options	5-2
6-1 Remote I/O Rack Mechanical Specifications	6-1
6-2 Remote I/O Rack Environmental Specifications	6-1
6-3 Remote I/O Rack Electrical Specifications	6-2
6-4 Agency Approvals	6-3

Siemens Moore Process Automation, Inc. assumes no liability for errors or omissions in this document or for the application and use of information included in this document. The information herein is subject to change without notice.

*APACS+ and QUADLOG are trademarks of Siemens Moore Process Automation, Inc.
All other trademarks are the property of the respective owners.*

© Copyright 2001 Siemens Moore Process Automation, Inc. All rights reserved.

1.0 Introduction

This Instruction provides installation and service information for the Remote I/O Rack (P/N 16426-1), a four slot rack that houses one to four plug-in APACS+™ or QUADLOG® I/O modules. This Instruction is divided into six major sections.

- Section 1, Introduction - Provides a product description, support information, and lists related literature.
- Section 2, Installation - Describes environmental considerations and mechanical and electrical installation procedures.
- Section 3, Maintenance - Provides periodic maintenance procedures, repair recommendations, and suggestions for spare and replacement parts.
- Section 4, Circuit Description - Briefly describes the backplane circuitry and signals.
- Section 5, Accessories, Attachments, and Options - Lists the available accessories, attachments, and options available for the Remote I/O Rack.
- Section 6, Specifications – Lists the rack's mechanical, electrical, and environmental specifications.

1.1 Product Description

The Remote I/O Rack, shown in Figure 1-1, is a four-slot rack intended to house up to four plug-in APACS+ or QUADLOG I/O modules. All I/O modules are hot-swap capable. This means a module can be replaced while the power to the Remote I/O Rack is on.



Figure 1-1 Remote I/O Rack

The rack is flanged for flush mounting on a flat surface such as a wall or instrument panel. The rack can also be mounted on a flat panel inside a Siemens Moore MODULPAC enclosure, or on a flat panel within a third-party enclosure.

Each module in the Remote I/O Rack connects to its I/O field wiring via an Interconnect I/O Cable Assembly. Each cable extends from a module's slot position in the rack to a companion marshalled termination assembly that provides I/O field terminals. Installation of these cable assemblies is commonly performed at the time of rack installation.

The Remote I/O Rack can function as a four-module I/O subsystem or it can be used to extend the I/O module capacity of a SIXRAC from six to ten modules.

Since the Remote I/O Rack is intended for I/O modules, it must be connected to a control resource such as a control module [e.g., Advanced Control Module (ACM)] to form a controller. This connection is made over the IOBUS (detailed below). In this document, the term "controller" refers to a control resource plus its associated I/O modules.

When an I/O module is inserted into a slot of the Remote I/O Rack, it becomes a node on the following buses:

- **IOBUS** – A redundant (A and B) serial bus with a 1 Mbps data transmission rate that provides a control module with dedicated, secure access to field I/O points via I/O modules. Generally, an IOBUS can span a maximum of 40 slots consisting of any combination of Remote I/O Racks (4 slots), SIXRACs (6 slots), MODULRACs (10 slots), and UNIRACs (1 slot). These racks are interconnected serially with IOBUS A and B cables. Note that each control module (ACM, CCM), Bus Continuation Module (BCM), Bus Diverter Module (BDM), and each empty slot counts as a slot.

Two removable dual-function (Bus Terminate or Bus Continue) IOBUS Shunts are provided for easy set-up for either end-of-bus termination or bus-continuation to other racks in the chain. The Remote I/O Rack provides one continuous IOBUS segment (four nodes).

An attenuator is supplied with each Remote I/O Rack. When an IOBUS extends 30 meters or longer, attenuation is required to protect against signal reflections in the event one side of the IOBUS (A or B) is inadvertently disconnected or severed.

- **Power Bus** – A triple bus that supplies 24 Vdc operating power to I/O modules from up to three independent power sources. Each power source is applied to the Power Bus via a plug-in cable from an externally mounted power supply, such as POWERAC.

The Remote I/O Rack's backplane contains DC power bus connectors. It also contains the IOBUS connectors to expand the IOBUS to additional racks if required.

A thumbwheel switch on the backplane is used to assign a Remote I/O Rack address (1 to 16) for software identification of I/O modules in communications throughout the system.

A slot address range slide switch on the backplane is used to set whether the Remote I/O Rack is to occupy lower slot addresses (1 to 4) for standalone use, or upper slot addresses (7 to 10) when used as an extension to another rack such as a SIXRAC.

1.2 Product Support

Product support can be obtained from a Technical Information Center (TIC). Each regional TIC is a customer service center that provides direct telephone support on technical issues related to the functionality, application, and integration of all products supplied by Siemens Moore. Regional TIC contact information is provided in Table 1-1. Your regional TIC is the first place you should call when seeking product support information. When calling, it is helpful to have the following information ready:

- Caller ID number, or name and company name - When someone calls for support for the first time, a personal caller number is assigned. Having the number available when calling for support will allow the TIC representative taking the call to use the central customer database to quickly identify the caller's location and past support needs.
- Product part number or model number and version
 - If there is a problem with product operation:
 - Whether or not the problem is intermittent
 - The steps performed before the problem occurred
 - Any error messages or LED indications displayed
 - Installation environment

Customers that have a service agreement (ServiceSuite or Field Service Agreement) are granted access to the secure area of our website (www.smpa.siemens.com/techservices). This area contains additional product support information. To log on, you will be prompted to enter your *username* and *password*.

Table 1-1 TIC Contact Information

TIC NORTH AMERICA	Tel:	+1 215 646 7400, extension 4842
	Fax:	+1 215 283 6343
	E-mail:	TICGroupNA@smpa.siemens.com
	Hours of Operation:	8 a.m. to 6 p.m. eastern time Monday – Friday (except holidays)
	Secure Web Site:	www.smpa.siemens.com/techservices



TIC ASIA	Tel:	+65 299 6051
	Fax:	+65 299 6053
	E-mail:	TICGroupAP@smpa.siemens.com
	Hours of Operation:	9 a.m. to 6 p.m. Singapore time Monday – Friday (except holidays)
	Secure Web Site:	www.smpa.siemens.com/techservices

TIC EUROPE	Tel:	+44 1935 470172
	Fax:	+44 1935 706969
	E-mail:	TICGroupEurope@smpa.siemens.com
	Hours of Operation:	8:30 a.m. to 5:15 p.m. GMT/BST Monday – Thursday (except holidays) 8:30 a.m. to 4:00 p.m. GMT/BST Friday (except holidays)
	Secure Web Site:	www.smpa.siemens.com/techservices

1.3 International Standards Organization (ISO) Symbols

Refer to Table 1-2 for an explanation of ISO (International Standards Organization) and IEC (International Electrotechnical Commission) symbols that, when appropriate, are prominently displayed on the surfaces of hardware. The symbols are also used in instructions to denote **CAUTION** and **WARNING** notes.

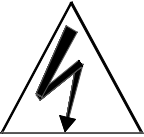
Table 1-2 ISO/IEC Symbols

Symbol	Publication	Description
 <p>Background Color = Yellow Symbol Color = Black Outline Color = Black</p>	ISO 3864, No. B.3.6	<p>WARNING: Risk of Electric Shock. The symbol is prominently displayed on the surfaces of hardware. When used in an instruction, text accompanies the symbol to identify something that can be dangerous and possibly life threatening to personnel. For example:</p> <p>WARNING: Risk of electric shock. Remove power from all involved wires before making connections to the Marshall Termination Assembly.</p>
 <p>Background Color = Yellow Symbol Color = Black Outline Color = Black</p>	ISO 3864, No. B.3.1	<p>CAUTION: Refer to accompanying Installation and Service Instruction. The symbol is prominently displayed on the surfaces of hardware. When used in an instruction, text accompanies the symbol to identify something that can damage equipment or cause a control problem with a process. For example:</p> <p>CAUTION: The safety system should not be operated with forced I/O.</p>
 <p>Background Color = White Symbol Color = Black Outline Color = Black</p>	IEC 417, No. 5019	<p>PROTECTIVE CONDUCTOR TERMINAL Symbol is prominently displayed on the surfaces of hardware.</p>

1.4 Related Literature

The following documents are available to complement the installation, configuration, and maintenance of the Remote I/O Rack. Generally, all needed documentation is supplied with your equipment. It may be supplied in electronic form in the Adobe™ portable document format (PDF), printed form, or both. Refer to these documents as needed or as called for in text. Documents may be located on your workstation's hard drive or on a CD supplied with your system.

- *Grounding Practices Installation and Service Instruction* (document number SD39GND-1)
- *MODULPAC 2000 Installation and Service Instruction* (document number SD39MODULPAC-2)
- *Power Supply Rack (POWERAC) Installation and Service Instruction* (document number SD39PSR-1)
- *SIXRAC Installation and Service Instruction* (document number SD39SIXRAC-1)

#

2.0 Installation

This section describes installation of the Remote I/O Rack. Review and complete the preparatory steps in section 2.2 before proceeding with the installation.

IMPORTANT

The Remote I/O Rack installation should be in accordance with the National Electrical Code (NEC) and other applicable construction and electrical codes.

2.1 Hardware Identification

The Remote I/O Rack is identified by a label affixed to the left side of its chassis. An example label is shown in Figure 2-1. It provides Remote I/O Rack information such as its model, part number, and serial number (S/N). It also lists power requirements, and space is provided for additional information, such as safety agency certifications. Refer to the label on an actual Remote I/O Rack for its specific information.

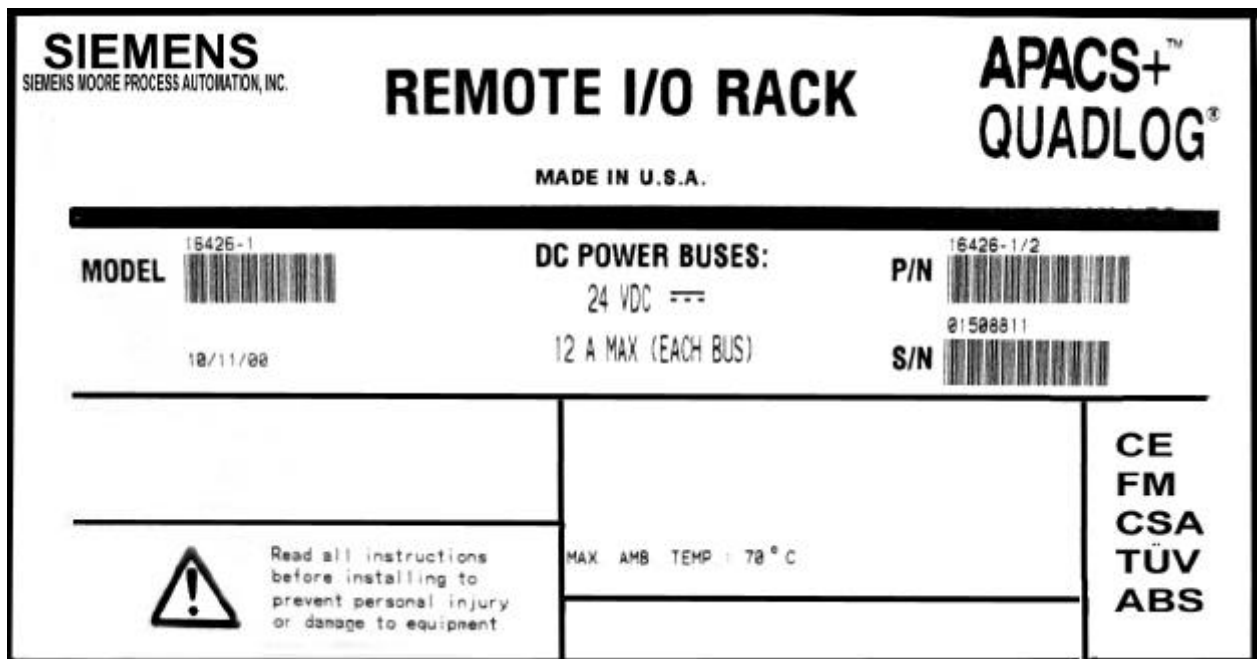

Figure 2-1 Example of Remote I/O Rack Identification Label

2.2 Installation Considerations and Preparations

Review sections 2.2.1 and 2.2.2 before beginning a Remote I/O Rack installation.

2.2.1 EMC Directive Installation Considerations

Some Remote I/O Rack installations require adherence to the European Union's Electromagnetic Compatibility (EMC) Directive. Refer to the "Declaration of Conformity" statement at the back of this document that lists the certificate number of the Technical Construction File issued to this product. Contact Siemens Moore for additional information concerning EMC Directive installation.

2.2.2 Preparation

This section presents an overview of the steps to be performed before beginning a Remote I/O Rack installation. The selection of I/O modules, enclosures, and other APACS+ and/or QUADLOG assemblies is described in detail in other documents, and assistance is also available from your local Siemens Moore Technical Information Center (TIC).

1. Determine the following:
 - 1) The number and types of I/O modules needed and the need for redundancy
 - 2) The overall scope of controller communications and the number of racks needed to accommodate needed control and I/O modules. There are four types of racks available: UNIRAC (up to three slots), Remote I/O Rack (four slots), SIXRAC (six slots), and MODULRAC (ten slots). Note the following:
 - An IOBUS can support a maximum of 40 slots as described in section 1.1. The actual capacity depends upon the type of rack used or the combination of racks and modules used. For example, the Remote I/O Rack can function as a four-module I/O subsystem or it can be used to extend the I/O module capacity of a SIXRAC from six to ten modules. Since the Remote I/O Rack supports only I/O modules, the associated control module must be located in another rack such as a SIXRAC.
 - While not directly affecting a Remote I/O Rack but important for system planning, a maximum of 32 control modules can reside on a MODULBUS (M-BUS). Only MODULRACs and SIXRACs support the MODULBUS. A MODULBUS can extend across a maximum of four SIXRACs, or four MODULRACs, or a combination of both that equals four racks.
 - 3) Determine the sum of the IOBUS cable lengths needed to interconnect one or more racks (Remote I/O Racks, SIXRACs, MODULRACs, and UNIRACs). Refer to section 5 in this document for maximum cable lengths.

- In a non-redundant or module-to-module redundant APACS+ system, when IOBUS cable length needs are longer than the maximum standard cable 98.4 ft (30 m), an unterminated two-conductor shielded cable can be spliced into a standard IOBUS cable
 - In a rack-to-rack redundant or any QUADLOG system, when IOBUS cable length needs are longer than the maximum standard cable 98.4 ft. (30 m), an unterminated six-conductor shielded cable can be spliced into a standard IOBUS cable
2. Determine the number of racks to be installed. The Remote I/O Rack is intended for flush mounting on a flat surface such as an instrument panel or wall.
 3. If required, up to four Remote I/O Racks (marshalled I/O terminations only) can be installed in a MODLUPAC enclosure if one or more flat panels are installed in the enclosure first. If an enclosure is user-supplied, refer to Figure 2-2 for Remote I/O Rack dimensions and determine the desired enclosure layout.
 4. Prepare or amend system drawings to document:
 - The physical location of Remote I/O Rack(s), plug-in I/O modules, and other related items such as power supplies and marshalled termination assemblies
 - Identify the routing of all associated cables and power wiring (e.g. DC power, twinaxial communications cable, IOBUS, and MODULBUS). Do not assign IOBUS cables to conduits containing telephone lines
 - The position of each backplane IOBUS Shunt (refer to section 2.5.6 for IOBUS Shunt information)
 - Each Remote I/O Rack's intended rack address and slot switch setting
 5. Install needed cable raceways and conduits.
 6. Install Remote I/O Racks and associated marshalled termination assemblies at their intended installation sites. Where applicable, identify cable entrances in cabinets. Tag and route IOBUS extension cables; pull them into the cabinets.
 7. For each Remote I/O Rack, set its rack address switch and slot address range switch according to system drawings.
 8. Key and install I/O modules in the Remote I/O Rack(s). For detailed installation instructions, refer to the information in this document and the documentation for each I/O module.

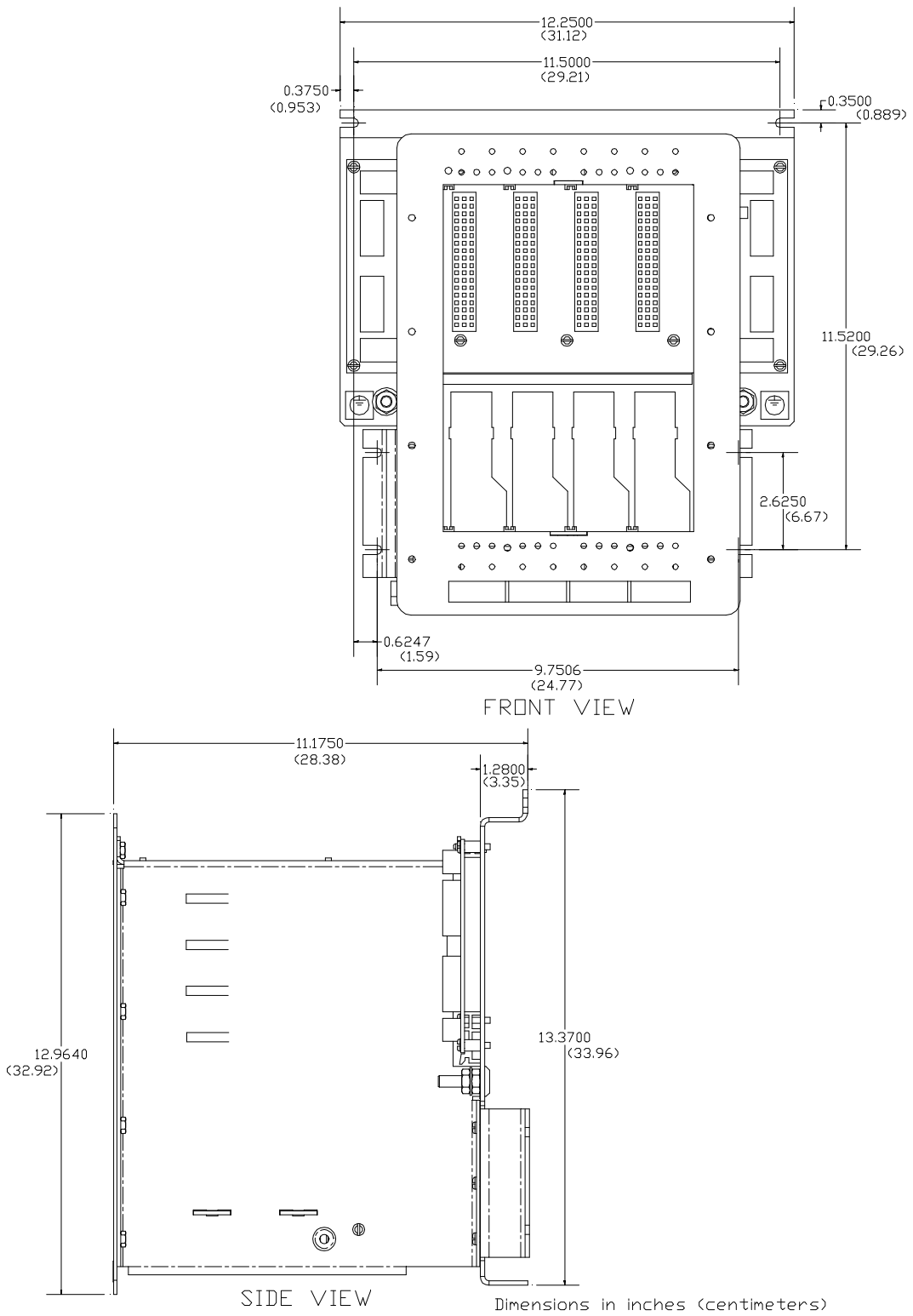

Figure 2-2 Remote I/O Rack Dimensions

2.2.3 Environmental Considerations

Refer to section 6.2 for environmental specifications. In cases where a Remote I/O Rack is installed in an enclosure such as a MODULPAC, the internal air temperature may be measured to be sure the specified operating temperature of any installed assembly is not being exceeded. Each APACS+ or QUADLOG I/O module contains an internal temperature sensor that activates an alarm if the module's internal temperature exceeds maximum specified limits. The air surrounding an I/O module must be within the specification stated in the module's documentation. The Remote I/O Rack has two built-in circulating fans to remove heat from installed I/O modules.



Exceeding the specified operating temperature limits can adversely affect performance and may cause damage.

Industrial environments often contain particulate, liquid, and gaseous contaminants. Particulate matter, usually dust and dirt, is abrasive and can cause intermittent contact in connectors associated with the Remote I/O Rack's backplane. Liquid and gaseous contaminants can have a corrosive effect on metal, rubber, plastic and circuit board components. Extended exposure to these contaminants may result in equipment malfunction.

To reduce contaminant related equipment malfunctions:

- Identify contaminants and implement methods to reduce their presence.
- When cleaning equipment and surrounding area, especially the floor, either vacuum away all dust and dirt or use a dampened rag or mop. Clean or replace all air conditioning and room air filters, and equipment filters regularly. Inform all personnel with access to the equipment of the need for site cleanliness.

2.2.4 Equipment Delivery and Handling

The following subsections provide information of interest to shipping, receiving, and warehouse personnel.

2.2.4.1 Predelivery Inspection

The Remote I/O Rack is fully inspected prior to shipment. If a Remote I/O Rack is ordered factory-installed on an instrument panel or within an enclosure, it is tested together (staged) as part of the overall system to ensure proper operation.

2.2.4.2 Factory Shipment

Each Remote I/O Rack to be installed by the user is placed in protective material and packaged for shipment. Accessories are packaged separately. If a Remote I/O Rack is ordered factory installed on an instrument panel or mounted on a panel within an enclosure, the complete assembly is bolted to a pallet and wrapped for protection for shipment.

2.2.4.3 Receipt of Shipment

All cartons should be inspected at the time of their delivery for possible external damage. Any visible damage should be immediately recorded on the carrier's copy of the delivery slip.

Each carton should be carefully unpacked and its contents checked against the enclosed packing list. At the same time, each item should be inspected for hidden damage that may or may not have been accompanied by exterior carton damage.

If it is found that some items have been damaged or are missing, notify Siemens Moore immediately and provide full details (see section 3.5 or 3.6). In addition, damages must be reported to the carrier with a request for their on-site inspection of the damaged item and its shipping carton.

2.2.4.4 Equipment Handling and Storage

A Remote I/O Rack can be safely handled without undertaking special handling procedures; however, do not subject it to excessive shock or vibration. The storage temperature and humidity parameters of section 6.2 must be met for rack storage.

2.3 Remote I/O Rack Mounting

The Remote I/O Rack is flanged for flush mounting on a flat surface such as a wall or instrument panel. The rack can also be mounted on a flat panel inside a Siemens Moore MODULPAC enclosure, or on a flat panel within a third-party enclosure. An example installation is shown in Figure 2-3.

To mechanically mount a Remote I/O Rack:

1. If applicable, install or locate the panel to which the Remote I/O Rack is to be mounted.
2. Locate the six screw slots on the Remote I/O Rack's mounting flanges.
3. Temporarily position the Remote I/O Rack at its intended mounting position on the flat mounting surface (wall or instrument panel). After making sure the top of the rack is level, use a pencil to mark the mounting surface at each screw slot location in the flange to prepare for drilling mounting holes. For rack dimensions and mounting information, see Figure 2-2 and 2-3 respectively. After marking hole positions, set the rack aside.
4. Drill holes in the flat mounting surface at each marked location. Where applicable, tap each drilled hole

or install screw anchors. You are to supply the appropriate fastening hardware.

5. Position the Remote I/O Rack at its mounting position on the flat surface (wall or instrument panel) and secure it in place with the appropriate fasteners.

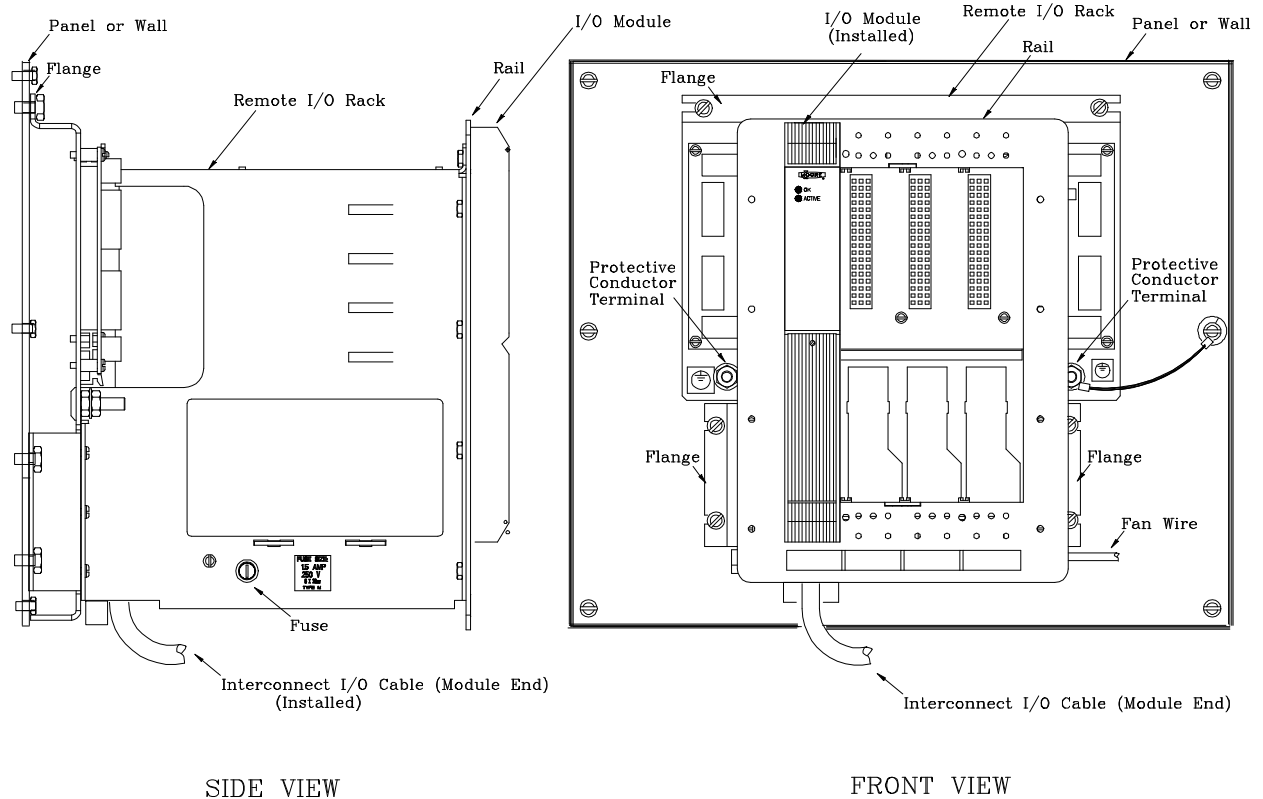
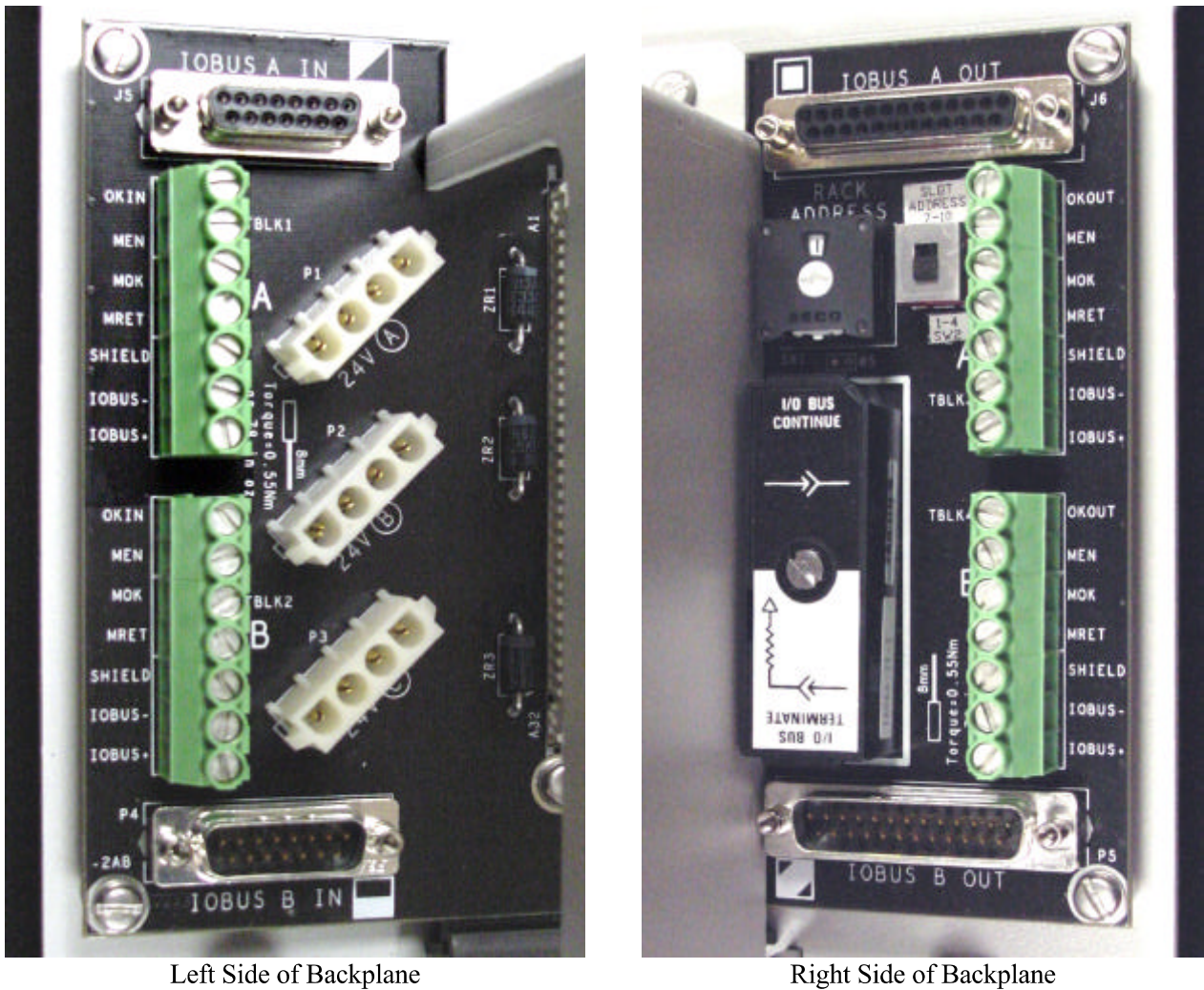

Figure 2-3 Mounting a Remote I/O Rack

2.4 APACS+ Cable Latching and Strain Relief Mechanisms

APACS+ employs two cable latching mechanisms; the spring latch type and the screwlock type. The plug-in type IOBUS connectors on the backplane of the Remote I/O Rack, and all associated cables listed in Table 5-3, feature the screwlock type mechanism. Earlier APACS+ system devices used spring latch cable parts and cable connection points. To accommodate system upgrade or retro-fit situations where a cable must mate with an incompatible connector, a Cable Adapter Kit (P/N 16056-593) is available for conversion from the spring latch type to screwlock type or vice versa.

The Remote I/O Rack features IOBUS connectors at each IOBUS connection point. As shown in Figure 2-4, IOBUS A/B IN connection points are on the left side of the rack's backplane and IOBUS A/B OUT connection points are on the right side. Each IOBUS connection point has both a screw lock connector and screw terminals connected in parallel to accommodate various IOBUS connection schemes.



Left Side of Backplane

Right Side of Backplane

Figure 2-4 Remote I/O Rack IOBUS Connectors

The Remote I/O Rack provides three strain relief tie points on each side of its chassis. For reference, tie points on the left side of the chassis are shown in Figure 2-5. The tie points are intended to provide strain relief to IOBUS, power supply, and cooling fan cables. Secure cables to the tie points with common cable ties.



Figure 2-5 Cable Tie Points for Strain Relief

IMPORTANT

APACS+ and QUADLOG hardware is certified to meet certain safety agency (EMC, CSA) vibration, and temperature standards. To ensure that test certifications are not violated, note the following:

- ESD covers and dust covers on unused connectors must be attached at all times.
- Cables must be secured at all times by screwlock mechanisms.
- No unauthorized modifications are allowed to APACS+ or QUADLOG products.

2.5 IOBUS Cable and Shunt/Jumper Connections

The IOBUS is redundant (sides A and B) and can have a maximum capacity of 40 nodes defined as one control module and up to 39 I/O modules. The actual nodal capacity depends upon the type of rack used or the combination of racks used (see section 2.2.2).

A minimum node IOBUS consists of two modules: a control module and an I/O module; however, the control module must reside in a SIXRAC or a MODULRAC to communicate over the MODULBUS (M-BUS). The IOBUS capacity of a Remote I/O Rack is fixed at four modules (nodes) and cannot be configured into separate segments; however, the Remote I/O Rack's IOBUS can continue into other Remote I/O Racks, SIXRACs, MODULRACs, or UNIRACs. IOBUS cables and shunts (see Figures 2-6 through 2-10) are used to establish the physical length of an IOBUS.

2.5.1 Standard IOBUS Cable Connections

Standard IOBUS cables, shown in Figure 2-10, are available in several lengths as defined in section 5.3. Refer to section 6 for the maximum cable length when interconnecting several racks. Each IOBUS cable end and each IOBUS connector on the Remote I/O Rack are marked with a graphic symbol for identification. When connecting an IOBUS cable end to a rack, these graphic symbols must match at the connection point. There are many IOBUS connections possible among the different racks available. Example IOBUS connections for common Remote I/O Rack arrangements are shown in Figures 2-6, 2-7, and 2-8.

To make IOBUS connections:

1. Use the shortest length cable when racks are mounted in close proximity to one another or within the same enclosure. When racks are mounted farther apart or in separate enclosures, longer cables are needed. IOBUS cables to be connected to a Remote I/O Rack connect to the IOBUS connectors located on the left or right side of the rack's backplane as shown in Figure 2-4 and 2-9.
2. Connect the involved racks as described below:
 - A) Consult system drawings to identify the type of racks associated with IOBUS, including those mounted in separate cabinets.
 - B) If racks are located in separate cabinets, IOBUS cables should already have been routed between cabinets and tagged. Refer to the following examples:
 - Example A: Connecting a SIXRAC (or MODULRAC) to a Remote I/O Rack:
Connect SIXRAC 1, IOBUS A OUT, J19 to Remote I/O Rack 1, IOBUS A IN, J5
Connect SIXRAC 1, IOBUS B OUT, P24 to Remote I/O Rack 1, IOBUS B IN, P4
 - Example B: Connecting one Remote I/O Rack to another Remote I/O Rack:
Connect Remote I/O Rack1, IOBUS A OUT, J6 to Remote I/O Rack 2, IOBUS A IN, J5
Connect Remote I/O Rack 1, IOBUS B OUT, P5 to Remote I/O Rack 2, IOBUS B IN, P4
 - C) If more than one rack is mounted in an enclosure; install short IOBUS cables between racks. Tag each cable end with the rack number and connector destination.
 - D) If the IOBUS is to be terminated on a Remote I/O Rack or continues on to another rack, refer to section 2.5.6 for details on orienting the rack's IOBUS shunt.

NOTE

After completing IOBUS cable connections, **do not** form a loop by connecting the last rack to the first rack.

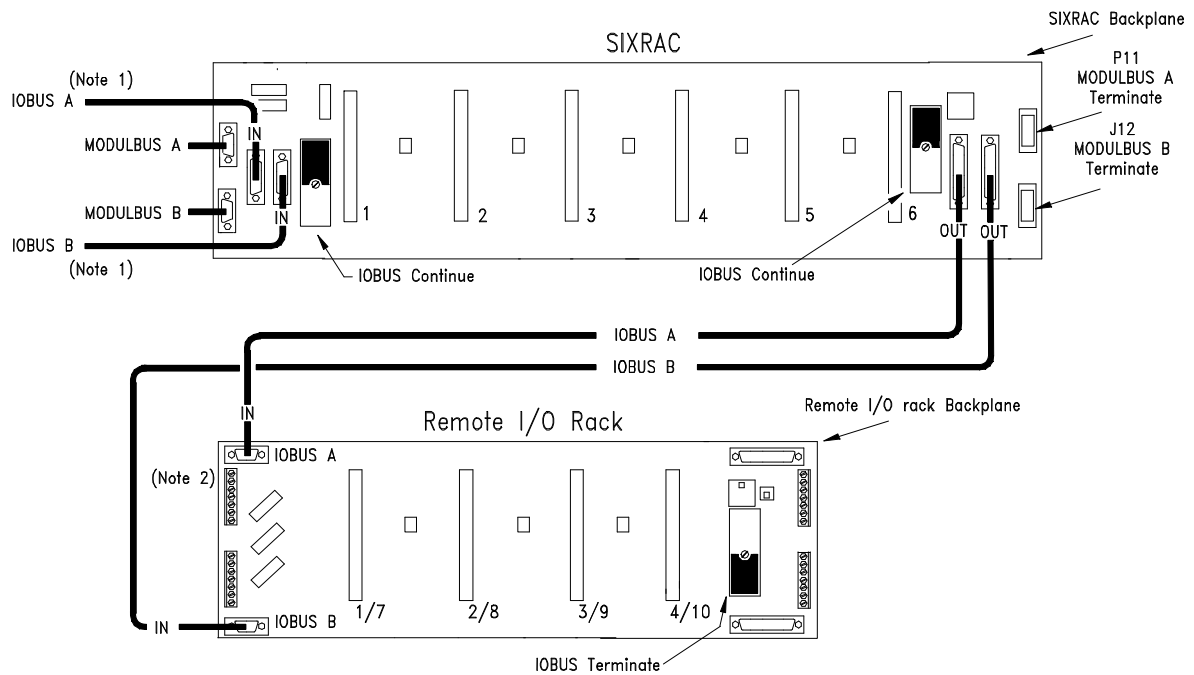

NOTES:

1. IOBUS A and B must be terminated at beginning and end. (Only termination on end shown here.) Remote I/O rack must be on end
2. On Remote I/O Rack, IOBUS connector and adjacent screw terminals are electrically parallel.

Figure 2-6 IOBUS Connections – SIXRAC to Remote I/O Rack

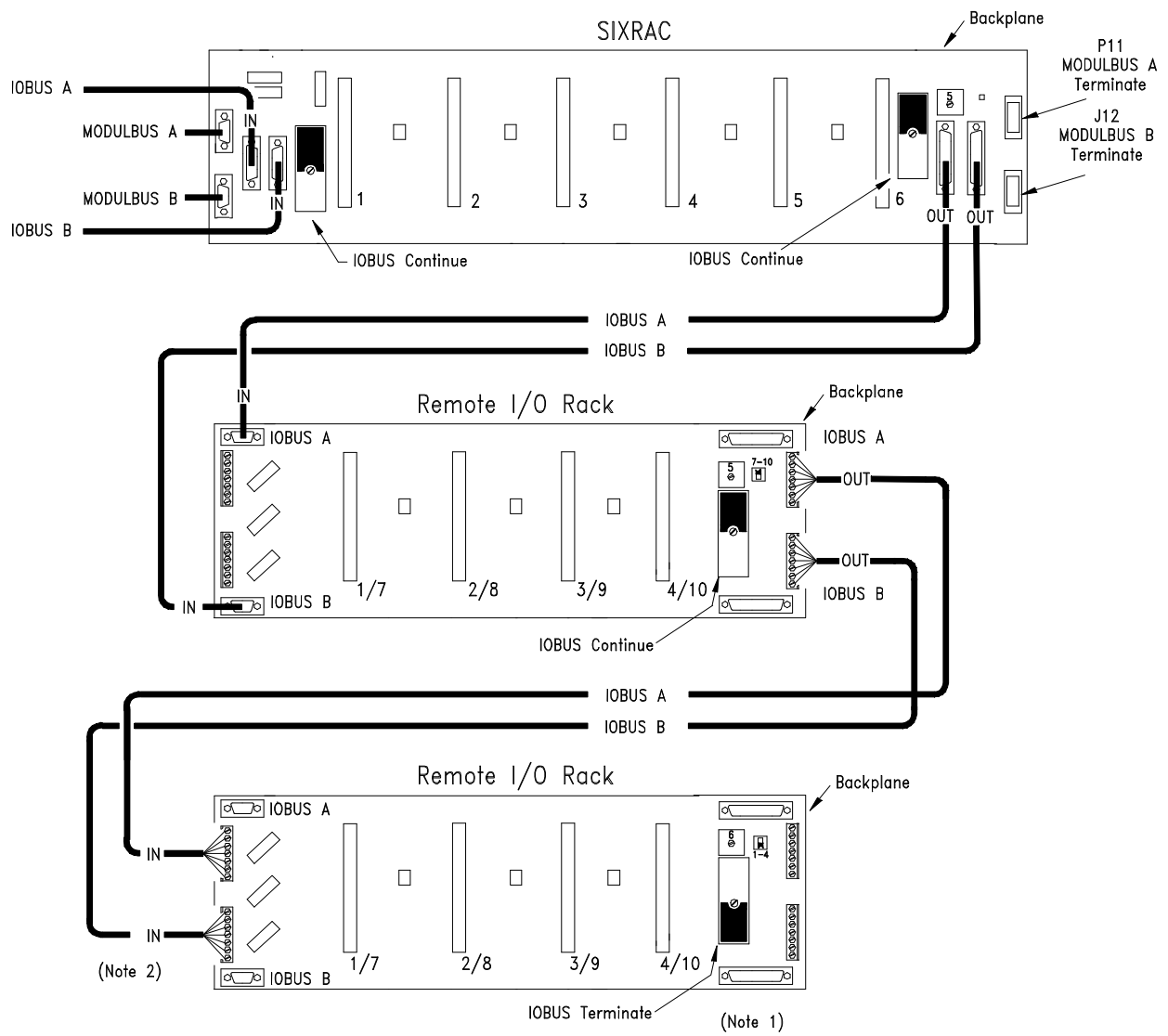

NOTES:

1. IOBUS A and B must be terminated at beginning and end. (Only termination on end shown here.) Remote I/O rack must be on end
2. On Remote I/O Rack, IOBUS connector and adjacent screw terminals are electrically parallel.

Figure 2-7 IOBUS Connections – Remote I/O Rack to Remote I/O Rack

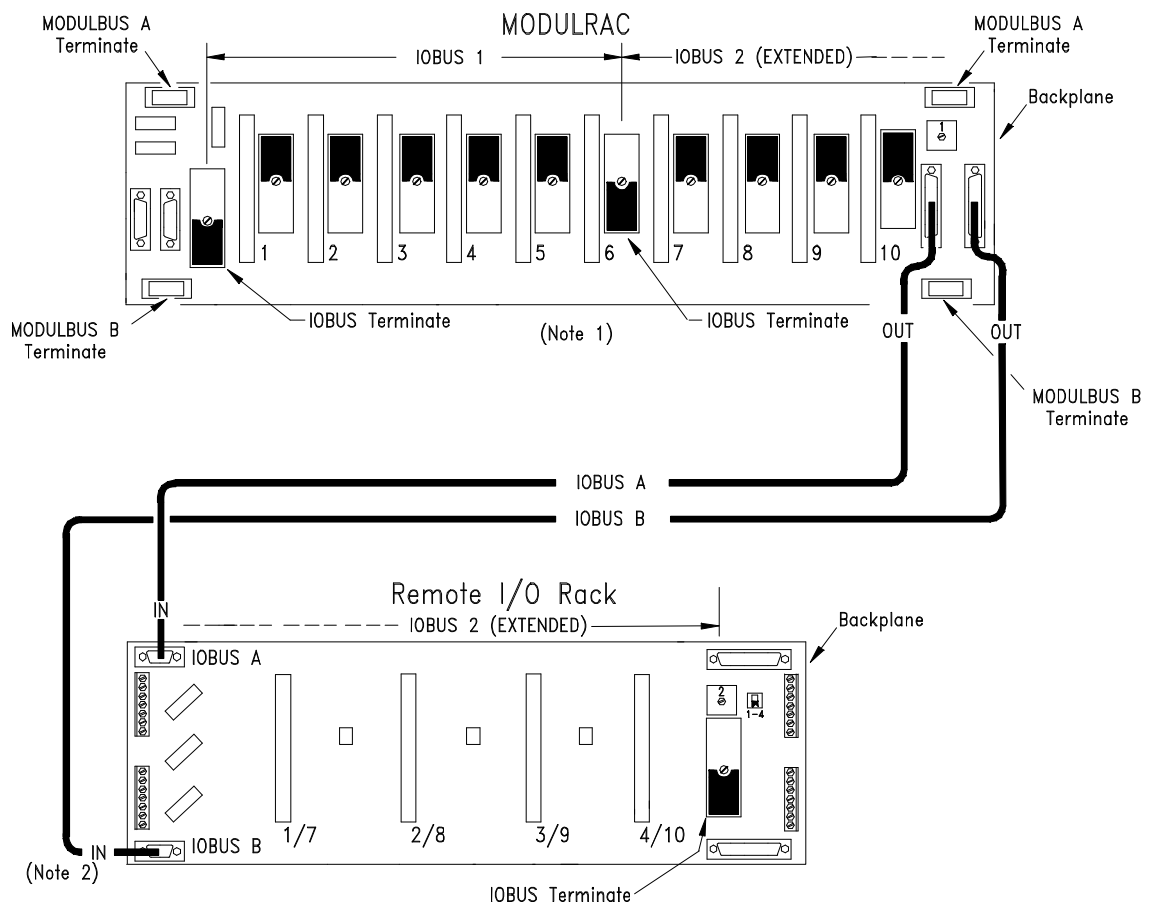

NOTES:

1. IOBUS A and B must be terminated at beginning and end. Remote I/O rack must be on end.
2. On Remote I/O Rack, IOBUS connector and adjacent screw terminals are electrically parallel.

Figure 2-8 IOBUS Connections – MODULRAC to Remote I/O Rack

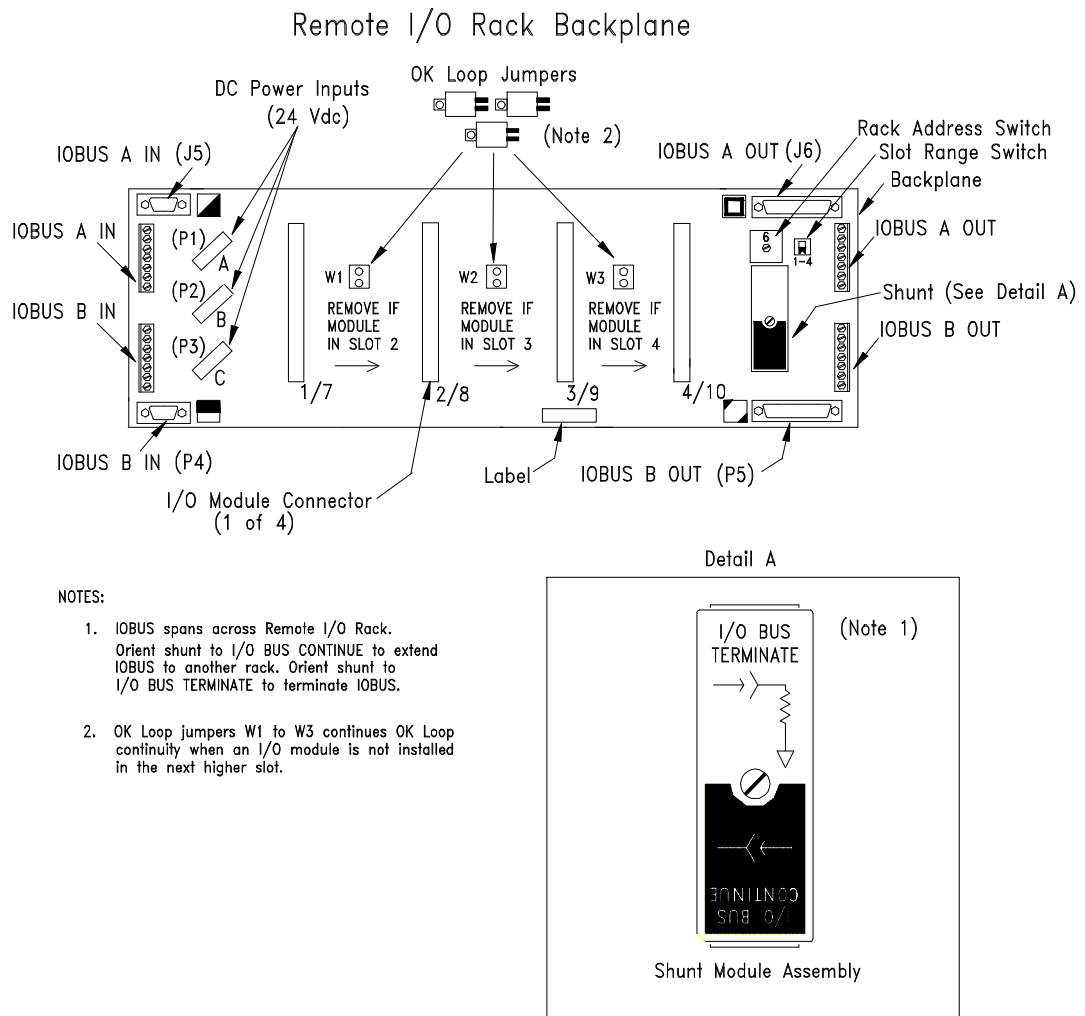

Figure 2-9 Remote I/O Rack Backplane Details

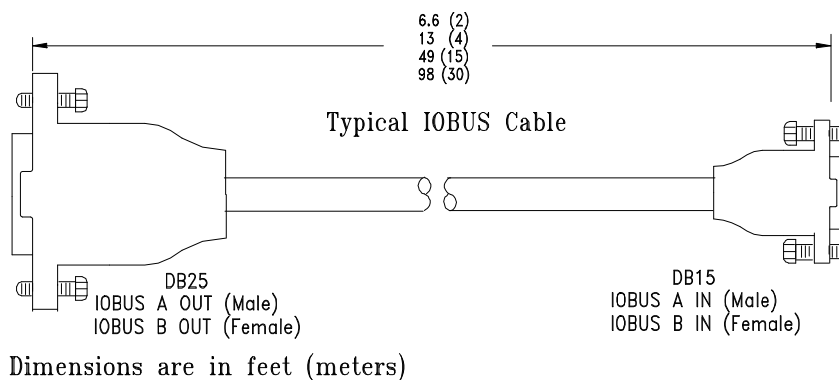

Figure 2-10 IOBUS Extension Cable

2.5.2 IOBUS Cable Connection up to 300 ft. (91 m) for Redundant and Non-Redundant Systems

This section describes the preparation and installation of IOBUS cables for rack-to-rack redundant or non-redundant APACS+ or QUADLOG systems when the needed cable length exceeds the maximum standard length of 98.4 Feet (30 meters) of a factory-prepared IOBUS cable, but is less than 300 feet (91 meters).

The cable preparation procedure provided here involves splicing a custom-length cable that has unprepared ends. This kind of cable is type W2072. It is intended for use as an IOBUS extension cable between two Remote I/O Racks, or between a Remote I/O Rack and another type of rack (e.g., MODULRAC or SIXRAC).

The Remote I/O Rack can accommodate either prepared or unprepared ends of available IOBUS cable(s). A prepared cable end has a molded connector on it and is to be plugged into the appropriate IOBUS IN or IOBUS OUT connector on the rack's backplane (see Figure 2-4). The wires emerging from an unprepared cable end are to be individually stripped and connected directly to the screw terminals of the associated IOBUS IN or IOBUS OUT terminal block, also located on the rack's backplane (see Figure 2-4).

When another type of rack (e.g., MODULRAC or SIXRAC) is also used, it requires a prepared cable end (with a connector) to attach that rack to the IOBUS. In these instances, you must supply DIN rail-mounted style terminal blocks (one for A side and one for B side). The terminal blocks are needed to transition between a W2072 unprepared cable end and another cable segment that has a prepared end that is usually obtained by cutting a standard IOBUS extension cable in half and preparing the cut end. To modify an IOBUS cable in this way, refer to section 2.5.5. Each user supplied terminal block must be able to accommodate wire sizes of 16 to 28 AWG (1,3 mm² to 0.09 mm²).

IMPORTANT

It is important to preserve continuous cable impedance through all splice connections. This is to minimize signal reflections within the cable and help assure collision-free communications. After preparing cable ends, make sure each intended pair is re-twisted at the same intervals all the way to the screw terminals of the terminal blocks. Refer to Figures 2-12 and 2-13.

To connect a W2072 IOBUS cable between a terminal block and a Remote I/O Rack:

1. Determine the length of W2072 cable needed to connect from the terminal block location to the appropriate IOBUS connection point on the Remote I/O Rack's backplane. Allow slack for cable stripping, dressing, tagging, and strain relief at each end.
2. At the user-supplied terminal block, provide strain relief for the W2072 cable end. Connect the W2072 cable conductors (wires) to the terminal block. Wire stripping and color code information for making connections are provided in Table 2-1 and Figure 2-11 respectfully.

3. At the appropriate IOBUS screw terminals on the Remote I/O Rack's backplane (Figure 2-4), provide strain relief for the W2072 cable end by securing it to one of the rack's tie points (Figure 2-5). Connect the W2072 cable conductors (wires) to the screw terminals. Tighten screw terminals by applying 78 in oz (0.55 Nm) of torque. Wire stripping and color code information for making connections are provided in Table 2-1 and Figure 2-11 respectfully.
4. Tag each W2072 cable end as needed for identification.

To connect a W2072 IOBUS cable between two Remote I/O Racks:

1. Determine the length of W2072 cable needed to connect from the first Remote I/O Rack to the second Remote I/O Rack. Allow slack for cable stripping, dressing, tagging, and strain relief at each end.
2. At the appropriate IOBUS OUT screw terminals on the first Remote I/O Rack's backplane (Figure 2-4), provide strain relief for the W2072 cable end by securing it to one of the rack's tie points (Figure 2-5). Connect the W2072 cable conductors (wires) to the screw terminals as shown in Figure 2-13. Tighten screw terminals by applying 78 in oz (0.55 Nm) of torque. Wire stripping and color code information for making connections are provided in Table 2-1 and Figure 2-11 respectfully.
3. At the appropriate IOBUS IN screw terminals on the second Remote I/O Rack's backplane (Figure 2-4), provide strain relief for the W2072 cable end by securing it to one of the rack's tie points (Figure 2-5). Connect the W2072 cable conductors (wires) to the screw terminals as shown in Figure 2-13. Tighten screw terminals by applying 78 in oz (0.55 Nm) of torque. Wire stripping and color code information for making connections are provided in Table 2-1 and Figure 2-11 respectfully.
4. Tag each W2072 cable end as needed for identification.

Table 2-1 IOBUS Cable Color Code and Connection Pinouts

Terminal Block/Signal		Wire Color Code	DB15 Connector Pinout	DB25 Connector Pinout
IOBUS +	<i>Twisted Pair</i>	Orange\White Stripe	1	1
IOBUS -		White\Orange Stripe	2	2
MRET (Redundancy Signal)		White\Blue Stripe	3	3
MOK (Redundancy Signal)		White\Green Stripe	4	4
MEN (Redundancy Signal)		Blue\White Stripe	5	5
OKIN / OKOUT (Redundancy Signal)		Green\White Stripe	6 (OKIN)	6 (OKOUT)
SHIELD		Bare wire	-	-
-		-	-	7 to 25 unused

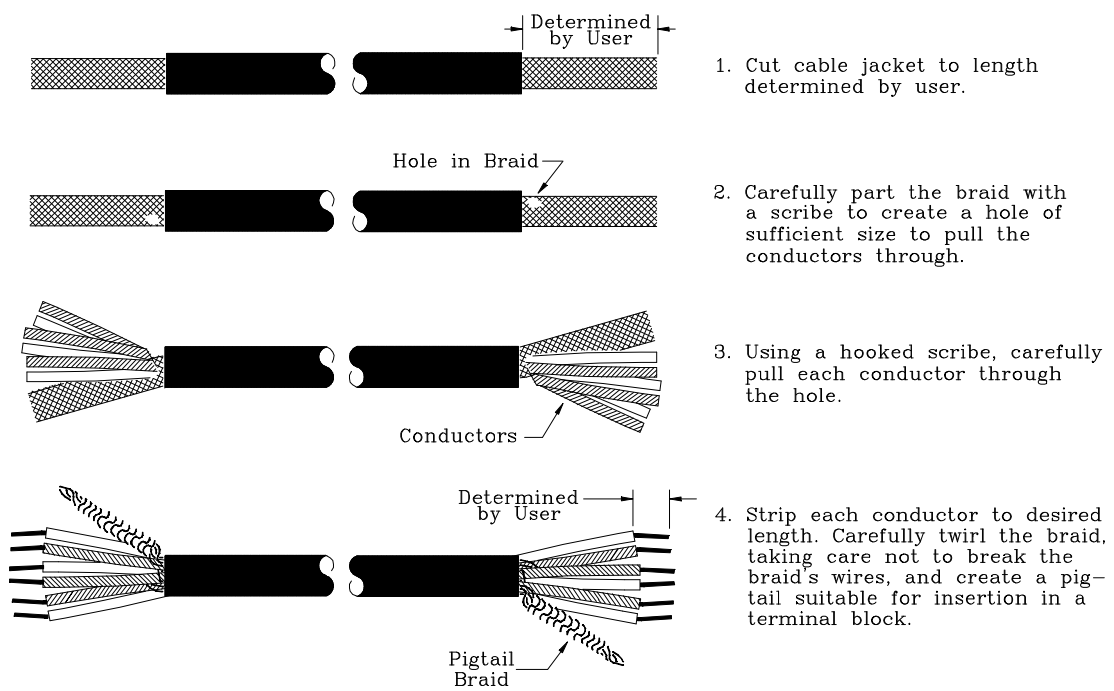

A0503501

Figure 2-11 W2072 Cable End Preparation

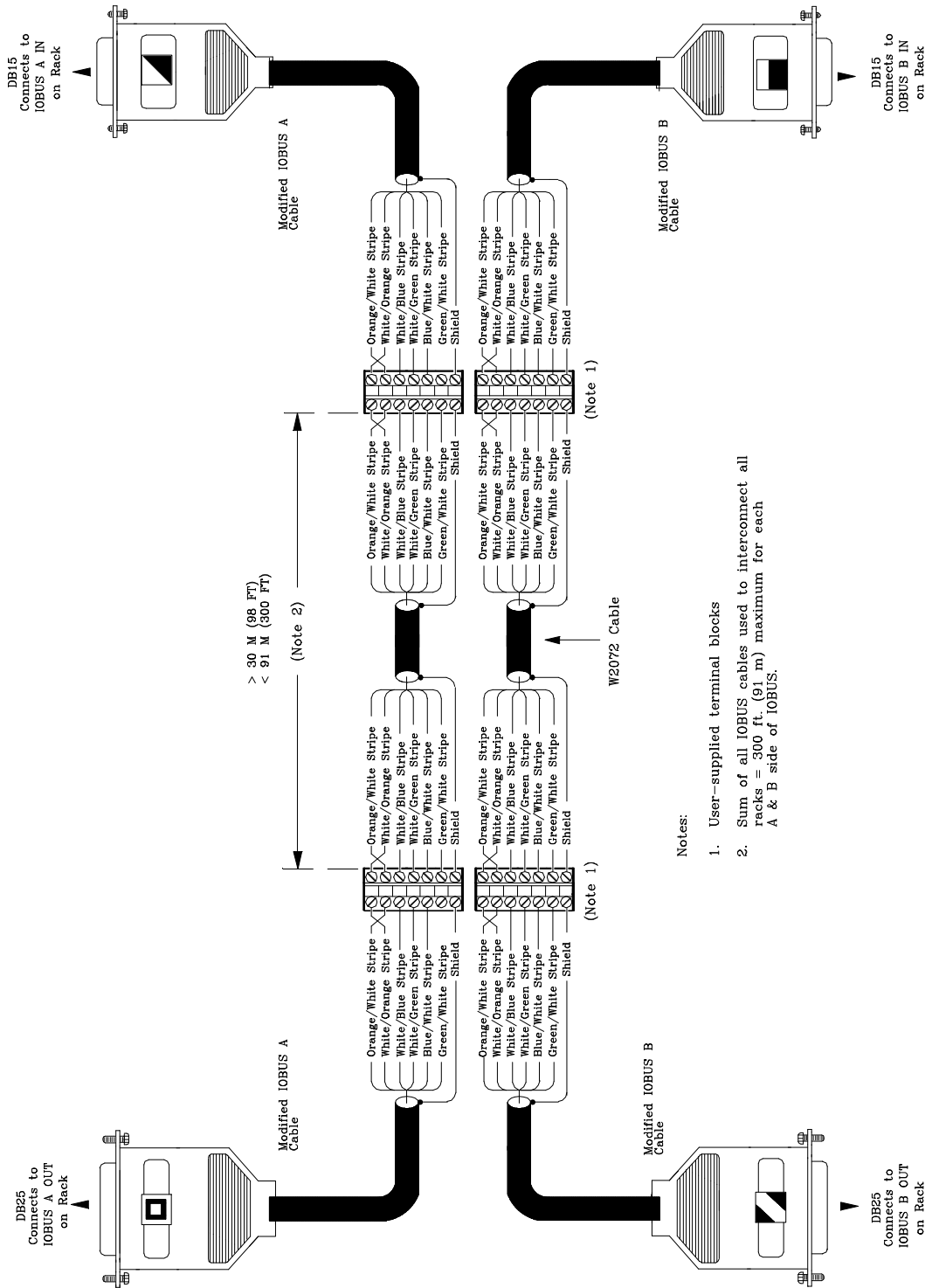
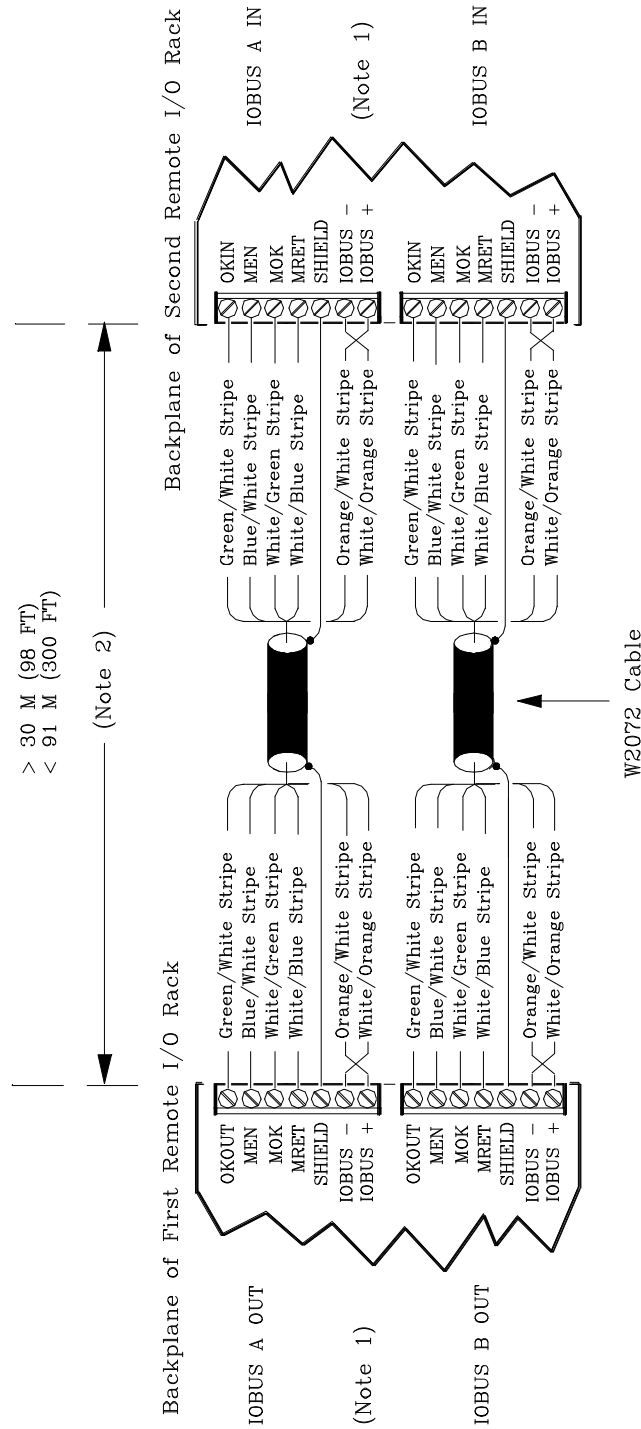

Figure 2-12 Terminal Block to Rack W2072 Cabling up to 300 ft. (91 m) for Redundant or Non-Redundant Systems



Notes:

1. Screw Terminals on Remote I/O Rack Backplane
2. Sum of all IOBUS cables used to interconnect all racks = 300 ft. (91 m) maximum for each A & B side of IOBUS.

Figure 2-13 Rack to Rack W2072 Cabling up to 300 ft. (91 m) for Redundant or Non-Redundant Systems

2.5.3. IOBUS Cable Connection up to 1500 ft. (460 m) for Non-Redundant APACS+ Systems Only

This section describes the preparation and installation of IOBUS cables for non-redundant APACS+ systems when the needed cable length exceeds the maximum standard length of 98.4 ft. (30 m) of factory-prepared IOBUS cables but is less than 1500 ft. (460 m). This procedure involves splicing of W2040 extension cables between two remotely located Remote I/O Racks, or between a Remote I/O Rack and another type of rack (e.g., MODULRAC or SIXRAC).

IMPORTANT

This section is applicable only to non-redundant APACS+ systems. See section 2.5.4 for non-redundant QUADLOG and rack-to-rack redundant QUADLOG and APACS+ systems.

The cable preparation procedure provided here involves splicing a custom-length cable that has unprepared ends. This kind of cable is type W2040. It is intended for use as an IOBUS extension cable between two Remote I/O Racks, or between another type of rack (e.g., MODULRAC or SIXRAC) and a Remote I/O Rack.

The Remote I/O Rack can accommodate either prepared or unprepared ends of available IOBUS cable(s). A prepared cable end has a molded connector on it and is to be plugged into the appropriate IOBUS IN or IOBUS OUT connector on the rack's backplane (see Figure 2-4). The wires emerging from an unprepared cable end are to be individually stripped and connected directly to the screw terminals of the associated IOBUS IN or IOBUS OUT terminal block, also located on the rack's backplane (see Figure 2-4).

When another type of rack (e.g., MODULRAC or SIXRAC) is also used, it requires a prepared cable end (with a connector) to attach that rack to the IOBUS. In these instances, you must supply DIN rail-mounted style terminal blocks (one for A side and one for B side). The terminal blocks are needed to transition between a W2040 unprepared cable end and another cable segment that has a prepared end (usually obtained by cutting a standard IOBUS cable in half). Each terminal block must be able to accommodate wire sizes of 16 to 28 AWG (1,3 mm² to 0.09 mm²).

IMPORTANT

It is important to preserve continuous cable impedance through all splice connections. This is to minimize signal reflections within the cable and help assure collision-free communications. After preparing cable ends, make sure each intended pair is re-twisted at the same intervals all the way to the screw terminals of the terminal blocks. Refer to Figures 2-15 and 2-16.

To connect a W2040 IOBUS cable between a terminal block and a Remote I/O Rack:

1. Determine the length of W2040 cable needed to connect from the terminal block location to the appropriate IOBUS connection point on the Remote I/O Rack's backplane. Allow slack for cable stripping, dressing, tagging, and strain relief at each end.
2. At the user-supplied terminal block, provide strain relief for the W2040 cable end. Connect the W2040 cable conductors (wires) to the terminal block as shown in Figure 2-15. Wire stripping and color code information for doing this are provided in Table 2-1 and Figure 2-14 respectfully.
3. At the appropriate IOBUS screw terminals on the Remote I/O Rack's backplane (Figure 2-4), provide strain relief for the W2040 cable end by securing it to one of the rack's tie points (Figure 2-5). Connect the W2040 cable conductors (wires) to the appropriate screw terminals. Tighten screw terminals by applying 78 in oz (0.55 Nm) of torque. Wire stripping and color code information for making connections are provided in Table 2-1 and Figure 2-14 respectfully.
4. Tag each W2040 cable end as needed for identification.

To connect a W2040 IOBUS cable between two Remote I/O Racks:

1. Determine the length of W2040 cable needed to connect from the first Remote I/O Rack to the second Remote I/O Rack. Allow slack for cable stripping, dressing, tagging, and strain relief at each end.
2. At the appropriate IOBUS OUT screw terminals on the first Remote I/O Rack's backplane (Figure 2-4), provide strain relief for the W2040 cable end by securing it to one of the rack's tie points (Figure 2-5). Connect the W2040 cable conductors (wires) to the screw terminals as shown in Figure 2-16. Tighten screw terminals by applying 78 in oz (0.55 Nm) of torque. Wire stripping and color code information for making connections are provided in Table 2-1 and Figure 2-14 respectfully.
3. At the appropriate IOBUS IN screw terminals on the second Remote I/O Rack's backplane (Figure 2-4), provide strain relief for the W2040 cable end by securing it to one of the rack's tie points (Figure 2-5). Connect the W2040 cable conductors (wires) to the screw terminals as shown in Figure 2-16. Tighten screw terminals by applying 78 in oz (0.55 Nm) of torque. Wire stripping and color code information for making connections are provided in Table 2-1 and Figure 2-14 respectfully.
4. Tag each W2040 cable end as needed for identification.

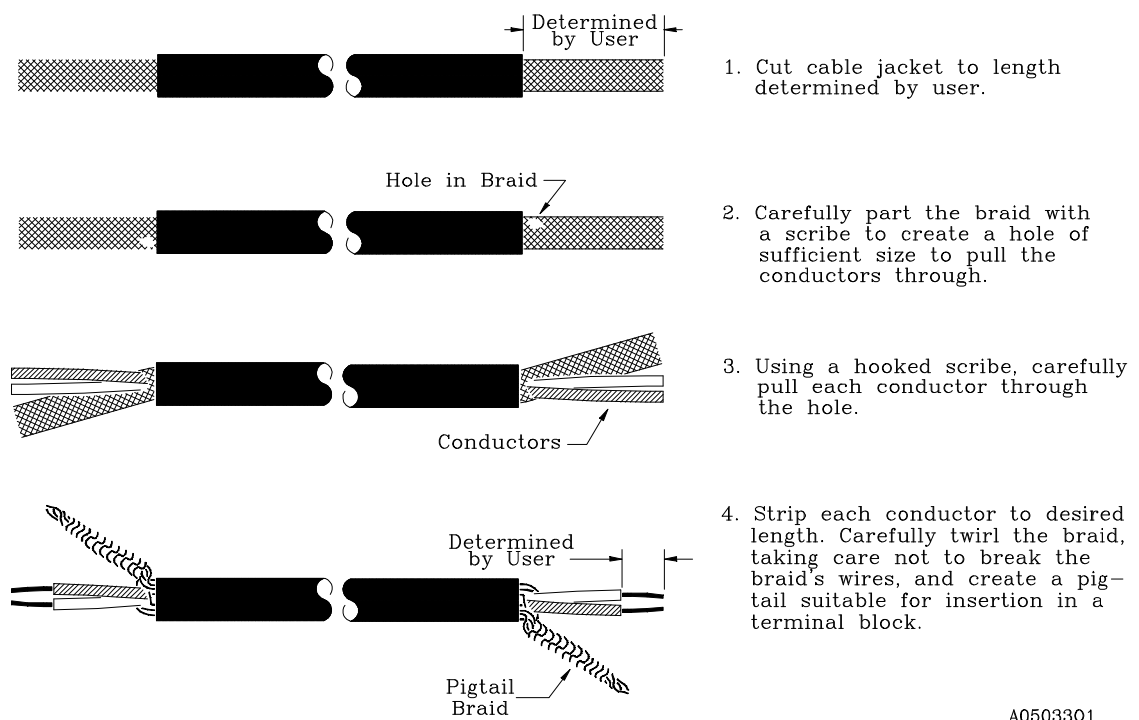

A0503301

Figure 2-14 W2040 Cable End Preparation

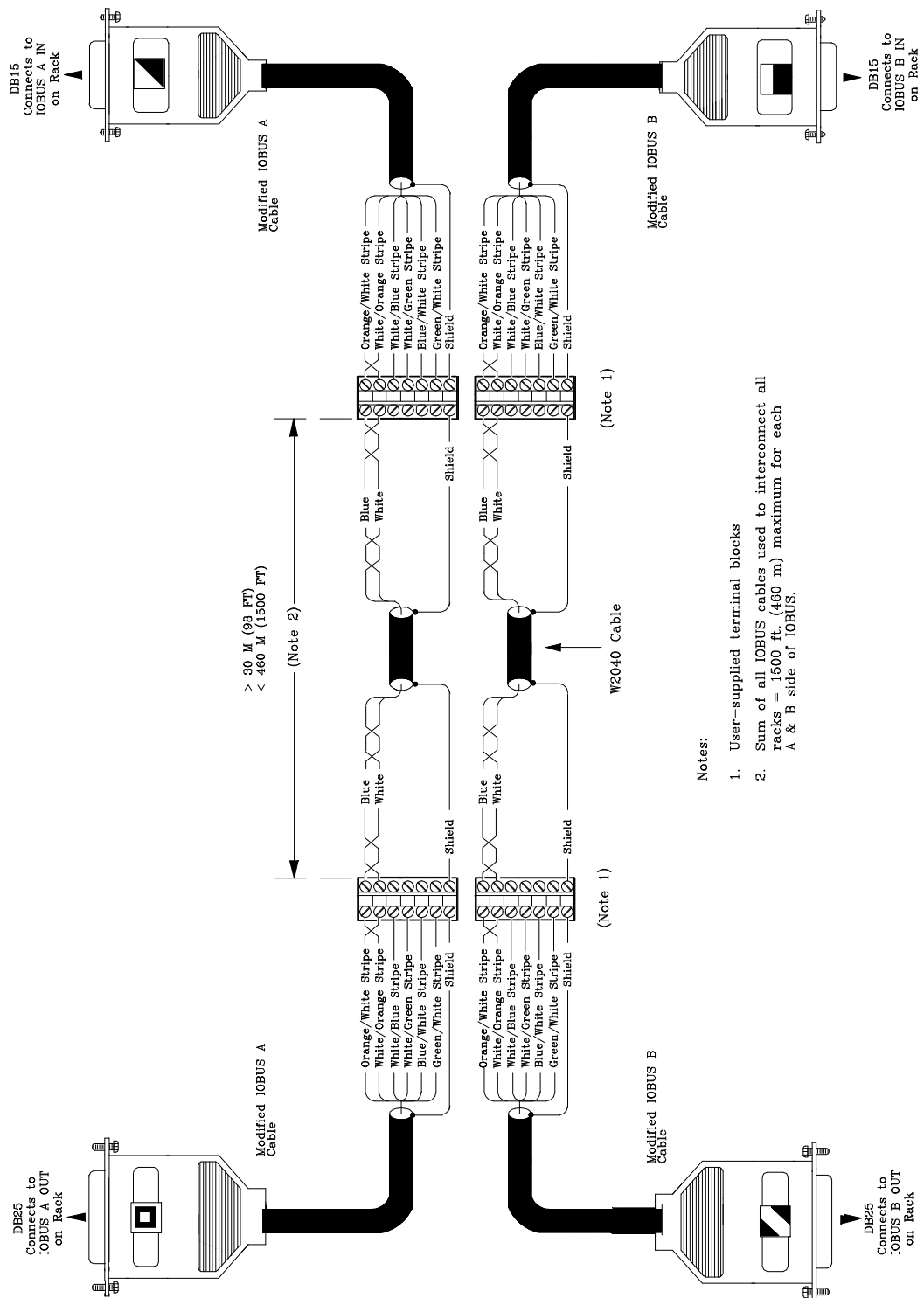

- Notes:
1. User-supplied terminal blocks
 2. Sum of all IOBUS cables used to interconnect all racks = 1500 ft (460 m) maximum for each A & B side of IOBUS.

Figure 2-15 Terminal Block to Rack W2040 Cabling up to 1500 ft. (460 m) for Non-Redundant APACS+ Systems

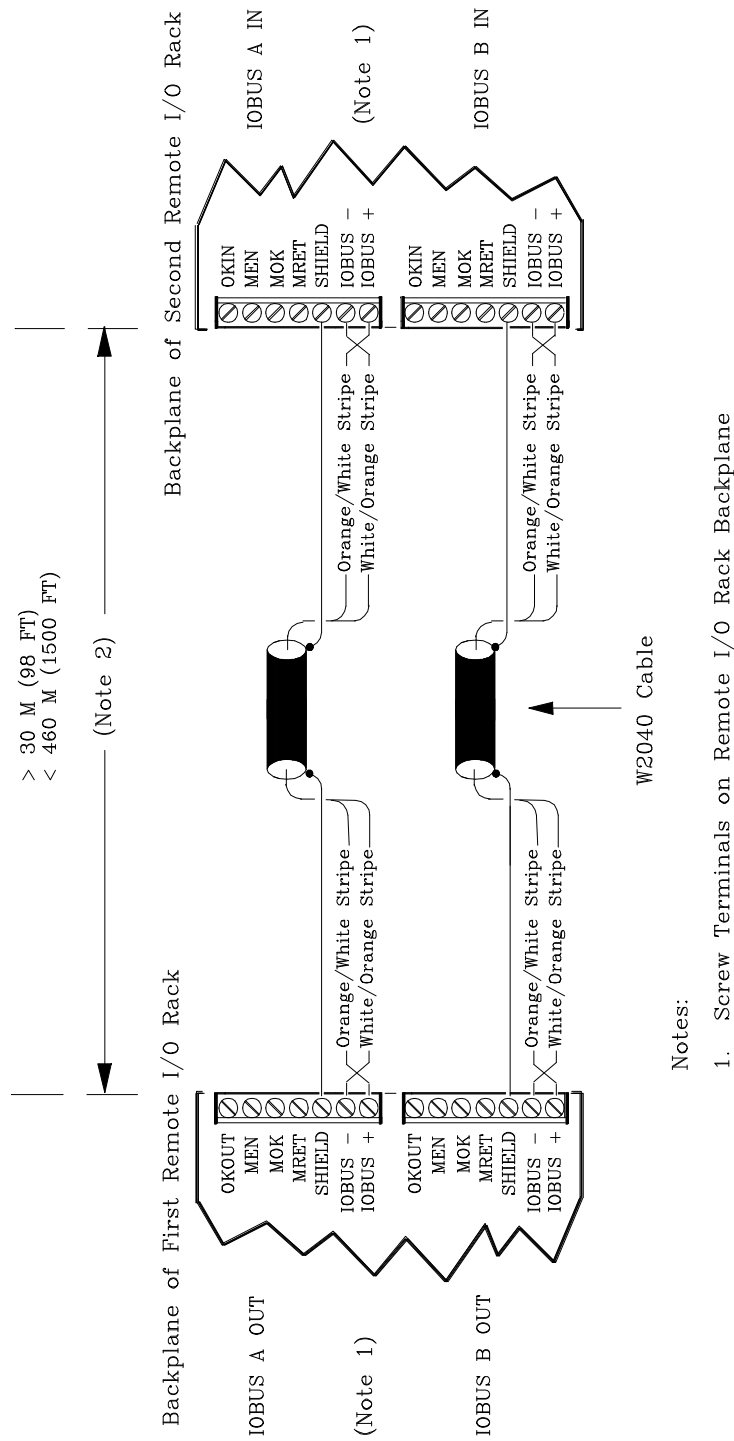

Figure 2-16 Rack to Rack W2040 Cabling up to 1500 ft. (460 m) for Non-Redundant APACS+ Systems

2.5.4 IOBUS Cable Connection up to 1500 ft. (460 m) for Rack-to-Rack Redundant APACS+ and all QUADLOG Systems

This section describes the preparation and installation of IOBUS cables for rack-to-rack redundant APACS+ or non-redundant and rack-to-rack redundant QUADLOG systems when the needed cable length exceeds the maximum standard length of 98.4 ft. (30 m) of factory-prepared IOBUS cables but is less than 1500 ft. (460 m). This procedure involves splicing of W2040 and Belden® 8627 extension cables between a Remote I/O Rack and another type of rack (e.g., MODULRAC or SIXRAC), or between two remotely located Remote I/O Racks.

The cable preparation procedure provided here involves splicing a custom-length cables that have unprepared ends. These kinds of cable are type W2040 and Belden 8627. They are intended for use as a IOBUS extension cables.

The Remote I/O Rack can accommodate either prepared or unprepared ends of available IOBUS cable(s). A prepared cable end has a molded connector on it and is to be plugged into the appropriate IOBUS IN or IOBUS OUT connector on the rack's backplane (see Figure 2-4). The wires emerging from an unprepared cable end are to be individually stripped and connected directly to the screw terminals of the associated IOBUS IN or IOBUS OUT terminal block, also located on the rack's backplane (see Figure 2-4).

When another type of rack (e.g., MODULRAC or SIXRAC) is also used, it requires a prepared cable end (with a connector) to attach that rack to the IOBUS. In these instances, you must supply DIN rail-mounted style terminal blocks (one for A side and one for B side). The terminal blocks are needed to transition between W2040 and Belden 8627 unprepared cable ends and another cable segments that has a prepared end (usually obtained by cutting a standard IOBUS cable in half). Each terminal block must be able to accommodate wire sizes of 16 to 28 AWG (1,3 mm² to 0.09 mm²).

IMPORTANT

It is important to preserve continuous cable impedance through all splice connections. This is to minimize signal reflections within the cable and help assure collision-free communications. After preparing cable ends, make sure each intended pair is re-twisted at the same intervals all the way to the screw terminals of the terminal blocks. Refer to Figures 2-18 and 2-19.

To connect W2040 and 8627 IOBUS cables between a terminal block and a Remote I/O Rack:

1. Determine the length of W2040 and 8627 cables needed to connect from the terminal block location to the appropriate IOBUS connection points on the Remote I/O Rack's backplane. Allow slack for cable stripping, dressing, tagging, and strain relief at each end.
2. At the user-supplied terminal blocks, provide strain relief for the W2040 and 8627 cable ends. Connect the W2040 and 8627 cable conductors (wires) to the terminal blocks as shown in Figure 2-18. Note that W2040 cable conductors are twisted together and shielded, but this is not required for 8627 cable conductors. Wire stripping and color code information for making connections are provided in Table 2-1 and Figures 2-14 and 2-17.

3. At the appropriate IOBUS screw terminals on the Remote I/O Rack's backplane (Figure 2-4), provide strain relief for the W2040 and 8627 cable ends by securing them to the rack's tie points (Figure 2-5). Connect the W2040 and 8627 cable conductors (wires) to the appropriate screw terminals. Tighten screw terminals by applying 78 in oz (0.55 Nm) of torque. Wire stripping and color code information for making connections are provided in Table 2-1, and Figures 2-14 and 2-17. Note that W2040 cable conductors are twisted together and shielded, but this is not required for 8627 cable conductors.
4. Make sure the conductors of each end of a W2040 or 8627 IOBUS extension cable matches up to identically color-coded conductors at the other end.
5. Tag each W2040 and 8627 cable end as needed for identification.

To connect W2040 and 8627 IOBUS cables between two Remote I/O Racks:

1. Determine the length of W2040 and 8627 cables needed to connect from the first Remote I/O Rack to the second Remote I/O Rack. Allow slack for cable stripping, dressing, tagging, and strain relief at each end.
2. At the appropriate IOBUS OUT screw terminals on the first Remote I/O Rack's backplane (Figure 2-4), provide strain relief for the W2040 and 8627 cable ends by securing them to the rack's tie points (Figure 2-5). Connect the W2040 and 8627 cable conductors (wires) to the screw terminals as shown in Figure 2-19. Tighten screw terminals by applying 78 in oz (0.55 Nm) of torque. Wire stripping and color code information for making connections are provided in Table 2-1, and Figure 2-14 and 2-17.
3. At the appropriate IOBUS IN screw terminals on the second Remote I/O Rack's backplane (Figure 2-4), provide strain relief for the W2040 and 8627 cable end by securing them to the rack's tie points (Figure 2-5). Connect the W2040 and 8627 cable conductors (wires) to the screw terminals as shown in Figure 2-19. Tighten screw terminals by applying 78 in oz (0.55 Nm) of torque. Wire stripping and color code information for making connections are provided in Table 2-1, and Figure 2-14 and 2-17.
4. Tag each W2040 and 8627 cable end as needed for identification.

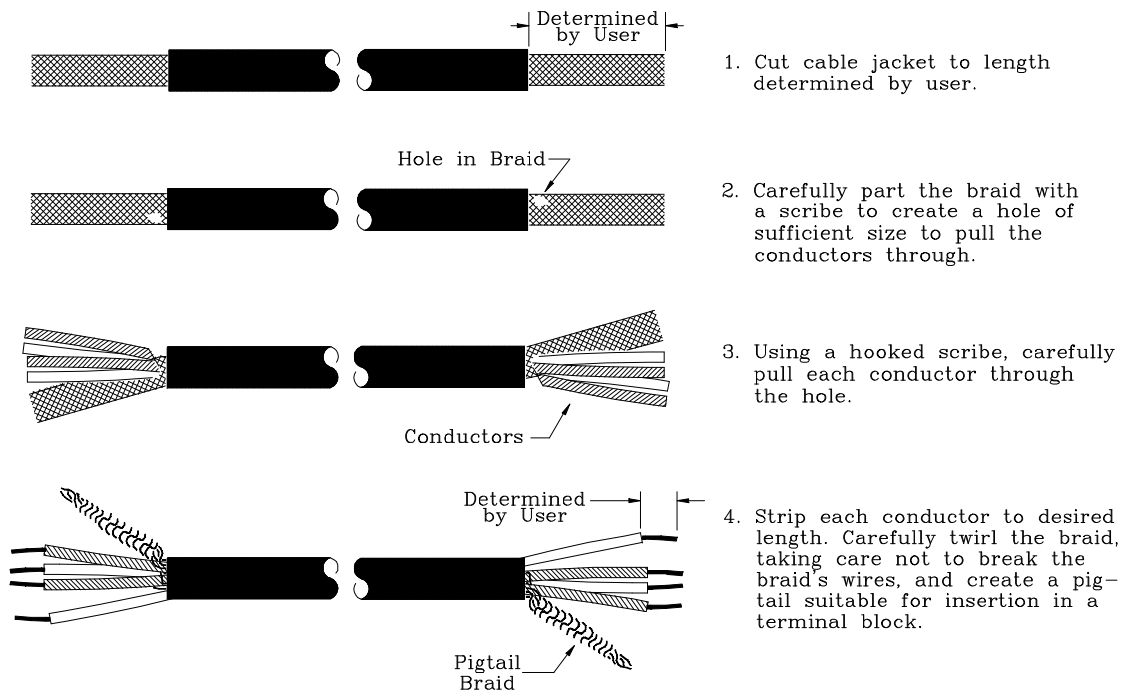

Figure 2-17 Belden 8627 Cable End Preparation

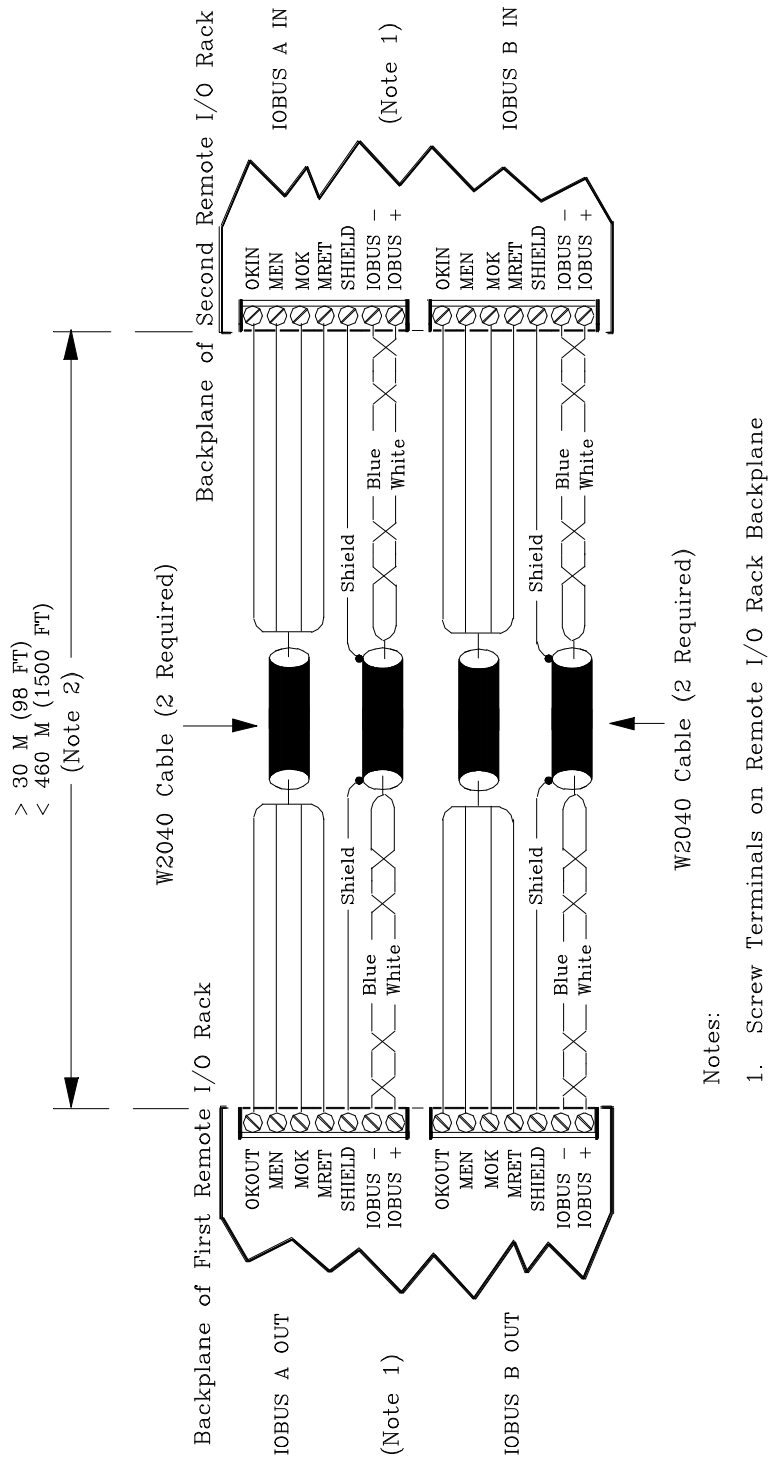

Figure 2-19 Rack to Rack W2040/8627 IOBUS Cabling up to 1500 ft. (460 m) for Node-to-Node Redundant APACS+ and All QUADLOG Systems

2.5.5 Modifying an IOBUS Cable

A standard IOBUS extension cable, shown in Figure 2-10, must be modified when the IOBUS must transition between a user supplied terminal block and the IOBUS IN or IOBUS OUT connection point on a rack's backplane that requires a factory-prepared cable end with a molded connector.

To modify an IOBUS A or B Cable:

1. Cut the Cable in half.
2. Prepare the cable ends as shown in Figure 2-20.

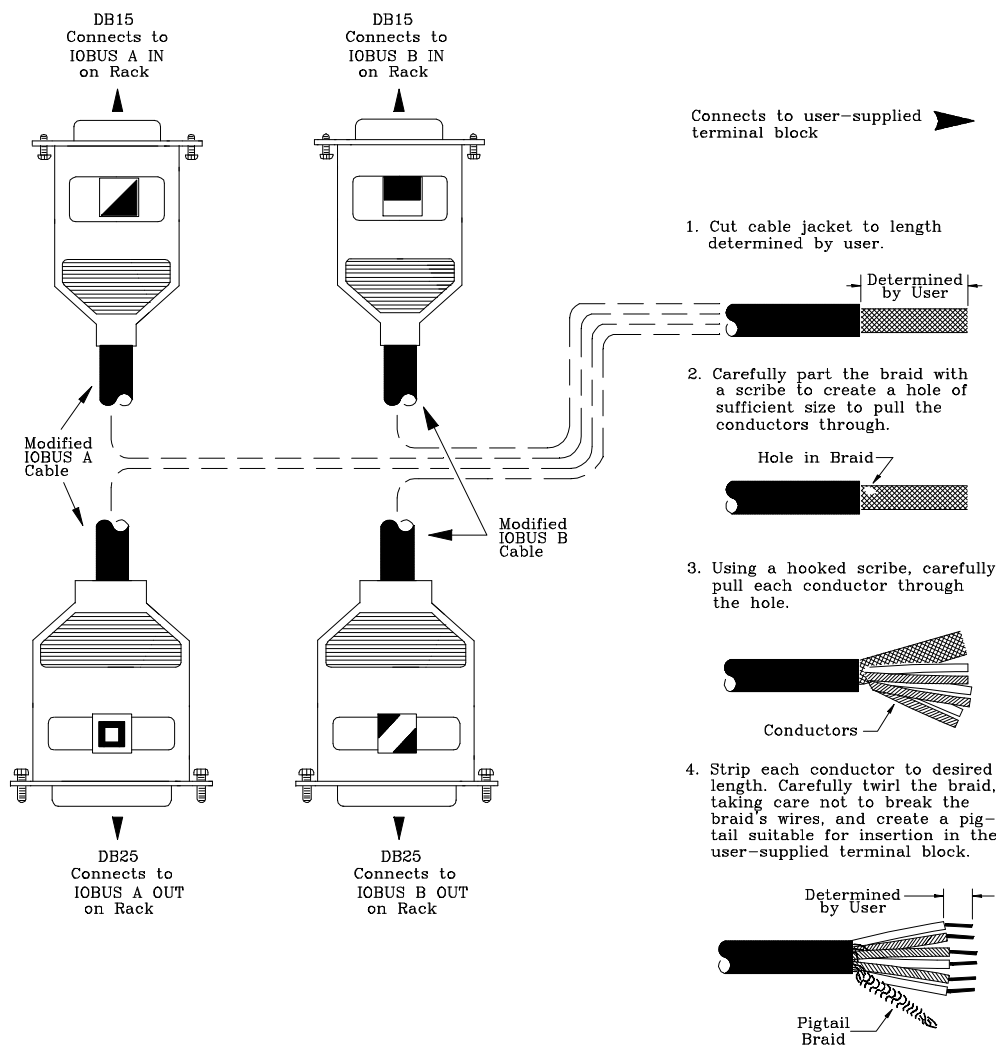

Figure 2-20 Modifying an IOBUS Cable

2.5.6 Remote I/O Rack IOBUS Shunt

This section describes the IOBUS shunt and how to use it in conjunction with a Remote I/O Rack. Since the layout of an IOBUS also involves other types of racks (i.e., MODULRAC or SIXRAC) refer to their Installation and Service Instructions for using IOBUS shunts with them.

IOBUS shunt installation must precede the installation of I/O modules. A Remote I/O Rack provides IOBUS connections on each end of its backplane as shown in Figures 2-4 and 2-9. On the right side of the Remote I/O Rack's backplane, there is one IOBUS shunt socket designated W4. The W4 designation is printed on the backplane underneath the removable IOBUS shunt. The shunt is secured to the backplane via its captive mounting screw. The shunt must be oriented to either continue the IOBUS to another rack or terminate the IOBUS at an end of the backplane on the Remote I/O Rack.

The following details are provided to assist in determining the orientation of the IOBUS shunt:

- The removable IOBUS shunt is a two-position device. The shunt's label indicates its two possible orientations as shown in Figures 2-4, 2-9, and 2-21.
- If the shunt is oriented so "I/O BUS CONTINUE" is positioned on top, the IOBUS will be continued from the Remote I/O Rack's backplane to another rack.
- If the shunt is oriented so "I/O BUS TERMINATE" is positioned on top, the IOBUS is terminated at the right side of the Remote I/O Rack. The shunt terminates the IOBUS in its characteristic impedance.

2.5.7 IOBUS Attenuators

When the IOBUS is 30 meters or longer in length, one to three attenuators must be installed. The total length of the IOBUS determines the quantity of attenuators required. One attenuator (part number 16405-1) is supplied with each Remote I/O Rack. The use of attenuators is a precaution to prevent signal reflections from interfering with IOBUS communications in the event one side of the IOBUS (A or B) is unintentionally disconnected or severed in a plant or process environment.

Physically, an attenuator resembles a shunt as shown in Figure 2-21. Either type can be secured to a rack's backplane using its captive mounting screw; however, they differ electrically. Unlike a shunt, an attenuator is only to be installed in one orientation (i.e. the I/O BUS CONTINUE orientation). When an attenuator is to be installed on a specific Remote I/O Rack, it replaces a shunt in the W4 socket located on the right side of a rack's backplane.

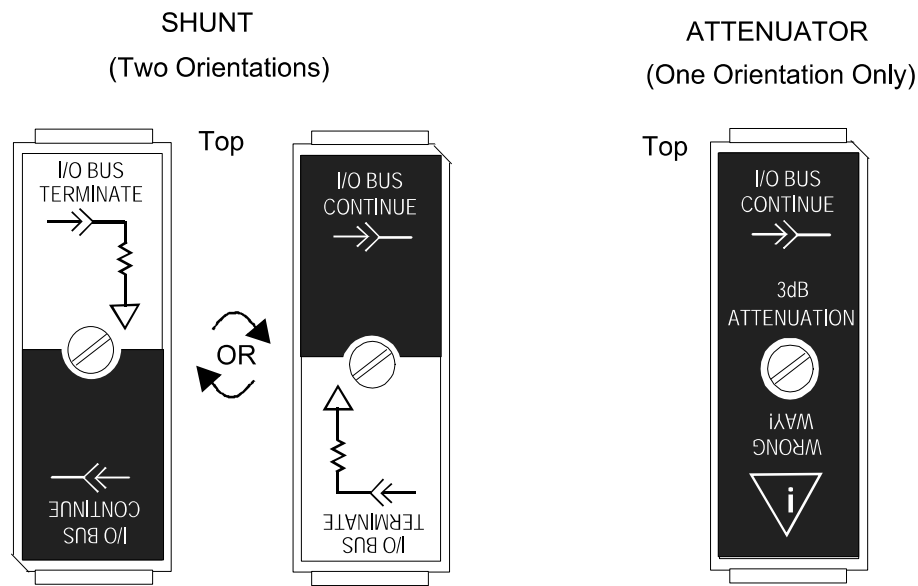

Figure 2-21 Shunt and Attenuator Orientations

To install one or more attenuators:

1. Locate the rack at the far end of the IOBUS. This is the non-control module end of the IOBUS. Use this point to start measurements.
2. Measure 30 meters along the IOBUS towards the control module. From that point, continue progressing along the IOBUS until a rack is encountered.
3. Remove the shunt from the W4 socket (Remote I/O Rack) or W10 socket (MODULRAC or SIXRAC) on the rack's backplane and replace it with a properly oriented attenuator.
4. Repeat steps 2 and 3 as long as there is another 30-meter or longer segment of the IOBUS remaining towards the control module or until three attenuators have been installed.



CAUTION

Do not install more than three attenuators on an IOBUS.

As an example, when the procedure is applied to the IOBUS shown in Figure 2-22, the shunt in rack B was replaced with an attenuator.

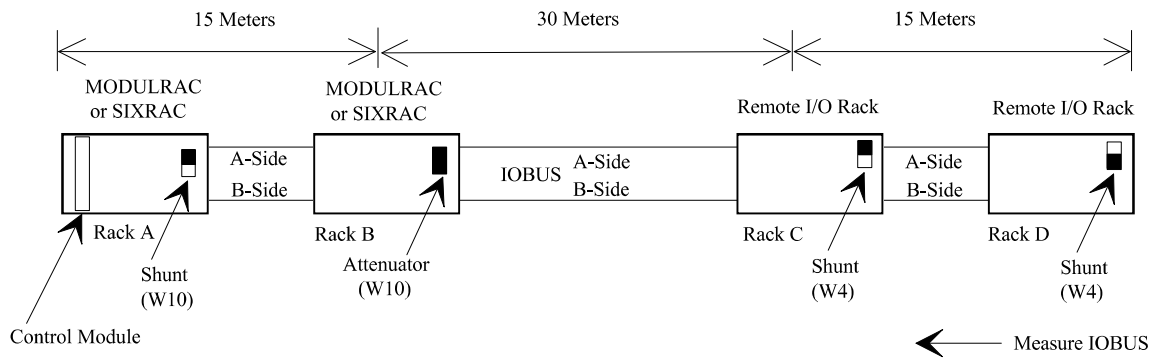

Figure 2-22 Example IOBUS with Attenuator Installed

2.5.7.1 IOBUS Considerations for System Expansion

When an existing IOBUS is expanded by one or more Remote I/O Racks, change the original IOBUS shunt and attenuator orientations, as required, to accommodate the new IOBUS arrangement.

2.5.8 Setting OK Loop Jumpers W1 to W3

The OK Loop is an IOBUS redundancy signal line that daisy chains from connector to connector across the backplane. It routes through each module plugged into the rack. It enters a module as a serial input (OKIN) and exits as a serial output (OKOUT) from the same module. The OKOUT from a lower slot module becomes the OKIN to the next higher module in the chain and so on. Backplane jumpers W1 to W3 (Figures 2-23 and 2-24) connect the OKOUT signals from module slot connectors to IOBUS MOK (Module OK) signals. The Loop continues through socket W4 (IOBUS shunt) when the shunt is oriented in the IOBUS CONTINUE position (Figure 2-21), and continues on to the IOBUS A OUT and IOBUS B OUT connectors and screw terminals on the right side of the backplane (Figure 2-4).

During system operation, the actual OK Loop signal (1.4 mA constant current source) originates from and is monitored by the control module to verify that all modules are plugged in and operating. An error and redundancy switchover signal results if a break is suddenly detected in the loop. For example, a break occurs if someone removes a module from the rack while it is operating.

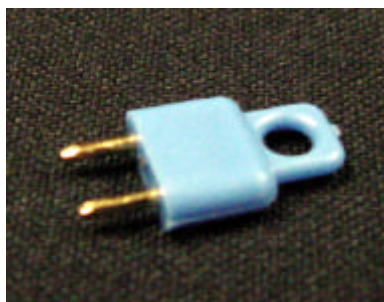

Figure 2-23 Example OK Loop Jumper

Setting OK Loop jumpers W1 to W3 must precede the installation of modules. An empty Remote I/O Rack has all the jumpers installed (default) by the factory. As shown in Figure 2-24, a jumper is to be removed if a module is to occupy the next higher slot.

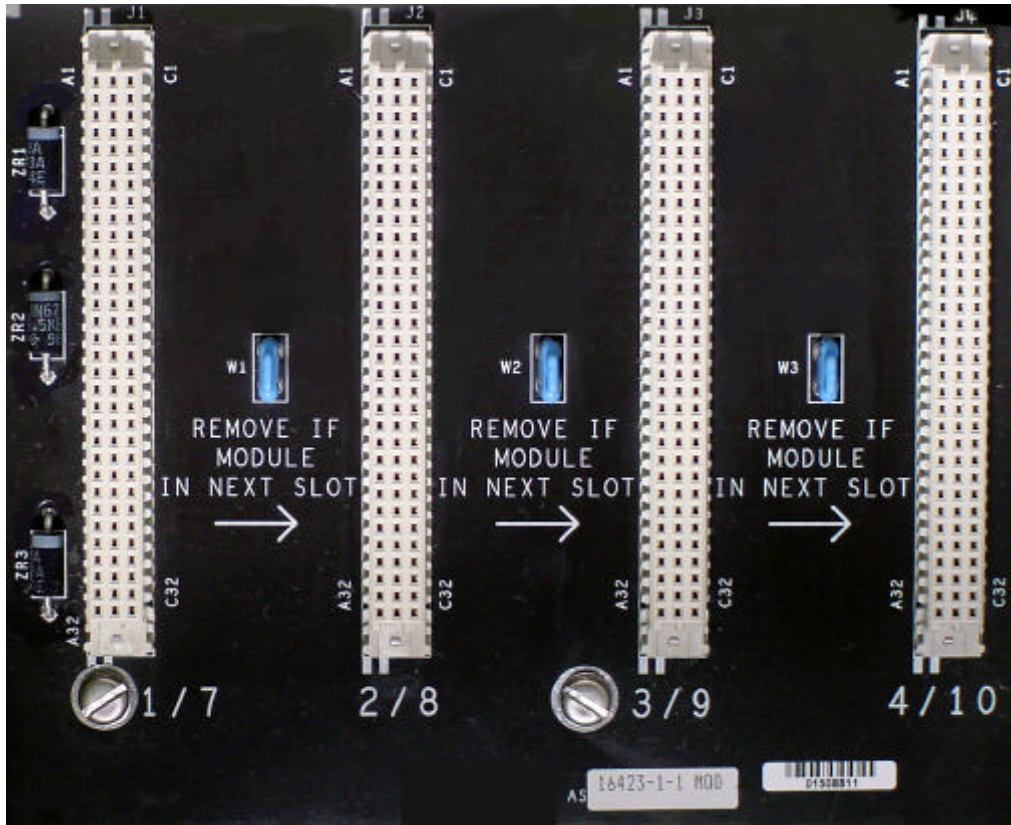

Figure 2-24 OK Loop Jumpers on Backplane

2.6 Rack Address Switch Setting

Addressing within an APACS+ or QUADLOG system requires that each rack be assigned a unique rack address. The Rack Address thumbwheel switch (SW1), located on the upper right side of the Remote I/O Rack’s backplane (Figure 2-25), is used to assign an address (1 to 16) to the rack. The address is used for software identification of I/O modules during system operation. The Rack Address switch is to be set in conjunction with the Slot Address switch described in section 2.7.

The Rack Address switch must be set when the Remote I/O Rack is off-line and powered-down. Only during a module’s power-up sequence will it scan for and accept the Remote I/O Rack’s address setting.

To set the Rack Address switch (SW1):

1. Locate the Rack Address switch on the backplane (Figure 2-25). The switch setting is visible through a window near the top of the switch.
2. Consult system drawings to identify the rack address (1 to 16).
3. Rotate SW1's thumbwheel to set the unique rack address (1 to 16).

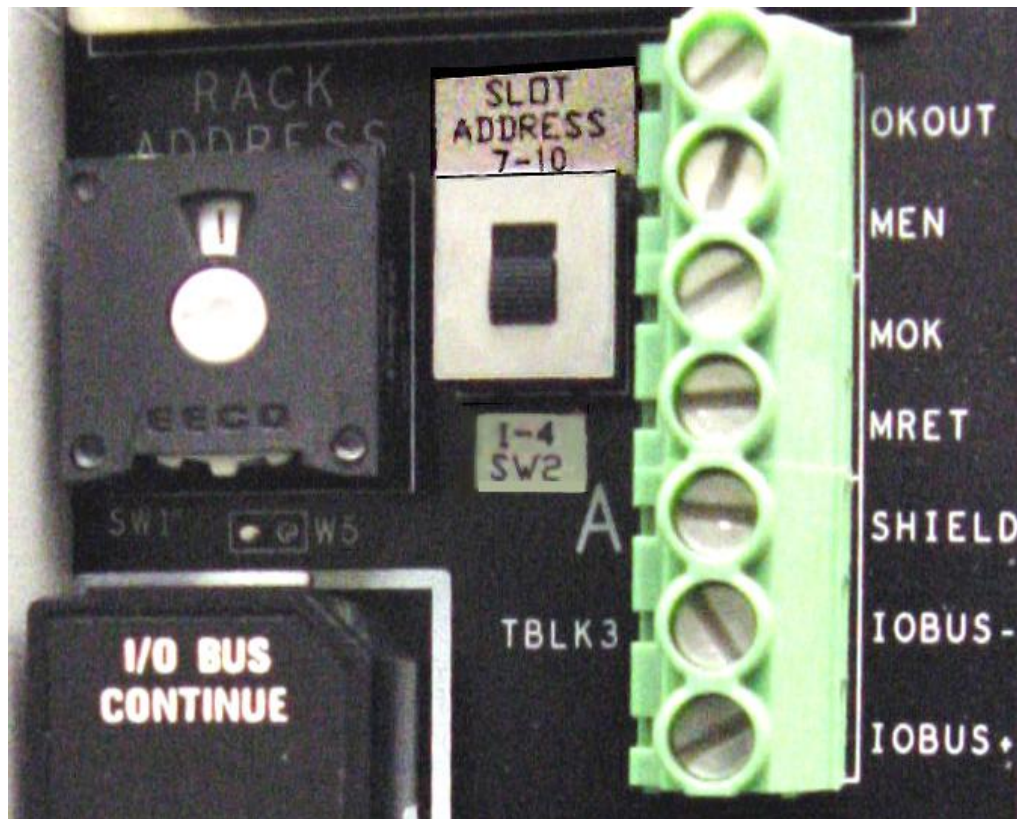

Figure 2-25 Rack Address and Slot Address Switches

2.7 Slot Address Switch Setting

The Slot Address switch (SW2), located on the upper right side of the Remote I/O Rack's backplane (Figure 2-25), is a slide switch used to set whether the Remote I/O Rack is to occupy lower slot addresses (1 to 4) for standalone use, or upper slot addresses (7 to 10) when used as an extension to another rack such as a SIXRAC. This is the reason each slot position is double-marked on the rack's backplane as shown in Figure 2-24. For example, the first slot is double-marked 1/7.

IMPORTANT

When the Remote I/O Rack is to be used as an extension of another rack, such as SIXRAC, both the Remote I/O Rack and the other rack **must have the same** Rack Address switch setting. In addition, the Remote I/O Rack's Slot Address range switch (SW2) **must** be set in the 7-10 position. If SW2 is set incorrectly, it may cause IOBUS communications anomalies and prevent the process from going on-line.

The Slot Address switch must be set when the Remote I/O Rack is off-line and powered-down. The Slot Address switch is to be set in conjunction with the Rack Address switch described in section 2.6.

To set the Slot Address switch:

1. Locate the Slot Address switch (SW2) on the backplane (Figure 2-25). It is a two-position slide switch.
2. Consult system drawings to identify the slot address range (1-4 or 7-10) of the Remote I/O Rack.
3. Set SW2 to the 1-4 or 7-10 (default) slot address position as needed.

2.8 Recirculating Fan Power Cable Connection

The Remote I/O Rack has two built-in 24 Vdc recirculating fans located under the module housing area of its chassis. A bottom view of the chassis is shown in Figure 2-26. A fan power cable exits the right side of the chassis. It has an unterminated end with three stripped wires for connection to a 24 Vdc power source. The wiring color code is as follows:

- Red (+)
- Black (-)
- Green (Ground)

Connect the fan's power cable to a 24 Vdc power source. It is recommended that the fan's 24 Vdc power source be separate from the 24 Vdc power source(s) used to power the rack's I/O modules to keep electrical motor noise away from the rack's backplane.



Electrical shock hazard. Remove power from all involved wires and terminals before making connections.



Figure 2-26 Bottom View of Rack Showing Built-in Recirculating Fans

2.9 DC Power Bus Connections

Triplicate power buses supply 24 Vdc operating power to the rack's I/O modules from up to three independent power sources. Power is applied to each of the power bus connectors by a user-installed cable from either an externally mounted power supply, such as a Siemens Moore POWERAC, or a user-supplied power supply. The power bus connectors are located on the left side of the Remote I/O Rack's backplane and are identified as P1 (24V A), P2 (24V B), and P3 (24V C) as shown in Figure 2-4. Power bus connector pinouts are shown in Figure 2-27. A power supply cable (P/N 16137-60) compatible with the Remote I/O Rack and POWERAC (and other power supplies) is available from Siemens Moore (Figure 2-28). One cable is required for each power supply.



Electrical shock hazard. Remove power from all involved wires and terminals before making connections.

If using the Siemens Moore Power Supply Rack (POWERAC), refer to its Installation and Service Instruction (SD39PSR-1) for connection details.

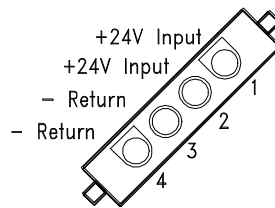

Figure 2-27 Pinout of Power Bus Connector

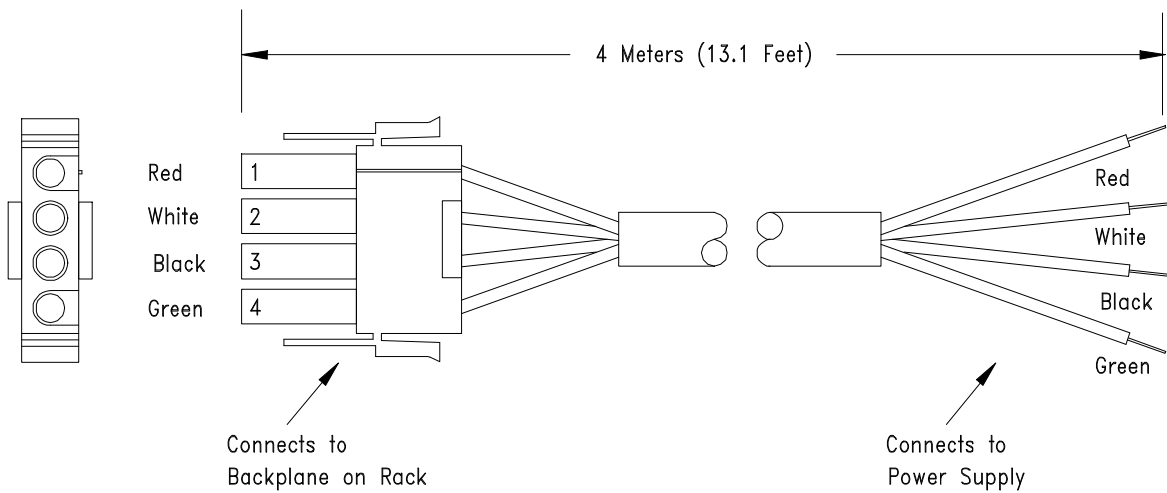

Figure 2-28 Power Supply Cable

2.10 Terminal Block Connections

Use the following recommendations to prepare various conductors (wire ends) for connection to terminal blocks.

Twisted Pair Connections

Twisted pair connections made to terminal blocks (as used to splice IOBUS cables) requires special attention. It is important to preserve the continuous cable impedance as transition is made at the terminal block from one cable to another. Provision of continuous impedance through all splice connections minimizes signal reflections, thus assuring collision-free communications. To preserve the inherent cable impedance, make sure that after preparing the cable ends as shown in Figures 2-12 through 2-19. Each intended pair is re-twisted at the same intervals all the way to the wire connectors of the terminal block.

Stranded Wire Connections

Stripped ends of stranded or solid wires must not be soldered or tinned in preparation for use with DIN rail terminal blocks. Solder is a malleable material and can loosen, causing open connections. Also, corrosion to the terminal block can result from the pickling agents or flux used with solder.

Torque Specifications

Use the following torque specifications when tightening connections in DIN rail terminal blocks:

- LMI (gray) DIN rail terminal blocks: 3.5 to 5.5 in. lbs.
- Phoenix (green) DIN rail terminal blocks: 6.5 to 8.5 in. lbs.

2.11 Protective Conductor Terminal Connection

The Remote I/O Rack has two protective conductor terminals (ground lugs) located just below the left (Figure 2-29) and right sides of its backplane. Optional ground wires can be connected from this terminal to safety ground as shown in Figure 2-3. The symbol shown in Figure 2-29 and described in Table 1-1 is located adjacent to the terminal. Refer to APACS+ Grounding Practices (document number SD39GND-1) for safety ground recommendations.



Figure 2-29 Protective Conductor Terminal

2.12 I/O Cable Installation

Each I/O module to be installed in the Remote I/O Rack is to connect to its I/O field wiring via an Interconnect I/O Cable Assembly. Each cable extends from a module slot position in the Remote I/O Rack to a companion marshalled termination assembly that provides I/O field terminals. The Remote I/O Rack can accommodate up to four cable assemblies. Installation of these cable assemblies, as shown in Figure 2-30, is commonly performed at the time of rack installation (prior to module installation).

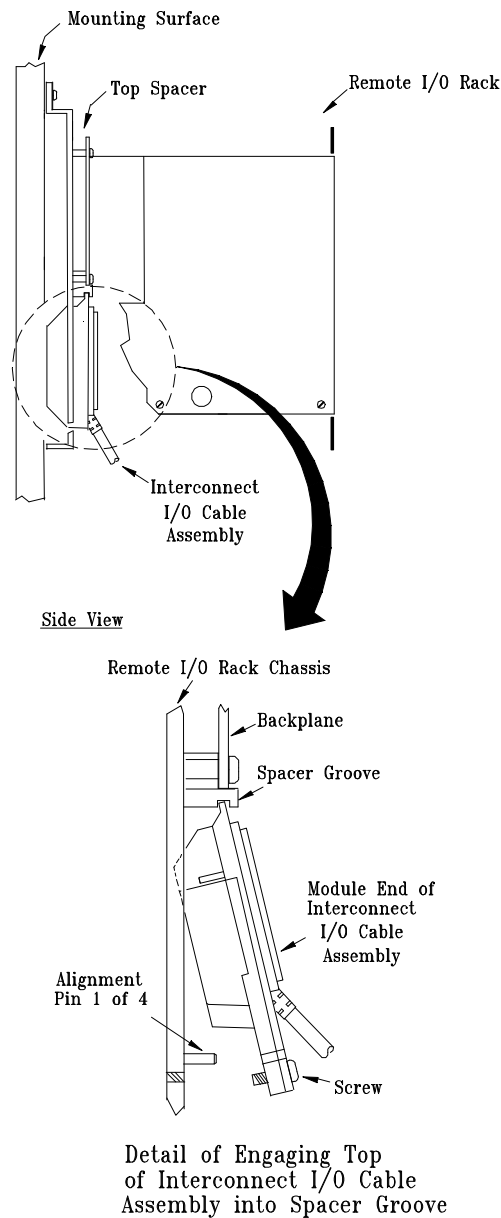

Figure 2-30 Installing Module End of I/O Interconnect Cable

To install the module end of an I/O cable:

1. Feed the I/O cable end up into the Remote I/O Rack through the bottom opening.
2. As shown in Figure 2-30, tilt the I/O cable's top connector edge into the rack's spacer groove and then pivot the connector down so it engages the alignment pin on the rack's chassis and protrudes through the connector cutout in the rack's chassis.
3. When the connector is properly seated, secure it to the rack with its captive mounting screw.

2.13 Module and Rack Keying

Each module slot in the Remote I/O Rack must be mechanically keyed to assure only a specific type of module can be plugged into a given slot. Keying creates a physical interface between a specific slot in the rack and a specific type of I/O module. Keying is performed on the top and bottom of the rack's bezel at each slot position. Keying is highly recommended since it enhances system safety and aids in preventing equipment damage.

Generally, modules are keyed at the factory. The keying pattern is unique to each module type (e.g., Standard Analog Module, Critical Analog Module).

Each Remote I/O Rack involved in the factory staging of a system is keyed at the factory. The installer must key racks not keyed at the factory. Each slot must be keyed according to the module type assigned. Keying is performed with keying pins and stop plugs. Keying pins are supplied with the module while stop plugs are supplied with the rack.

When adding a module to a Remote I/O Rack, be sure to key its slot at installation time.

The specific keying pattern for a slot is detailed in the **module's** documentation. For example, to key a slot for a Critical Analog Module (CAM), look up the necessary keying pattern in the CAM's Installation and Service Instruction.

The details in Figure 2-31 show how keying is implemented between an I/O module and a Remote I/O Rack. A variation of this image is provided in the documentation for each module.

#

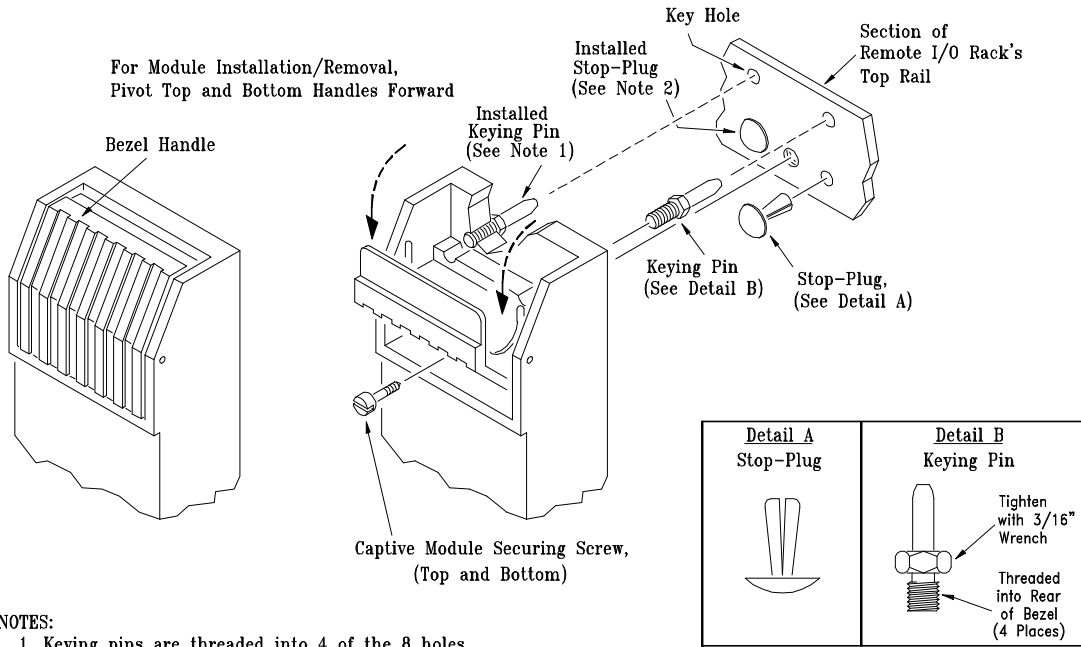

NOTES:

1. Keying pins are threaded into 4 of the 8 holes in the rear top and bottom sections of the module's bezel. Refer to module's documentation for specific keying pattern to be used.
2. Plastic stop-plugs are pressed into top and bottom rail holes at a each slot position to match a keyed module to that slot.

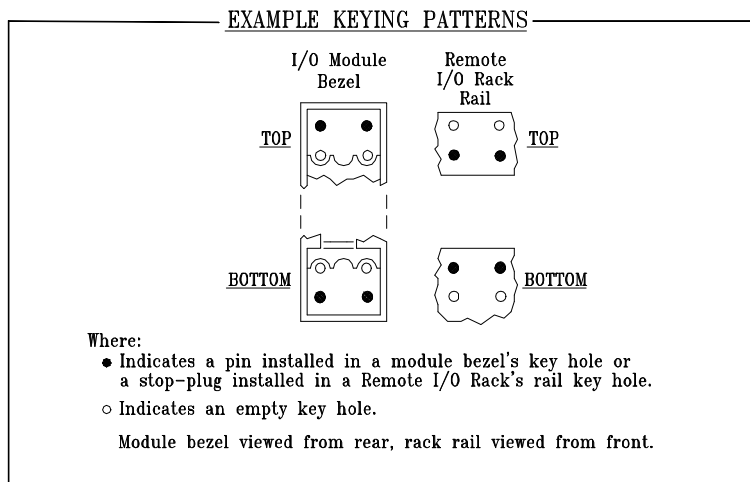

Figure 2-31 Rack and I/O Module Keying

3.0 Maintenance

The Remote I/O Rack requires minimal maintenance. Some routine maintenance is recommended in the form of a visual inspection and possible cleaning.

3.1 Visual Inspection

The Remote I/O Rack and installed I/O modules should be subjected to a periodic visual inspection. The frequency of inspection will depend on the severity of the operating environment.

The primary aim of the inspection is to reveal any excessive accumulation of dust, dirt, or other foreign material. Accumulation of dirt and dust prevents efficient heat dissipation and may cause system failure or equipment breakdown.

3.2 Cleaning

Cleaning a Remote I/O R involves brushing or vacuuming to restore cooling efficiency that may have been degraded by accumulated dust. Be careful not to disturb wiring and jumpers on associated hardware. The fans should also be carefully cleaned. Cleaning of I/O modules and associated hardware is discussed in module documentation.

3.3 Parts Replacement

Refer to Figures 1-1, 2-3, and 2-26 for major parts identification. When servicing a Remote I/O Rack, the removal of installed I/O modules and their associated hardware is sometimes necessary, refer to the module documentation for module removal and replacement procedures.

3.3.1 Fan Fuse Replacement

The fan fuse (P/N 7447-171) is a 1.5 A 250 Volt 5x20 mm type M fuse in a spring loaded fuse holder. A small flat blade screwdriver is need to open/close the fuse holder.

To replace the fan fuse:

1. Locate the fan fuse holder on the left side of the Remote I/O Rack's chassis (Figure 2-3).
2. Remove power to the fan at its external power supply.
3. Using a small flat blade screwdriver, remove the twist cap from the fuse holder and remove the fuse.
4. Replace the fuse and install the cap to the fuse holder.
5. Restore power to the fan assembly and check for fan proper operation.

3.4 Recommended Spare and Replacement Parts

There are no recommended spare parts for the Remote I/O Rack. A replacement Remote I/O Rack and any of its accessories, attachments, and options can be ordered from one of the addresses in the Warranty statement or through your local Siemens Moore representative. Part numbers for these items are provided in section 5.

3.5 Return of Equipment Within North America

To return a Remote I/O Rack:

1. Call the Repair Order Group at (215) 646-7400, ext 4RMA (4762) weekdays between 8:00 a.m. and 4:45 p.m. eastern time to obtain an RMA number. Mark the RMA number prominently on the outside of the shipment.
2. When calling for an RMA number, provide the reason for the return. If returning equipment for repair, failure information (e.g., error code, failure symptom, installation environment) will be requested. Supply a purchase order number for non-warranty repairs.

Material Safety Data Sheet

A Material Safety Data Sheet (MSDS) must be included with each item being returned that was stored or used anywhere hazardous materials were present.

Packaging

Package the Remote I/O Rack in its original shipping materials. Otherwise, package it for safe shipment or contact the factory for shipping recommendations. An I/O module must be placed inside a static shielding bag to protect it from electrostatic discharge.

3.6 Return of Equipment Outside of North America

Contact the appropriate Siemens Moore product support group listed in section 1.2 of this document. Provide the reason for the return and request equipment packaging and shipping instructions. For non-warranty repairs, supply a purchase order number.

#

4.0 Circuit Description

The Remote I/O Rack contains no active circuitry. It provides a passive backplane that contains various components, some of which are listed here:

- Rack Address switch (SW1) enables setting a unique rack address (1 to 16).
- Slot Address range switch (SW2)
- Module Connectors (J1 to J4) mate with an I/O module's P1 connector for access to DC operating power and IOBUS communication signals.
- A and B IOBUS IN and OUT connectors and screw terminals provide for the connection of the IOBUS rack-to-rack cables.
- A, B, and C (P1, P26, and P3) DC power supply connectors provide for the connection of external DC operating power to the installed I/O modules.
- IOBUS Shunt (W4) continues the IOBUS to another rack or terminates IOBUS in its characteristic impedance.
- OK Loop jumpers (W1 to W3) preserve the continuity of the OK Loop signal when an I/O module is not installed at that particular slot.

4.1 Communications

A redundant serial communication bus is employed on the Remote I/O Rack's backplane. This is the IOBUS, which runs at 1 Mbps and uses a single line with a clock encoded data signal.

The IOBUS uses a differential line transceiver system where transceivers located in I/O modules are connected to these buses. Additionally, the IOBUS is isolated by 1:1 isolation transformers located in each module that connects to IOBUS.

4.2 IOBUS Signals

Redundancy signals are functional in a node-to-node (rack-to-rack) redundant system. These signals are constantly monitored the control module located on the IOBUS to determine if a switchover to the redundant system should occur. Redundancy signals are not applicable to non-redundant systems.

The IOBUS is comprised of the following signals:

- **IOBUS A+/A- and IOBUS B+/B-** These differential pairs carry the communications between the control module and its associated I/O modules. They are bused across the Remote I/O Rack's backplane and continue through the IOBUS Shunt (I/O Bus Continue position) and connect to the IOBUS A/B IN/OUT connectors or screw terminals located at each end of the rack's backplane.
- **MEN (Master Enable)** This redundancy signal line is bused across the backplane and continues through the IOBUS Shunt (I/O Bus Continue) and connects to the IOBUS A/B IN/OUT connectors and screw terminals. The MEN line is terminated when an IOBUS Shunt is in the "I/O Bus Terminate" position. The control module sources this signal with an FET tied to +5V. I/O modules place an opto-

coupler diode across this line and the MRET line. If the MEN signal causes the opto-coupler to conduct, the module is enabled and its I/O channels can be energized.

- **MRET (Master Enable Return)** This redundancy signal line is bused across the backplane and continues through the IOBUS Shunt (I/O Bus Continue) and connects to the IOBUS A/B IN/OUT connectors and screw terminals. The MRET line is terminated when an IOBUS Shunt is in the “I/O Bus Terminate” position. The line is tied to common in the originating control module and provides a “ground-loop free” return for each I/O module.
- **OKIN (and OKOUT)** This redundancy signal line is daisy-chained from module connector to module connector across the backplane as a serial input (OK IN) to a module and serial output (OK OUT) from the same module. The OK OUT from a module becomes the OK IN to the next module in the chain. It continues through IOBUS Shunt (I/O Bus Continue) and connects to the IOBUS A/B IN/OUT connectors and screw terminals. Each module has an opto-isolator transistor that connects the OKIN and OKOUT lines, if the module is OK, forming one long continuity loop. The signal (1.4 mA constant current source) originates in the control module and loops back onto the MOK line at the right-hand termination point of the IOBUS. The OKIN/OUT signal is jumpered to the MOK line by an IOBUS Shunt in the “I/O Bus Terminate” position or by an installed OK Loop jumper. The control module reads the state of MOK to determine if any of the modules on IOBUS are not OK.
- **MOK (Master OK or Module OK)** This redundancy signal return line gives the result of the OK continuity string. The line is bused across the backplane and continues through the IOBUS Shunt (I/O Bus Continue) and connects to the IOBUS A/B IN/OUT connectors. The line is isolated from the IOBUS A/B IN/OUT connectors and screw terminals and is jumpered to the OKOUT redundancy line when an IOBUS shunt is in the “I/O Bus Terminate” position. When this line is open, the control module is signaled that one or more modules are not OK.

4.3 DC Power Bus

The Remote I/O Rack has a tripled DC power bus. DC power is supplied to the rack from one to three external power supplies. They connect to the rack via backplane connectors P1, P2, and P3 to supply 24 Vdc to the backplane. The tripled bus is arranged as A BUS, B BUS, and C BUS from which installed I/O modules receive operating power.

Each DC bus is tapped by an I/O module through separate pins in the module’s backplane connector (P1) and applied to the anodes of A BUS, B BUS, and C BUS diodes located within the module’s circuitry. The cathodes of all three diodes are connected (diode ORed) to create a common power bus for the circuit card. When redundant power supplies are installed, diode OR-ing assures continued operating power in the event of power supply failure or removal.



5.0 Accessories, Attachments, and Options

5.1 Accessories

Table 5-1 lists the accessories for the Remote I/O Rack.

TABLE 5-1 Remote I/O Rack Accessories

Part Number	Description
16137-60 (single piece)	Power Supply Cable. Connects Remote I/O Rack to 24 Vdc power supply.
16056-593	M-BUS/IOBUS Cable Adapter Kit. Converts connector spring latch type security to screw lock type security (and vice versa)

5.2 Attachments

Table 5-2 lists the attachments that are provided with each Remote I/O Rack.

TABLE 5-2 Remote I/O Rack Attachments

Part Number	Description
16056-384	Remote I/O Rack Keying Kit. A bag containing 24 stop plugs to mechanically interface I/O modules to the Remote I/O Rack. Kit comes attached to the rack.
14784-9 (single piece)	Jumpers W1 to W3 (OK Loop). Factory installed in the backplane assembly.
16066-21 (single piece)	IOBUS Shunt Module Assembly (W4). Factory installed in the backplane.
16405-1 (single piece)	IOBUS Attenuator Module Assembly. Included with rack.

5.3 Options

Table 5-3 lists the options for the Remote I/O Rack. Consult your system drawings to determine the quantity and types of optional cables required. The Remote I/O Rack requires a selection of terminated or unterminated Interconnect I/O Cable Assemblies and a selection of IOBUS A/B cables. If fiber optics are involved, a Fiber Optic Expander (IFX) and fiber optic cable are required.

TABLE 5-3 Remote I/O Rack Options

Part Number	Description
16137-156	IOBUS A Cable 6.6 ft. (2 m)
16137-143	IOBUS B Cable 6.6 ft. (2 m)
16137-145	IOBUS A Cable 13.1 ft. (4 m)
16137-148	IOBUS B Cable 13.1 ft. (4 m)
16137-146	IOBUS A Cable 49.2 ft. (15 m)
16137-149	IOBUS B Cable 49.2 ft. (15 m)
16137-147	IOBUS A Cable 98.4 ft. (30 m)
16137-150	IOBUS B Cable 98.4 ft. (30 m)
W2040-(length)	IOBUS Cable - Unterminated Belden type #9860 (non-redundant system only)
W2072-(length)	IOBUS Cable - Unterminated Belden type #9843 (redundant & non-redundant systems)
16137-122	Interconnect I/O Cable Assembly 5.7 ft. (1.75 m)
16137-114	Interconnect I/O Cable Assembly 10 ft. (3 m)
16137-115	Interconnect I/O Cable Assembly 26.2 ft. (8 m)
16137-116	Interconnect I/O Cable Assembly 49.2 ft. (15 m)
16137-117	Interconnect I/O Cable Assembly 98.4 ft. (30 m)
16137-118	Unterminated Interconnect I/O Cable Assembly 10 ft. (3 m)
16137-119	Unterminated Interconnect I/O Cable Assembly 26.2 ft. (8 m)
16137-120	Unterminated Interconnect I/O Cable Assembly 49.2 ft. (15m)
16137-121	Unterminated Interconnect I/O Cable Assembly 98.4 ft. (30 m)
16114-148/149	Fiber Optic Expander (IFX). Refer to Instruction SD39IFX-1 for cable part numbers and other details.

6.0 Specifications

This section lists mechanical, environmental, and electrical specifications for the Remote I/O Rack.

6.1 Mechanical Specifications

Table 6-1 lists the mechanical specifications for the Remote I/O Rack.

Table 6-1 Remote I/O Rack Mechanical Specifications

Specification	Value
Module Capacity	Four APACS+ or QUADLOG I/O Modules
Rack Dimensions	Refer to Figure 2-2
Rack Weight (w/o modules)	8.14 lbs. (3.69 kg)

6.2 Environmental Specifications

Table 6-2 lists the environmental specifications for the Remote I/O Rack.

Table 6-2 Remote I/O Rack Environmental Specifications

Category	Specification	Value
Temperature	Operating Temperature	-25°C to 70°C (-13°F to 158°F)
Humidity	Operating Humidity	5% to 95% RH Non-condensing
Temperature	Storage Temperature	-25°C to 85°C (-13°F to 185°F)

6.3 Electrical Specifications

Table 6-3 lists the electrical specifications for the Remote I/O Rack.

Table 6-3 Remote I/O Rack Electrical Specifications

Specification	Parameter	Value
IOBUS Architecture	Physical Structure	Redundant A and B Buses
	IOBUS Length, Node-to-Node Redundant APACS+ or QUADLOG System	1500 ft. (460 m) maximum (Extendable with fiberoptics)
	IOBUS Length, Non-Redundant APACS+ System	1500 ft. (460 m) maximum (Extendable with fiberoptics)
	Data Transmission Rate	1 Mbps
	Media Specification	IEEE RS-485
	Media Access	Master to Slave
	IOBUS Capacity	1 control module plus up to 39 I/O modules
Rack Address	Address Number	1 to 16; Set by Thumbwheel Switch (SW1)
Slot Address	Slot Range	1-4 standalone or 7-10 extension rack, Set by Slot Address Switch (SW2)
Recirculation Fans	Air Displacement	25 to 40 cfm
	Input Voltage	24 Vdc
APACS+ or QUADLOG I/O Module Input Power	Backplane Power Bus A	24 Vdc $\pm 10\%$
	Backplane Power Bus B	24 Vdc $\pm 10\%$
	Backplane Power Bus C	24 Vdc $\pm 10\%$

6.4 Electrical Classification

This section lists safety agency ratings for the Remote I/O Rack.

6.4.1 Safety Agency Approvals

Table 6-4 lists safety agency approvals.

IMPORTANT

Before installing, applying power to, or servicing a Remote I/O Rack, see the unit's nameplate label for electrical classification.

Table 6-4 Agency Approvals

Agency	Standard	Standard Title
ABS	ABS Rules Part 4, Section 11, Table 4/11.1 (1995)	Environmental Tests for Control and Monitoring Equipment
CSA	C22.2 No.213-M1987	Non-Incendive Electrical Equipment for use in Class I, Div 2 Hazardous Locations
CSA	C22.2 No.142-M1987	Process and Control Equipment for Non-Hazardous Locations
FM	FM Class 3611	Electrical Equipment for use in Class I, Div 2; Class II, Div 2; and Class III, Div 1 and 2 Hazardous Locations
FM	FM Class 3810	Safety Standards for Electrical and Electronic Test, Measuring, and Process Control Equipment
FM	FM Class 3600	Electrical Equipment for Use in Hazardous (Classified) Locations
UL	UL 503	Industrial Control Equipment

6.5 Electromagnetic Compatibility (EMC)

This product has been tested per the European Union's EMC Directive. Refer to section 2.2.1 for considerations affecting EMC compliance.



