

E96-413

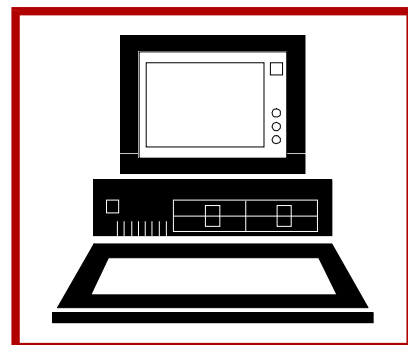

Instruction

Multi-Function Controller Termination Modules (NIMF01 and NIMF02)

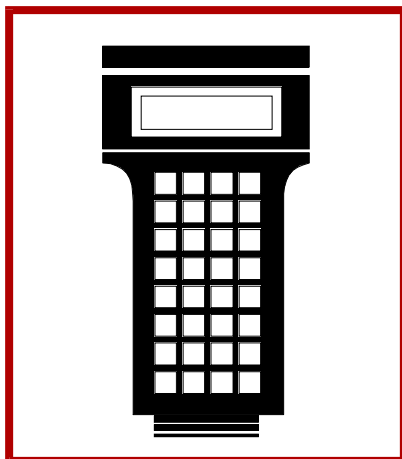
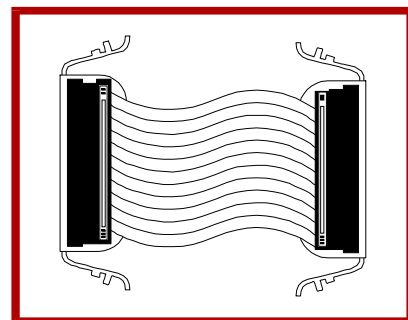
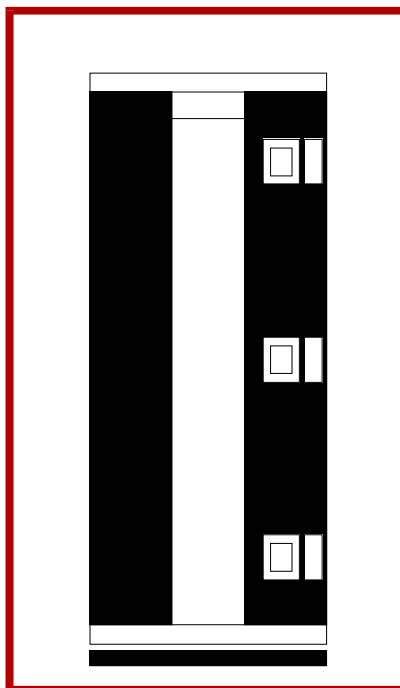
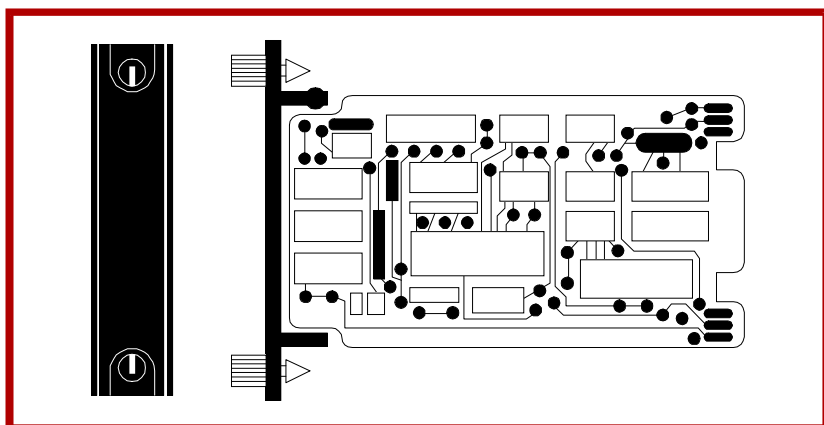
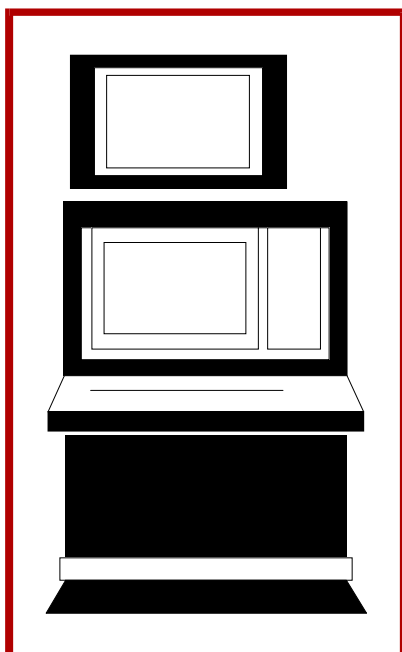

SECTION 1 - INTRODUCTION

OVERVIEW

The NIMF01 Multi-Function Controller Termination Module terminates two RS-232-C ports for the IMMFC03 Multi-Function Controller, INICT01 INFI-NET to Computer Transfer Module, INPPT01 Plant Loop to Plant Loop Transfer Module and INPCT01 Plant Loop to Computer Transfer Module. When terminating an IMMFC03 module, it enables the IMMFC03 module to communicate to a computer, terminal, printer or sequential events recorder through the serial ports (see Figure 1-1). It also provides a serial link for a NDCS03 Digital Control Station or IISAC01 Analog Control Station through a NICS01 Control I/O Termination Module. The IMMFC04 and IMMFC05 Multi-Function Controllers). use the NIMF01 termination mod-

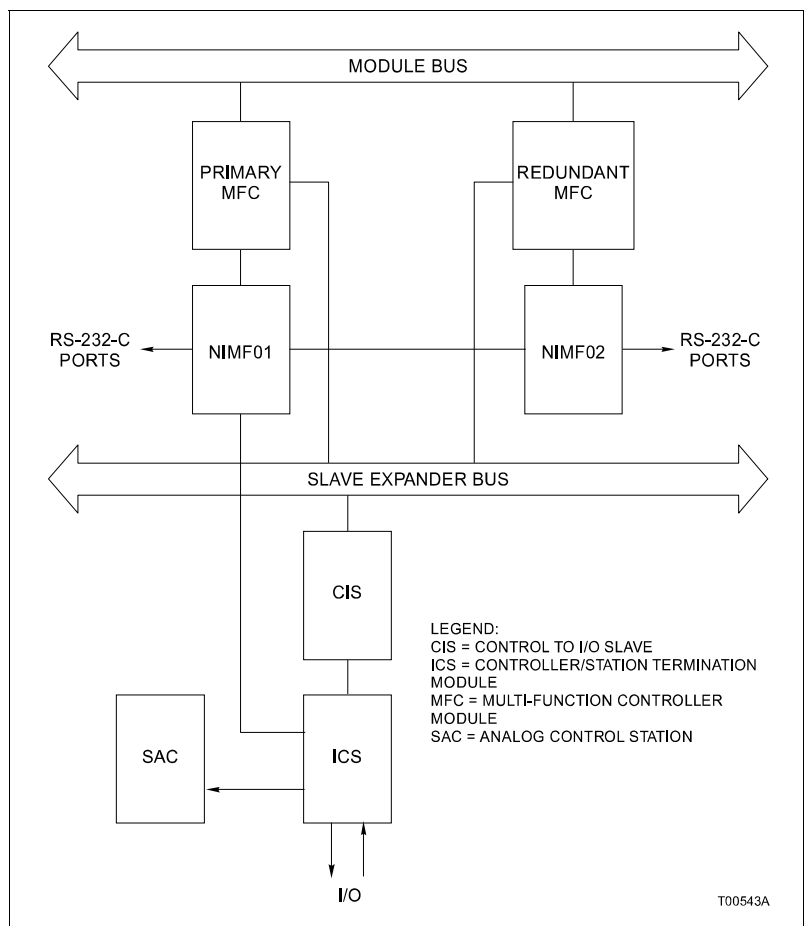

Figure 1-1. Example Redundant IMF Termination Module Application

ule to terminate a station link and connect to a redundant controller.

The NIMF02 termination module is used in addition to the NIMF01 termination module when terminating redundant modules. Figure 1-1 shows an example redundant MFC application. Figure 1-2 shows an example Plant Loop to computer interface application. Figure 1-3 shows an example Plant Loop to Plant Loop interface application. The NIMF02 has on-board relays that allow one MFC module to communicate over the RS-232-C link during redundant operation.

INTENDED USER

System engineers and technicians should read this manual before installing and placing the multi-function controller termination module (IMF) into operation. **Do not** put the IMF module into operation until this instruction is read and understood.

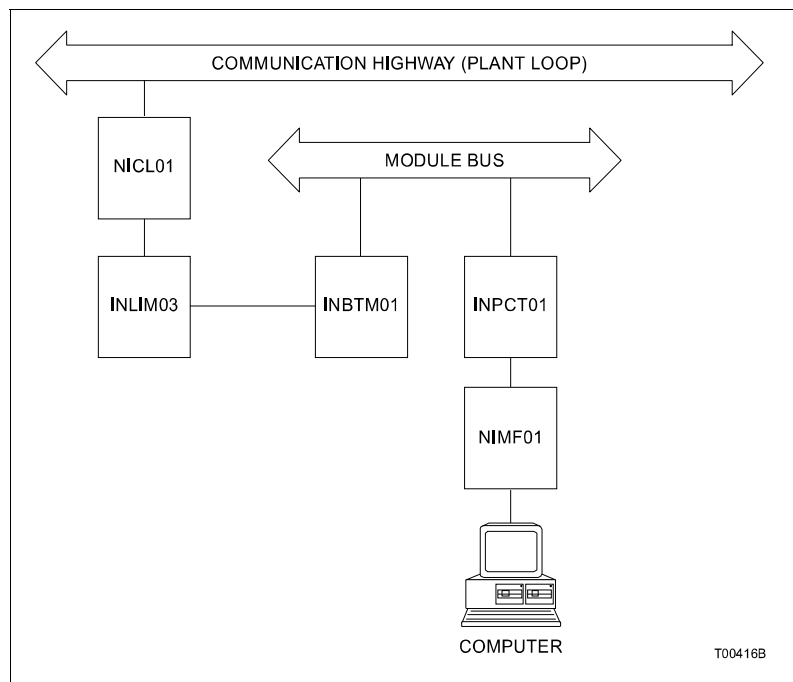

Figure 1-2. Example Plant Loop to Computer Interface Application

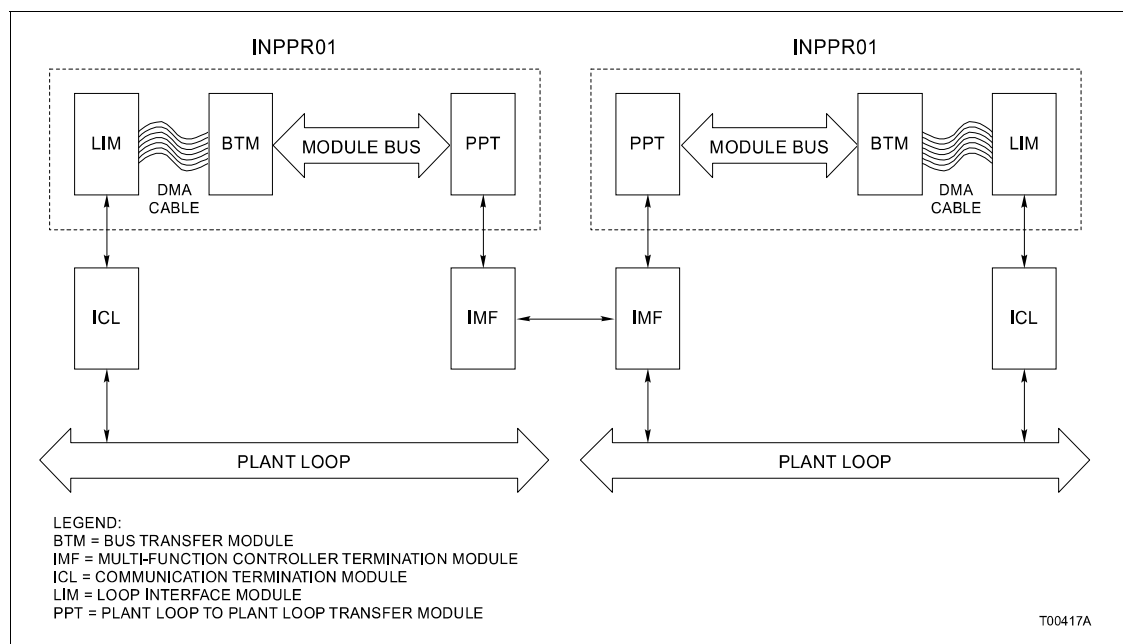

Figure 1-3. Example Plant Loop to Plant Loop Interface Application

MODULE DESCRIPTION

The IMF module is a single printed circuit board that uses one slot in an NTMU01 or NTMU02 Termination Mounting Unit (TMU). The board contains:

- Two DB-25 connectors.
- Relays (NIMF02 only).
- Connector sockets.
- Dipshunts.
- Light emitting diode (LED).
- Power terminals.
- Serial link terminals (NIMF01 only).

FEATURES

The IMF termination modules provide serial communication ports for modules. Dipshunts allow the termination module to be configured for operation as DTE or DCE. There is one serial link on the NIMF01 termination module that provides a communication link from a module to an analog control station or digital control station.

HARDWARE APPLICATION

The IMF termination module is a passive device that terminates the connection of RS-232-C cables from a controller or communication module to a field device (e.g., printer, computer terminal, sequence of events recorder or modem). The computer allows a user to enter control strategies, do module configurations, establish a point table and monitor module status through the computer. Board design gives redundant modules access to both serial ports as well as the serial link to the NICS01 which connects to a NDCS03 Digital Control Station or IISAC01 Analog Control Station.

INSTRUCTION CONTENT

This manual consists of five sections and six appendices.

Introduction	Contains an overview of the features, specifications and a description of the IMF termination module.
Installation	Describes precautions to observe when handling modules and setup procedures required before module operation. This section discusses dipswitch settings and installation procedures.
Maintenance	Provides a maintenance schedule.
Repair/Replacement Procedures	Details how to replace an IMF termination module.
Support Services	Describes the support services (spare parts, training, documentation, etc.) available from Bailey Controls Company.
Appendices	Briefly discuss the modules that use the IMF termination modules and provide a cross-reference of dipswitch and jumper settings for those modules.

HOW TO USE THIS MANUAL

Read this manual through in sequence. Read the installation section thoroughly. Do the steps in order. Complete all steps in the installation section before operating the IMF termination module. Refer to the table of contents or index to find specific information after the module is operating.

GLOSSARY OF TERMS AND ABBREVIATIONS

Table 1-1 lists definitions of the terms and abbreviations used in this instruction.

Table 1-1. Glossary of Terms and Abbreviations

Term	Definition
DCE	Data communication equipment or data circuit terminating equipment. equipment that establishes and terminates a communication link between two devices. In RS-232-C communication systems, the DCE nomenclature indicates the signals that appear at specified cable connection contacts. A modem is an example of this type of device.
Dipshunt	Dual in-line package with shorting straps.
DTE	Data terminal equipment. Equipment comprising the data source, data sink or both that provides the communication control function. In RS-232-C communication systems, the DTE nomenclature indicates the signals that appear at specified cable connection contacts. Terminals and printers are examples of this type of device.
MMU	Module mounting unit. A card cage that provides electrical and communication support for INFI 90/Network 90 [®] modules.
PCB	Printed circuit board.
TM	Termination module. Provides input/output connection between plant equipment and the INFI 90/Network 90 modules.
TMU	Termination mounting unit. A card cage that provides housing for INFI 90/ Network 90 termination modules.

REFERENCE DOCUMENTS

Table 1-2 lists the documents referenced in this instruction.

Table 1-2. Reference Documents

Number	Document Title
I-E93-902	NDCS03 Digital Control Station
I-E96-117	IISAC01 Analog Control Station
I-E96-211	IMMFC03 Multi-Function Controller Module
I-E96-212	IMMFC04 Multi-Function Controller Module
I-E96-213	IMMFC05 Multi-Function Controller Module
I-E96-500	Site Planning and Preparation
I-E96-601	INFI-NET Communications Modules
I-E96-620	INPCI01 Plant Loop to Computer Interface
I-E96-621	INPCI02 Plant Loop to Computer Interface
I-E96-624	INPPR01 Plant Loop to Plant Loop Interface

© Network 90 is a registered trademark of Eltag Bailey Process Automation.

NOMENCLATURE

Table 1-3 is a list of related hardware. Hardware and cables with part numbers are listed in Table 1-4.

Table 1-3. Nomenclature

Nomenclature	Hardware
HCBL01	RS-232-C Cable
IISAC01	Analog control station
IMMFC03 IMMFC04 IMMFC05	Multi-function controller module
INICT01	INFI-NET to computer transfer module
NPCT01	Plant Loop to computer transfer module
INPPT01	Plant Loop to plant loop transfer module
NDCS03	Digital control station
NICS01	Control/station termination module
NIDS01	Digital station termination module
NKTM01	Termination module cable (ribbon)
NKTU02	Termination module cable (PVC)
NKTU12	Termination module cable (non-PVC)
NTMU01	Termination mounting unit (rear mount)
NTMU02	Termination mounting unit (front mount)

SPECIFICATIONS

Refer to Table 1-4 for the specifications of the NIMF01 and NIMF02 termination modules.

Table 1-4. Specifications

Property	Characteristic/Value
Power Requirements	+24 VDC 160 mA current consumption, maximum (the LED consumes 10 mA)
Communication	2 RS-232-C ports 1 serial link for stations
Cable Insulation Specifications PVC (UL Rating CL2) Non-PVC (UL Rating PLTC)	80°C (176°F) at 300 V 90°C (194°F) at 300 V

Table 1-4. Specifications (continued)

Property	Characteristic/Value
Mounting	Slides into a single slot in the termination mounting unit.
Electromagnetic Radio Frequency Interference	Values are not available at this time. Keep cabinet doors closed. Do not use communication equipment any closer than 2 meters from the cabinet.
Cooling Requirements	No cooling necessary when used in Bailey Controls cabinets and operated within stated environmental limits.
Operating Temperature	0°C to 70°C (32°F to 158°F)
Relative Humidity	5% to 90% up to 55°C (131°F) (noncondensing)
	5% to 90% up to 70°C (158°F) (noncondensing)
Altitude	Sea level to 3 km (1.86 mi)
Air Quality	Bailey Controls equipment should be operated and stored in a noncorrosive environment.
Certification	All termination modules are CSA certified as process control equipment for use in an ordinary (nonhazardous) location.

SPECIFICATIONS ARE SUBJECT TO CHANGE WITHOUT NOTICE.

SECTION 2 - INSTALLATION

INTRODUCTION

This section lists the steps to properly install the NIMF01 and NIMF02 Multi-Function Controller Termination Modules. The installation procedure includes physical installation, dipshunt configuration, cable connection, power wiring and handling. To properly install the IMF termination module do the steps in this section in the order they appear.

SPECIAL HANDLING

Observe these steps when handling electronic circuitry:

NOTE: Always use Bailey Controls field static kit (part number 1948385A1 - consisting of two wrist straps, ground cord assembly, alligator clip, and static dissipative work surface) when working with the modules. The kit grounds a technician and the static dissipative work surface to the same ground point to prevent damage to the modules by electrostatic discharge.

1. **Use Static Shielding Bag.** Keep the modules in the static shielding bag until you are ready to install them in the system. Save the bag for future use.
2. **Ground Bag Before Opening.** Before opening a bag containing an assembly with CMOS devices, touch it to the equipment housing or a ground to equalize charges.
3. **Avoid Touching Circuitry.** Handle assemblies by the edges; avoid touching the circuitry.
4. **Avoid Partial Connection of CMOS Device.** Verify that all devices connected to the modules are properly grounded before using them.
5. **Ground Test Equipment.**
6. **Use an Antistatic Field Service Vacuum.** Remove dust from the module if necessary.
7. **Use a Grounded Wrist Strap.** Connect the wrist strap to the appropriate grounding plug on the power entry panel. The grounding plug on the power entry panel is connected to the earth grounding electrode system through the AC safety ground.
8. **Do Not Use Lead Pencils to Set Dipswitches.** To avoid contamination of dipswitch contacts that can result in unnecessary circuit board malfunction, do not use a lead pencil to set a dipswitch.

UNPACKING AND INSPECTION

1. Examine the hardware immediately for shipping damage.
2. Notify the nearest Bailey Controls sales office of any such damage.
3. File a claim for any damage with the transportation company that handled the shipment.
4. Use the original packing material and container to store the hardware.
5. Store the hardware in an environment of good air quality, free from temperature and moisture extremes.

SETUP/PHYSICAL INSTALLATION

This section explains how to configure and install the IMF termination module. Configure the dipshunts before installing the IMF termination module. There are four dipshunts, two for each RS-232-C port. These dipshunts define the active handshake lines. Each port can be configured as a DTE or DCE device. Only port two can terminate a diagnostic terminal. The IMF termination modules can interface to:

- Device.

Printer.
Sequence of events recorder.
IBM[®] PC.
COMPAQ[®] and compatible computers.
- Terminals.

VT1XX.
ADM3.
VISUAL 50.
WYSE (WY50).
TELEVIDEO.
FALCO.

NOTES:

1. The IMMFC04 and IMMFC05 Multi-Function Controller Modules use the IMF termination module for its link to stations and for connecting a redundant MFC module. They do not have serial communication capabilities. Therefore, no dipshunts are required when terminating the IMMFC04 or IMMFC05 modules.
2. Only the IMMFC03 Multi-Function Controller module drives the IMF termination modules LED. The LED will not light when the IMF termination module is used with an IMMFC04 or IMMFC05 Multi-Function Controller module.

[®] IBM is a registered trademark of International Business Machines Corporation.

[®] COMPAQ is a registered trademark of COMPAQ Corporation

Dipshunt Configuration for DTE or DCE

Configure dipshunts XU1 or XU2 and XU3 or XU4 so that their respective ports operate as DTE or DCE. Port two can be used to interface a diagnostic terminal. Figure 2-1 shows the connector assignments and dipshunt location on the NIMF01 termination module. Figure 2-2 shows the connector assignments and dipshunt location on the NIMF02 termination module. Install the appropriately cut dipshunts using Figures 2-3 and 2-4.

NOTES:

1. The IMF termination module dipshunt settings shown in Figures 2-3, 2-4, and 2-5 apply to the MFC and INICT01 modules. Figure 2-6 applies only to the INICT01 module. Figures 2-7, 2-8, and 2-9 show the dipshunt settings required when using the IMF termination module to terminate an INPPT01 module.
2. If an isolating modem is used, and pins one (protective ground) and seven (signal common ground) of the modem connector are tied together, dipshunt strap three of XU2 and XU4 must be cut. Doing this maintains the isolation of DC common and safety ground within the INFI 90/Network 90 system.

Dipshunt Configuration for a Mainframe Computer

The INICT01 and INPCT01 modules can interface to a mainframe computer (MODCOMP or VAX). To set up the IMF termination module to terminate a mainframe, refer to Figure 2-6

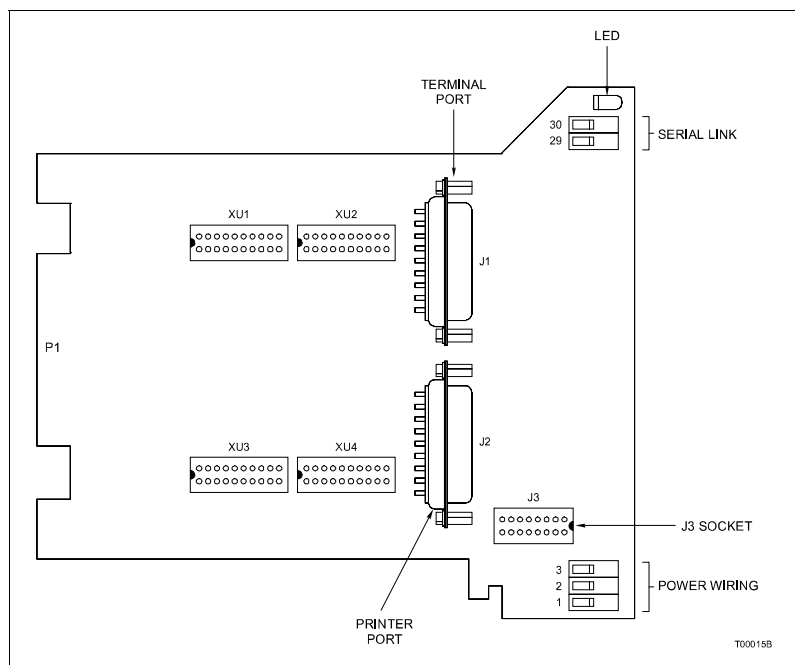

Figure 2-1. NIMF01 Connector Assignments and Dipshunt Locations

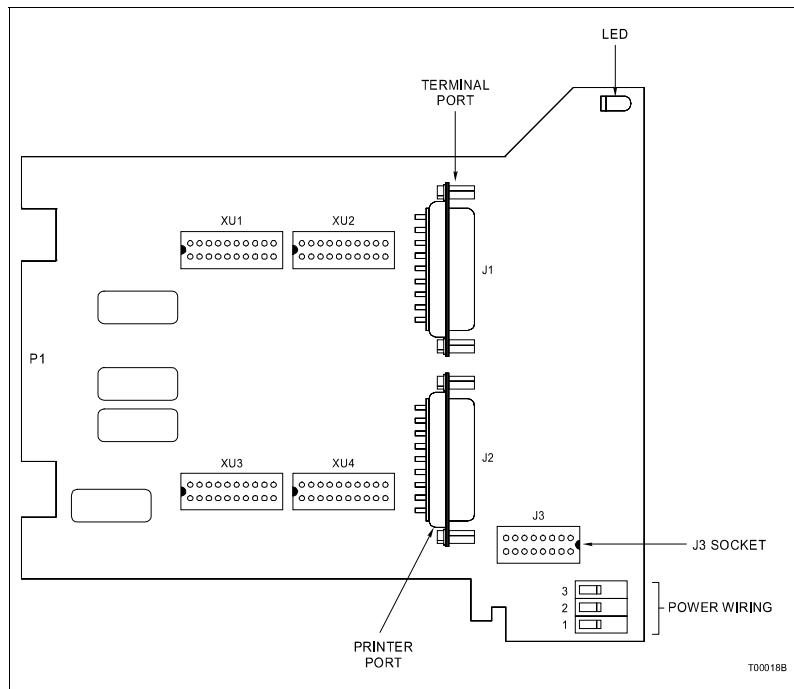

Figure 2-2. NIMF02 Connector Assignments and Dipshunt Locations

and install the appropriate set of dipshunts (XU1 or XU2 and XU3 or XU4) as shown.

Dipshunt Configuration for the INPPT01 Module

When the IMF termination module is used to terminate an INPPT01 module, use the dipshunt settings shown in Figures 2-7 through 2-10. To install the dipshunts:

1. If connecting a local Plant Loop (DTE) to a remote Plant Loop (DTE) through a modem or microwave link (DCE), use the dipshunt settings shown in Figure 2-7. Set the IMF module for both the local and remote PPT to the dipshunt settings shown.
2. If connecting a local Plant Loop (DTE) directly to a remote Plant Loop (DTE) via a cable (DCE), use the dipshunt settings shown in Figure 2-8 (local) and Figure 2-9 (remote).
3. To connect a diagnostic terminal to the INPPT01 module, use port two on the IMF module and the dipshunt settings shown in Figure 2-10.

Sequence of Events Recorder

The IMF termination module interfaces with the Rochester 3800, Rochester ISM and ESA Controls SER-740 Sequence of

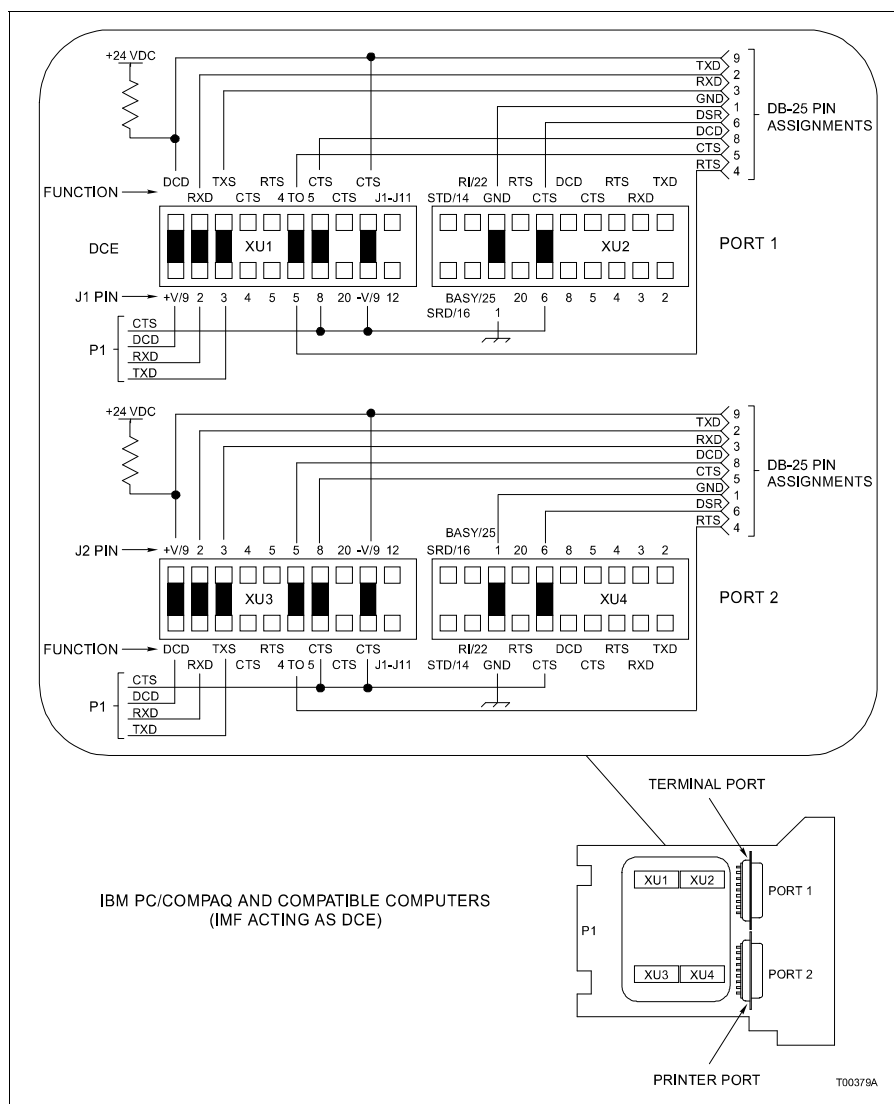

Figure 2-3. Dipshunt Configuration for Direct Connection to Host Computer (MFC and ICT modules)

Events recorders. Refer to Figures 2-11 and 2-12 for dipshunt configurations.

Cabling Connections

Figure 2-13 shows the cable connections from the NIMF01 termination module to the primary module. Figure 2-14 shows the cabling connection for redundancy using the NIMF02 termination module. Table 2-1 lists the IMF termination module cable applications.

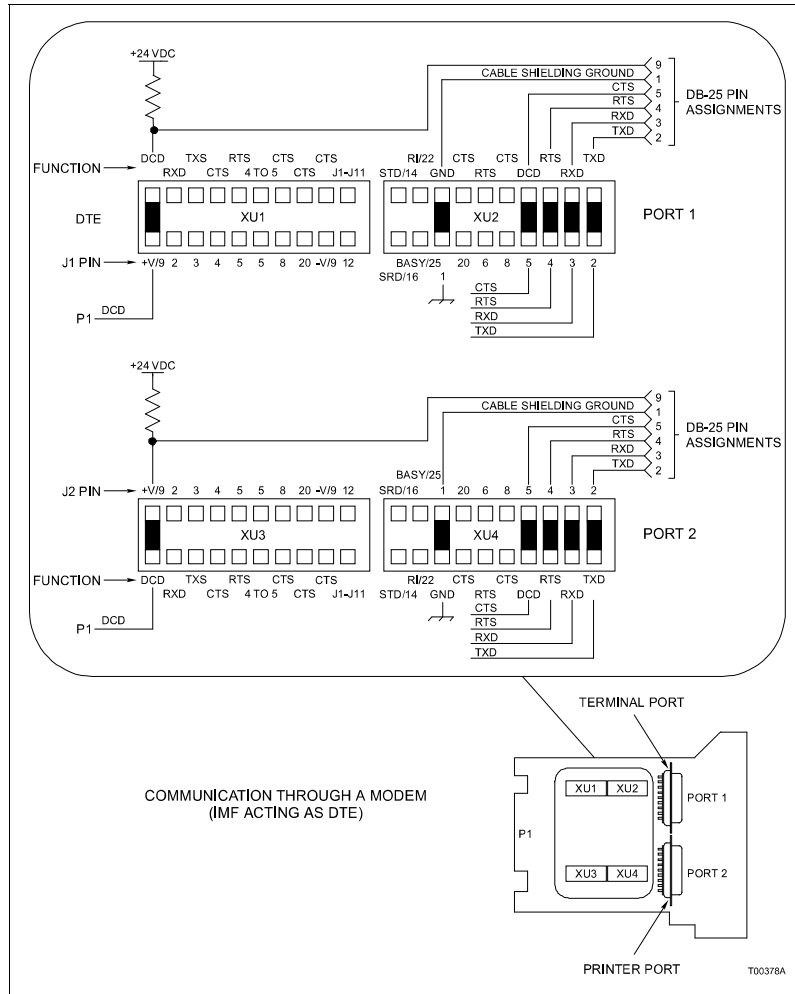

Figure 2-4. Dipshunt Configuration for Direct Connection to Modem (MFC and ICT modules)

Cable Installation

CAUTION

Remove a module from its assigned slot before installing or removing a cable assigned to that slot. Failure to do so could result in damage to the module.

ATTENTION

Avant de retirer ou de brancher un câble, retirez le module logé dans la coulisse correspondante. Autrement, le module risque d'être endommagé.

Figures 2-13 and 2-14 show the cable connections between the modules, termination modules, and output devices. The cable from the IMF termination module to the module can be either the NKTU02 or NKTU12 Termination Module Cable (round cable) or the NKTM01 Termination Module Cable (ribbon cable).

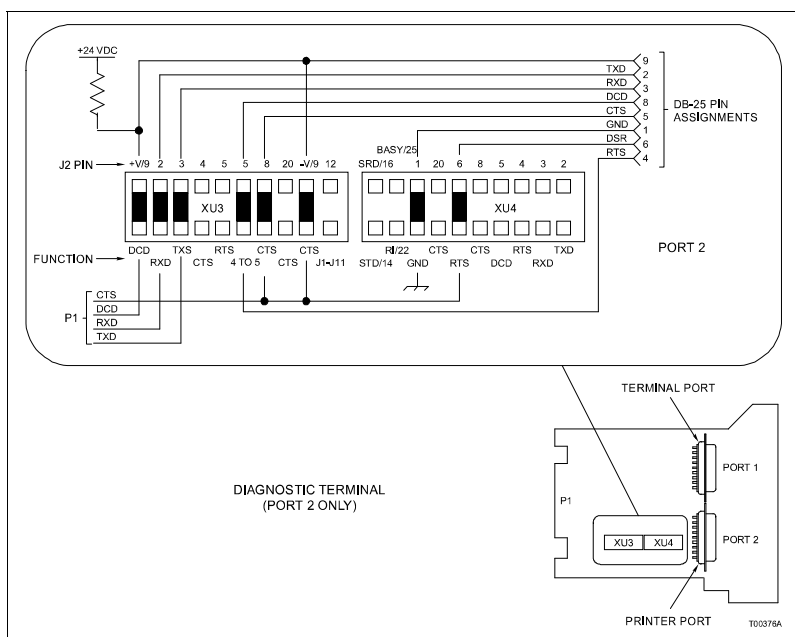

Figure 2-5. Dipshunt Configuration for Diagnostic Terminal (MFC and ICT modules)

NKTM01

This cable connects the NIMF01 termination module to the primary module and the NIMF02 termination module to the redundant module. The NKTM01 cable is a flat ribbon cable (30 meters or 100 feet maximum). Do not bundle the ribbon cable with other wiring. Bundling the cable can cause cross talk in the ribbon cable. To install the cable:

NOTE: If the module is installed, pull it several inches from the backplane before installing the cable.

1. Insert one end of the cable into the module mounting unit backplane slot assigned to the module. The cable should latch securely in place. Card edge connector P3 of the module connects to this end of the cable.
2. Insert the other end of the cable into the termination mounting unit (TMU) backplane slot assigned to the IMF termination module. The cable should latch securely in place. Card edge connector P1 of the IMF termination module connects to this end of the cable.

NKTU02 OR NKTU12

This cable connects the NIMF01 termination module to the primary module and the NIMF02 termination module to the redundant module. The NKTU02 or NKTU12 cable is a round

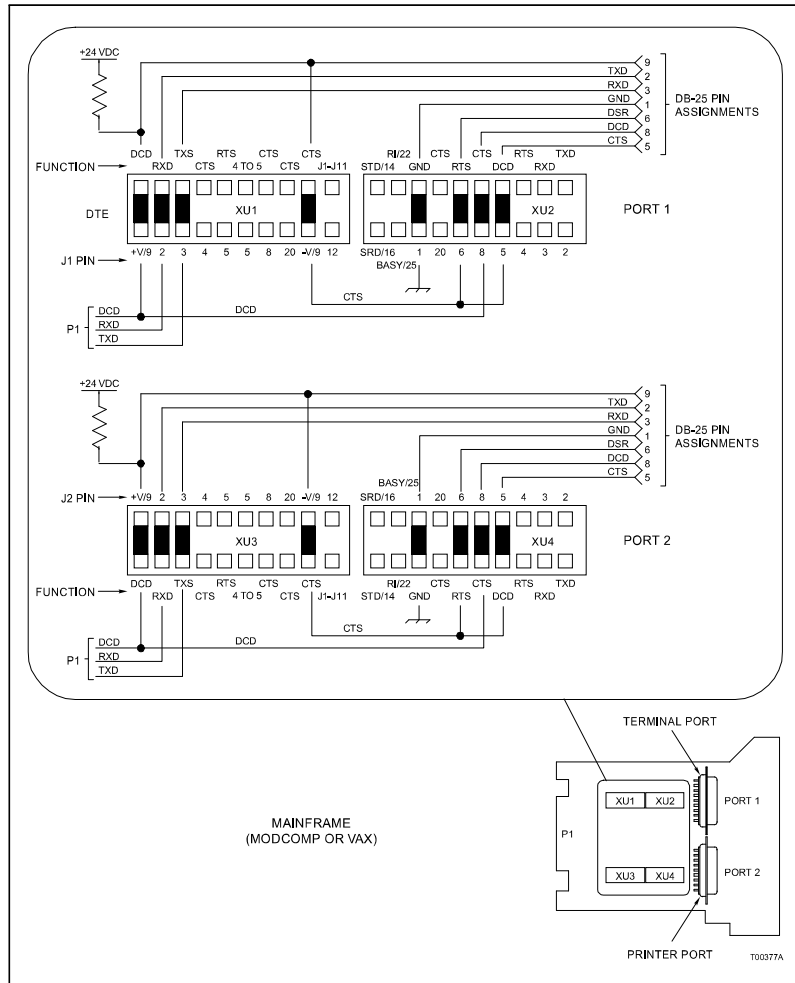

Figure 2-6. Dipshunt Configuration for Direct Connection to Mainframe Computer (ICT module)

cable (61 meters or 200 feet maximum). The cable is shielded. To install the cable:

NOTE: If the module is installed, pull it several inches from the backplane before installing the cable.

1. Insert the J2 end of the cable into the module mounting unit backplane slot assigned to the module. The cable should latch securely in place. Card edge connector P3 of the module connects to this end of the cable.
2. Connect the shield wire from the J2 end to the shield bus bar.
3. Insert the J1 end of the cable into the termination mounting unit (TMU) backplane slot assigned to the IMF termination module. The cable should latch securely in place. Card edge

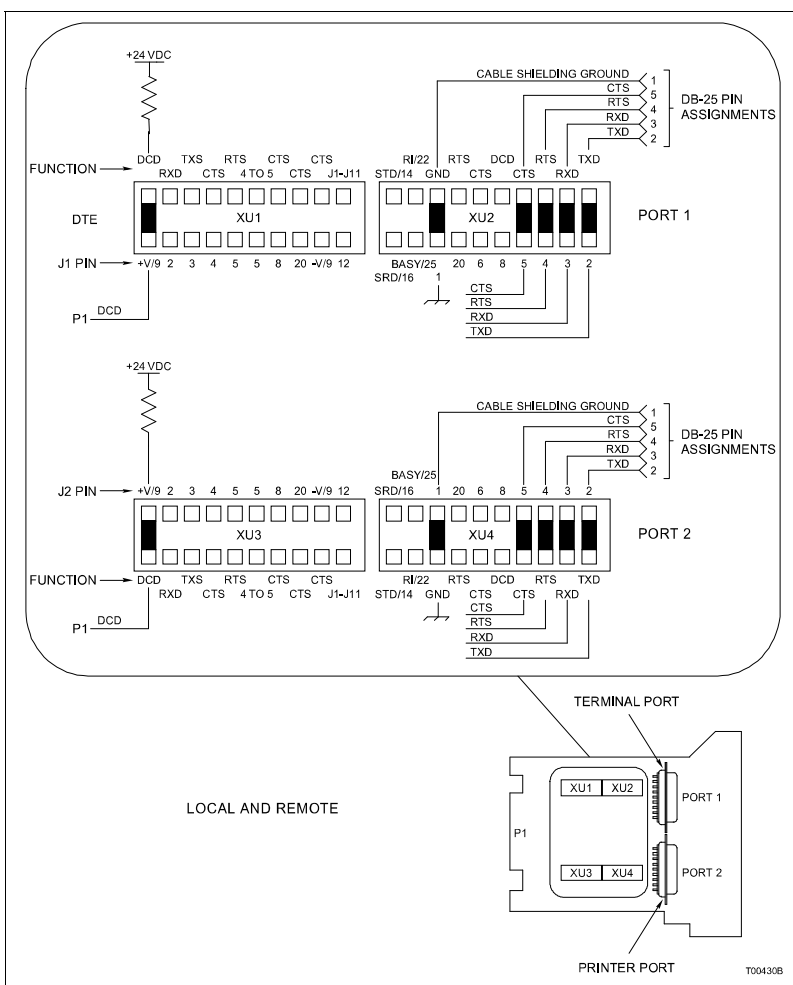

Figure 2-7. Dipshunt Configuration for PPT Module Acting as DTE (requires modem or other DCE)

connector P1 of the IMF module connects to this end of the cable.

4. Install a cable retaining bracket to the rear of the TMU unit.

RS-232-C COMMUNICATION CABLE

The RS-232-C communication cable connects the IMF module to a computer, terminal, printer or modem (see Figure 2-14). Table 2-1 lists the requirements of the RS-232-C cable, its application, connector assignments and length restrictions. Figure 2-15 shows the DB-25 connector pin assignments. To install the RS-232-C cable:

1. Turn off power to host computer or terminal.

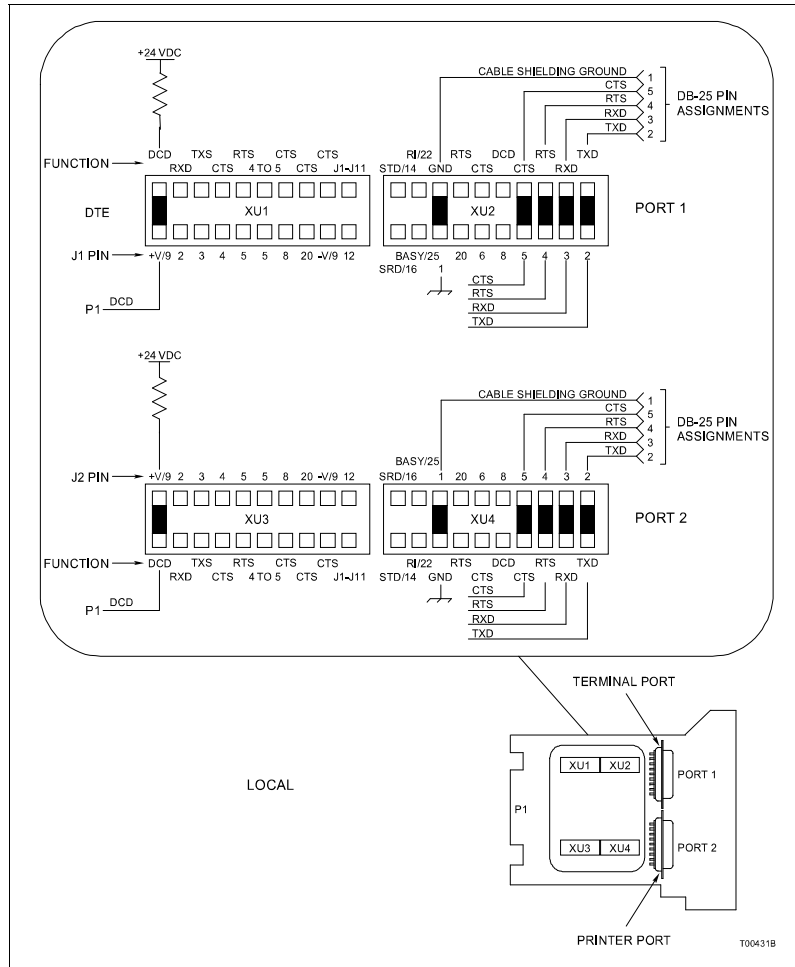

Figure 2-8. Dipshunt Configuration for Direct Connection of Local PPT Module Acting as DTE

2. Install the RS-232-C cable to the DB-25 connector on the IMF marked J1 for port one. Connect the other end of the RS-232-C cable to the external device.
3. Install the RS-232-C cable to the DB-25 connector on the IMF marked J2 for port two. Connect the other end of the RS-232-C cable to the external device.

RIBBON CABLE 6634408A2

This cable connects the NIMF01 and NIMF02 termination modules for redundant module configuration. To install the cable:

1. Insert one end of the cable into the J3 socket of the NIMF01 module.

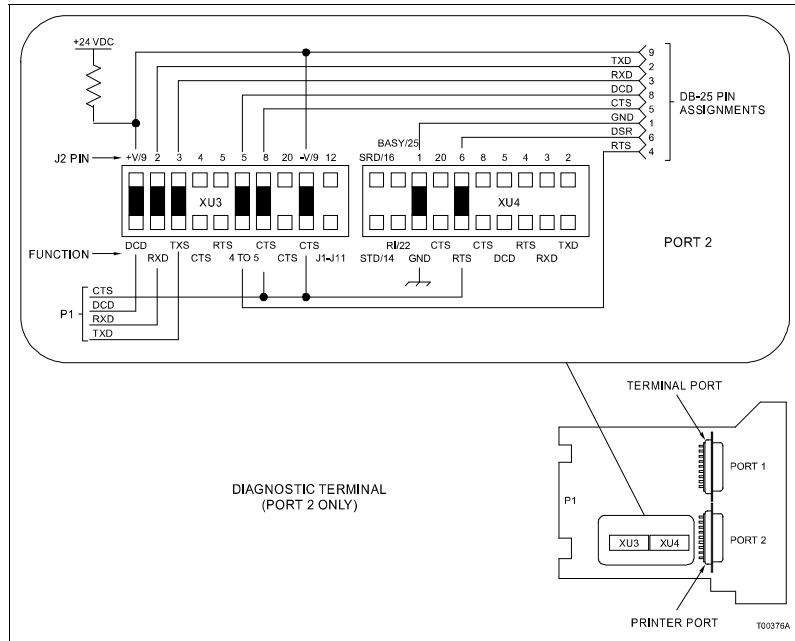

Figure 2-10. Dipshunt Configuration for Diagnostic Terminal (PPT module)

Terminal Wiring

CAUTION

It is strongly recommended that all power (cabinet, I/O, etc.) be turned off before doing any termination module wiring. Failure to do so could result in equipment damage. Do not apply power until all connections are verified.

ATTENTION

Il est fortement recommand, que toutes les alimentations (armoire, E/S, etc.) soient coupées avant d'effectuer quelque raccord que ce soit sur un carte de raccordement. Un manquement à ces instructions pourrait causer des dommages à l'équipement. Ne pas rebrancher les alimentations avant d'avoir vérifié tous les raccordements.

Serial link and power wiring must be connected to the NIMF01 terminal strip. See Figure 2-16 for NIMF01 termination module terminal strip assignments. The NIMF02 only has power wiring terminals. Figure 2-17 shows the NIMF02 terminal strip assignments.

NOTE: Proper polarity of all signals must be maintained.

To connect serial link and power wiring:

1. Remove the front cover.

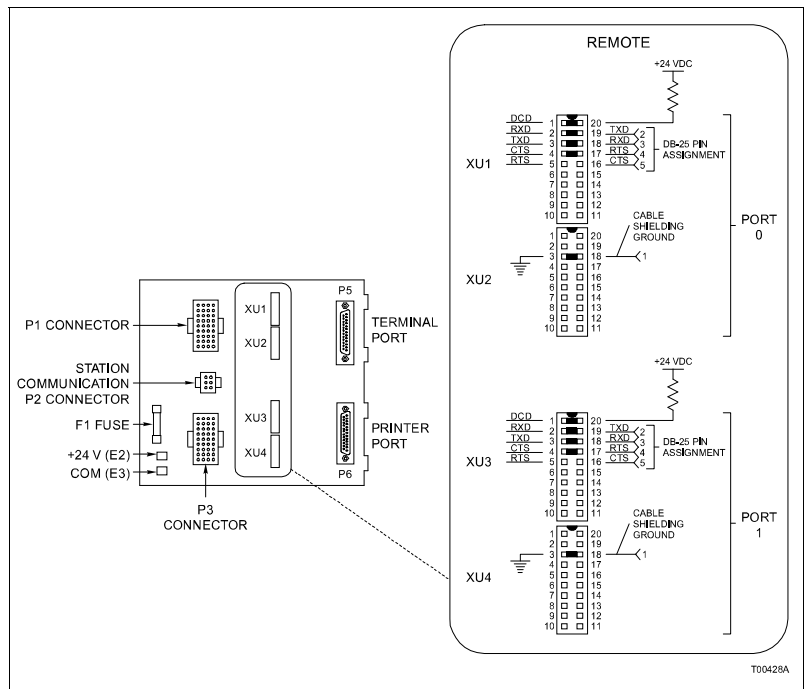

Figure 2-11. Dipshunt Configuration for Rochester 3800 and ESA Control SER-740

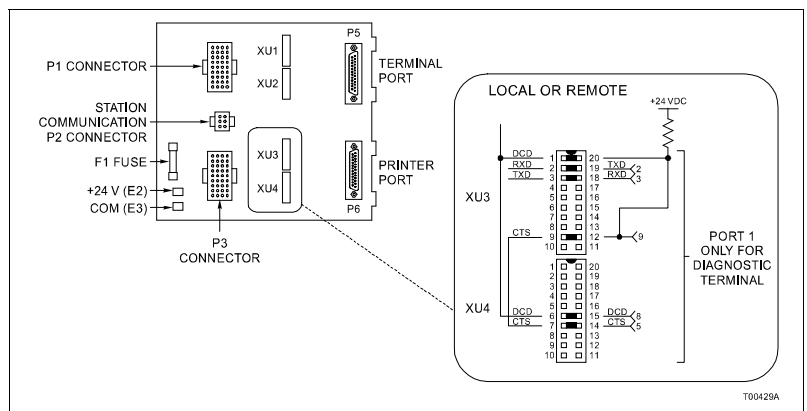

Figure 2-12. Dipshunt Configuration for Rochester ISM

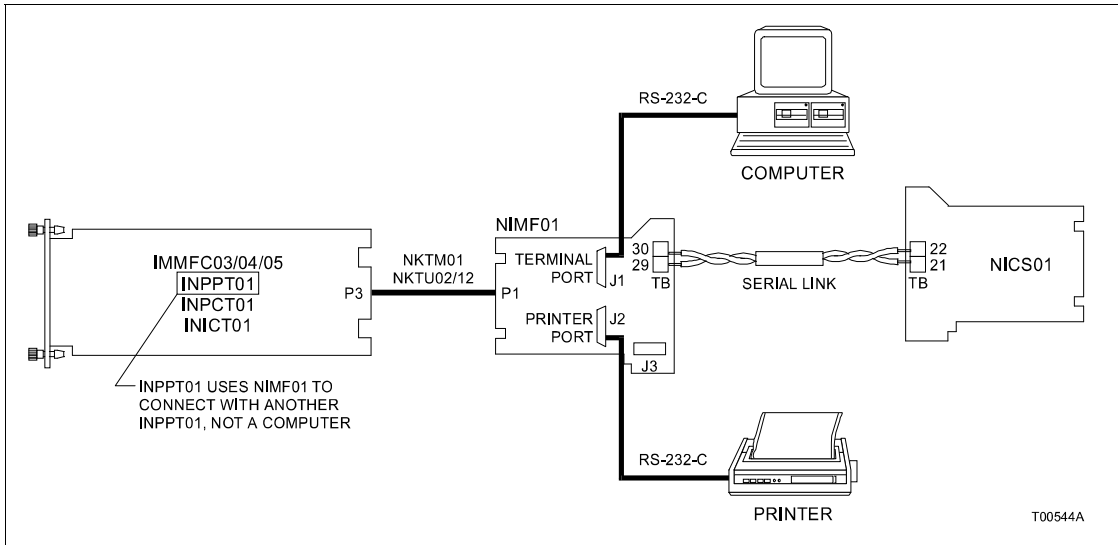

Figure 2-13. NIMF01 Cable Connections

Table 2-1. IMF Cable Applications, Cable Connections and Length Requirements

Cable	Connections				Maximum Length	
	From		To			
HCBL01	DCE or DTE device	DB-25	NIMP01	J1 or J2	15	50 ¹
NKTU01	NIMF01	P1	Primary module	P3	30	100
	NIMF02	P1	Redundant module	P3	30	100
NKTU02 or NKTU12	NIMF01	P1	Primary module	P3	61	200
	NIMF02	P1	Redundant module	P3	61	200
R2041-1976	NIMF01	TB29 and TB30	NICS01	TB21 and TB22	457	1500
6645508A2	NIMF01	J3	NIMF02	J3	30	100

NOTE:

1. The specified maximum length only applies to the HCBL01 cable. The performance of INFI 90 modules do not place a restriction on the maximum length of the RS-232-C cable. Follow industry-wide accepted RS-232-C practices and rules when selecting a suitable RS-232-C cable for your system.

2. Ensure the IMF module is pulled out far enough to gain access to the terminal strip.
3. Feed the serial link wiring into the terminal strip area and connect them to the appropriate terminals.

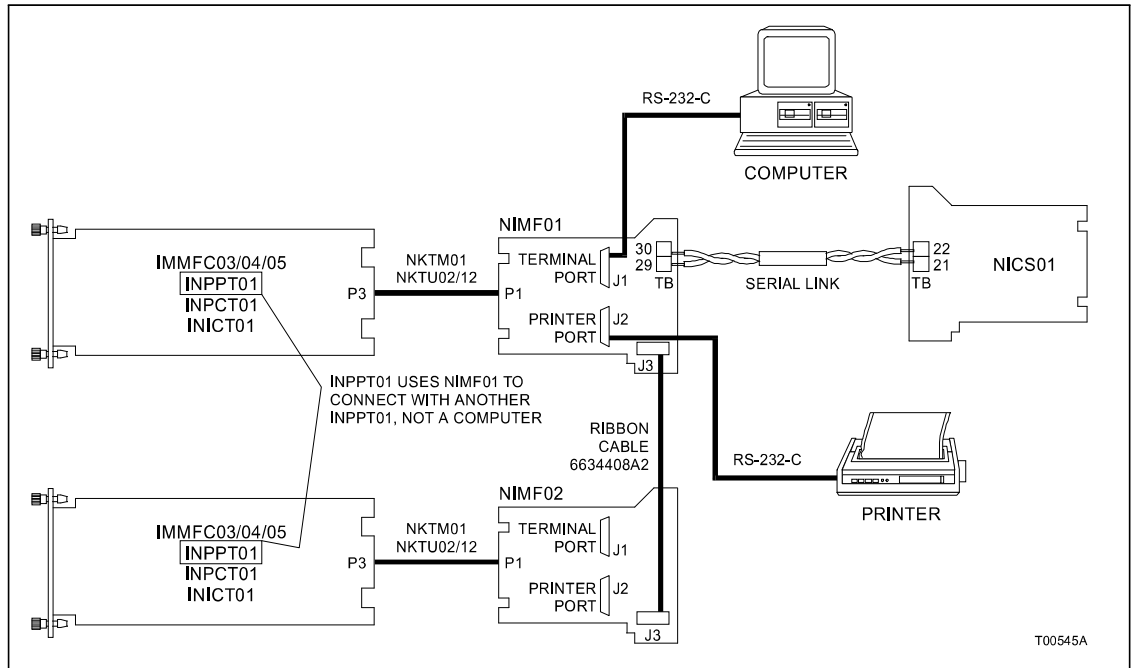

Figure 2-14. NIMF02 Cable Connections

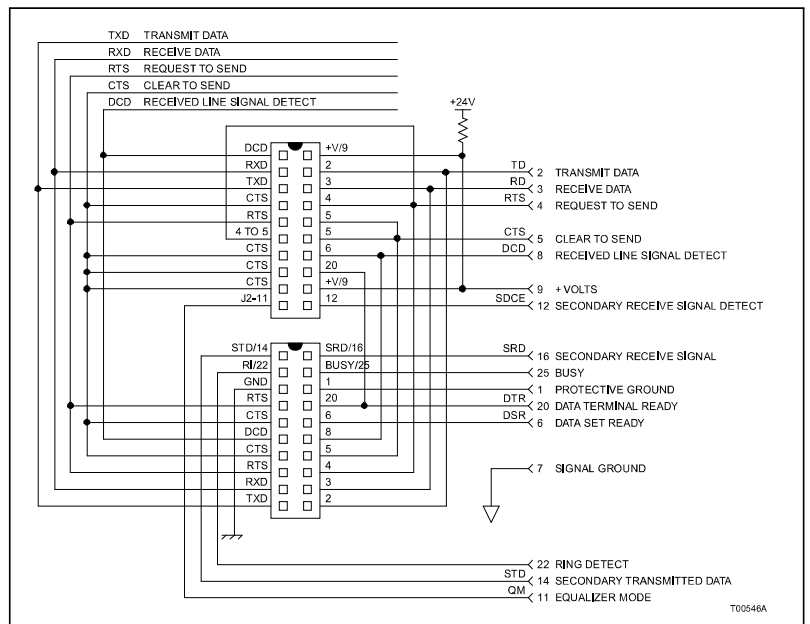

Figure 2-15. DB-25 Pin Assignments and RS-232-C Signals

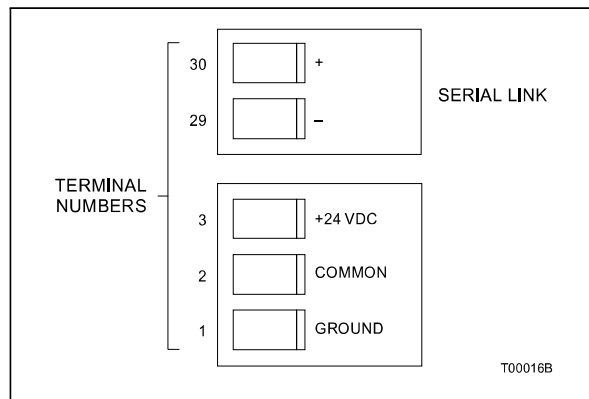

Figure 2-16. NIMF01 Terminal Assignments

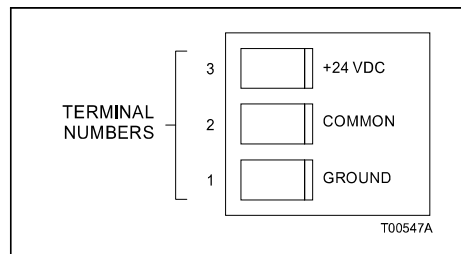

Figure 2-17. NIMF02 Terminal Assignments

4. Connect an 18 AWG wire from the +24 VDC bus of the termination mounting unit to the +24 VDC terminal of the IMF module.
5. Connect an 18 AWG wire from the common bus of the termination mounting unit to the common terminal of the IMF module.
6. Connect an 18 AWG wire from the chassis ground terminal of the IMF module to the cabinet chassis ground bolt.
7. Insert the module until it locks securely into place.
8. Replace (snap on) the front cover.

The IMF termination module is ready for operation if:

1. The fuses are installed.
2. The cable is installed and verified.
3. All field wiring is complete.
4. Power is connected and applied to the IMF module.

SECTION 3 - MAINTENANCE

INTRODUCTION

The multi-function controller termination modules (IMF) require limited maintenance. This section contains a maintenance schedule.

MAINTENANCE SCHEDULE

Execute the tasks in Table 3-1 at the specified intervals.

Table 3-1. Maintenance Schedule

Task	Interval
Clean and tighten all power and field wiring connections.	Every 6 months or during plant shutdown, whichever occurs first.
Use a static safe vacuum cleaner to remove dust from: Termination modules. Termination mounting unit.	

SECTION 4 - REPAIR/REPLACEMENT PROCEDURES

INTRODUCTION

This section explains the replacement procedures for the multi-function controller termination modules (IMF).

MODULE REPLACEMENT PROCEDURES

If an IMF termination module is faulty, replace it with a new one. Table 4-1 lists the recommended spare parts.

NOTES:

1. When replacing a termination module, verify that the dipshunt settings on the replacement termination module are the same as the failed termination module.
2. Turn off power to the computer, modem or diagnostic terminal before pulling the termination module out of its slot to remove the RS-232-C cables from the IMF termination module.

Table 4-1. Recommended Spare Parts List

Description	Part Number
Ribbon cable	6634408A2

CAUTION

It is strongly recommended that all power (cabinet, I/O, etc.) be turned off before doing any termination module wiring. Failure to do so could result in equipment damage. Do not apply power until all connections are verified.

ATTENTION

Il est fortement recommandé, que toutes les alimentations (armoire, E/S, etc.) soient coupées avant d'effectuer quelque raccord que ce soit sur un carte de raccordement. Un manquement à ces instructions pourrait causer des dommages à l'équipement. Ne pas rebrancher les alimentations avant d'avoir vérifié tous les raccords.

1. Pull the termination module out of the TMU so that the RS-232-C and power cables are accessible.
2. Turn off power to the cabinet and disconnect the +24 VDC, common and chassis ground wiring from TB1, TB2 and TB3 of the termination module. Mark the cables according to their terminal assignments as you remove them.
3. If there is a serial link to a station termination module, disconnect the serial link from TB29 and TB30. Mark the cables according to their terminal assignments as you remove them. The NIMF02 does not have a serial link connection.

4. If there is a redundant termination module (an NIMF01 and NIMF02) disconnect the ribbon cable from the J3 socket on the faulty termination module.
5. Remove the RS-232-C cables from the DB-25 connectors on the faulty IMF termination module. Mark the cables according to their connector assignments as you remove them.
6. When all cables are removed from the termination module, pull it out of the TMU unit.
7. Align the replacement termination module with the guide rails of its assigned slot in the TMU unit.
8. Partially insert the replacement termination module and connect the RS-232-C cables, power wiring, serial link and ribbon cable.
9. After all cables and wires have been replaced, slide the termination module into the TMU unit until its card edge seats in the card edge connector of the termination module cable on the backplane of the TMU unit.
10. Return power to the computer, modem or diagnostic terminal. Return power to the cabinet containing the IMF termination module.