

GE Fanuc IC694MDL940

<http://www.pdfsupply.com/automation/ge-fanuc/rx3i-pacsystem/IC694MDL940>

Rx3i PacSystem

Output module, relay 2 amp 16 point, non isolated. IC694M IC694MD
IC694MDL

919-535-3180
sales@pdfsupply.com

Output Module, Relay Output, N.O., 2 Amp, 16 Point: IC694MDL940

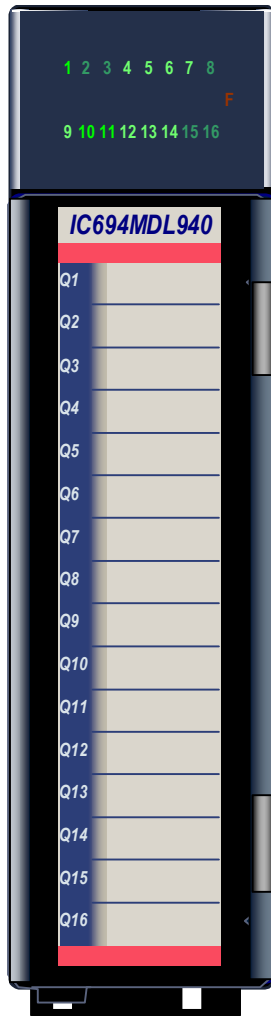

The **2 Amp Relay Output** module, IC694MDL940, provides 16 normally-open relay circuits for controlling output loads. The output switching capacity of each output is 2 Amps. The output points are in four groups of four points each. Each group has a common power output terminal. The relay outputs can control a wide range of load devices, such as: motor starters, solenoids, and indicators. Power for the internal relay circuits is provided by the +24 volt DC bus on the backplane. The user must supply the AC or DC power to operate field devices.

Individual numbered LEDs show the ON/OFF status of each output point. There are no fuses on this module. The red bands on the label show that MDL940 is a high-voltage module.

This module can be installed in any I/O slot in an RX3i system.

Specifications: MDL940

Rated Voltage	24 volts DC, 120/240 volts AC (nominal - see the following table for exceptions)
Operating Voltage	5 to 30 volts DC 5 to 250 volts AC, 50/60 Hz
Outputs per Module	16 (four groups of four outputs each)
Isolation:	
Field to Backplane and to Frame Ground	250 VAC continuous; 1500 VAC for 1 minute
Point to Point	250 VAC continuous; 1500 VAC for 1 minute
Maximum Load	2 Amps pilot duty maximum per output 4 Amps maximum per common
Minimum Load	10mA
Maximum Inrush	5 Amps
On Response Time	15ms maximum*
Off Response Time	15ms maximum*
Power Consumption, all outputs on	7mA from 5 volt bus on backplane 135mA from relay 24V bus on backplane

Refer to Appendix A for product standards and general specifications.

* When this module is used with DC power supply IC695PSD040 or PSD140, special precautions should be taken because dropouts in the source voltage will be seen by this module and may cause relay dropouts.

Load Current Limitations: MDL940

Operating Voltage	Maximum Current for Load Type		Typical Contact Life (Number of Operations)
	Resistive	Lamp or Solenoid *	
24 to 120 VAC	2 Amps	1 Amp	300,000
24 to 120 VAC	1 Amp	0.5 Amp	500,000
24 to 120 VAC	0.1 Amp	0.05 Amp	1,000,000
240 VAC	2 Amps	1 Amp	150,000
240 VAC	1 Amp	0.5 Amp	200,000
240 VAC	0.1 Amp	0.05 Amp	500,000
24 VDC	–	2 Amps	100,000
24 VDC	2 Amps	1 Amp	300,000
24 VDC	1 Amp	0.5 Amp	500,000
24 VDC	0.1 Amp	0.05 Amp	1,000,000
125 VDC	0.2 Amp	0.1 Amp	300,000

* Assumes a 7 ms time constant

Relay contact life, when switching inductive loads, will approach resistive load contact life if suppression circuits are used. The following figures are examples of typical suppression circuits for AC and DC loads. The 1A, 200V diode shown in the DC load suppression circuit is an industry standard 1N4935. The resistor and capacitor shown for AC load suppression are standard components.

Load Suppression Examples for Output Module IC694MDL940

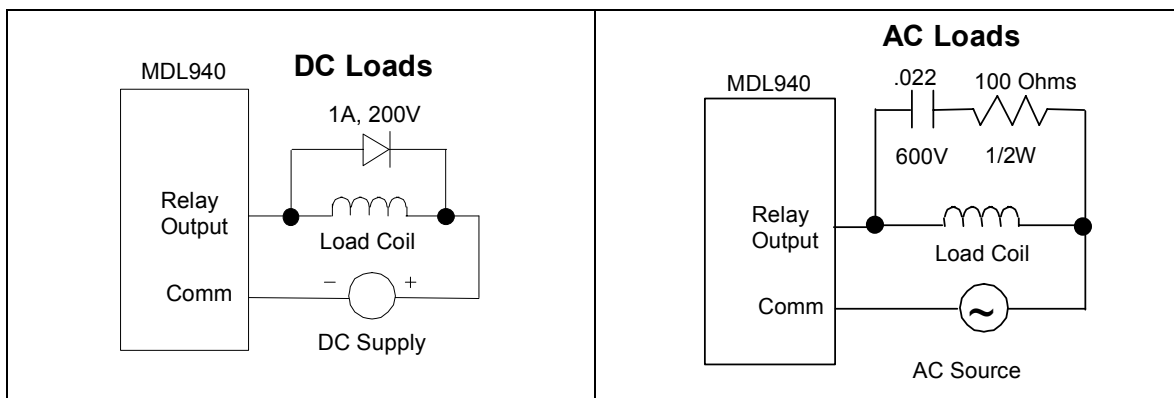

Field Wiring: MDL940

Terminal	Connection
1	Outputs 1 – 4 common (return)
2	Output 1
3	Output 2
4	Output 3
5	Output 4
6	Outputs 5 -8 common (return)
7	Output 5
8	Output 6
9	Output 7
10	Output 8
11	Outputs 9 - 12 common (return)
12	Output 9
13	Output 10
14	Output 11
15	Output 12
16	Outputs 13 – 16 common (return)
17	Output 13
18	Output 14
19	Output 15
20	Output 16

