



Safety Manager Release 162



Hardware Reference

EP-SM.MAN.6284

Issue 2.1 | December 2023

- Original Instructions -

5 Chassis

5.2 CPCHAS-0001

Distribution of the various Control Processor modules in the Controller chassis

Redundant Controller								
Non-Redundant Controller								
C P U 1	C O M 1 . 1	C O M 1 . 2	P S U 1	B K M	C P U 2	C O M 2 . 1	C.O.M.2.2	P S U 2
Legend:								
Item	Description						See	
CPU1	the processor module of the first Control Processor							
	QPP-0002 Quad Processor Pack						QPP-0002	
COM1.1	the first communication module of the first Control Processor							
	USI-0002 Universal Safety Interface, or						FX-USI-0002	
	BLIND-COM Dummy Communication Module						BLIND-COM	
COM1.2	the second communication module of the first Control Processor							
	USI-0002 Universal Safety Interface, or						FX-USI-0002	
	BLIND-COM Dummy Communication Module						BLIND-COM	
PSU1	the power supply module of the first Control Processor							
	PSU-240516 Power Supply Unit 24/5 V DC, 16A						PSU-240516	
BKM	the battery and key switch module of (both) Control Processor(s)							
	BKM-0001 Battery and Key switch Module						BKM-0001	
CPU2	the processor module of the first Control Processor							
	QPP-0002 Quad Processor Pack						QPP-0002	

7 Control Processor modules

This chapter describes the following Control Processor modules:

Module	
USI-QPP-0002	Quad Processor Pack
BLIND-COM	Dummy communication module
BKM-0001	Battery and Key switch Module
PSU-240516	Power Supply Unit 24/5 V DC, 16 A

7.1 General info about Control Processor modules

Each Safety Manager Control Processor module is located in a pre-determined slot in the Controller chassis (see section CPCHAS-0002). Connectors and earth/keying pins in the backplane ensure they can only be placed in the slot reserved for that type of Control Processor module (see the below figure).

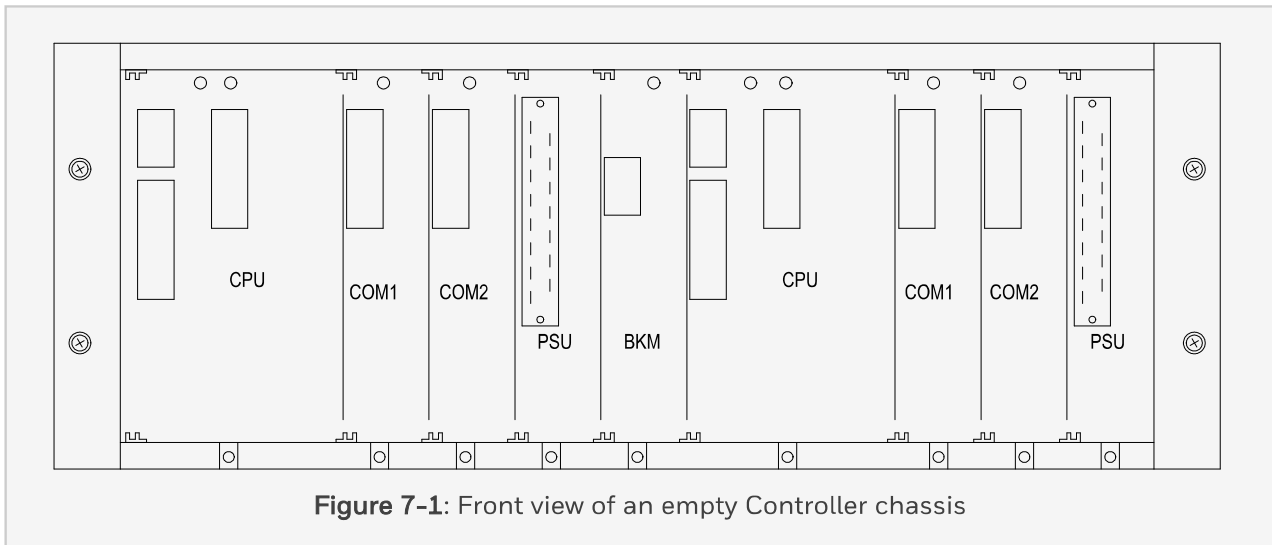

All connections and communication from and to Control Processor modules run via the Controller backplane (see section Controller backplane CPB-0001).

7 Control Processor modules

7.5 BKM-0001

7.5 BKM-0001

7.5.1 Battery and Key switch Module

The Battery and Key switch Module (BKM-0001) is located in the Controller chassis (see section CPCHAS-0001 or CPCHAS-0002 or CPCHAS-0003).

There is only one BKM-0001, even in a redundant Controller chassis.

The BKM-0001 contains the following items:

- Two batteries (one for each Control Processor)
- Force Enable key switch
- Reset key switch

The below figure shows the front view of the BKM-0001 module.



Figure 7-9: The front view of the BKM-0001 module

The BKM-0001 module may be placed or removed in a running system. The application program will not be interrupted by these actions.

Note:

Version 1.0 modules have a darker blue front plate.

7 Control Processor modules

7.5 BKM-0001

Attention:

Removal of the BKM-0001 module should only be done with its Force Enable key switch in the 'OFF' position. Extraction of the BKM-0001 module will always remove all forces.

7.5.2 Batteries

The BKM-0001 module contains non-rechargeable (lithium) batteries that supply the back-up power to maintain the diagnostic messages, the real time clock on the QPP modules and FTE IP addresses, in case of a power outage.

As the batteries are not recharged, the used back-up time is accumulating. *The total back-up time of the lithium cells is approximately 3 months.*

If the system is switched off for a longer period (and during transport), the batteries can be switched off with the battery switch on the module.

It is recommended to replace the batteries every five years and after every substantial discharge period.

Replacing the batteries requires no special tools.

The side plate of the BKM-0001 module has an opening to enable battery replacement and battery-switch operation (see the below figure).

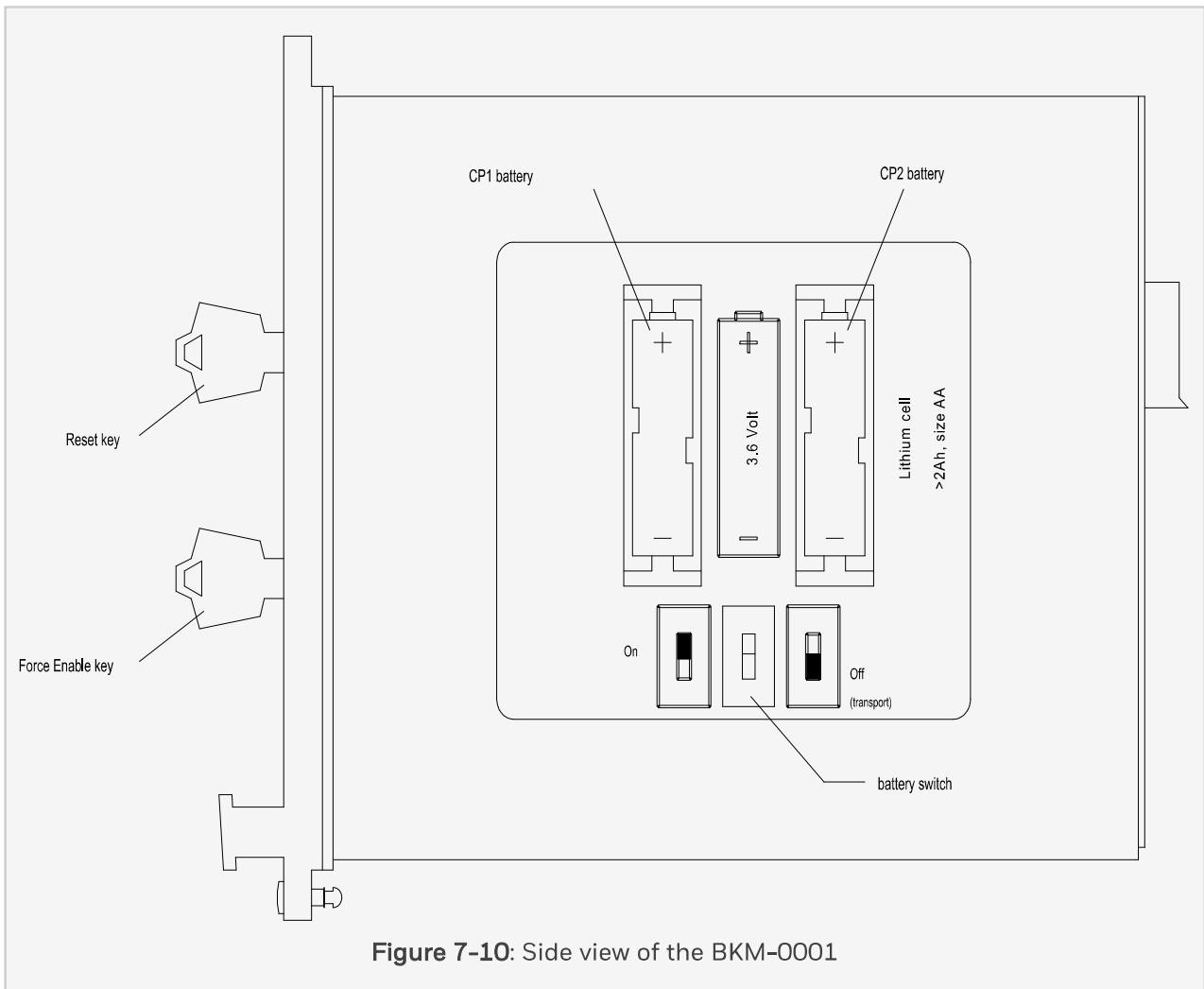

Figure 7-10: Side view of the BKM-0001

When the batteries are disconnected (battery switch in the OFF position) the status LED will stay red.

7.5.3 Reset key switch

The Reset key switch is used for emptying the diagnostics database and resetting (starting) the watchdog. Its default position is the OFF position, to which it will automatically return after setting it in the ON position. You can only remove the key in the OFF (vertical) position.

The key required for the Reset key switch is a different key than the one for the Force Enable key switch.

7 Control Processor modules

7.5 BKM-0001

Reset key switch state	Function
OFF	No action
ON	<ul style="list-style-type: none"> • The Watchdog signal is reset for both Control Processors. • The actual diagnostics will be moved to historical diagnostics database for both Control Processors.

7.5.4 Force Enable key switch

The Force Enable key switch is used for enabling or disabling software-controlled forcing of input and output signals. The key is removable in both positions.

The key required for the Force Enable key switch is a different key than the one for the Reset key switch.

Force Enable key switch state	Function
OFF	<p>Software-controlled forcing of input and output signals is not possible.</p> <p>All active forces are removed.</p>
ON	Software-controlled forcing of input and output signals is possible.

7.5.5 Status LED

The below table lists the possible LED status indications that are visible at the front side of the BKM-0001 module.

Table 1. LED indicators of the BKM-0001 module

LED	Status	Description
STATUS	off	The power to the module is down.
	Red	The battery switch is in OFF position. One (or both) battery voltage(s) are too low (or fuse is blown)
	Green	No battery error is detected.

7.5.6 Additional functionality

The diagnostics for the BKM-0001 include:

- BKM-0001 not placed.
- Battery voltage out of ranges (too high, too low and open circuit).

7 Control Processor modules

7.5 BKM-0001

7.5.7 Technical data

The BKM-0001 has the following specifications:

General ¹	Type numbers:	FS-BKM-0001
		FC-BKM-0001
	Operating temperature:	-5°C - +70°C (+23°F - +158°F)
	Storage temperature:	-40°C - +85°C (-40°F - +185°F)
	Relative humidity:	10-95% (non condensing)
	Approvals:	CE, TUV, UL, CSA, FM
Power	24 V supply voltage:	24 V DC -15%~+30%
	24 V supply current:	Max. 20 mA (out of each 24 V DC) typ. 7 mA (shared load on 24 V DC)
	5 VR supply voltage:	5 V DC ± 10%
	5 VR supply current:	Max. 10 mA
+24V_red	Output supply voltage:	14-31 V DC
	Output resistance:	Approx. 2 × 1.1 kΩ (parallel)
	Short circuit proof:	Continuous
Battery	Make ² :	SAFT
	Type ² :	LS14500CFG
	Material:	Lithium Thionyl Chloride
	Voltage:	Nominal 3.6 V
	Capacity:	> 2 Ah

7 Control Processor modules

7.5 BKM-0001

	Size:	AA
	Operating temperature:	-40°C - +85°C (-40°F-+185°F)
Physical	Dimensions:	176 x 35.2 x 224 mm (H x W x D) 6.93 x 1.4 x 8.81 in (H x W x D)
	Weight:	660 g

Note:

1. Version 1.0 modules have a darker blue front plate.
2. Use of specified make and type numbers is necessary to maintain UL approval.