

# **8 Node Multinode Module Service**

**MT13-420**

---

## INTRODUCTION Section 1

### 1.1 OVERVIEW

This manual provides detailed instructions for maintenance, test, troubleshooting, and repair of the Multinode Module shown in Figure 1-1 (with front cover installed) and Figure 1-2. The Multinode Module will not have the front cover installed when mounting in Micro TDC 3000 or LCN cabinets. The troubleshooting, disassembly, and assembly procedures are effective down to the optimum replaceable-unit (ORU) level. An ORU parts list is included and is keyed to a module-exploded view that is also used with the disassembly and assembly procedures.

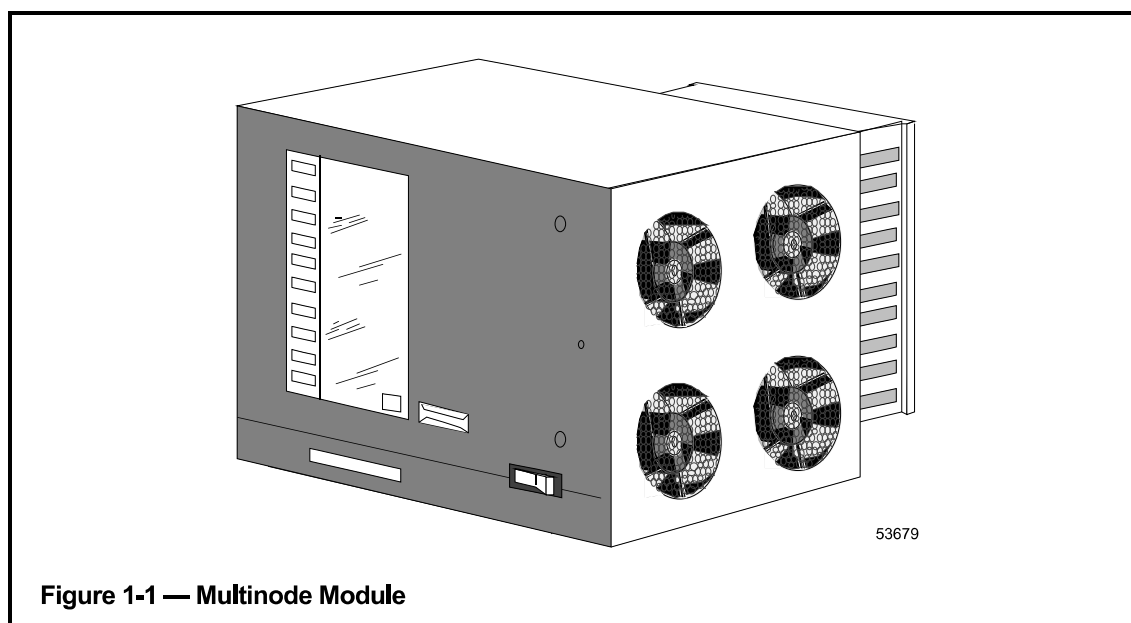

This manual also contains information about the EC compatible Ten-Slot Module. It accommodates both the older and newer EC I/O board designs. The EC card file remains the same in all other details except each I/O board has a faceplate which provides grounding of the board and cable shield to the card file. The fan intake and exhaust openings on the sides of the module are covered with a honeycomb wire mesh for EC Compliant protection. The EC I/O card file is shown in Figure 1-2.

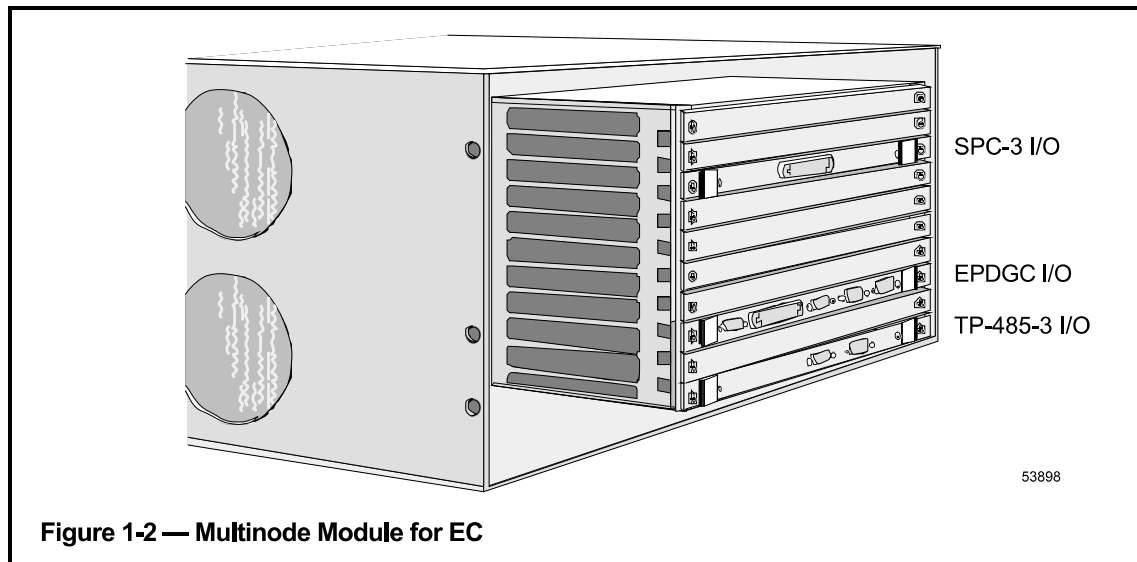

## 1.2 RELATED PUBLICATIONS

The following related publications should be referred to as required and available:

Title	Binder
Maintenance Test Operations	LCN Service/Local Control Network - 1
System Maintenance Guide	LCN Service/Local Control Network - 1
Test System Executive	LCN Service/Local Control Network - 3
Hardware Verification Test System	LCN Service/Local Control Network - 3
Core Module Test System	LCN Service/Local Control Network - 3
8 Node Micro TDC 3000 User's Manual	Implementation/8 Node Micro TDC 3000

## MODULE DESCRIPTION Section 2

### 2.1 GENERAL DESCRIPTION

The Multinode Module is designed to mount either horizontally in a standard NEMA rack or vertically in a cabinet (or tower) designed to stand vertically on the floor. Cooling is provided by four fans in one side of the module enclosure. An integral power supply is located at the bottom (or side) of the module.

Each Multinode Module supports up to four functional nodes in the TDC 3000 System. Each node occupies a specific address on the Local Control Network (LCN). Figure 2-1 illustrates a typical Micro TDC 3000 System using two Multinode Modules in vertical cabinets.

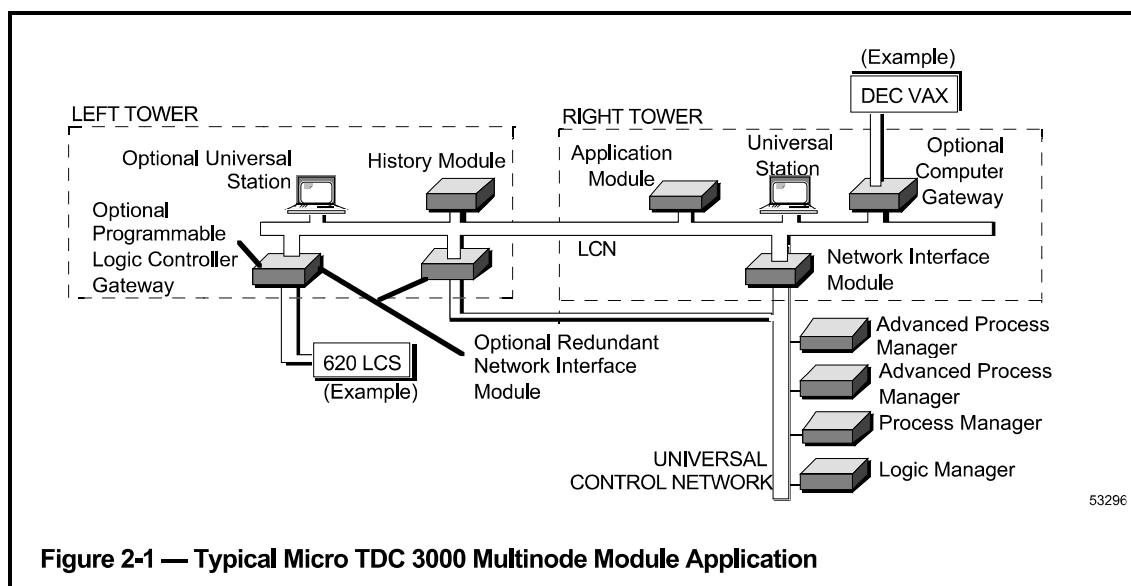

Figure 2-1 — Typical Micro TDC 3000 Multinode Module Application

## 2.2 MODULE AND NODE CONFIGURATIONS

Circuit board slots are numbered from 1 to 10 starting at the bottom (nearest the power supply). When the module is oriented vertically, the slots are numbered from right to left.

Nodes within a single Multinode Module are in a 3/3/2/2 arrangement, with slots 1 through 3 containing the first node, 4 through 6 containing the second node, slots 7 and 8 containing the third node, and slots 9 and 10 containing the fourth node.

The functional control boards are installed in the front card file of the module so that status indicators on the boards may be viewed through the transparent cover. If an Input/Output (I/O) adapter board (or paddleboard) is directly associated with a functional control board, it is installed in the slot behind it in a card file at the rear of the module. Paddleboards which do not perform an I/O function may also be installed in the rear card file in an unused slot.

## 2.2.1 Multinode Module Node Configurations

Because of the limited board space, the boards used to construct various nodes must contain only certain boards and be configured as shown in Table 2-1.

### CAUTION

**Power must be removed from the module whenever you are removing or installing any board, including an I/O paddleboard.** Be sure that an I/O paddleboard is installed in the correct slot; some boards have only one slot that they can be installed in without causing damage. I/O paddleboards plugged into the wrong slot can cause traces on the backplane to burn open.

In the following table, slot numbers are identified by a-b-c. Remember, in the Multinode Module 3/3/2/2 arrangement, slots are grouped by node, therefore, a given node may occupy slots 1-2-3, 4-5-6, 7-8, or 9-10 to match slots a-b-c, or only a-b.

**Table 2-1 — Node Configurations for Multinode Modules**

Application Module (AM)			Universal Station (US)		
Slot	Front	Rear	Slot	Front	Rear
b			c	EPDG	EPDG(P) I/O
a	K2LCN-4/6/8 (4)		b	Empty (3)	
			a	K2LCN-3/4 (5)	(1, 2)
Network Interface Module (NIM)			History Module (HM)		
Slot	Front	Rear	Slot	Front	Rear
b	EPNI	NIM MODEM	b	SPC	SPC I/O
a	K2LCN-2	(1, 2)	a	K2LCN-2	

- Notes:
- (1) A TP485 I/O card is located in Slot 1 and 9 of the modules in the Micro TDC 3000.
  - (2) The TP485 in Slot 9 provides the interface to the twisted pair, short distance ( $\leq 10$  meters) TPLCN.
  - (3) The EPDG board set should be slots 3 and 6 with slots 2 and 5 empty.
  - (4) Standard AM is 4 Mw; optional is 6 Mw and 8 Mw. EC Compliant has 4 Mw and 8 Mw only.
  - (5) Standard US is 4 Mw; optional is 3 Mw. EC Compliant has 4 Mw and 6 Mw only.

(Continued)

**CAUTION**

**Power must be removed from the module whenever you are removing or installing any board, including an I/O paddleboard.** Be sure that an I/O paddleboard is installed in the correct slot; some boards have only one slot that they can be installed in without causing damage. I/O paddleboards plugged into the wrong slot can cause traces on the backplane to burn open.

Note that a given node may occupy slots 1-2-3, 4-5-6, 7-8, or 9-10 to match slots a-b-c, or only a-b.

**Table 2-1 — Node Configurations for Multinode Modules (Continued)**

Computer Gateway (CG)			PLC Gateway (PLCG)		
Slot	Front	Rear	Slot	Front	Rear
c			c		
b	CLI	CLI I/O	b	PLCI	PLCI I/O
a	K2LCN-4		a	K2LCN-2	

Redundant NIM			Network Gateway (NG)		
Slot	Front	Rear	Slot	Front	Rear
b	EPNI	NIM MODEM	b	NGI	NGIO
a	K2LCN-3	(1, 2)	a	K2LCN-2	

- Notes:
- (1) A TP485 I/O card is located in Slot 1 and 9 of the modules in the Micro TDC 3000.
  - (2) The TP485 in Slot 9 provides the interface to the twisted pair, short distance ( $\leq 10$  meters) TPLCN.

## 2.2.2 Multinode Module Node Configurations (CE Compliant)

Because of the limited board space, the boards used to construct various nodes must contain only certain boards and be configured as shown in Table 2-1.

### CAUTION

**Power must be removed from the module whenever you are removing or installing any board, including an I/O paddleboard.** Be sure that an I/O paddleboard is installed in the correct slot; some boards have only one slot that they can be installed in without causing damage. I/O paddleboards plugged into the wrong slot can cause traces on the backplane to burn open.

In the following table, slot numbers are identified by a-b-c. Remember, in the Multinode Module 3/3/2/2 arrangement, slots are grouped by node, therefore, a given node may occupy slots 1-2-3, 4-5-6, 7-8, or 9-10 to match slots a-b-c, or only a-b.

**Table 2-2 — Node Configurations for Multinode Modules (CE Compliant)**

Application Module (AM)			Universal Station (US)		
Slot	Front	Rear	Slot	Front	Rear
b	K2LCN-4/8 (4)		c	EPDG2	EPDGC I/O
a			b	Empty (3)	
			a	K2LCN-4/6 (5)	(1, 2)
Network Interface Module (NIM)			History Module (HM)		
Slot	Front	Rear	Slot	Front	Rear
b	EPNI	NIM MODEM	b	SPC	SPC3 I/O
a	K2LCN-2	(1, 2)	a	K2LCN-2	

- Notes:
- (1) A TP485 I/O card is located in Slot 1 and 9 of the modules in the Micro TDC 3000.
  - (2) The TP485 in Slot 9 provides the interface to the twisted pair, short distance ( $\leq 10$  meters) TPLCN.
  - (3) The EPDG2 board set should be slots 3 and 6 with slots 2 and 5 empty.
  - (4) Standard AM is 4 Mw; optional is 8 Mw. EC Compliant has 4 Mw and 8 Mw only.
  - (5) Standard US is 4 Mw; optional is 3 Mw. EC Compliant has 4 Mw and 6 Mw only.

(Continued)

**CAUTION**

**Power must be removed from the module whenever you are removing or installing any board, including an I/O paddleboard.** Be sure that an I/O paddleboard is installed in the correct slot; some boards have only one slot that they can be installed in without causing damage. I/O paddleboards plugged into the wrong slot can cause traces on the backplane to burn open.

Note that a given node may occupy slots 1-2-3, 4-5-6, 7-8, or 9-10 to match slots a-b-c, or only a-b.

**Table 2-2 — Node Configurations for Multinode Modules (CE Compliant) (Continued)**

Computer Gateway (CG)			PLC Gateway (PLCG)		
Slot	Front	Rear	Slot	Front	Rear
c			c		
b	CLI	CLI I/O	b	PLCI	PLCI I/O
a	K2LCN-2		a	K2LCN-2	

Redundant NIM			Network Gateway (NG)		
Slot	Front	Rear	Slot	Front	Rear
b	EPNI	NIM MODEM	b	NGI	NGFOM
a	K2LCN-4	(1, 2)	a	K2LCN-4	

Notes: (1) A TP485 I/O card is located in Slot 1 and 9 of the modules in the Micro TDC 3000.  
 (2) The TP485 in Slot 9 provides the interface to the twisted pair, short distance ( $\leq 10$  meters) TPLCN. The TP485 in Slot 1 provides the interface to the module temperature sensors.

### 2.2.3 Multinode Module Board Types

The board types listed in Table 2-3 are the current production board types suitable for use in the Multinode Module.

**Table 2-3 — Multinode Module Board Types**

Board Type	Description
CLI	Communications Line Interface Board (PN 80360206-001)
CNI I/O	Communications Network Interface (PN 51304537-100)
CNI I/O	Communications Network Interface I/O Brd (EC) (PN 51304537-200)
EPDG	Enhanced Peripheral Display Generator (PN 51401286-100)
EPDG2	Enhanced Peripheral Display Generator (EC) (PN 51402089-100)
K2LCN-2	High Performance/Density Processor Board (PN 51401551-200)
K2LCN-3	High Performance/Density Processor Board (PN 51401551-300)
K2LCN-4	High Performance/Density Processor Board (PN 51401551-400)
K2LCN-6	High Performance/Density Processor Board (PN 51401551-600)
TP485	TPLCN/Temperature-Sensor Interface Card (PN 51304776-100)
TP485-3	Temp.-Sensor I/O Face Plate w/connector (EC) (PN 51304776-300)
TP485-4	Temp.-Sensor I/O Face Plate w/o connector (EC) (PN 51304776-400)
NIM MODEM	Network Interface Module MODEM Card (PN 51304511-100)
PLCI	Programmable Logic Controller Interface Board (PN 51400997-100)
EPLCI	Enhanced Prog. Logic Controller Interface I/O (PN 51304812-100)
EPNI	Enhanced Process Network Interface Board (PN 51401583-100)
SPC	Smart Peripheral Controller Board (PN 51401052-100)
NGI	Network Gateway Interface Board (PN 51401583-200)
EPDGP I/O	Enhanced Peripheral Display Generator Interface Card (PN 51401286-100)
EPDGC I/O	Enhanced Peripheral Dis. Gen. Int. Card (EC) (PN 51402477-100)
SPC I/O	Smart Peripheral Controller Interface Card (PN 51304156-100)
SPC3	Smart Peripheral Controller Interface Card (EC) (PN 51305088-100)

**Table 2-3 — Multinode Module Board Types (Continued)**

Board Type	Description
CLI I/O	Communications Line Interface I/O Card (RS-232C) (PN 80360209-001)
CLI/B	Comm. Line Interface I/O Card (RS-232C) (EC) (PN 51305090-100)
CLI I/O	Communications Line Interface I/O Card (RS-449) (PN 80360230-001)
CLI/A	Comm. Line Interface I/O Card (RS-449) (EC) (PN 51305091-100)
PLCI I/O	Programmable Logic Controller Interface I/O Card (PN 51195096-100)
PLCI I/O	Prog. Logic Controllers Interface I/O Card (EC) (PN 51195096-200)
NGIO	Network Gateway Interface I/O Card (PN 51304472-100)
CLCN I/O	Local Control Network I/O Card (EC) (PN 51305072-100)
Refer to subsection 2.2.3 Replacement Board Application Notes, for information about compatible replacements.	

## 2.2.4 Replacement Board Application Notes

Table 2-4 lists boards which are dependent upon a minimum software release.

**Table 2-4 — Replacement Board Applications**

BOARD TYPE	MINIMUM DESCRIPTION	SOFTWARE RELEASE *
K2LCN	68020 processor and memory board used in all nodes	320
EPDG	With the EPDGP I/O board, operates the 20" noninterlaced CRT monitor. The EPDGP I/O also has a Cartridge Disk Interface.	320
TP485	Paddleboard that interfaces short-distance LCN used in the Micro TDC 3000, and interfaces the cabinet temperature sensors (sensors on non-CE Compliant equipment only).	320
TP485-3 I/O	I/O board interfaces the current loop interface between the modules located in a Micro TDC 3000 tower.	XXX
TP485-4 I/O	I/O board interfaces the current loop interface between the modules located in a Micro TDC 3000 tower.	XXX

\*All boards are upwards compatible.

## SPARE PARTS Section 5

### 5.1 INTRODUCTION

Table 5-1 lists spare parts for the Multinode Module. Those parts at the ORU level are marked with an asterisk (\*). The listing is arranged in item-number order with the items keyed to the call-out balloons in Figure 4-1. Also listed are those boards suitable for use in the Multinode Module configurations. In some cases, more than one part is assigned to an item number (for instance any one of several board assemblies can occupy a slot in the module). In this situation, the list is in part-number order.

**Table 5-1 — Parts List**

ITEM	PART NUMBER	DESCRIPTION
1	51400919-100	10-Slot Module Cover Assembly (may not be required)
2*	51400955-100	PNI Board Assembly, Process Network Interface
2*	51400955-100	EPNI/NGI
2*	51400997-100	PLCI Programmable Logic Controller Interface
2*	51401052-100	SPC Board Assy., Smart Peripheral Interface Controller
2*	51401286-100	EPDG Board Assy., Enhanced Peripheral Display Generator
2*	51401286-100	EPDG2 Board Assy.
2*	51401551-200	K2LCN Board Assembly, Processor (LCN Intf & 2 M Memory)
2*	51401551-300	K2LCN Board Assembly, Processor (LCN Intf & 3 M Memory)
2*	51401551-301	K2LCN Board Assembly
2*	51401551-400	K2LCN Board Assembly, Processor (LCN Intf & 4 M Memory)
2*	51401551-600	K2LCN Board Assembly, Processor (LCN Intf & 6 M Memory)
2*	51401551-601	K2LCN Board Assembly
2*	51401583-100	EPNI Board Assembly, Enhanced Process Network Interface

(Continued)

Table 5-1 — Parts List (Continued)

PART ITEM	NUMBER	DESCRIPTION
2*	51401583-200	NGI Board Assembly, Network Gateway Interface
2*	80360206-001	CLI Board Assembly, Computer/LCN Interface
3*	51401782-100	3/3/2/2 Split Node Cardfile (w/out power supply, fan assembly)
3*	51402491-100	3/3/2/2 Split Node Cardfile, (EC)
4*	51195066-200	Power Supply
4*	51196654-100	10-Slot Pwr Supply w/Temp Sense Sw. (EC)
5*	51400647-100	10-Slot Fan Assembly (large)
6*	51304511-100	NIM MODEM Adapter Board Assembly
6*	51304511-200	NIM MODEM Adapter Board Assembly (EC)
6*	51304156-100	SPC I/O Adapter Board Assembly
6*	51305088-100	SPC3 I/O Adapter Board Assembly, (EC)
6*	51304584-100	EPDGC I/O Adapter Board Assembly, (EC)
6*	51304584-100	EPDGP I/O Adapter Board Assembly
6*	51304776-100	TP485 Adapter Board Assembly
6*	51304472-100	NGIO Adapter Board Assembly
6*	80360209-001	CLI I/O Adapter Board Assembly (RS-232C)
6*	51305090-100	CLI/B Card (RS-232C) (EC)
6*	80360230-001	CLI I/O Adapter Board Assembly (RS-449)
6*	51305091-100	CLI/A Card (RS-449) (EC)
6*	51304537-100	CNI Communications Network Interface
6*	51304537-200	CNI I/O Communications Network Interface I/O Brd, (EC)
6*	51195096-100	PLCI I/O Adapter Board Assembly
6*	51195096-200	PLCI I/O Adapter Board Assembly (EC)

(Continued)

**Table 5-1 — Parts List (Continued)**

PART ITEM	NUMBER	DESCRIPTION
*	51304421-100	PLCG Relay Panel Assembly
*	51304421-200	PLCG Relay Panel Assembly (EC)
	51303508-100	Power Cord, 125 V
	51303508-200	Power Cord, 250 V
	51308115-100	Power Cord (EMI Filter), 120/240 V (EC)
	51191840-X0X	Power Cable, Shielded, PVC Jacket, 120/240 V (EC)