

Chapter 2 – Overview

Overview

This chapter contains a short description of the Analogue I/O Extension module, a delivery checklist and warranty information.

The RAIO-01 module

The RAIO-01 Analogue I/O Extension module offers two bipolar current ($\pm 0[4] \dots 20$ mA) or voltage ($\pm 0[2] \dots 10$ V or $\pm 0 \dots 2$ V) inputs and two unipolar current ($0[4] \dots 20$ mA) outputs with 12-bit resolution. The analogue inputs and outputs are galvanically isolated as a group from each other and the power supply.

Module layout

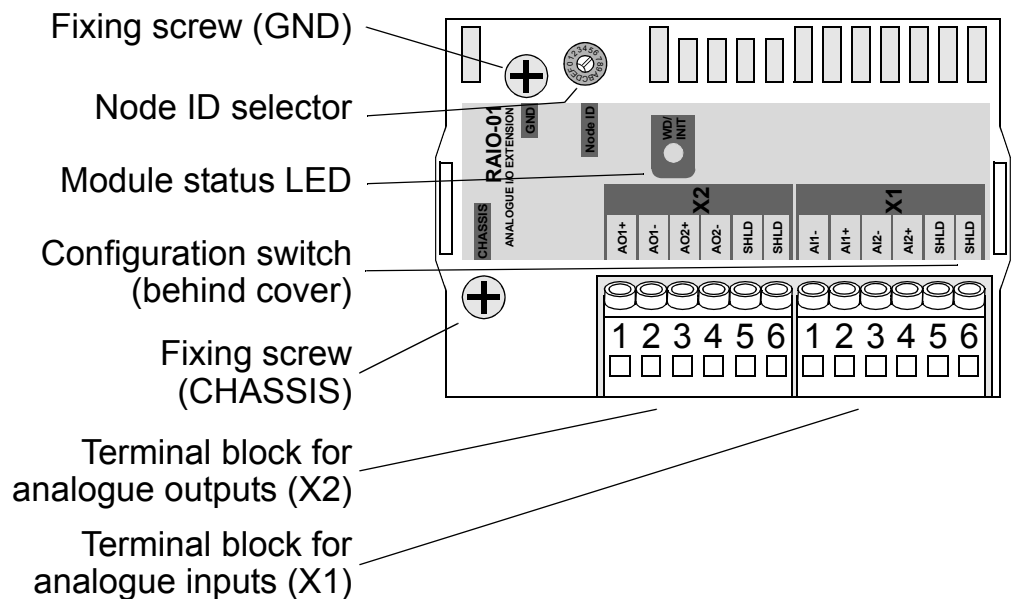

Delivery check The option package contains:

- RAIO-01 module
- Two screws
- This manual.

Compatibility The RAIO-01 is compatible with the ACS800 Standard Application Program version ASXR7000 or later.

Warranty and liability information The warranty for your ABB drive and options covers manufacturing defects. The manufacturer carries no responsibility for damage due to transport or unpacking.

In no event and under no circumstances shall the manufacturer be liable for damages and failures due to misuse, abuse, improper installation, or abnormal conditions of temperature, dust, or corrosives, or failures due to operation above rated capacities. Nor shall the manufacturer ever be liable for consequential and incidental damages.

The period of manufacturer's warranty is 12 months, and not more than 18 months, from the date of delivery. Extended warranty may be available with certified start-up. Contact your local distributor for details.

Your local ABB Drives company or distributor may have a different warranty period, which is specified in their sales terms, conditions, and warranty terms.

If you have any questions concerning your ABB drive, contact your local distributor or ABB Drives office.

The technical data and specifications are valid at the time of printing. ABB reserves the right to subsequent alterations.

Appendix A – Technical data

Dimensions:

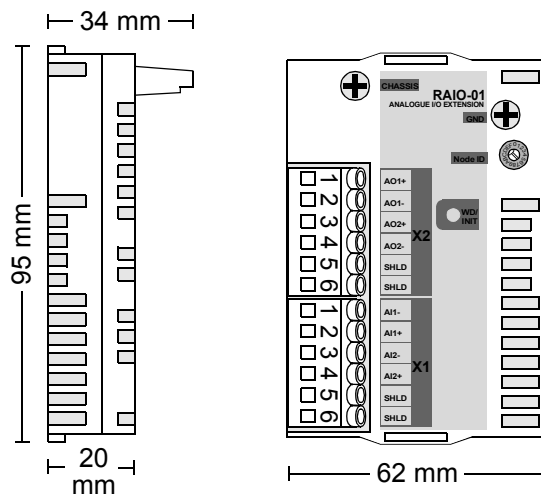

Mounting: Into an option slot of the RMIO board of the drive or onto external AIMA-01 I/O Module Adapter.

Degree of protection: IP 20

Ambient conditions: The applicable ambient conditions specified for the drive in its *Hardware Manual* are in effect.

Hardware settings:

- Rotary switch for node ID selection (range 1...15)
- One DIP switch per input for selection between bipolar mode (default) and unipolar mode
- Two DIP switches per input for signal type and level selection

Connectors:

- 38-pin parallel bus connector
- Two 6-pole non-detachable screw-type terminal blocks for max. 2.5 mm² wire

Analogue inputs:

- Signal types: $\pm(0)4\dots 20$ mA, $\pm(0)2\dots 10$ V, $\pm 0\dots 2$ V
- Input impedance: 100 Ω (current), 200 k Ω (voltage)
- Resolution in unipolar mode: 0.024% (12 data bits)
- Resolution in bipolar mode: 0.048% (11 data bits + sign)
- Inaccuracy: $\pm 0.5\%$ (Full Scale Range) at 25 °C
Temperature coefficient: ± 100 ppm/°C max.
- Isolated from the analogue outputs and the module carrier board. The maximum continuous isolation voltage is 48 V rms; the maximum peak value is 100 V. The isolation towards the chassis potential (e.g. GND and +24 VDC of the module carrier board) has been tested at 1.5 kV AC for 1 s.
- Common mode voltage: ± 15 V max.
- HW filtering: 2 ms approx.

Analogue outputs:

- Signal type: 0(4) $\dots 20$ mA
- Load resistance max.: 700 Ω
- Resolution: 0.024% (12 bits)
- Inaccuracy: $\pm 0.5\%$ (Full Scale Range) at 25 °C
Temperature coefficient: ± 100 ppm/°C max.
- Isolated from the analogue inputs and the module carrier board. The maximum continuous isolation voltage is 48 V rms; the maximum peak value is 100 V. The isolation towards the chassis potential (e.g. GND and +24 VDC of the module carrier board) has been tested at 1.5 kV AC for 1 s.

General

- Max. power consumption:
100 mA (5 V) + 120 mA (24 V)
Both voltages supplied by the RMIO board or
AIMA-01 I/O Module Adapter
- Estimated min. lifetime: 100 000 h
- All materials UL/CSA-approved
- Complies with EMC standards EN 50081-2 and
EN 50082-2