

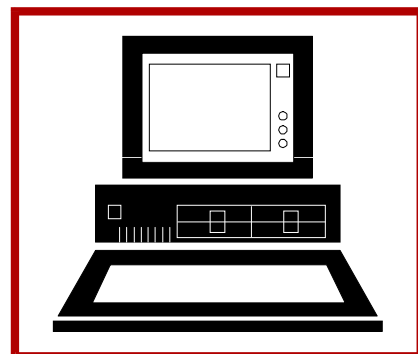

IMDSO14

Instruction

Digital Output Module

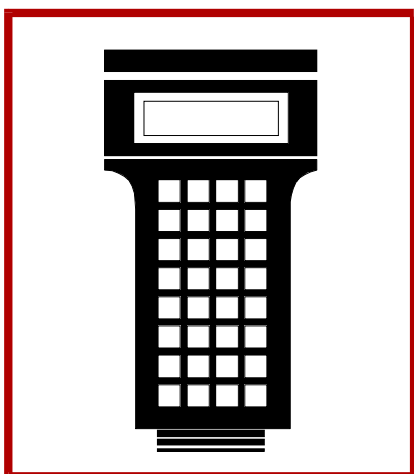
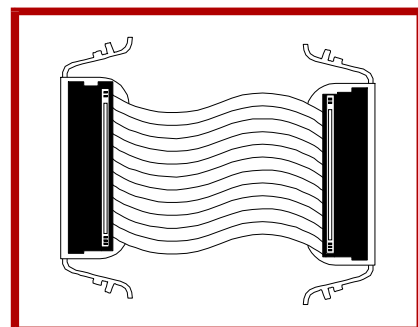
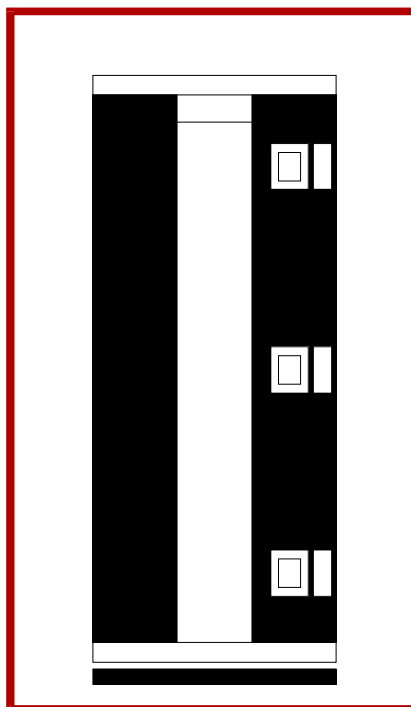
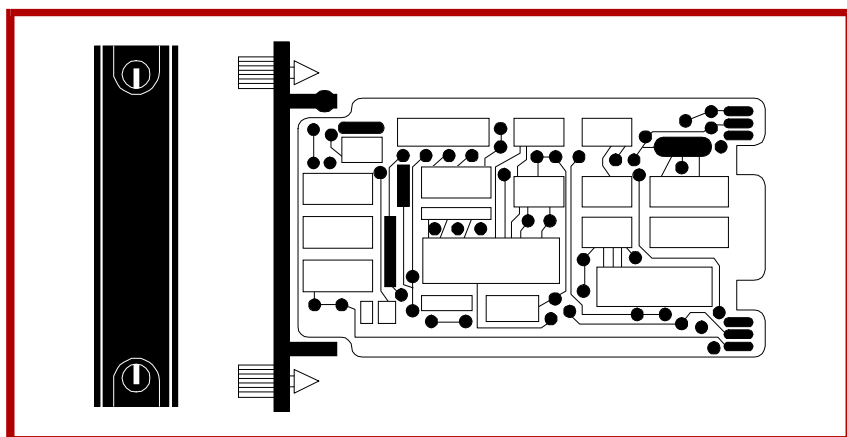
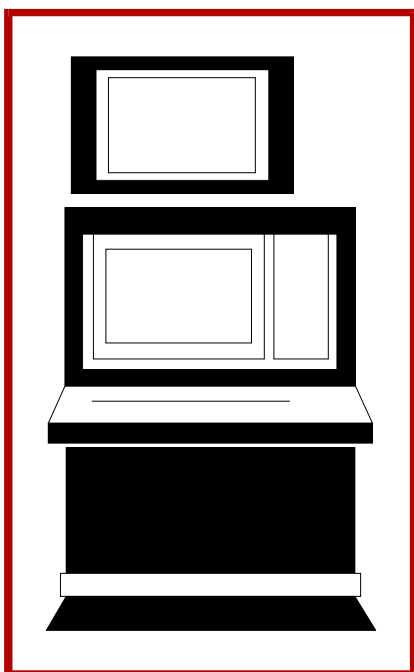

WARNING notices as used in this instruction apply to hazards or unsafe practices that could result in personal injury or death.

CAUTION notices apply to hazards or unsafe practices that could result in property damage.

NOTES highlight procedures and contain information that assists the operator in understanding the information contained in this instruction.

WARNING

INSTRUCTION MANUALS

DO NOT INSTALL, MAINTAIN, OR OPERATE THIS EQUIPMENT WITHOUT READING, UNDERSTANDING, AND FOLLOWING THE PROPER **Elsag Bailey** INSTRUCTIONS AND MANUALS; OTHERWISE, INJURY OR DAMAGE MAY RESULT.

RADIO FREQUENCY INTERFERENCE

MOST ELECTRONIC EQUIPMENT IS INFLUENCED BY RADIO FREQUENCY INTERFERENCE (RFI). CAUTION SHOULD BE EXERCISED WITH REGARD TO THE USE OF PORTABLE COMMUNICATIONS EQUIPMENT IN THE AREA AROUND SUCH EQUIPMENT. PRUDENT PRACTICE DICTATES THAT SIGNS SHOULD BE POSTED IN THE VICINITY OF THE EQUIPMENT CAUTIONING AGAINST THE USE OF PORTABLE COMMUNICATIONS EQUIPMENT.

POSSIBLE PROCESS UPSETS

MAINTENANCE MUST BE PERFORMED ONLY BY QUALIFIED PERSONNEL AND ONLY AFTER SECURING EQUIPMENT CONTROLLED BY THIS PRODUCT. ADJUSTING OR REMOVING THIS PRODUCT WHILE IT IS IN THE SYSTEM MAY UPSET THE PROCESS BEING CONTROLLED. SOME PROCESS UPSETS MAY CAUSE INJURY OR DAMAGE.

AVERTISSEMENT

MANUELS D'OPÉRATION

NE PAS METTRE EN PLACE, RÉPARER OU FAIRE FONCTIONNER L'ÉQUIPEMENT SANS AVOIR LU, COMPRIS ET SUIVI LES INSTRUCTIONS RÉGLEMENTAIRES DE **Elsag Bailey**. TOUTE NÉGLIGENCE À CET ÉGARD POURRAIT ÊTRE UNE CAUSE D'ACCIDENT OU DE DÉFAILLANCE DU MATÉRIEL.

PERTURBATIONS PAR FRÉQUENCE RADIO

LA PLUPART DES ÉQUIPEMENTS ÉLECTRONIQUES SONT SENSIBLES AUX PERTURBATIONS PAR FRÉQUENCE RADIO. DES PRÉCAUTIONS DEVRONT ÊTRE PRISES LORS DE L'UTILISATION DU MATÉRIEL DE COMMUNICATION PORTATIF. LA PRUDENCE EXIGE QUE LES PRÉCAUTIONS À PRENDRE DANS CE CAS SOIENT SIGNALÉES AUX ENDROITS VOULUS DANS VOTRE USINE.

PERTURBATIONS DU PROCÉDÉ

L'ENTRETIEN DOIT ÊTRE ASSURÉ PAR UNE PERSONNE QUALIFIÉE EN CONSIDÉRANT L'ASPECT SÉCURITAIRE DES ÉQUIPEMENTS CONTRÔLÉS PAR CE PRODUIT. L'AJUSTEMENT ET/OU L'EXTRACTION DE CE PRODUIT PEUT OCCASIONNER DES À-COUPS AU PROCÉDÉ CONTRÔLE LORSQU'IL EST INSÉRÉ DANS UNE SYSTÈME ACTIF. CES À-COUPS PEUVENT ÉGALEMENT OCCASIONNER DES BLESSURES OU DES DOMMAGES MATÉRIELS.

NOTICE

The information contained in this document is subject to change without notice.

Elsag Bailey, its affiliates, employees, and agents, and the authors and contributors to this publication specifically disclaim all liabilities and warranties, express and implied (including warranties of merchantability and fitness for a particular purpose), for the accuracy, currency, completeness, and/or reliability of the information contained herein and/or for the fitness for any particular use and/or for the performance of any material and/or equipment selected in whole or part with the user of/or in reliance upon information contained herein. Selection of materials and/or equipment is at the sole risk of the user of this publication.

This document contains proprietary information of Elsag Bailey, Elsag Bailey Process Automation, and is issued in strict confidence. Its use, or reproduction for use, for the reverse engineering, development or manufacture of hardware or software described herein is prohibited. No part of this document may be photocopied or reproduced without the prior written consent of Elsag Bailey.

The IMDSO14 Digital Output module outputs 16 separate digital signals from the INFI 90[®] OPEN Strategic Process Management System to a process. These digital outputs are used by control modules to control (switch) process field devices.

There are five versions of the digital output module.

- IMDSO01/02/03.
- IMDSO14.
- IMDSO15.

This manual covers the (IMDSO14). The difference between the IMDSO14 module and the IMDSO01/02/03 is in the output circuitry, switching capabilities, and EMI protection circuitry. Refer to product instruction I-E96-310 for information on the IMDSO01/02/03.

The difference between the IMDSO14 module and the IMDSO04 module is in the EMI protection circuitry. Additionally, the IMDSO14 module will handle 24 or 48 VDC load voltages; the IMDSO04 is for 24 VDC only. Refer to product instruction I-E96-313 for information on the IMDSO04 module. The IMDSO14 module may be used as a direct replacement for the IMDSO04 module.

The IMDSO15 module provides electromechanical relay contacts for field devices. Refer to product instruction WBPEEUI240754A0 for information on the IMDSO15 module.

This instruction explains the IMDSO14 digital output module specifications and operation. It details the procedures necessary to complete setup, installation, maintenance, troubleshooting and replacement of the IMDSO14 digital output module.

SECTION 1 - INTRODUCTION

OVERVIEW

The IMDSO14 Digital Output module (DSO) outputs 16 digital signals from the INFI 90 OPEN system to control a process. It is an interface between the process and the INFI 90 OPEN Strategic Process Management System. The signals provide digital switching (ON or OFF) for field devices. Control modules perform the control functions; I/O modules provide the input/output functions.

Figure 1-1 illustrates the INFI 90 OPEN communication levels and the position of the digital output modules within these levels.

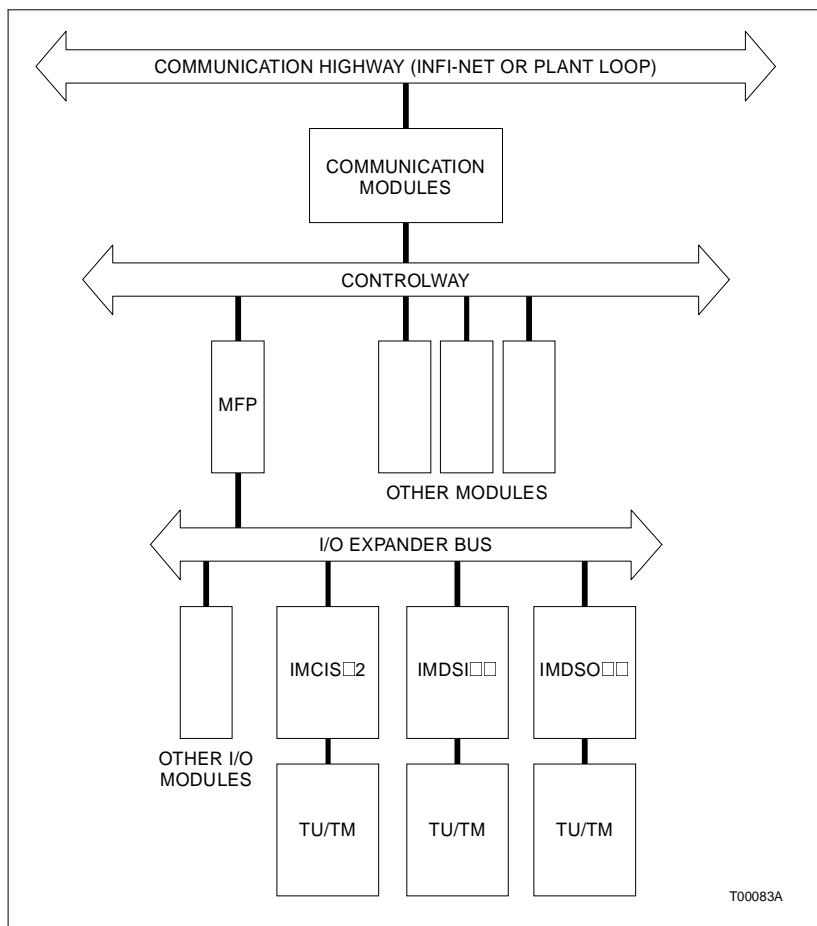

Figure 1-1. INFI 90 OPEN Communication Levels

INTENDED USER

This instruction is written for engineers, technicians and system designers as a source of technical information on the IMDSO14 digital output modules. This instruction should be

used by those planning to purchase, install, operate, troubleshoot, maintain or replace these modules. Those working with the digital output module should have experience working with and know the precautions to take around AC/DC power. A knowledge of the INFI 90 OPEN system and electronic principles is also required.

MODULE DESCRIPTION

The DSO module consists of a single printed circuit board that occupies one slot in a module mounting unit (MMU). It outputs 16 separate digital signals through solid state circuits on the printed circuit board. Twelve outputs are isolated from each other; the remaining two pairs share common positive output lines.

Two captive screws on the faceplate secure the module to the MMU. The upper two front panel red and green LEDs indicate the module operating status. The 16 lower front panel red LEDs (group A and group B) display the module output states (ON or OFF).

The DSO module has three card edge connectors for external signals and power (P1, P2 and P3). P1 connects to logic power (+5 VDC) that drives the module circuits. P2 connects the module to the I/O expander bus to communicate with a control module. P3 outputs the digital signals using a cable connected to a termination unit (TU) or a termination module (TM). The terminal blocks (physical connection points) for field wiring are on the TU or TM.

INSTRUCTION CONTENT

This instruction is divided into eight sections and four appendices. Read this instruction before installing or operating the IMDSO14 digital output module. A summary of section content follows:

Introduction	Contains a brief description, general usage information and technical specifications.
Description and Operation	Uses block diagrams and schematics to explain module operation and input circuitry.
Installation	Covers the preliminary steps to install the module and prepare for operation. It covers address switch settings, mounting, wiring connections, cabling and preoperational checks.
Operating Procedures	Provides information on front panel indicators and start-up procedures.
Troubleshooting	Explains the meaning of error indications and contains troubleshooting procedures.

Maintenance	Contains scheduled maintenance tasks and procedures.
Repair and Replacement Procedures	Contains procedures that explain how to replace the module.
Support Services	Explains the services and training that Elsig Bailey makes available to, their customers.
Appendices	Appendix A provides configuration information for the NTDI01 termination unit. Appendix B provides configuration information for the NIDI01 termination module. Appendix C provides configuration information for the NTDO02 termination unit. Appendix D provides a quick reference for module switch location and settings.

HOW TO USE THIS MANUAL

Read this instruction before handling the IMDSO14 digital output module. Refer to a specific section for information as needed.

1. Read the operating procedures section before installing the module.
2. Do the steps in the installation section.
3. Refer to the troubleshooting section to resolve problems if they occur.
4. Refer to the maintenance section for scheduled maintenance requirements.
5. Refer to the repair and replacement procedures to replace a module.
6. Use the support services section for information on ordering spare modules and warranty information.

DOCUMENT CONVENTIONS

The □ in a nomenclature item indicates variables for that position, i.e., IMDSO□□.

GLOSSARY OF TERMS AND ABBREVIATIONS

Table 1-1 contains those terms and abbreviations that are unique to Elsig Bailey or have a definition that is different from standard industry usage.

Table 1-1. Glossary of Terms and Abbreviations

Term	Definition
EWS	Engineering work station.
Function Code (FC)	An algorithm which manipulates specific functions. These functions are linked together to form the control strategy.
I/O Expander Bus	Parallel communication bus between the control and I/O modules.
MFP	Multi-function processor module. A multiple loop controller with data acquisition and information processing capabilities.
MMU	Module mounting unit. A card cage that provides electrical and communication support for INFI 90 OPEN/Network 90 modules.
OIS	Operator interface station. Integrated operator console with data acquisition and reporting capabilities. It provides a digital access into the process for flexible control and monitoring.
TM	Termination module. Provides input/output direct connection between plant equipment and the INFI 90 OPEN/Network 90 modules.
TU	Termination unit. Provides input/output direct connection between plant equipment and the INFI 90 OPEN/Network 90 modules.

REFERENCE DOCUMENTS

Table 1-2 lists Elsag Bailey instructions for equipment that is referenced in this instruction.

Table 1-2. Reference Documents

Number	Document
I-E92-501-2	Configuration and Tuning Terminal (CTT)
I-E96-192-1	Operation, Operator Interface Station (40 Series) IIOIS42
I-E96-200	Function Code Application Manual
I-E96-201	Multi-Function Processor (IMMFP01)
I-E96-202	Multi-Function Processor (IMMFP02)
I-E96-203	Multi-Function Processor (IMMFP03/03B)
I-E96-209	Logic Master Module (IMLMM02)
I-E96-410	Termination Module (NIDI01)
I-E96-424	Termination Unit (NTDI01)
I-E96-431	Termination Unit (NTDO02)
WBPEEU200502A0	Module Mounting Unit (IEMMU11/12/21/22)
WBPEEU220756A0	Operation, Operator Interface Station (40 Series) IIOIS43

NOMENCLATURE

Table 1-3 contains the digital output module nomenclature used in this instruction.

Table 1-3. Nomenclature

Nomenclature	Description
IMDSO14	Digital output module

RELATED HARDWARE

Refer to Table 1-4 for modules and equipment that can be used with the digital output module:

Table 1-4. Related Hardware

Nomenclature	Description
IMMFP01/02/03/03B	Multi-function processor module
IMLMM02	Logic master module
NIDI01	Termination module
NTDI01	Termination unit
NTDO02	Termination unit
NKDO01/11	Cable, termination unit
NKTM01	Cable, termination module
NKTU01/11	Cable, termination unit
NKTU02/12	Cable, termination module

SPECIFICATIONS

Table 1-5. Specifications

Property	Characteristic/Value
Power requirements	
Voltage	5 VDC (±5%)
Current	275 mA (typical) 370 mA (maximum)
Dissipation (logic only)	1.375 W (typical) 1.850 W (maximum)
Overvoltage category on outputs	II, per IEC 1010-1
Outputs	16 digital
Load voltage	24 VDC, 48 VDC
Load current (maximum)	250 mA (24 VDC), 125 mA (48 VDC)
Off leakage current (maximum)	10 µA at 70°C (158°F)
On voltage drop (maximum)	2 V at 70°C (158°F)
Current consumption	150 mA (typical), 250 mA (maximum) per output at 24 VDC 75 mA (typical), 125 mA (maximum) per output at 48 VDC

Table 1-5. Specifications (continued)

Property	Characteristic/Value		
Isolation (IEC 1010-1, IEC 255, IEC 60) Channel to channel and channel to logic	Test	Common Mode	Normal Mode
	Insulation resistance (100/500 VDC)	100 MΩ	N/A
	Dielectric VAC (45 - 65 Hz) or VDC	1 kV rms/1min. or 1.5 kV DC/1min.	N/A
	Impulse voltage (1.2/50 μS)	±2 kVp	±1 kVp
Electromagnetic compatibility Conducted transients	Test	Common Mode	Normal Mode
	Voltage/current surge (1.2/50 μS to 8/20 μS) (IEC 1000-4-5, EN 61000-4-5)	±2 kVp	±1 kVp
	Fast transient bursts (IEC 1000-4-4, EN 61000-4-4)	±2 kVp	N/A
	Damped oscillatory wave, 0.1 MHz and 1 MHz (IEC 1000-4-12, EN 61000-4-12)	±2 kVp	±1 kVp
	Ring wave (IEC1000-4-12, EN 61000-4-12)	±2 kVp	±1 kVp
Electrostatic discharge (IEC 1000-4-2, EN 61000-4-2)	Contact: ±6 kV Air: ±8 kV		
Magnetic and electromagnetic fields			
Power frequency magnetic field (IEC 1000-4-8, EN 61000-4-8)	Continuous: 30 A/m (rms) Short duration: 300 A/m (rms)		
Pulse magnetic field (IEC 1000-4-9, EN 61000-4-9)	Peak value: 300 A/m		
Damped oscillatory magnetic field, 0.1 MHz and 1 MHz (IEC 1000-4-10, EN 61000-4-10)	Peak value: 30 A/m		
Radiated radio frequency electromagnetic field, 80 MHz to 1 GHz (ENV 50140)	Unmodulated rms: 10 V/m Amplitude modulated: 80% AM (1 kHz)		
Radiated radio frequency field, 900 ±5 MHz (ENV 50204)	Unmodulated rms: 10 V/m Pulse modulated: Duty cycle 50% Rep. cycle 200 Hz		
Radio frequency common mode, amplitude modulated, 0.15 MHz to 80 MHz (ENV 50141)	Unmodulated rms: 10 V/m Amplitude modulated: 80% AM (1 kHz) Source impedance: 150 Ω		
Emission test RF radiated fields, 30 MHz to 1000 MHz (ENV 55011)	Class A		

Table 1-5. Specifications (continued)

Property	Characteristic/Value
Mounting	Occupies one slot in a standard INFI 90 OPEN module mounting unit
Environmental Ambient temperature (per IEC-68-2-1, 2,14) Relative humidity (per IEC-68-2-3) Atmospheric pressure Air quality (per ISA S71.04, Class LA, LB, LC - level 1)	Temperature rating within the cabinet or enclosure applies. INFI 90 OPEN internal cabinet rating: 0° to 70° C (32° to 158° F) 5% to 95% up to 55°C (131°F)(noncondensing) 5% to 45% at 70°C (158°F)(noncondensing) Pollution degree: 1 (no condensation) Sea level to 3 km (1.86 miles) Noncorrosive
CE Mark Declaration EMC96 Directive 89/336/EEC Low Voltage Directive 73/23/EEC	This product, when installed in an INFI 90 OPEN cabinet, complies with the following Directives/Standards requested for CE marking: EN 50081-2 Generic Emission Standard - Part 2: Industrial Environment EN 50082-2 Generic Immunity Standard - Part 2: Industrial Environment EN 61010-1 Safety Requirement for Electrical Equipment for Measurement, Control and Laboratory Use - Part 1: General
Certifications (pending) CSA (Canadian Standards Association) FM (Factory Mutual)	Certification for use as process control equipment in an ordinary (nonhazardous) location per CSA C22.2 No. 1010.1-92 Approval for the following categories: Nonincendive for: Class I, Division 2, Groups A,B,C,D Class II, Division 2, Groups F,G

SPECIFICATIONS SUBJECT TO CHANGE WITHOUT NOTICE.

SECTION 2 - DESCRIPTION AND OPERATION

INTRODUCTION

This section explains the output circuitry, control logic, data, logic power and connections for the IMDSO14 Digital Output (DSO) module. The DSO is a digital signal interface between a multi-function processor (MFP), multi-function controller (MFC) or logic master module (LMM) and process field devices. The control module communicates with its I/O module on an I/O expander bus (Fig. 1-1). Each I/O module on the bus has a unique address set by its address dipswitch (S1).

DIGITAL OUTPUTS

Digital signals have two states, ON or OFF. The DSO module digital outputs switch voltages of 24 VDC at 250 milliamps or 48 VDC at 125 milliamps. This voltage energizes (turns on) and de-energizes (turns off) a field device or relay.

MODULE BLOCK DIAGRAM

The DSO consists of registers, buffers and interface circuits. They control the digital output switching, and transmit I/O module operating status back to a control module. Open collector transistors provide the switching functions. Optocouplers isolate the module circuits from the process.

The DSO has two sets of circuits to control its 16 outputs. One controls group A outputs; the other controls group B outputs. Both receive their data from a single I/O expander bus interface. Figure 2-1 is a block diagram of the DSO module. It illustrates signal flow through the module. Figure 2-2 shows the digital output circuit.

Digital Output Circuits

Sixteen open collector transistors in the digital output block function as digital switches. Optocouplers for each output provide isolation between the module circuits and the process field device. All outputs are normally de-energized (OFF) until a signal from the data selector block causes them to energize (ON). The output circuits provide 1.5 kV isolation between output and logic circuits, and other output channels.

NOTE: Due to the number of pins on the P3 connector, 12 outputs are separate while the remaining two pairs share output terminals. The positive (+) sides of outputs 7 and 8 are tied together for each group (refer to Table 5-4). They are not isolated from each other, but are isolated from the module circuitry.

The data selector block drives the output circuits and lights the front panel output status LEDs. It uses data from the output register or default register to do this. During normal operation, it selects the output register data.

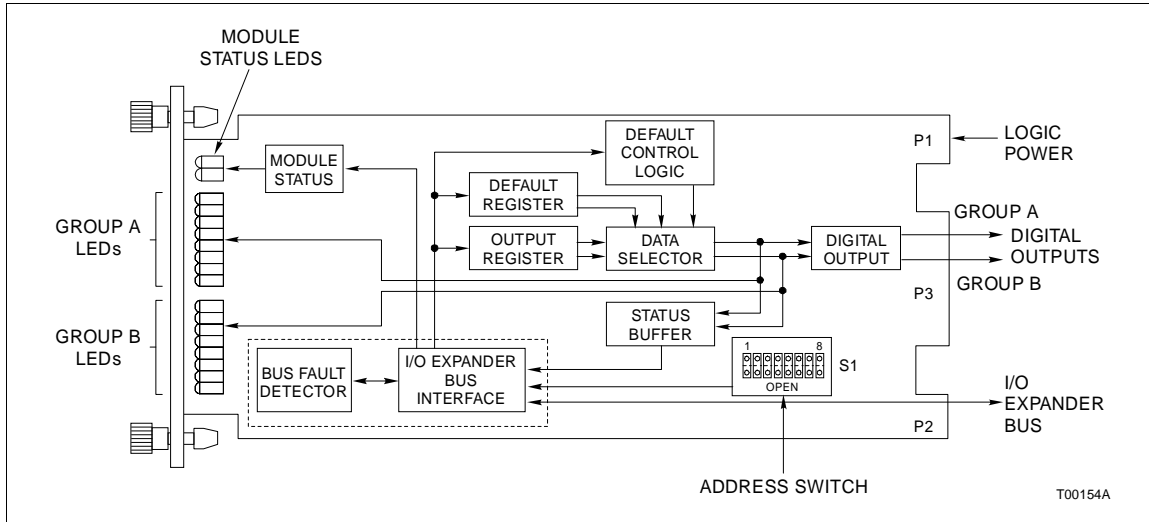

Figure 2-1. Block Diagram

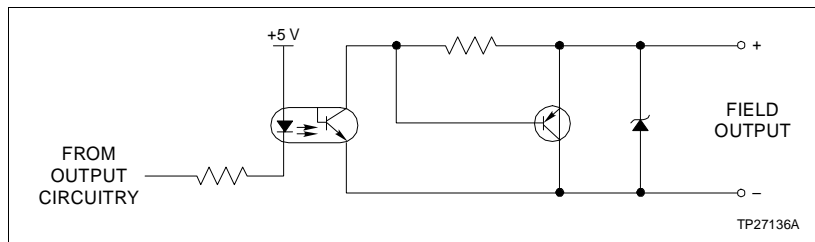

Figure 2-2. Digital Output Circuit

Output Control Logic

An output register holds the data that controls the outputs. The I/O expander bus interface writes control module data to this register. This data, sent to the data selector, determines the output states (ON or OFF).

Default data from the control module is sent to the default register. The control module configuration sets the default values (Function Code 128). The default register is reset to logic zeros during power up to drive the outputs to a de-energized state. FC 128 in the control module configuration selects the output values used to drive the output circuits in the event of a control module failure (*time-out*). If FC 128 is not defined, the outputs will go to a de-energized state during a *time-out*. Refer to **BUS FAULT TIMER** in this section for further explanation of *time-out*.

The default control logic block is a one bit latch register. It sends a signal to the data selector block to select either the default register data or the output register data during a *time-out* (indicating a control module error). This signal is dependent on the control module configuration (FC 83 specification S2). The bus fault detector in the I/O expander bus interface checks for a *time-out* condition. During a *time-out*, the data selector block normally selects the default register data. If a *hold* option is selected in FC 83, the default control logic circuits send a logic 1 to override the data selector. It causes the data selector to drive the outputs with the output register data instead of default data to maintain the outputs at their current values (*hold*).

Status Logic

The status buffer block provides module status information to the control module. This information is output states, and module identification and status. The control module reads this data through the I/O expander bus interface. Refer to **Output Control Logic** in this section for an explanation of the data.

OUTPUT CIRCUIT CONNECTIONS

The output signals connect to the 30-pin card edge connector P3 of the DSO using a termination cable from a termination unit (TU) or a termination module (TM). Proper polarity wiring of field signals is necessary for the output circuits to function properly.

I/O EXPANDER BUS

The INFI 90 OPEN I/O expander bus is a high speed synchronous parallel bus. It provides a communication path between control modules and I/O modules. The control module provides the control functions and the I/O module provides the input/output functions. The P2 card edge connector of the I/O module and control module connect to the bus.

The I/O expander bus is parallel signal lines located on the module mounting unit (MMU) backplane. A 12-position dipshunt placed in a connection socket on the MMU backplane connects the bus between the control and I/O modules. Cable assemblies can extend the bus to six MMUs.

A control module and its I/O modules form an individual subsystem within a process control unit (PCU). The I/O expander bus between control and I/O subsystems must be separated. Leaving a dipshunt socket empty or not connecting the MMUs with cables separates them.

UNIVERSAL I/O EXPANDER BUS INTERFACE

The DSO uses a custom gate array to perform the I/O expander bus interface function. All the control logic and communication protocol are built into an integrated circuit (IC). This IC provides the following functions:

- Address comparison and detection.
- Function code latching and decoding.
- Read strobe generation.
- Data line filtering of bus signals.
- On-board bus drivers.

MODULE DATA

FC 83 in the control module configuration accesses the DSO on the I/O expander bus. It also allows the control module to automatically read status data from the I/O module, and write output data to it. The I/O module address in FC 83 must be the same as the address set on the I/O address dipswitch (S1).

Status Data

Status data consists of three separate 8-bit bytes read by the control module. The first and second bytes contain readback data that reflects the state of group A and group B outputs. Each bit of this data corresponds to the digital output state (ON or OFF).

The third byte is the module identification and module status. I/O module identification is in the four most significant bits (MSB). It identifies the I/O module to the control module. It also verifies the I/O expander bus communication integrity and the control module configuration. I/O module status is the least significant bit (LSB). During initialization, the control module writes data to the output register and default register, and forces this bit to a logic 1. A reset or *time-out* (bus fault error) resets it to a logic 0. Default data is normally written only during control module start-up. The control module reads the module status bit to test for a change in the state of the module. It uses this bit as a signal to rewrite data to the module to ensure that proper default values are in the default register.

Output Data

Output data is two 8-bit bytes sent to the output registers. Each byte corresponds to group A and group B outputs. Each bit of data represents one output. The bit value reflects the state of the output. Logic 1 turns a field device ON; logic 0 turns it OFF.

Default Data

Default data is two 8-bit bytes sent to the default registers. It is set by the control module configuration (FC 128). The function of this data is the same as the output data but is used only when a *time-out* occurs.

LOGIC POWER

Logic power (+5 VDC) drives the DSO circuits. It connects through the top 12-pin card edge connector (P1) shown in Figure 2-1.

BUS FAULT TIMER

The bus fault timer is a one-shot timer that is reset by the I/O expander bus clock; the control module generates the bus clock. If the clock stops (indicating a control module error or failure), the bus fault timer times out in 10 milliseconds. This causes the digital outputs to change to their default values. A red front panel status LED indicates a bus fault (time-out).

STATUS LED INDICATOR

Two front panel module status LED indicators show the operating state of the DSO. Circuits on the DSO determine the module status and light the LED accordingly. **OPERATING PROCEDURES** in Section 4 explains the indications, and **TROUBLESHOOTING** in Section 5 explains corrective actions to take.

SECTION 3 - INSTALLATION

INTRODUCTION

This section explains the procedures required to place the IMDSO14 Digital Output module into operation. It includes instructions on setting the address selection switch, setup and physical installation and wiring and cable connections. **DO NOT PROCEED** with operation until you read, understand and complete the steps in the order in which they appear.

SPECIAL HANDLING

NOTE: Always use the Eltag Bailey field static kit (part number 1948385□1), consisting of two wrist straps, ground cord assembly, alligator clip, and static dissipating work surface when working with static sensitive devices. The kit is designed to connect the technician and the static dissipating work surface to the same ground point to prevent damage to the static sensitive devices by electrostatic discharge.

Use the static grounding wrist strap when installing and removing modules. Static discharge may damage static sensitive devices on modules in a cabinet. Use grounded equipment and static safe practices when working with static sensitive devices.

1. **Use Static Shielding Bag.** Keep the module in its static shielding bag until you are ready to install it in the system. Save the bag for future use.
2. **Ground Bags before Opening.** Before opening a bag containing an assembly with static sensitive devices, touch it to the equipment housing or ground to equalize charges.
3. **Avoid Touching Circuitry.** Handle assemblies by the edges; avoid touching the circuitry.
4. **Avoid Partial Connection of Static Sensitive Devices.** Verify that all devices connected to the modules are properly grounded before using them.
5. **Ground Test Equipment.**
6. **Use an Antistatic Field Service Vacuum.** Remove dust from the cards if necessary.
7. **Use a Grounded Wrist Strap.** Connect the wrist strap to the appropriate grounding plug.

8. **Do Not Use Lead Pencils to Set Dipswitches.** To avoid contamination of switch contacts that can result in unnecessary circuit board malfunction, do not use a lead pencil to set a dipswitch.

UNPACKING AND INSPECTION

1. Examine the hardware immediately to verify it has not been damaged in transit.
2. Notify the nearest Elsag Bailey Sales Office of any such damage.
3. File a claim for any damage with the transportation company that handled the shipment.
4. Use the original packing material and container to store the hardware.
5. Store the hardware in an environment of good air quality, free from temperature and moisture extremes.

SETUP/PHYSICAL INSTALLATION

Prior to installation, set the module S1 address switch. Configure the termination unit (TU) or termination module (TM) to output the digital signals from the DSO to the field devices. Refer to the appendices at the back of this instruction for configuration information.

NOTE: Due to the number of pins on the P3 connector, 12 outputs are separate while the remaining two pairs share output terminals. The positive (+) side of point 7 and 8 are tied together for each group (refer to Table 5-4).

Address Selection Switch (S1)

The DSO can have one of 64 addresses (address 0 to 63) on the I/O expander bus. This address uniquely identifies the I/O module to the control module and must be the same as the address set in the control module configuration (Function Code (FC) 83 specification S1).

The address is set by the eight position address dipswitch (S1) shown in Figure 3-1. The six right switch positions (3 through 8) of S1 set the six bit DSO address. Positions 1 and 2 are not used and must remain in the closed position (Fig. 3-2). Table 3-1 is a binary address conversion table for setting S1.

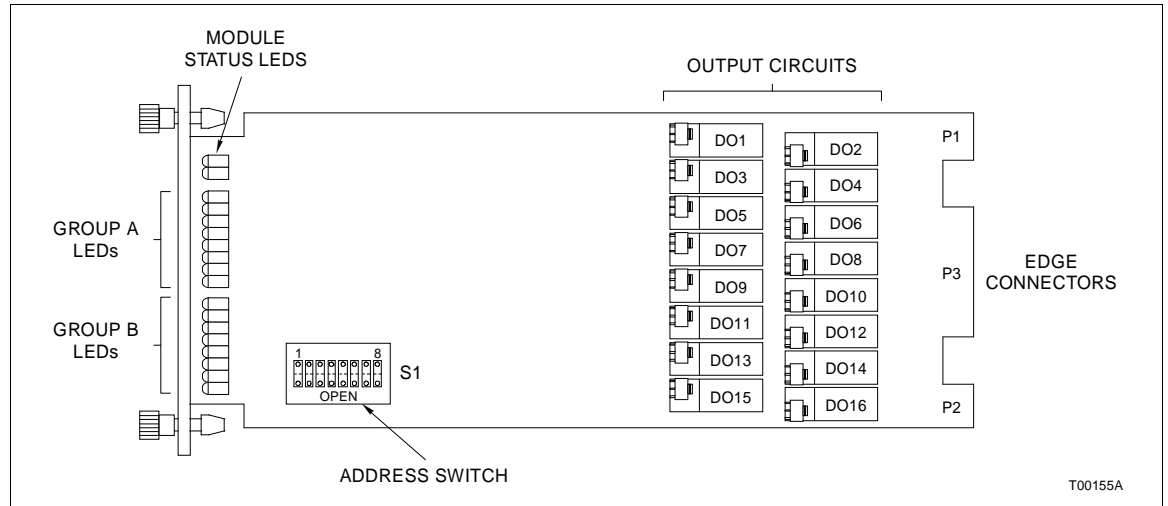

Figure 3-1. S1 Address Switch Location

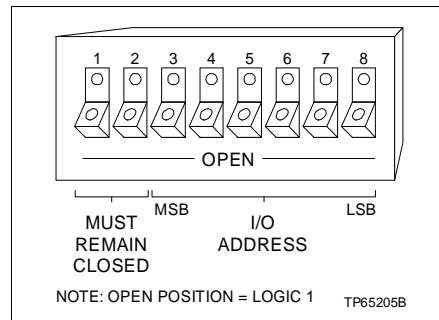

Figure 3-2. Address Switch S1 Settings

Table 3-1. S1 Address Switch Settings

ADDR	MSB						ADDR	LSB					
	3	4	5	6	7	8		3	4	5	6	7	8
0	0	0	0	0	0	0	14	0	0	1	1	1	0
1	0	0	0	0	0	1	15	0	0	1	1	1	1
2	0	0	0	0	1	0	16	0	1	0	0	0	0
3	0	0	0	0	1	1	17	0	1	0	0	0	1
4	0	0	0	1	0	0	18	0	1	0	0	1	0
5	0	0	0	1	0	1	19	0	1	0	0	1	1
6	0	0	0	1	1	0	20	0	1	0	1	0	0
7	0	0	0	1	1	1	21	0	1	0	1	0	1
8	0	0	1	0	0	0	22	0	1	0	1	1	0
9	0	0	1	0	0	1	23	0	1	0	1	1	1
10	0	0	1	0	1	0	24	0	1	1	0	0	0
11	0	0	1	0	1	1	25	0	1	1	0	0	1
12	0	0	1	1	0	0	26	0	1	1	0	1	0
13	0	0	1	1	0	1	27	0	1	1	0	1	1

Table 3-1. S1 Address Switch Settings (continued)

ADDR	MSB						LSB	ADDR	MSB						LSB
	3	4	5	6	7	8			3	4	5	6	7	8	
28	0	1	1	1	0	0	46	1	0	1	1	1	0		
29	0	1	1	1	0	1	47	1	0	1	1	1	1		
30	0	1	1	1	1	0	48	1	1	0	0	0	0		
31	0	1	1	1	1	1	49	1	1	0	0	0	1		
32	1	0	0	0	0	0	50	1	1	0	0	1	0		
33	1	0	0	0	0	1	51	1	1	0	0	1	1		
34	1	0	0	0	1	0	52	1	1	0	1	0	0		
35	1	0	0	0	1	1	53	1	1	0	1	0	1		
36	1	0	0	1	0	0	54	1	1	0	1	1	0		
37	1	0	0	1	0	1	55	1	1	0	1	1	1		
38	1	0	0	1	1	0	56	1	1	1	0	0	0		
39	1	0	0	1	1	1	57	1	1	1	0	0	1		
40	1	0	1	0	0	0	58	1	1	1	0	1	0		
41	1	0	1	0	0	1	59	1	1	1	0	1	1		
42	1	0	1	0	1	0	60	1	1	1	1	0	0		
43	1	0	1	0	1	1	61	1	1	1	1	0	1		
44	1	0	1	1	0	0	62	1	1	1	1	1	0		
45	1	0	1	1	0	1	63	1	1	1	1	1	1		

1 = OPEN; 0 = CLOSED

Termination Configuration

A termination unit (TU) or termination module (TM) connects the field device wiring to the INFI 90 OPEN system. The terminal blocks (connection points) are located on the TU or TM.

Configuration of the TU or TM is required to accept the digital field inputs sent to the DSI module. Refer to the appendices at the back of this instruction manual for complete information.

Physical Installation

NOTE: This installation section provides instructions pertaining to the physical installation of the digital output module only. For complete cable and termination information, refer to the applicable instruction manual (Table 1-2).

The DSO module inserts into a standard INFI 90 OPEN module mounting unit (MMU) and occupies one slot. To install:

1. Verify the slot assignment of the module.
2. Verify that a dipshunt is in the I/O expander bus socket on the MMU backplane between the I/O module and control module.

WARNING

Disconnect power before installing dipshunts on the MMU backplane. Failure to do so will result in contact with cabinet areas that could cause severe or fatal shock.

3. For TU or TM devices, connect the hooded end of the termination cable from the TU or TM to the MMU backplane. To do this, insert the connector into the backplane slot in the same slot as the one assigned to the digital output module. The latches should snap securely into place.
4. Align the digital output module with the guide rails in the MMU; gently slide the module in until the front panel is flush with the top and bottom of the MMU frame.
5. Push and turn the two captive retaining screws on the module faceplate one half turn to the latched position. It is latched when the slots on the screws are vertical and the open ends face the center of the module.

WIRING CONNECTIONS AND CABLING

The DSO has three card edge connectors to supply logic power, establish I/O expander bus communication and provide digital outputs (P1, P2, P3 respectively).

Wiring

Installing the module in the MMU connects the digital output module to the logic power (+5 VDC), necessary to drive the circuitry, at P1. It also connects P2 to the I/O expander bus for communication with the control module. P1 and P2 connections require no additional wiring or cabling.

NOTE: You must install a dipshunt on the backplane of the MMU to connect the I/O expander bus between the digital output module and the control module. Locate the modules so the bus can connect the modules or they will not communicate.

Cable Connections

The IMDSO14 digital output module can use either a NTDI01 or NTDO02 termination unit or a NIDI01 termination module for termination. Refer to Figure 3-3 to determine the cables to use with the NTDI01 and the NIDI01. Refer to Figure 3-4 to determine cables to use with the NTDO02 termination unit.

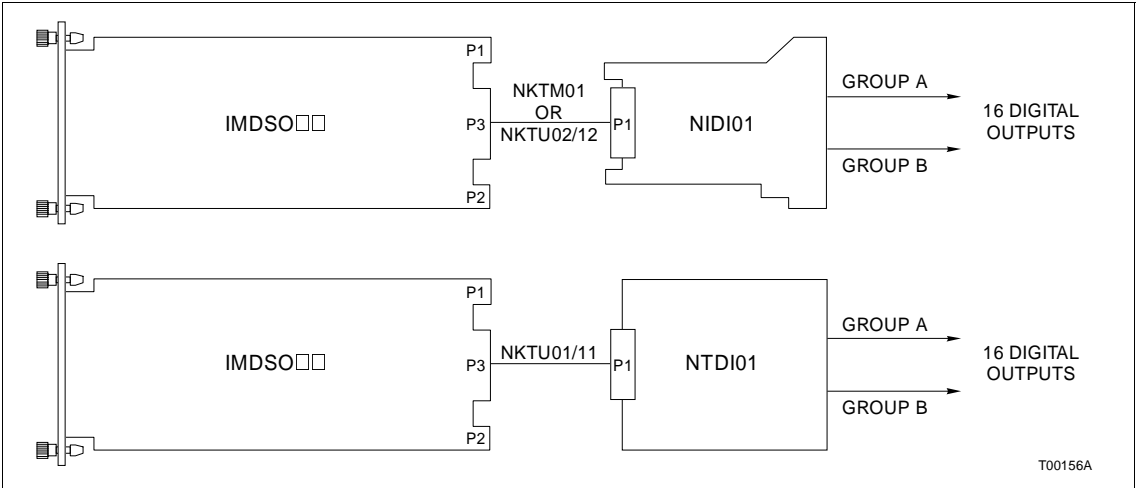

Figure 3-3. NIDI01 and NTDI01 Cable Connections and Terminations

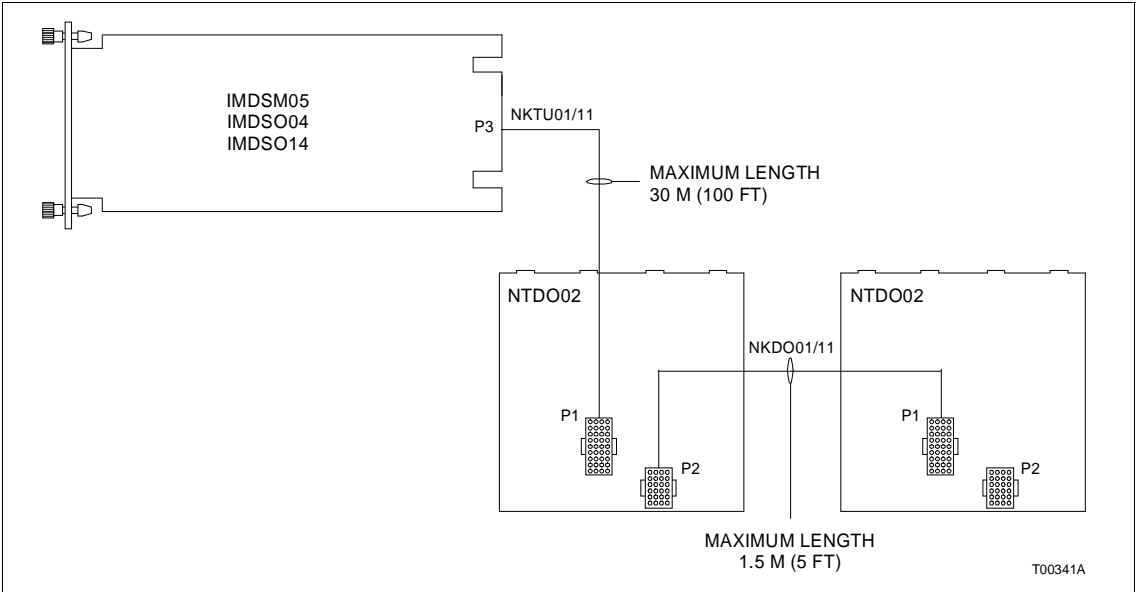

Figure 3-4. NTDO02 Cable Connections and Terminations

FUSING

The IMDSO14 digital output module does not have any on board fusing requirements.

PREOPERATING ADJUSTMENTS

The IMDSO14 digital output module does not require any adjustments prior to operation.

SECTION 4 - OPERATING PROCEDURES

INTRODUCTION

This section explains the front panel indicators and start-up procedures for the IMDSO14 Digital Output module.

STATUS INDICATORS

The DSO module has two front panel module status LED indicators to aid in system test and diagnosis. Sixteen front panel indicators display the output states (ON or OFF). The location of the indicators is shown in Figure 4-1.

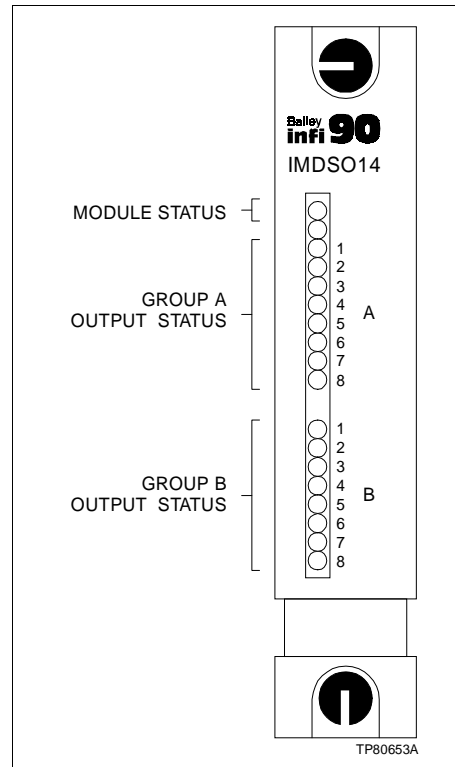

Figure 4-1. Front Panel Indicators

Module Status Indicators

Table 4-1 describes the states of the module status LED indicators (refer to **TROUBLESHOOTING** in Section 5 to determine corrective actions).

Table 4-1. Status LED Indicators

Red LED	Green LED	Indication
OFF	OFF	No power or not enabled.
OFF	ON	Enabled and communicating with control module.
ON	OFF	Bus fault timer error (time-out)
ON	ON	Not allowed.

Output Status Indicators

There are 16 front panel indicators (group A and group B) to display the output states. Each indicator represents one digital output. A red LED indicates an energized (ON) output; a blank LED indicates a non-energized (OFF) output.

START-UP PROCEDURES

The control module controls the start-up of the DSO module; it is fully automatic. Function Code (FC) 83 in the control module configuration enables the DSO. Specification S1 (FC 83) is the module address. It must be the same as the address set on the module S1 address dipswitch. The front panel LEDs (green solid, red off) verifies that the module is enabled and communicating.

SECTION 5 - TROUBLESHOOTING

INTRODUCTION

This section explains the error indications and corrective actions for the IMDSO14 Digital Output (DSO) module.

ERROR INDICATIONS AND CORRECTIVE ACTION

You can obtain the status of the DSO module through an INFI 90 OPEN operator interface (e.g., Operator Interface Station, Engineering Work Station, Configuration and Tuning Terminal) or the front panel status LED indicators.

NOTE: If you look at the DSO module front panel output status LED indicators and none are lit, this may indicate a faulty DSO (an output must be energized to light an LED). Check the control module for bad quality on its output blocks.

Module Status LEDs

The two front panel status LEDs have three states to indicate normal operation and error conditions. Table 5-1 lists DSO status LED states, error indications, probable causes and corrective actions.

NOTE: If the corrective actions in Table 5-1 do not correct a problem with the DSO module, replace it.

Table 5-1. Status LED Indications and Corrective Actions

LED State	Indication	Probable Cause	Corrective Action
Green ON Red OFF	Digital output module operating normally and communicating with control module	Normal operation	No action required
Green OFF Red OFF	Digital output module not enabled	Address set on switch S1 not the same as address in control module configuration FC 83, S1	Change address on S1 switch to match FC 83, S1 OR Change address in FC 83, S1 to match S1 switch setting
		Dipshunt not properly installed between control module and digital output module	Verify dipshunt is installed properly (no bent pins) in I/O expander bus socket on MMU backplane between control and digital output module
		Control module configuration is not correct	Verify FC 83 is in control module configuration
	No power to digital output module	Module not completely inserted in MMU	Verify module is completely inserted in MMU: faceplate flush with MMU and captive retaining screws latched

Table 5-1. Status LED Indications and Corrective Actions (continued)

LED State	Indication	Probable Cause	Corrective Action
Red ON Green OFF	Bus fault timer error (<i>time-out</i>)	I/O expander bus clock failure	Check control module for proper operation
		Dipshunt not installed between control module and digital output module	Verify dipshunt is installed in the I/O expander bus socket on the MMU backplane between control module and digital output module

Control Module Errors

The control module performs status checks on the DSO module. An error will appear in the report function of an operator interface. Refer to the Product Instruction for the operator interface being used (Table 1-2) for an explanation of these reports.

Function Code (FC) 83 output block N in the control module configuration is the DSO status flag (logic 0=good; logic 1=bad). You can use an operator interface to monitor this block. If the status flag is a logic 1, check the front panel module status LEDs and the operator interface report function to determine corrective actions.

NOTE: If FC 83 specification S3 is set to 0, the control module will *trip* when the DSO module fails. Changing specification S3 to a 1 allows the control module to continue to operate if any DSO error condition exists.

The address set on address switch S1 and in the control module configuration must be the same. The control module generates a **MISSING SLAVE MODULE** if they do not match. Verify that the address set on switch S1 is the same as the address in FC 83 specification S1. If not:

CAUTION

Disable the output signals before removing the module to prevent damage to the edge connector pins.

1. Remove the module and change the setting of address switch S1 to correspond with the control module configuration (refer to **INSTALLATION** in Section 3 for the procedures to set an address and to install a digital output module).

OR

2. Modify the address in the control module configuration (FC 83 specification S1) to correspond with the address set on address switch S1 of the digital output module. Use an INFI 90 OPEN operator interface to modify the configuration. For procedures on how to modify a function code specification, refer to the applicable instruction manual for the operator interface being used.

WARNING

Disconnect power before installing dipshunts on the MMU backplane. Failure to do so will result in contact with cabinet areas that could cause severe or fatal shock.

The control module generates a **MISSING SLAVE MODULE** error if the I/O expander bus is not connected between it and the digital output module. Verify the bus connection on the MMU backplane.

If the I/O module is faulty, replace it with a new one. Refer to the **REPAIR/REPLACEMENT PROCEDURES** in Section 7 for procedures to replace a DSO module.

MODULE PIN CONNECTIONS

The digital output module has three connection points for external signals and power (P1, P2 and P3). Tables 5-2, 5-3 and 5-4 show the pin connections.

*Table 5-2. P1 Power
Pin Connections*

Pin (P1)	Connection
1	+5 VDC
2	+5 VDC
3	NC
4	NC
5	COMMON
6	COMMON
7	NC
8	NC
9	PFI
10	PFI
11	NC
12	NC

NC = Not connected
PFI = Power fail interrupt

Table 5-3. P2 Expander Bus Connections

Pin (P2)	Signal
1	Data 1
2	Data 0
3	Data 3
4	Data 2
5	Data 5
6	Data 4
7	Data 7
8	Data 6
9	Clock
10	Sync
11	NC
12	NC

NC = Not connected

Table 5-4. P3 Input Signal Pin Connections

Group A			Group B		
Digital Output	Pin (+)	Pin (-)	Digital Output	Pin (+)	Pin (-)
1	A	1	1	K	9
2	B	2	2	L	10
3	C	3	3	M	11
4	D	4	4	N	12
5	E	5	5	P	13
6	F	6	6	R	14
7	H ¹	7	7	S ¹	15
8	H	J	8	S	8

NOTE:

1. Shared pin (outputs 7 and 8)

SECTION 6 - MAINTENANCE

INTRODUCTION

The reliability of any stand-alone product or control system is affected by the maintenance of the equipment. Elsasg Bailey recommends that all equipment users practice a preventive maintenance program that will keep the equipment operating at an optimum level.

This section presents procedures that the customer should be able to perform on site. These preventive maintenance procedures should be used as a guideline to assist in establishing good preventive maintenance practices.

Personnel performing preventive maintenance should meet the following qualifications.

- Maintenance personnel should be qualified electrical technicians or engineers that know the proper use of test equipment.
- Maintenance personnel should be familiar with the module mounting unit, have experience working with process control systems, and know what precautions to take when working on live AC and/or DC systems.

PREVENTIVE MAINTENANCE SCHEDULE

Table 6-1 is the preventive maintenance schedule for the IMDSO14 digital output module. The table lists the preventive maintenance tasks in groups according to their specified maintenance interval. Instructions for tasks that require further explanation are covered under **PREVENTIVE MAINTENANCE PROCEDURES**.

NOTE: The preventive maintenance schedule is for general purposes only. Your application may require special attention.

EQUIPMENT AND TOOLS REQUIRED

Tools and equipment required for maintenance procedures are:

- Antistatic vacuum.
- Screwdriver (medium length).
- Isopryl alcohol (99.5 percent electronic grade).
- Distilled water.
- Compressed air.
- Foam tipped swabs.
- Lint free cloths.
- Eberhard Faber (400A) pink pearl eraser.

Table 6-1. Preventive Maintenance Schedule

Task	Frequency
Check cabinet, module mounting unit backplane assembly, digital output module and termination device for dust. Clean as necessary using an antistatic vacuum. If circuit board cleaning is necessary, refer to procedure.	Every six months or during plant shut-down, whichever occurs first.
Check all signal, power and ground connections that are associated with the digital output module. Verify that they are secure. Refer to procedure.	

PREVENTIVE MAINTENANCE PROCEDURES

This section covers tasks from Table 6-1 that require specific instructions or further explanation.

- Cleaning printed circuit boards and edge connectors.
- Checking signal, power and ground connections.

Printed Circuit Board Cleaning

There are several circuit board cleaning procedures in this section. These procedures cover circuit board cleaning and washing, cleaning edge connectors and circuit board laminate between edge connectors. Use the procedures that meet the needs of each circuit board. Remove all dust, dirt, oil, corrosion or any other contaminant from the circuit board.

Do all cleaning and handling of the printed circuit boards at static safe work stations. Always observe the steps under **SPECIAL HANDLING** in Section 3 when handling printed circuit boards.

WARNING	<p>Never clean electrical parts or components with live power present. Doing so exposes you to an electrical shock hazard.</p> <p>Wear eye protection whenever working with cleaning solvents. When removing solvents from printed circuit boards using compressed air, injury to the eyes could result from splashing solvent as it is removed from the printed circuit board.</p>
----------------	---------------------------------------------------------------------------------------------------------------------------------------------------------------------------------------------------------------------------------------------------------------------------------------------------------------------------------------------------------------------------------------------------

GENERAL CLEANING AND WASHING

If the printed circuit board needs minor cleaning, remove dust and residue from the printed circuit board surface using clean, dry, filtered compressed air or an antistatic field service vacuum cleaner.

To wash the printed circuit board:

1. Clean the printed circuit board by spraying or wiping it with isopropyl alcohol (99.5% electronic grade). Use a foam tipped swab to wipe the circuit board.
2. Remove excess solvent by using compressed air to blow it free of the circuit board.

EDGE CONNECTOR CLEANING

1. Use a solvent mixture of 80% isopropyl alcohol (99.5% electronic grade) and 20% distilled water.
2. Soak a lint free cloth with the solvent mixture.
3. Work the cloth back and forth parallel to the edge connector contacts.
4. Repeat with a clean cloth that is soaked with the solvent mixture.
5. Dry the edge connector contact area by wiping with a clean lint free cloth.

To clean tarnished or deeply stained edge connector contacts:

1. Use an Eberhard Faber (400A) pink pearl eraser or equivalent to remove tarnish or stains. Fiberglass or nylon burnishing brushes may also be used.
2. Minimize electrostatic discharge by using the 80/20 isopropyl alcohol/water solution during burnishing.
3. Do not use excessive force while burnishing. Use only enough force to shine the contact surface. Inspect the edge connector after cleaning to assure no loss of contact surface.
4. Wipe clean with a lint free cloth.

Checking Connections

NOTE: Power to the cabinet should be off while performing this preventive maintenance task.

WARNING

There are exposed AC and DC connections inside the cabinet. These exposed electrical connections present a shock hazard that can cause injury or death.

If input or output circuits are a shock hazard after disconnecting system power at the power entry panel, then the door of the cabinet containing these externally powered circuits must be marked with a warning stating that multiple power sources exist.

Check all signal wiring, power and ground connections within the cabinet to verify their integrity. When checking connections, always turn a screw, nut or other fastening device in the direction to tighten only. If the connection is loose, it will be tightened. If the connection is tight, the tightening action will verify that it is secure. There must not be any motion done to loosen the connection.

1. Verify that all power connections within the cabinet are secure.
2. Verify that all wiring connections to the termination unit, or termination module are secure.

SECTION 7 - REPAIR/REPLACEMENT PROCEDURES

INTRODUCTION

This section explains the replacement procedures for the IMDSO14 Digital Output (DSO) module. There are no special tools required to replace a DSO module.

MODULE REPAIR/REPLACEMENT

If the DSO is faulty, replace it with a new one. **DO NOT** try to repair the module; replacing components may affect the module performance. You can remove the module while system power is supplied. To replace a module.

1. Push and turn the two front panel captive retaining screws one-half turn to unlatch the module. It is unlatched when the slots on the screws are vertical and the open end of the slots face away from the module.
2. Gently slide the module out of the MMU.
3. Configure the replacement module switch settings. Ensure they are set the same as the original module.
4. In the same slot assignment as the original module, align the replacement module with the guide rails in the MMU; gently slide it in until the front panel is flush with the top and bottom of the MMU frame.
5. Push and turn the two captive retaining screws on the module faceplate one half turn to the latched position. It is latched when the slots on the screws are vertical and the open ends face the center of the module.
6. Return to normal operation.

SECTION 8 - SUPPORT SERVICES

INTRODUCTION

Elsag Bailey Process Automation is ready to help in the use and repair of its products. Contact the nearest sales office to make requests for sales, applications, installation, repair, overhaul and maintenance contract services.

REPLACEMENT PARTS AND ORDERING INFORMATION

When making repairs at your facility, order replacement parts from a Elsag Bailey Process Automation sales office. Provide the following information.

1. Part description, part number and quantity.
2. Model and serial number (if applicable).
3. Elsag Bailey instruction number and page number of part reference.

TRAINING

Elsag Bailey Process Automation has a modern training facility available for training your personnel. On-site training is also available. Contact a Elsag Bailey sales office for specific information and scheduling.

TECHNICAL DOCUMENTATION

Additional copies of this instruction, or other Elsag Bailey Process Automation instructions, can be obtained from the nearest Elsag Bailey sales office at a reasonable charge.

APPENDIX A - TERMINATION UNIT (NTDI01) CONFIGURATION

INTRODUCTION

The IMDSO14 digital output module can use a NTDI01 termination unit for termination. Dipshunts on the NTDI01 unit configure the digital outputs that are sent to the process. The digital output module (DSO) outputs switch voltages of 24 VDC at 250 milliamps or 48 VDC at 125 milliamps.

Figure A-1 shows the NTDI01 dipshunt without strapping, and the digital signal path from the DSO module to the field device for a termination unit application. Refer to Table A-1 to determine the dipshunt strapping to configure your application. Figure A-2 shows the terminal assignments for the digital output signals. Refer to this figure when connecting field wiring to the NTDI01. Refer to the NTDI01 instruction manual (Table 1-2) for complete termination unit information.

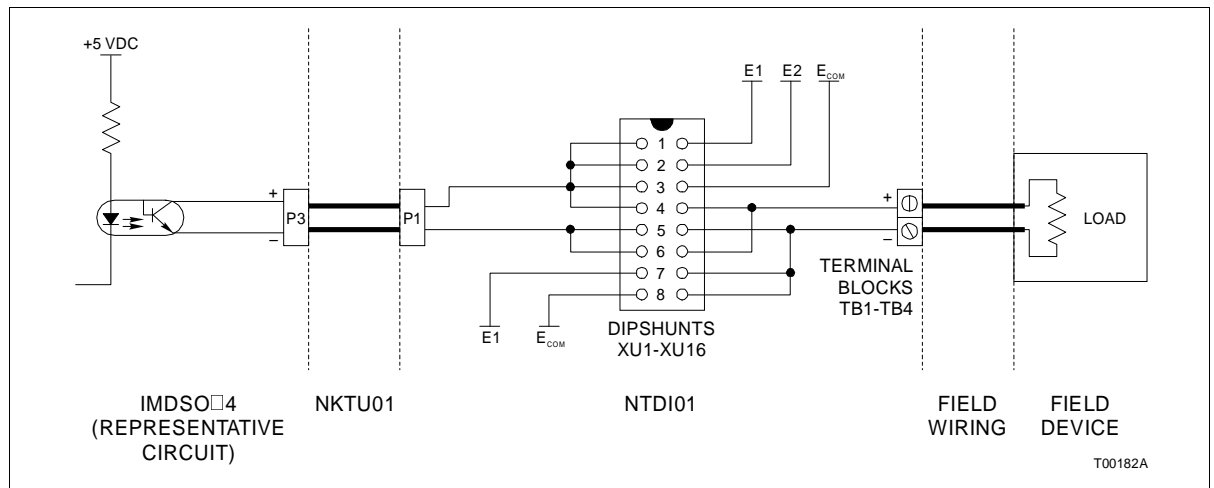
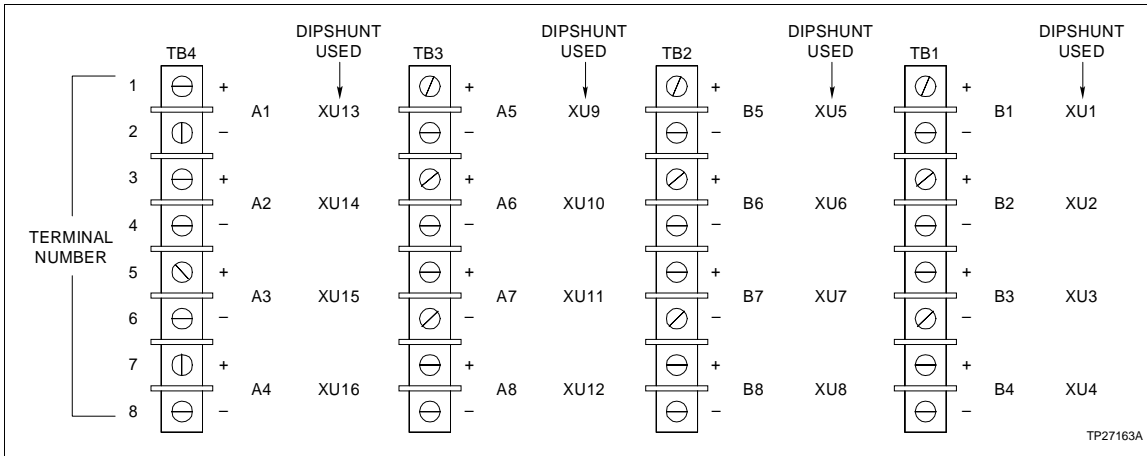

Figure A-1. NTDI01 Dipshunts

Table A-1. NTDI01 Dipshunt Configuration

Application/Signal Type	Dipshunt Configuration
Field powered contact	
System powered from E1, 24 VDC or 48 VDC	
System powered from E2, 24 VDC or 48 VDC	

TP27139A



TP27163A

Figure A-2. NTDI01 Terminal Assignments

APPENDIX B - TERMINATION MODULE (NIDI01) CONFIGURATION

INTRODUCTION

The IMDSO14 digital output module can use a NIDI01 termination module for termination. Jumpers on the termination module configure the digital outputs that are sent to the process. The DSO module outputs switch voltages of 24 VDC at 250 milliamps or 48 VDC at 125 milliamps. Refer to Table B-1 to determine the jumper setting to configure your application. Figure B-1 shows the terminal assignments for the digital output signals. Refer to this figure when connecting field wiring to the NIDI01. Refer to the NIDI01 instruction manual (Table 1-2) for complete termination module information.

Table B-1. NIDI01 Jumper Configuration

Application/ Signal Type	Jumper Configuration J1 - J10
24 VDC, 48 VDC	<div style="display: flex; justify-content: center; align-items: center;"> <div style="margin-right: 20px;">1</div> <div style="margin-right: 20px;">2</div> <div style="margin-right: 20px;">3</div> <div style="margin-right: 20px;">4</div> <div style="margin-right: 20px;">5</div> <div style="margin-right: 20px;">6</div> <div style="margin-right: 20px;">7</div> <div style="margin-right: 20px;">8</div> <div style="margin-right: 20px;">9</div> <div style="margin-right: 20px;">10</div> </div>

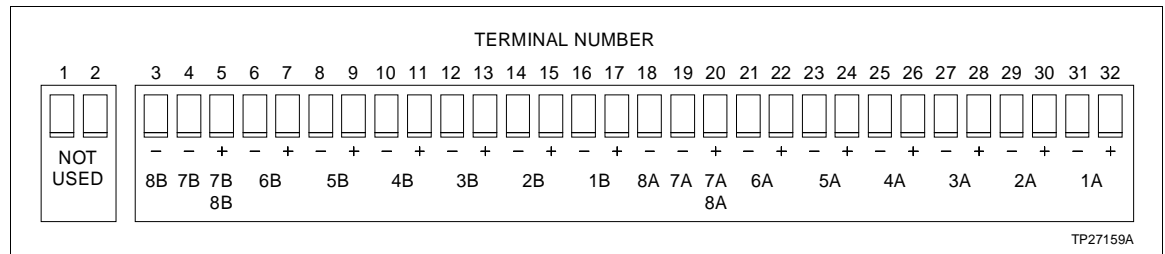

Figure B-1. NIDI01 Terminal Assignments

APPENDIX C - TERMINATION UNIT (NTDO02) CONFIGURATION

INTRODUCTION

The IMDSO14 digital output module can use a NTDO02 for termination. The termination unit can provide up to eight solid state relay outputs. Dipshunts on the termination unit configure the I/O. Figure C-1 shows the NTDO02 configuration sockets (dipshunts). Refer to this figure when connecting field wiring to the NTDO02 termination unit. Refer to Tables C-1 and C-2 to determine the dipshunt strapping. Refer to the NTDO02 instruction manual (Table 1-2) for complete termination unit information.

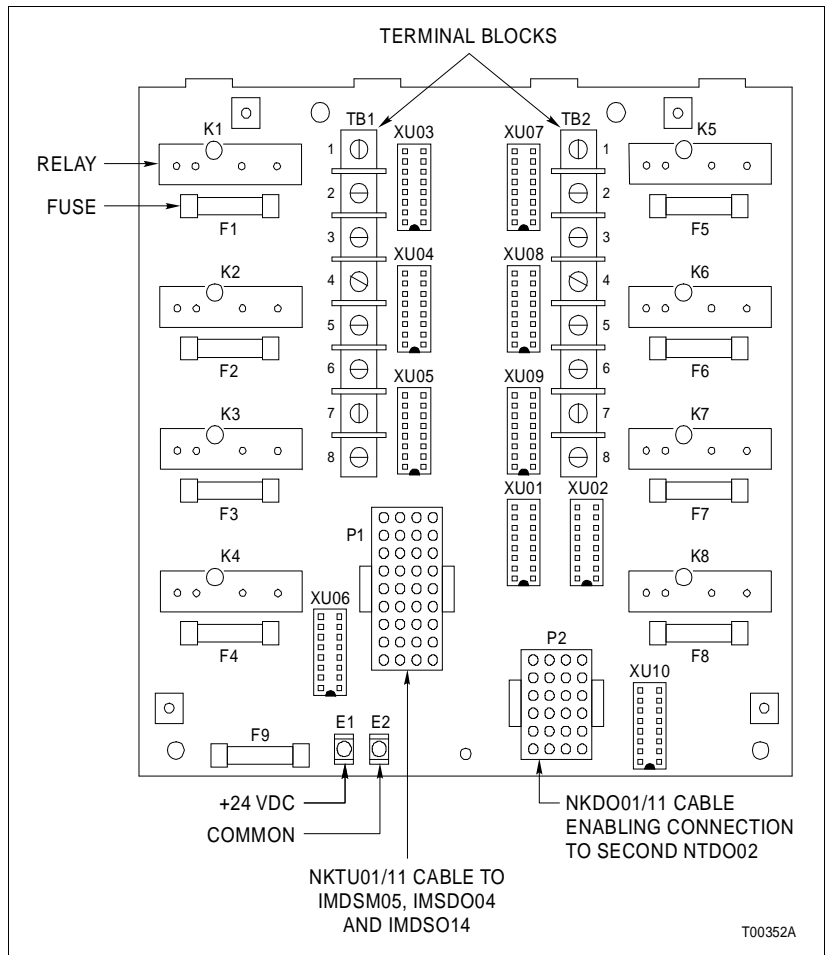

Figure C-1. NTDO02 Termination Unit

Dipshunt Configuration

There are ten dipshunts on the termination unit. Figure C-1 shows the locations of the dipshunts. Dipshunts XU01 and XU02 determine the I/O module relay control. Configure a dipshunt by either cutting straps or leaving straps uncut in certain sequences. Cut the dipshunt straps using a standard shunt cutting tool. Always cut straps completely. Install the configured dipshunt into the desired socket on the termination unit. To install a dipshunt, align the end of the dipshunt identified with the silver dot to the end of the socket having an identification mark and push the dipshunt into the socket. Be careful not to bend any pins during insertion.

NORMAL OPERATION (XU01 AND XU02)

Normally each I/O module output controls one relay on the termination unit. The IMDSO14 I/O module has 16 outputs divided into two groups. Outputs one through eight belong to group A and outputs nine through 16 belong to group B. Group A controls outputs one through eight on a termination unit connected to the I/O module. The termination unit can be interconnected to a second termination unit. Group B controls the second termination unit. Table C-1 shows the settings for dipshunts XU01 and XU02 for normal operation.

NOTE: To control the termination unit using I/O module group A (one through eight) outputs, install dipshunt XU01. To control the termination unit using I/O module group B (nine through 16) outputs, install dipshunt XU02. Do not install both dipshunts (XU01 and XU02) on the same termination unit.

Table C-1. NTDO02 Dipshunt XU01 and XU02 Normal Operation Settings

Strap Numbers XU01 1 2 3 4 5 6 7 8	Strap Numbers XU02 1 2 3 4 5 6 7 8	Function
1 1 1 1 1 1 1 1	0 0 0 0 0 0 0 0	Normal operation dipshunt setting. I/O module group A (outputs 1 - 8) control termination unit outputs 1 - 8.
0 0 0 0 0 0 0 0	1 1 1 1 1 1 1 1	Normal operation dipshunt setting. I/O module group B (outputs 9 - 16) control termination unit outputs 1 - 8.

NOTE: 0 = open or cut strap, 1 = intact or shorted strap.

ADVANCED APPLICATIONS (XU01 AND XU02)

In advanced applications, a single output from the IMDSO14 digital output module can control up to nine relays. Each I/O module can control up to 18 interconnected termination units. Figure C-2 shows the internal circuitry of dipshunt sockets XU01 and XU02.

There are two ways to configure the NTDO02 termination unit. Use either dipshunts or insert an adapter plug (part number

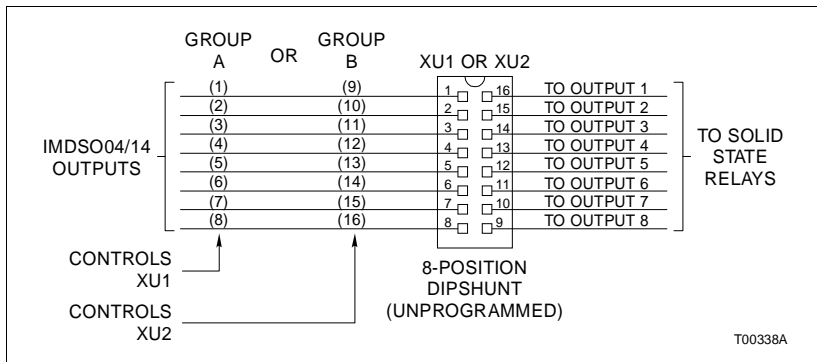

Figure C-2. NTDO02 Dipshunt Socket XU01 and XU02 Internal Circuitry

1947690□16) into the dipshunt socket. Figures C-3 and C-4 show two configuration examples. Figure C-3 shows an I/O module with each output controlling a relay. Figure C-4 shows an example of an I/O module controlling 27 relays via four termination units using adapter plugs. In the example shown in Figure C-4:

- I/O module output one (group A) controls nine relays.
- I/O module output two (group A) controls three relays.
- I/O module output ten (group B) controls eight relays.
- I/O module output eleven (group B) controls seven relays.

When using the adapter plugs, jumper the I/O module outputs to the appropriate relays by soldering wire (22 to 30 gage) on the adapter plug and then inserting the adapter plug into the dipshunt socket (XU01 or XU02)..

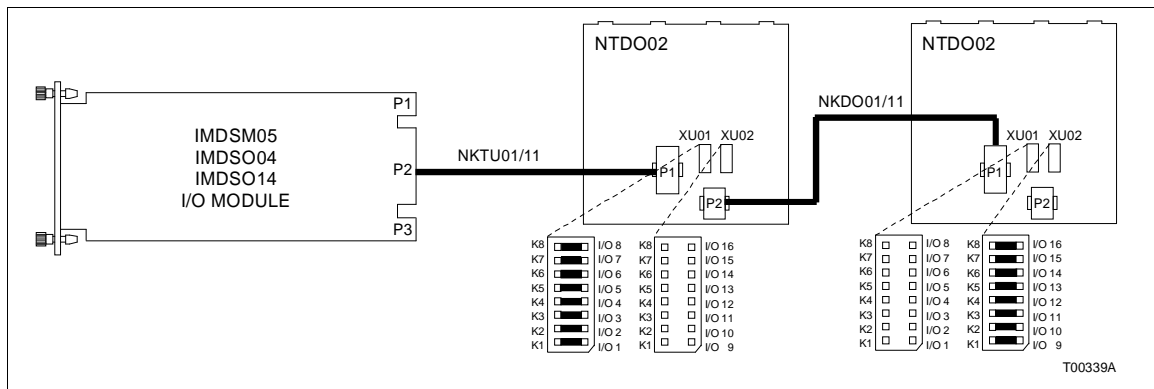

Figure C-3. NTDO02 Example Configuration Using Dipshunts

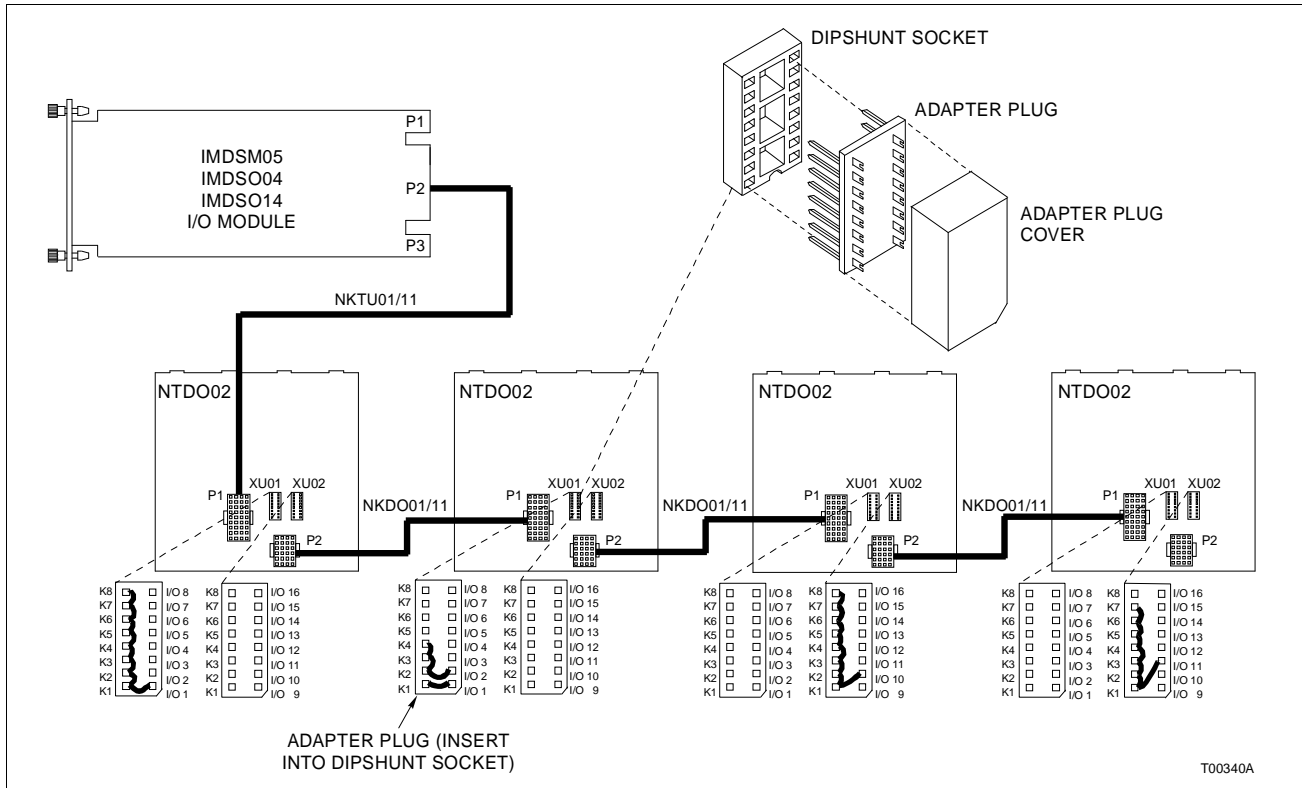

Figure C-4. NTDO02 Example Configuration Using Adapter Plugs

I/O MODULE SELECTION (XU03 THROUGH XU10)

Dipshunts XU03 through XU10 determine the type of I/O module used. Dipshunts XU03 through XU10 must be configured identically for each relay being used on all termination units connected to a particular I/O module. Table C-2 shows the settings for dipshunts XU03 through XU10 for the IMDSO14 module.

NOTE: To use any output on interconnected termination units, the corresponding dipshunt must be configured and installed on all preceding interconnected termination units. For example, if there are three interconnected termination units, XU09 on all three termination units must have a configured dipshunt installed to use output seven on the last interconnected termination unit.

Install a configured dipshunt in XU09 and XU10 to use output eight on any NTDO02 termination unit. Configuring XU09 connects 24 VDC to XU10.

Terminal Block Wiring

See Figure C-5 for terminal block assignments and terminal polarity. Field wiring requirements will depend on the application. Connect the wiring from the terminals to the output devices. Proper wiring polarity is required for relay signals.

Table C-2. NTDO02 Dipshunt XU03 through XU10 Settings

Strap Number	Function
1 2 3 4 5 6 7 8	
1 0 0 1 0 1 1 1	Termination unit is controlled by IMDSO14 I/O module.

NOTE: 0 = open or cut strap, 1 = intact or shorted strap.

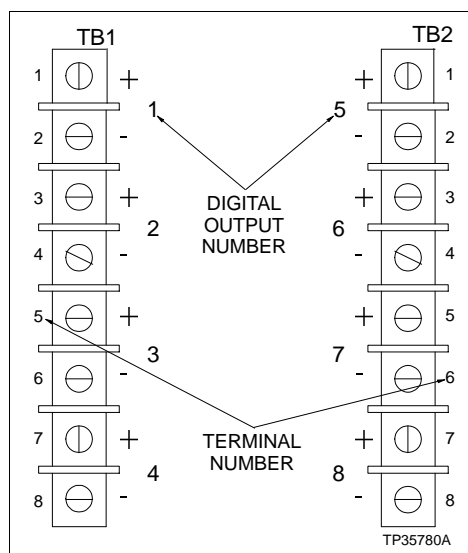

Figure C-5. NTDO02 Terminal Assignments

APPENDIX D - QUICK REFERENCE INFORMATION

INTRODUCTION

This section provides a source for reference information. It contains the switch location for the IMDSO14 digital output module. Refer to **INSTALLATION** in Section 3 for a complete description of switch settings.

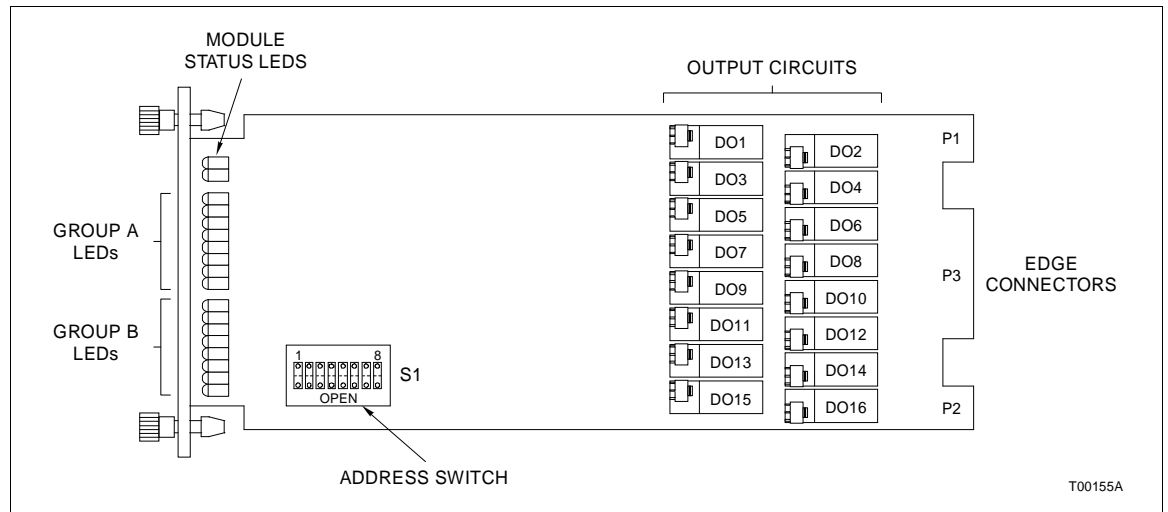

Figure D-1. S1 Address Switch Location

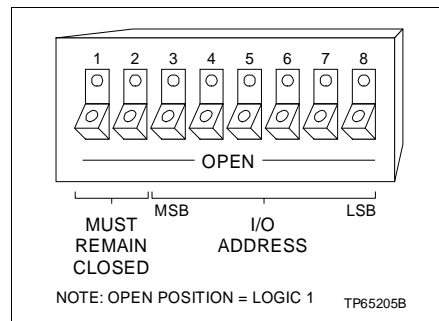

Figure D-2. S1 Address Switch

Table D-1. S1 Address Switch Settings

ADDR	MSB						LSB	ADDR	MSB						LSB
	3	4	5	6	7	8			3	4	5	6	7	8	
0	0	0	0	0	0	0	0	32	1	0	0	0	0	0	0
1	0	0	0	0	0	0	1	33	1	0	0	0	0	0	1
2	0	0	0	0	0	1	0	34	1	0	0	0	1	0	0
3	0	0	0	0	0	1	1	35	1	0	0	0	1	1	0
4	0	0	0	1	0	0	0	36	1	0	0	1	0	0	0
5	0	0	0	1	0	0	1	37	1	0	0	1	0	0	1
6	0	0	0	1	1	0	0	38	1	0	0	1	1	0	0
7	0	0	0	1	1	1	1	39	1	0	0	1	1	1	0
8	0	0	1	0	0	0	0	40	1	0	1	0	0	0	0
9	0	0	1	0	0	0	1	41	1	0	1	0	0	0	1
10	0	0	1	0	1	0	0	42	1	0	1	0	1	0	0
11	0	0	1	0	1	1	1	43	1	0	1	0	1	1	0
12	0	0	1	1	0	0	0	44	1	0	1	1	0	0	0
13	0	0	1	1	0	0	1	45	1	0	1	1	0	0	1
14	0	0	1	1	1	0	0	46	1	0	1	1	1	0	0
15	0	0	1	1	1	1	1	47	1	0	1	1	1	1	0
16	0	1	0	0	0	0	0	48	1	1	0	0	0	0	0
17	0	1	0	0	0	0	1	49	1	1	0	0	0	0	1
18	0	1	0	0	1	0	0	50	1	1	0	0	1	0	0
19	0	1	0	0	1	1	1	51	1	1	0	0	1	1	0
20	0	1	0	1	0	0	0	52	1	1	0	1	0	0	0
21	0	1	0	1	0	0	1	53	1	1	0	1	0	0	1
22	0	1	0	1	1	0	0	54	1	1	0	1	1	0	0
23	0	1	0	1	1	1	1	55	1	1	0	1	1	1	0
24	0	1	1	0	0	0	0	56	1	1	1	0	0	0	0
25	0	1	1	0	0	0	1	57	1	1	1	0	0	0	1
26	0	1	1	0	1	0	0	58	1	1	1	0	1	0	0
27	0	1	1	0	1	1	1	59	1	1	1	0	1	1	0
28	0	1	1	1	0	0	0	60	1	1	1	1	0	0	0
29	0	1	1	1	0	0	1	61	1	1	1	1	0	0	1
30	0	1	1	1	1	0	0	62	1	1	1	1	1	0	0
31	0	1	1	1	1	1	1	63	1	1	1	1	1	1	0

1 = OPEN; 0 = CLOSED