

E96-416

Bailey®
infi 90

Instruction

Analog Input Termination Unit (NTAI05)

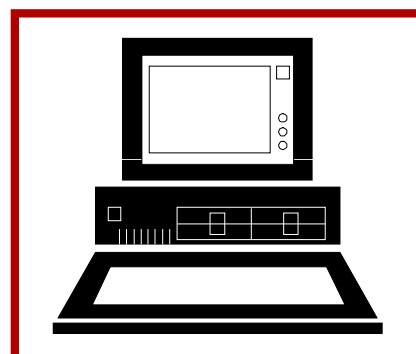
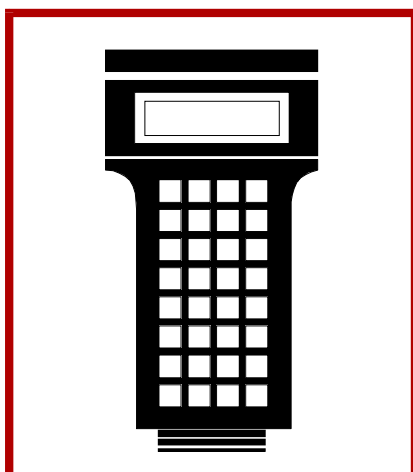
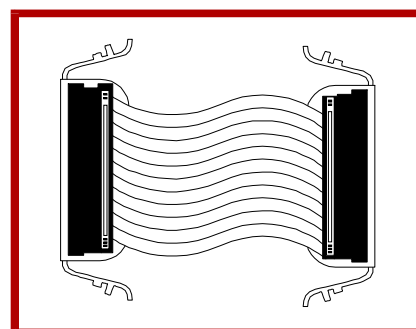
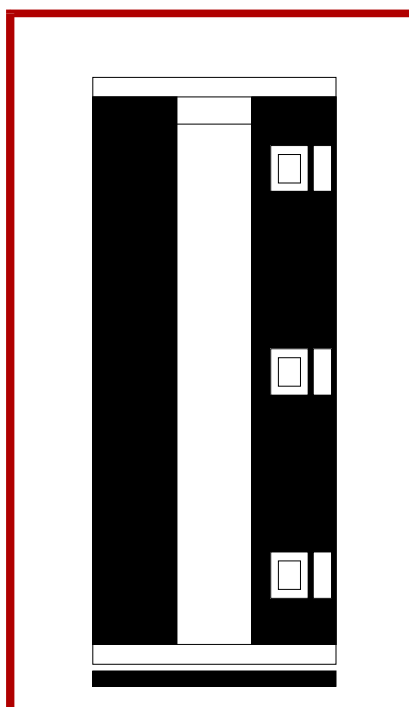
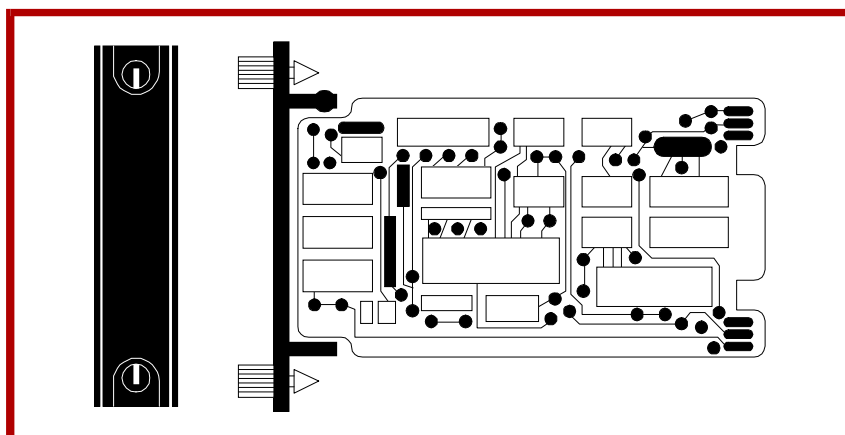
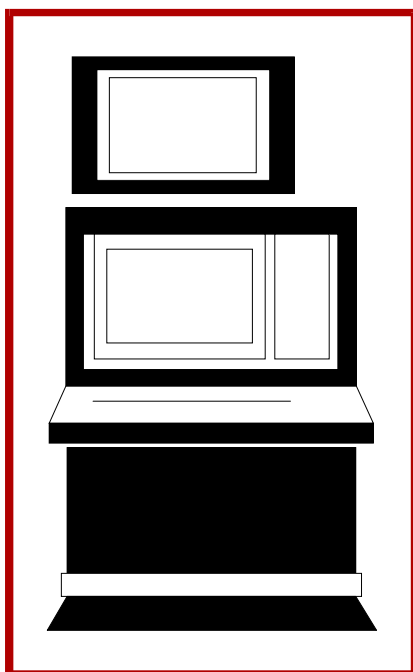

WARNING notices as used in this instruction apply to hazards or unsafe practices that could result in personal injury or death.

CAUTION notices apply to hazards or unsafe practices that could result in property damage.

NOTES highlight procedures and contain information that assists the operator in understanding the information contained in this instruction.

WARNING

INSTRUCTION MANUALS

DO NOT INSTALL, MAINTAIN, OR OPERATE THIS EQUIPMENT WITHOUT READING, UNDERSTANDING, AND FOLLOWING THE PROPER **Elsag Bailey** INSTRUCTIONS AND MANUALS; OTHERWISE, INJURY OR DAMAGE MAY RESULT.

RADIO FREQUENCY INTERFERENCE

MOST ELECTRONIC EQUIPMENT IS INFLUENCED BY RADIO FREQUENCY INTERFERENCE (RFI). CAUTION SHOULD BE EXERCISED WITH REGARD TO THE USE OF PORTABLE COMMUNICATIONS EQUIPMENT IN THE AREA AROUND SUCH EQUIPMENT. PRUDENT PRACTICE DICTATES THAT SIGNS SHOULD BE POSTED IN THE VICINITY OF THE EQUIPMENT CAUTIONING AGAINST THE USE OF PORTABLE COMMUNICATIONS EQUIPMENT.

POSSIBLE PROCESS UPSETS

MAINTENANCE MUST BE PERFORMED ONLY BY QUALIFIED PERSONNEL AND ONLY AFTER SECURING EQUIPMENT CONTROLLED BY THIS PRODUCT. ADJUSTING OR REMOVING THIS PRODUCT WHILE IT IS IN THE SYSTEM MAY UPSET THE PROCESS BEING CONTROLLED. SOME PROCESS UPSETS MAY CAUSE INJURY OR DAMAGE.

AVERTISSEMENT

MANUELS D'OPÉRATION

NE PAS METTRE EN PLACE, RÉPARER OU FAIRE FONCTIONNER L'ÉQUIPEMENT SANS AVOIR LU, COMPRIS ET SUIVI LES INSTRUCTIONS RÉGLEMENTAIRES DE **Elsag Bailey**. TOUTE NÉGLIGENCE À CET ÉGARD POURRAIT ÊTRE UNE CAUSE D'ACCIDENT OU DE DÉFAILLANCE DU MATÉRIEL.

PERTURBATIONS PAR FRÉQUENCE RADIO

LA PLUPART DES ÉQUIPEMENTS ÉLECTRONIQUES SONT SENSIBLES AUX PERTURBATIONS PAR FRÉQUENCE RADIO. DES PRÉCAUTIONS DEVRONT ÊTRE PRISES LORS DE L'UTILISATION DU MATÉRIEL DE COMMUNICATION PORTATIF. LA PRUDENCE EXIGE QUE LES PRÉCAUTIONS À PRENDRE DANS CE CAS SOIENT SIGNALÉES AUX ENDROITS VOULUS DANS VOTRE USINE.

PERTURBATIONS DU PROCÉDÉ

L'ENTRETIEN DOIT ÊTRE ASSURÉ PAR UNE PERSONNE QUALIFIÉE EN CONSIDÉRANT L'ASPECT SÉCURITAIRE DES ÉQUIPEMENTS CONTRÔLÉS PAR CE PRODUIT. L'AJUSTEMENT ET/OU L'EXTRACTION DE CE PRODUIT PEUT OCCASIONNER DES À-COUPS AU PROCÉDÉ CONTRÔLE LORSQU'IL EST INSÉRÉ DANS UNE SYSTÈME ACTIF. CES À-COUPS PEUVENT ÉGALEMENT OCCASIONNER DES BLESSURES OU DES DOMMAGES MATÉRIELS.

NOTICE

The information contained in this document is subject to change without notice.

Elsag Bailey, its affiliates, employees, and agents, and the authors and contributors to this publication specifically disclaim all liabilities and warranties, express and implied (including warranties of merchantability and fitness for a particular purpose), for the accuracy, currency, completeness, and/or reliability of the information contained herein and/or for the fitness for any particular use and/or for the performance of any material and/or equipment selected in whole or part with the user of/or in reliance upon information contained herein. Selection of materials and/or equipment is at the sole risk of the user of this publication.

This document contains proprietary information of Elsag Bailey, Elsag Bailey Process Automation, and is issued in strict confidence. Its use, or reproduction for use, for the reverse engineering, development or manufacture of hardware or software described herein is prohibited. No part of this document may be photocopied or reproduced without the prior written consent of Elsag Bailey.

Preface

Termination units provide an input from the plant equipment to the INFI 90[®] modules. The NTAI05 Analog Input Termination Unit connects the IMASM01 and NASM01 Analog Slave Modules, or the IMASI02 and NASI02 Analog Slave Input Modules, or the IMFBS01 Field Bus Slave Module with two-wire transmitters.

This manual explains how to install and use the NTAI05 termination unit in the INFI 90 system. It contains sections that describe setup and cabling. The appendices contain data about the IMASM01, IMFBS01, and IMASI02 modules.

[®] - Registered trademark of Eltag Bailey Process Automation.

List of Effective Pages

Total number of pages in this instruction is 28, consisting of the following:

Page No.	Change Date
Preface	Original
List of Effective Pages	Original
iii through vi	Original
1-1 through 1-5	Original
2-1 through 2-7	Original
3-1	Original
4-1 through 4-2	Original
5-1	Original
A-1	Original
B-1 through B-2	Original
C-1 through C-2	Original
Index-1	Original

When an update is received, insert the latest changed pages and dispose of the superseded pages.

NOTE: On an update page, the changed text or table is indicated by a vertical bar in the outer margin of the page adjacent to the changed area. A changed figure is indicated by a vertical bar in the outer margin next to the figure caption. The date the update was prepared will appear beside the page number.

Safety Summary

GENERAL WARNINGS

Equipment Environment

All components, whether in transportation, operation or storage, must be in a noncorrosive environment.

Electrical Shock Hazard During Maintenance

Disconnect power or take precautions to insure that contact with energized parts is avoided when servicing.

SPECIFIC CAUTIONS

Remove modules from their module mounting unit slots before installing or removing a cable assigned to that slot. Failure to do so could result in damage to the module. (p. 2-5, 4-1)

We strongly recommend that you turn off cabinet power before doing any termination unit wiring. Failure to do so could result in equipment damage. Do not apply power until you verify all wire connections. (p. 2-6)

If input or output circuits are a shock hazard after disconnecting system power at the power entry panel, then the door of the cabinet containing these externally powered circuits must be marked with a warning stating that multiple power sources exist. (p. 2-6, 4-1)

Sommaire de Sécurité

**AVERTISSEMENTS
D'ORDRE
GÉNÉRAL****Environnement de l'équipement**

Ne pas soumettre les composants à une atmosphère corrosive lors du transport, de l'entreposage ou l'utilisation.

Possibilité de chocs électriques durant l'entretien

Débrancher l'alimentation ou prendre les précautions pour éviter tout contact avec des composants sous tension durant l'entretien.

**ATTENTIONS
D'ORDRE
SPÉCIFIQUE**

Retirer le module de son emplacement dans le châssis de montage des modules avant d'installer ou de retirer un câble assigné à cet emplacement. Un manquement à cette procédure pourrait endommager le module. (p. 2-5, 4-1)

Il est fortement recommandé de débrancher l'alimentation électrique du cabinet avant d'effectuer toute connexion aux cartes de raccordement du châssis. Des dommages aux équipements pourraient survenir dans le cas contraire. Ne pas rebrancher l'alimentation avant que toutes les connexions aient été vérifiées. (p. 2-6)

Si des circuits d'entrée ou de sortie sont alimentés à partir de sources externes, ils présentent un risque de choc électrique même lorsque l'alimentation du système est débranchée du panneau d'entrée l'alimentation. Le cas échéant, un avertissement signalant la présence de sources d'alimentation multiples doit être apposé sur la porte de l'armoire. (p. 2-6, 4-1)

Table of Contents

	<i>Page</i>
SECTION 1 - INTRODUCTION	1-1
OVERVIEW	1-1
INTENDED USER	1-1
TERMINATION UNIT DESCRIPTION	1-1
FEATURES	1-1
INSTRUCTION CONTENT	1-3
HOW TO USE THIS MANUAL	1-3
REFERENCE DOCUMENTS	1-3
GLOSSARY OF TERMS AND ABBREVIATIONS	1-4
SPECIFICATIONS	1-4
NOMENCLATURE	1-5
SECTION 2 - INSTALLATION	2-1
INTRODUCTION	2-1
SPECIAL HANDLING	2-1
UNPACKING AND INSPECTION	2-2
SETUP/INSTALLATION	2-2
Dipshunt Settings	2-2
Physical Installation	2-2
Cable Connections	2-4
Terminal Block Wiring	2-5
Power Wiring	2-7
SECTION 3 - MAINTENANCE	3-1
INTRODUCTION	3-1
MAINTENANCE SCHEDULE	3-1
SECTION 4 - REPAIR/REPLACEMENT PROCEDURES	4-1
INTRODUCTION	4-1
REPLACEMENT PROCEDURES	4-1
SECTION 5 - SUPPORT SERVICES	5-1
INTRODUCTION	5-1
REPLACEMENT PARTS AND ORDERING INFORMATION	5-1
TRAINING	5-1
TECHNICAL DOCUMENTATION	5-1
APPENDIX A - IMASI02 ANALOG SLAVE INPUT MODULE	A-1
INTRODUCTION	A-1
APPENDIX B - IMASM01 ANALOG SLAVE MODULE	B-1
INTRODUCTION	B-1
APPENDIX C - IMFBS01 FIELD BUS SLAVE MODULE	C-1
INTRODUCTION	C-1

List of Tables

<i>No.</i>	<i>Title</i>	<i>Page</i>
1-1.	Reference Documents	1-3
1-2.	Glossary of Terms and Abbreviations	1-4
1-3.	Specifications	1-4
1-4.	Nomenclature	1-5
2-1.	Dipshunt Settings for NTAI051 Termination Unit	2-3
2-2.	NTAI05 Cable Applications	2-4
3-1.	Maintenance Schedule.....	3-1
A-1.	IMASI02 Address Switch Settings (SW1)	A-1
B-1.	IMASM01 Address Switch Settings (SW1/SW2)	B-2
C-1.	IMFBS01 Address Switch Settings (SW1)	C-2
C-2.	IMFBS01 Jumper Settings.....	C-2

List of Figures

<i>No.</i>	<i>Title</i>	<i>Page</i>
1-1.	Application Example for the NTAI05 Termination Unit	1-2
2-1.	Installation for NTAI05 Termination Unit	2-3
2-2.	Cable Connections.....	2-4
2-3.	NTAI05 Termination Unit.....	2-4
2-4.	NTAI05 Typical Input Circuit	2-6
A-1.	IMASI02 Slave Module	A-1
B-1.	IMASM01 Slave Module	B-1
C-1.	IMFBS01 Slave Module.....	C-1

SECTION 1 - INTRODUCTION

OVERVIEW

The NTAI05 Analog Input Termination Unit inputs 15 or 16 channels of analog signals depending on slave module type. It connects a slave module to field equipment and Bailey Controls smart transmitters. The signals pass through slave modules to the IMMFP01, IMMFP02 and IMMFP03 INFI 90 Multi-Function Processors, IMAMM03 Analog Master Modules or NMFC03, NMFC04 and NMFC05 Multi-Function Controllers.

This manual explains the purpose, setup, handling precautions and steps to install the NTAI05 unit. Refer to the **Table of Contents** to find the information needed. Refer to the **HOW TO USE THIS MANUAL** entry in this section to get started.

INTENDED USER

System engineers and technicians should read this manual before installing and using the NTAI05 unit. Install and power up the unit only after reading and understanding this manual.

TERMINATION UNIT DESCRIPTION

The NTAI05 unit is a single printed circuit board that mounts to an NFTP01 Field Termination Panel. The termination unit (TU) has one cable connector for signals. P1 carries the inputs to the slave module through the cable. The terminal blocks for field wiring are on the termination unit.

The dipshunts on the NTAI05 unit set the input type. Refer to the appendix for the switch settings of the slave module used. Be sure to check the switch setting before inserting the module into the module mounting unit (MMU). Figure 1-1 shows an example of the NTAI05 unit in a system.

FEATURES

The design of the NTAI05 unit, as with all INFI 90 devices, allows for flexibility in creating a process management system. Refer to the **NOMENCLATURE** entry of this section for the list of devices that can be used with the termination unit in an INFI 90 system.

- A standard factory-wired cable connects the termination unit to the slave module.
- On-board terminal blocks accept field and I/O wiring.

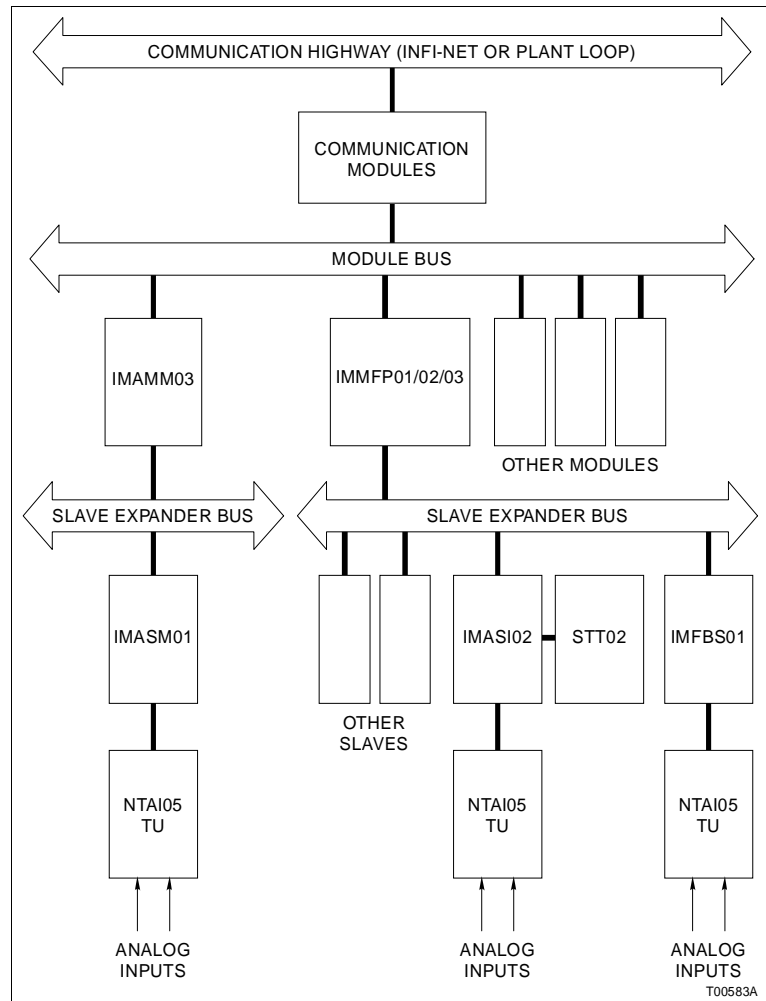

Figure 1-1. Application Example for the NTAI05 Termination Unit

- Analog inputs routed between field devices and I/O modules.
- The termination unit has no serviceable parts.
- Inputs may be either system or externally powered.

The NTAI05 unit handles up to 15 analog inputs for the IMASI02 and IMFBS01 modules or 16 analog inputs for the IMASM01 modules (inputs may be differential or single ended). The input signal types that can be handled by the various slave modules and configured by dipshunts on the NIAI05 unit are listed.

- 4 to 20 milliamps DC, system or externally powered.
- -10 VDC to +10 VDC.
- 0 VDC to 10 VDC.
- 1 VDC to 5 VDC.
- 0 VDC to 5 VDC.
- 0 VDC to 1 VDC (IMASI02/IMFBS01 only).

INSTRUCTION CONTENT

This manual has five sections and three appendices.

Introduction	Contains an overview of the termination unit: features, description and specifications.
Installation	Describes cautions to observe when handling the termination unit. It shows the steps needed to install and connect the unit before applying power. This section also presents dipshunt settings.
Maintenance	Provides a maintenance schedule.
Repair/Replacement Procedures	Details how to replace an NTAI05 unit.
Support Services	Describes the support services (repair parts, training, documentation, etc.) available from Bailey Controls Company.
Appendix A	Shows the IMASI02 Analog Slave Input Module.
Appendix B	Shows the IMASM01 Analog Slave Module.
Appendix C	Shows the IMFBS01 Field Bus Slave.

HOW TO USE THIS MANUAL

Read this manual before connecting the termination unit. Refer to the sections in this list as needed for more information.

1. Read the installation section before connecting the NTAI05 unit.
2. Refer to Appendix A, B or C for the slave module connected to the termination unit for more information.
3. Refer to the maintenance section for a maintenance schedule.
4. Refer to the repair/replacement procedures and support services sections when needed.

REFERENCE DOCUMENTS

Table 1-1 contains the reference documents for the NTAI05 unit.

Table 1-1. Reference Documents

Number	Description
I-E96-205	Analog Master Module and Analog Slave Modules (IMAMM03 and IMASM01/02/03/04)
I-E96-302	Field Bus Slave Module (IMFBS01)
I-E96-304	Analog Input Slave Module (IMASI02)

GLOSSARY OF TERMS AND ABBREVIATIONS

Table 1-2 contains the glossary of terms for this manual.

Table 1-2. Glossary of Terms and Abbreviations

Term	Definition
Analog	Continuously variable as opposed to discretely variable.
Dipshunt	Dual in-line package with shorting bars.
Dipswitch	A dual in-line package that contains single pole switches.
MMU	Module mounting unit. A card cage that provides electrical and communication support for INFI 90/Network 90 [®] modules.
Smart Transmitter	A field measuring device that can handle digital communication. It allows configuring of operating parameters, on-line parameter changes and remote troubleshooting.
TU	Termination unit. Provides input/output connection between plant equipment and the INFI 90 process modules. The termination unit mounts to a field termination panel.

SPECIFICATIONS

Refer to Table 1-3 for the specifications of the NTAI05 termination unit.

Table 1-3. Specifications

Property	Characteristic/Value
Power Requirements	+24 VDC 20 mA per input
Mounting	Mounts in the NFTP01 Field Termination Panel.
Environmental:	
Electromagnetic/ Radio Frequency Interference	No values available at this time. Keep cabinet doors closed. Do not use communication equipment closer than 2 meters from the cabinet.
Ambient Temperature	0° to 70°C (32° to 158°F).
Relative Humidity	0% to 95% up to 55°C (131°F) (noncondensing). 0% to 45% up to 70°C (158°F) (noncondensing).
Atmospheric Pressure	Sea level to 3 km (1.86 mi).
Air Quality	Noncorrosive.
Cooling Requirements	No cooling is necessary when used in Bailey cabinets and operated within stated limits.
Certification	CSA certified for use as process control equipment in an ordinary (nonhazardous) location.

SPECIFICATION SUBJECT TO CHANGE WITHOUT NOTICE

NOMENCLATURE

Table 1-4 contains the modules and equipment that can be used with the NTAIO5 termination unit.

Table 1-4. Nomenclature

Nomenclature	Description
IMASIO2	Analog Input Slave Module
IMASM01	Analog Slave Module
IMFBS01	Field Bus Slave Module
NFTP01	Field Termination Panel
NKTU01	Cable, Termination Unit (PVC)
NKTU11	Cable, Termination Unit (non-PVC)
STT02	Smart Transmitter Terminal

SECTION 2 - INSTALLATION

INTRODUCTION

This section explains how to install the NTAIO5 Analog Input Termination Unit. Read, understand and complete the steps in the order they appear before using the NTAIO5 unit.

SPECIAL HANDLING

Observe these steps when handling electronic circuitry:

NOTE: Always use the Bailey Controls Field Static Kit (part number 1948385A1 - consisting of two wrist straps, ground cord assembly, alligator clip and static dissipating work surface) when working with modules. The kit is designed to connect the technician and the static dissipating work surface to the same ground point to prevent damage to the modules by electrostatic discharge.

Use the static grounding wrist strap when installing and removing modules. Static discharge may damage MOS devices on modules in the cabinet. Use grounded equipment and static safe practices when working with modules.

1. **Use Static Shielding Bags.** Keep the modules in the static shielding bag until they are ready to be used in the system. Save the bag for future use.
2. **Ground Bags Before Opening.** Before opening a bag containing an assembly with CMOS devices, touch it to the equipment housing or ground to equalize charges.
3. **Avoid Touching Circuitry.** Handle assemblies by the edges; avoid touching the circuitry.
4. **Avoid Partial Connection of CMOS Device.** Verify that all devices connected to the modules are properly grounded before using them.
5. **Ground Test Equipment.**
6. **Use an Antistatic Field Service Vacuum.** Remove dust from the module if necessary.
7. **Use a Grounded Wrist Strap.** Connect the wrist strap to the appropriate grounding plug on the power entry panel. The grounding plug on the power entry panel is connected to the DC common bus.
8. **Do Not Use Lead Pencils to Set Dipswitches.** To avoid contamination of switch contacts that can result in circuit board malfunction, do not use a lead pencil to set a dipswitch.

UNPACKING AND INSPECTION

These are steps to follow for general handling:

1. Examine the unit to make sure that no damage has occurred in transit.
2. Notify the nearest Bailey Controls Sales/Service Office of any damage.
3. File a claim for any damage with the shipping company that handled the shipment.
4. Use the original packing material or container to store the unit.
5. Store the unit in a place with clean air; free from extremes of temperature and humidity.

SETUP/INSTALLATION

This section explains how to configure and install the NTAI05 termination unit. The required procedures are cutting the dipshunts, installing the termination unit, and connecting the field wiring and termination cables.

Dipshunt Settings

The dipshunts select the input type to match the device connected to the termination unit. Each channel is independent. The selections include voltage or current input, differential or single ended, system or externally powered. Set the dipshunts according to the instructions for the slave and input type used. Refer to Table 2-1 for an example of dipshunts.

Physical Installation

NOTE: This section provides data to install the termination unit only. For more slave information, refer to the instruction manual for the slave module used.

The termination unit mounts on a standard NFTP01 Field Termination Panel. Figure 2-1 shows how to secure the termination unit to the field termination panel. To install:

1. Insert the termination unit tabs into the slots in the outside edge of the termination panel.
2. Mount the termination unit to the field termination panel with two number 10, $\frac{3}{4}$ -inch screws. Do not over tighten the screws.

Table 2-1. Dipshunt Settings for NTAI05¹ Termination Unit

Application/Signal Type	Dipshunt Configuration ²	Dipshunt Locations	Connecting Cable
System powered 4-20 mA		XU1-XU15 on IMASI02 or IMFBS01 XU1-XU16 on IMASM01	NKTU01/11
Externally powered 4-20 mA			
Single ended voltage			
Differential voltage			
IMASI01, IMFBS01 ³		XU17	
IMASM01			

NOTES:

1. Dipshunt settings are shown for IMASM01, IMASI02, and IMFBS01 in point-to-point mode.
2. Strap one connects pin one to pin 16, strap two connects pin two to pin 15, etc.
3. Input 16 on NTAI05 is not used with IMASI02 and IMFBS01.

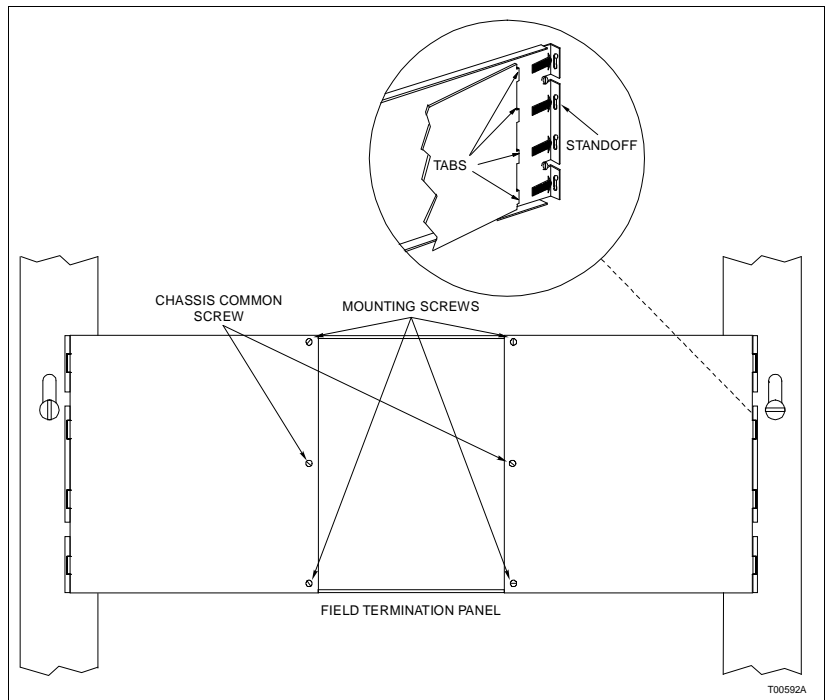

Figure 2-1. Installation for NTAI05 Termination Unit

Cable Connections

The NTAI05 termination unit has one cable connector (P1) to provide analog inputs to the slave module. Install the termination connector cable (NKTU01) to connect the termination unit to the slave module for communication. See Figure 2-2 for the termination unit cable connections. Figure 2-3 shows the NTAI05 termination unit. Table 2-2 contains the NTAI05 cable connections.

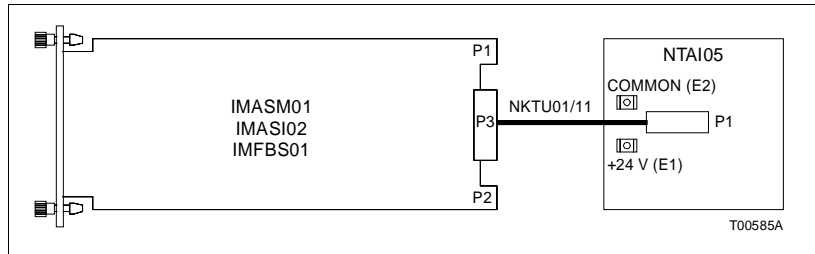

Figure 2-2. Cable Connections

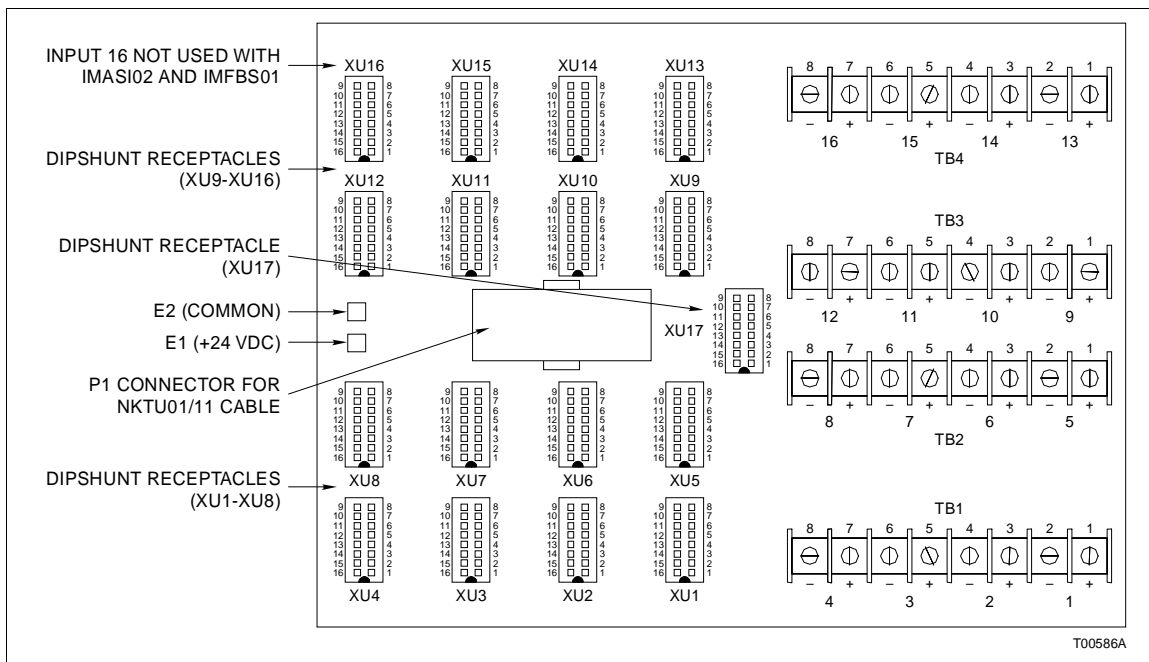

Figure 2-3. NTAI05 Termination Unit

Table 2-2. NTAI05 Cable Applications

Nomenclature/Description	Application	Connector	Maximum Length
NKTU01 (PVC Jacket)	Connects NTAI05 to IMASI02, IMFBS01, or IMASM01	P1 on TU to MMU backplane	61m (200 ft)
NKTU11 (non-PVC Jacket)			

CAUTION

Remove modules from their module mounting unit slots before installing or removing a cable assigned to that slot. Failure to do so could result in damage to the module.

ATTENTION

Retirer le module de son emplacement dans le châssis de montage des modules avant d'installer ou de retirer un câble assigné à cet emplacement. Un manquement à cette procédure pourrait endommager le module.

Make connections to the termination unit after it is mounted in the field termination panel. To install the cable follow these steps.

1. Verify slave module (IMASM01, IMASIO2 or IMFBS01) is unplugged from the MMU backplane.
2. Insert the hooded end of an NKTU01 or NKTU11 cable into the MMU backplane slot assigned to the slave module. The cable should latch securely in place. Card edge connector P3 of the slave module connects to this end of the cable.
3. Insert the male 36 pin connector end of the NKTU01 or NKTU11 cable from the slave module into the P1 connector of the termination unit. The cable should latch securely in place.
4. Slide the slave module into the module mounting unit until the module is fully seated and the faceplate is flush with the front of the rack.

Terminal Block Wiring

Connect the wiring to the termination unit terminals from the input devices sensing the process. Input devices may be: BC/BCN series Bailey Controls Pressure Transmitters, EQ/EQN series Bailey Controls Temperature Transmitters, pH series Bailey Controls pH/TBN Transmitters or any conventional transmitter. See Figure 2-4 for an example of an NTAIO5 input circuit.

Field wiring should be 12 to 22 AWG wire. Refer to the **Site Planning and Preparation** manual for information on field wiring such as noise immunity and spacing requirements.

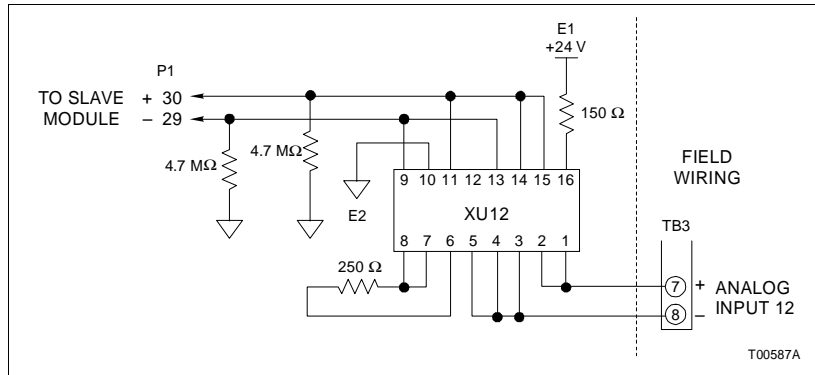

Figure 2-4. NTAI05 Typical Input Circuit

CAUTION

We strongly recommend that you turn off cabinet power before doing any termination unit wiring. Failure to do so could result in equipment damage. Do not apply power until you verify all wire connections.

ATTENTION

Il est fortement recommande de debrancher l'alimentation electrique du cabinet avant d'effectuer tout connexion aux cartes de raccordement du chassis. Des dommages aux equipments pourraient survenir dans le cas contraire. Ne pas rebrancher l'alimentation avant que toutes les connexions aient ete verifiees.

CAUTION

If input or output circuits are a shock hazard after disconnecting system power at the power entry panel, then the door of the cabinet containing these externally powered circuits must be marked with a warning stating that multiple power sources exist.

ATTENTION

Si des circuits d'entree ou de sortie sont alimentes a partir de sources externes, ils presentent un risque de choc electrique meme lorsque l'alimentation du systeme est debranchee du panneau d'entree l'alimentation. Le cas echeant, un avertissement signalant la presence de sources d'alimentation multiples doit etre appose sur la porte de l'armoire.

To connect field wiring, follow these steps:

1. Remove power from the cabinet.
2. Connect the field wires to the terminal blocks.

Power Wiring

This section explains how to connect power wiring. The NTAIO5 unit has two fast-on connections for power and I/O common. Make power connections to the termination unit after it is mounted in the NFTP01 termination panel. Make sure cabinet and I/O power are turned off before connecting ground and power wiring.

Use 14 gauge wire for power wiring. To connect power to the termination unit in a system using modular power supplies:

1. Attach a 14 AWG wire from the system +24 VDC supply to the E1 fast-on connector.
2. Attach a 14 AWG wire from the DC bus bar at the bottom of the cabinet to the E2 fast-on connector.

The NTAIO5 unit is ready for operation if:

1. The circuit board is mounted in the field termination panel.
2. The dipshunts are cut and verified.
3. All required cables are connected to the termination unit.
4. All required field wires are connected to the termination unit and have been verified.
5. Power is connected and applied to the termination unit.

SECTION 3 - MAINTENANCE

INTRODUCTION

The NTAI05 Analog Input Termination Unit requires limited maintenance. This section contains a maintenance schedule.

MAINTENANCE SCHEDULE

Execute the tasks in Table 3-1 at the specified intervals.

Table 3-1. Maintenance Schedule

Task	Interval
Clean and tighten all power and grounding connections.	Every 6 months or during plant shutdown, whichever occurs first.
Use a static safe vacuum cleaner to remove dust from: Field termination panel. Termination units.	

SECTION 4 - REPAIR/REPLACEMENT PROCEDURES

INTRODUCTION

This section explains the replacement procedures for the NTAI05 Analog Input Termination Unit.

REPLACEMENT PROCEDURES

If a termination unit is faulty, replace it with a new one. **Do not** try to repair the module. Replacing components may affect performance and certification.

CAUTION	Remove modules from their module mounting unit slots before installing or removing a cable assigned to that slot. Failure to do so could result in damage to the module.
ATTENTION	Retirer le module de son emplacement dans le chassis de montage des modules avant d'installer ou de retirer un câble assigne a cet emplacement. Un manquement à cette procédure pourrait endommager le module.

CAUTION	If input or output circuits are a shock hazard after disconnecting system power at the power entry panel, then the door of the cabinet containing these externally powered circuits must be marked with a warning stating that multiple power sources exist.
ATTENTION	Si des circuits d'entree ou de sortie sont alimentes a partir de sources externes, ils presentent un risque de choc electrique meme lorsque l'alimentation du systeme est debranchee du panneau d'entree l'alimentation. Le cas echeant, un avertissement signalant la presence de sources d'alimentation multiples doit etre appose sur la porte de l'armoire.

To replace a termination unit:

1. Turn **off** the INFI 90 cabinet power.

NOTE: The I/O power supplies providing the power to the termination unit may not be located in the same cabinet as the termination unit. Make sure to turn **off** power to any external supplies providing I/O power.

2. Pull the associated slave module out of the cable connector.
3. Label and remove all field wiring from the terminal blocks.

4. Label and disconnect the cable connected to the termination unit.
5. Label and disconnect system I/O power and ground wires from the terminals.
6. Remove the two number 10 screws securing the termination unit to the field termination panel.
7. Remove the dipshunts from the defective termination unit and place them in the same socket of the new termination unit (or cut the dipshunts included with the replacement unit). Be sure to install the dipshunt correctly so that no pins are bent over.
8. Insert the tabs of the replacement circuit board into the proper slots of the field termination panel stand-off and slide the circuit board into position.
9. Secure the termination unit circuit board to the field termination panel with the two number 10 screws.
10. Connect all field wiring removed in Step 3 and verify connections.
11. Connect the system I/O power and ground wires removed in Step 5 and verify connections.
12. Connect the cable removed in Step 4 and verify the connection.
13. Energize the cabinet power supply that provides power to the termination unit.
14. Turn on any external power supplies providing I/O power.
15. Insert the slave module into the MMU backplane.

SECTION 5 - SUPPORT SERVICES

INTRODUCTION

Bailey Controls Company is ready to help in the use, application and repair of its products. Contact the nearest sales office to make requests for sales, applications, installation, repair, overhaul and maintenance contract services.

REPLACEMENT PARTS AND ORDERING INFORMATION

When making repairs, order replacement parts from a Bailey Controls sales office. Provide this information:

1. Part description, part number and quantity.
2. Model and serial numbers (if applicable).
3. Bailey instruction manual number, page number and reference figure that identifies the part.

Order parts without commercial descriptions from the nearest Bailey Controls Company sales office.

TRAINING

Bailey Controls has a modern training facility available for training your personnel. On-site training is also available. Contact a Bailey Controls sales office for specific information and scheduling.

TECHNICAL DOCUMENTATION

Additional copies of this manual, or other Bailey Controls Company manuals, can be obtained from the nearest Bailey Controls Company sales office at a reasonable charge.

APPENDIX A - IMASIO2 ANALOG SLAVE INPUT MODULE

INTRODUCTION

The IMASIO2 Analog Slave Input Module uses an NTAIO5 unit for termination. Dipshunts on the NTAIO5 termination unit configure the fifteen analog inputs for the IMASIO2 slave. The IMASIO2 slave accepts inputs of four to 20 milliamps, one to five VDC, zero to one VDC, zero to five VDC, zero to ten VDC and -10 VDC to +10 VDC (Bailey Controls smart transmitters).

This appendix contains figures and tables that show dipswitch locations on the IMASIO2 slave and its settings. This information is provided as a quick reference guide for personnel installing the NTAIO5 termination unit.

Figure A-1 shows the termination unit dipshunt settings for the IMASIO2 slave. Table A-1 lists the address switch settings. Be sure to check the dipswitches before installing the IMASIO2 slave. Refer to the IMASIO2 instruction for more detailed information to install and configure the slave.

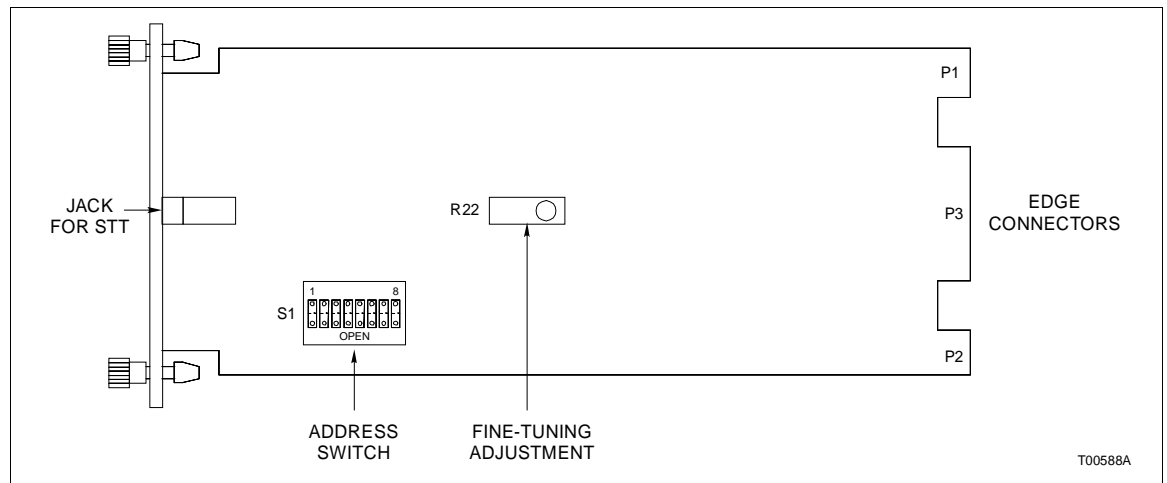

Figure A-1. IMASIO2 Slave Module

Table A-1. IMASIO2 Address Switch Settings (SW1)

Address Example	Switch Position								Address Example	Switch Position							
	MSB				LSB					MSB				LSB			
	1	2	3	4	5	6	7	8		1	2	3	4	5	6	7	8
0	0	0	0	0	0	0	0	0	32	0	0	1	0	0	0	0	0
9	0	0	0	0	1	0	0	1	41	0	0	1	0	1	0	0	1
16	0	0	0	1	0	0	0	0	48	0	0	1	1	0	0	0	0
31	0	0	0	1	1	1	1	1	63	0	0	1	1	1	1	1	1

OPEN = OFF = 1
CLOSED = ON = 0

APPENDIX B - IMASM01 ANALOG SLAVE MODULE

INTRODUCTION

The IMASM01 Analog Slave Module uses an NTAI05 unit for termination. Dipshunts on the NTAI05 termination unit configure the sixteen analog inputs for the IMASM01 slave. The IMASM01 slave accepts inputs of four to 20 milliamps and one to five VDC, zero to five VDC, zero to ten VDC, and -10 to +10 VDC.

This appendix contains figures and tables that show the dipswitch location on the IMASM01 slave and its settings. This information is provided as a quick reference guide for personnel installing the NTAI05 termination unit.

Figure B-1 shows the termination unit dipshunt settings for the IMASM01 slave. Table B-1 lists the address switch settings. Be sure to check the dipswitches before installing the IMASM01 slave. Refer to the IMAMM03, IMASM01, IMASM02, IMASM03 and IMASM04 instruction for more detailed information to install and configure the IMASM01 slave.

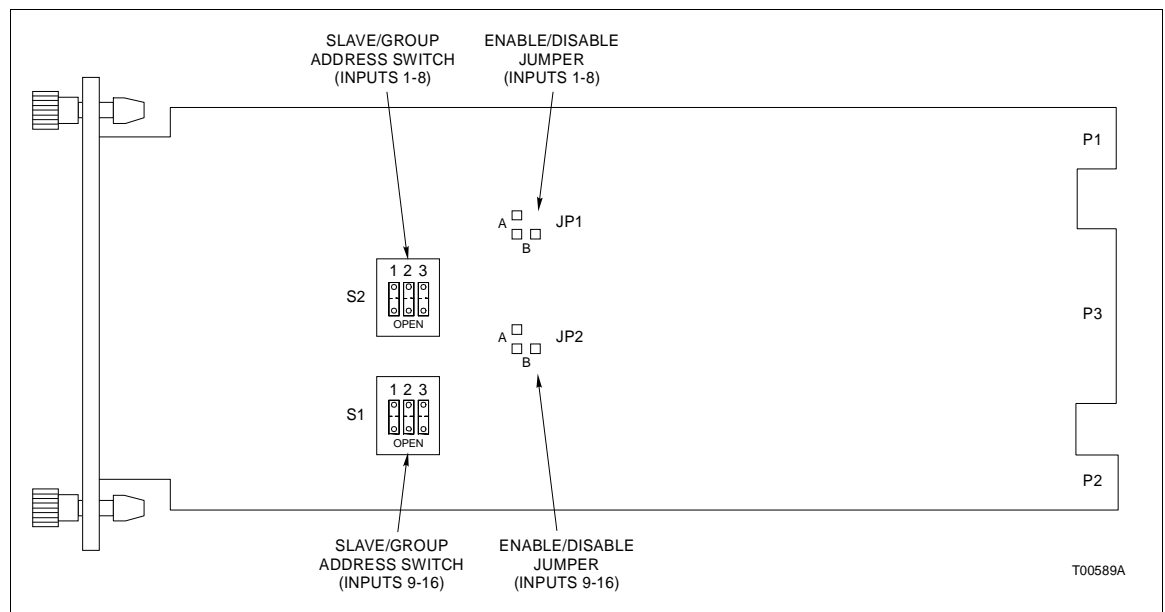

Figure B-1. IMASM01 Slave Module

Table B-1. IMASM01 Address Switch Settings (SW1/SW2)

Address Example	Switch Position			Address Example	Switch Position		
	MSB		LSB		MSB		LSB
	1	2	3		1	2	3
0	0	0	0	4	1	0	0
1	0	0	1	5	1	0	1
2	0	1	0	6	1	1	0
3	0	1	1	7	1	1	1

OPEN = OFF = 1
 CLOSED = ON = 0

Index

A	
Analog slave input module (IMASI02)	A-1
Analog slave module (IMASM01)	B-1
Application example for NTAI05	1-2
C	
Cable connections	2-4
D	
Dipshunt settings	
IMASI02/IMFBS in point-to-point mode	A-1
IMASM01	B-2
IMFBS01	C-2
F	
Features	1-1
Field bus slave module (IMFBS01)	C-1
G	
Glossary of terms and abbreviations	1-4
H	
How to use this manual	1-3
I	
Input termination example	2-6
Installation for NTAI05	2-3
Instruction content	1-3
Intended user	1-1
M	
Maintenance schedule	3-1
N	
Nomenclature	1-5
NTAI05 termination unit	2-4
Cable connections	2-4
Input circuit	2-6
O	
Overview	1-1
R	
Reference documents	1-3
Replacement parts and ordering	5-1
Replacement parts/ordering information	5-1
Replacement procedures	4-1
S	
Setup/installation	2-2
Cable connections	2-4
Dipshunt settings	2-2
Physical installation	2-2
Power wiring	2-7
Terminal block wiring	2-5
Special handling	2-1
Specifications	1-4
T	
Technical documentation	5-1
Terminal assignments	2-5
Termination unit description	1-1
Training	5-1
U	
Unpacking and inspection	2-2

Visit Elsasg Bailey on the World Wide Web at <http://www.bailey.com>

Our worldwide staff of professionals is ready to meet *your* needs for process automation.
For the location nearest you, please contact the appropriate regional office.

AMERICAS

29801 Euclid Avenue
Wickliffe, Ohio USA 44092
Telephone 1-216-585-8500
Telefax 1-216-585-8756

ASIA/PACIFIC

152 Beach Road
Gateway East #20-04
Singapore 189721
Telephone 65-391-0800
Telefax 65-292-9011

EUROPE, AFRICA, MIDDLE EAST

Via Puccini 2
16154 Genoa, Italy
Telephone 39-10-6582-943
Telefax 39-10-6582-941

GERMANY

Graefstrasse 97
D-60487 Frankfurt Main
Germany
Telephone 49-69-799-0
Telefax 49-69-799-2406