



Technical Product Guide

Tricon Systems

Introduction	1
Theory of Operation	3
System Configuration	11
Product Specifications	17
Field Termination Options.....	47
Communication Capabilities	59
TriStation 1131 Developer's Workbench	63
CEM Programming Language Editor.....	67
Sequence of Events (SOE) Capability.....	69
Part Number Cross-Reference	71
Glossary.....	73

Preface

Information in this document is subject to change without notice. Companies, names and data used in examples herein are fictitious unless otherwise noted. No part of this document may be reproduced or transmitted in any form or by any means, electronic or mechanical, for any purpose, without the express written permission of Triconex.

© 2006 Invensys Systems, Inc. All Rights Reserved.

Triconex, Tricon, Trident, TriStation 1131, and CEMPLE are trademarks of Invensys plc, its subsidiaries and affiliates. All other brands may be trademarks of their respective owners.

DISCLAIMER

Because of the variety of uses for this equipment and because of the differences between this fault-tolerant equipment and traditional programmable logic and process controllers, the user of, and those responsible for applying, this equipment must satisfy themselves as to the acceptability of each application and the use of the equipment.

The illustrations, charts and layout examples shown in this manual are intended solely to illustrate the text of this manual. Because of the many variables and requirements associated with any particular installation, Invensys Systems, Inc. cannot assume responsibility or liability for actual use based upon the illustrative uses and applications.

In no event will Invensys Systems, Inc. be responsible or liable for indirect or consequential damages resulting from the use or application of this equipment.

INVENSYS SYSTEMS, INC. DISCLAIMS ANY IMPLIED WARRANTY OF FITNESS FOR A PARTICULAR PURPOSE.

Invensys Systems, Inc. reserves the right to make changes at any time in order to improve design and to supply the most reliable product. No patent or copyright liability is assumed by Invensys Systems, Inc. with respect to use of information, circuits, equipment or software described in this text.

TECHNICAL SUPPORT

Customers in the U.S. and Canada can obtain technical support from the Customer Satisfaction Center (CSC) at the numbers below. International customers should contact their regional support center.

Telephone: T	oll-free number	866-746-6477
	Toll number	508-549-2424 (outside U.S.)
Fax:	Toll number	508-549-4999
E-mail:	ips.csc@ips.invensys.com	

The Tricon is a fault-tolerant controller based on a Triple-Modular Redundant (TMR) architecture.



Introduction

What is Fault-Tolerant Control?

A fault-tolerant control system identifies and compensates for failed control system elements and allows repair while continuing an assigned task without process interruption. A high-integrity control system such as the Tricon is used in critical process applications that require a significant degree of safety and availability.

What is the Tricon?

The Tricon is a state-of-the-art controller that provides fault tolerance by means of Triple-Modular Redundant (TMR) architecture. TMR integrates three isolated, parallel control systems and extensive diagnostics in one control system. The system uses two-out-of-three voting to provide high-integrity, error-free, uninterrupted process operation with no single point of failure.

The Tricon controller uses three identical channels. Each channel independently executes the control program in parallel with the other two channels. Specialized hardware/software voting mechanisms qualify and verify all digital inputs and outputs from the field, while analog inputs are subject to a mid-value selection process.

Because each channel is isolated from the others, no single-point failure in any channel can pass to another. If a hardware failure does occur on one channel, the other channels override it. Meanwhile the faulting module can easily be removed and replaced while the



The Tricon Fault-Tolerant Controller

controller is online without interrupting the process.

Setting up control programs is simplified with the triplicated Tricon system, because it operates as a single control system from the user's point of view. The user terminates sensors and actuators at a single wiring terminal and

programs the Tricon with one set of control program logic. The Tricon controller manages the rest!

Extensive diagnostics on each channel, module, and functional circuit immediately detect and report operational faults by means of indicators or alarms.

Introduction

All diagnostic fault information is accessible by the control program and the operator. The program or the operator can use diagnostic data to modify control actions or direct maintenance procedures.

Other key features of the Tricon controller that ensure the highest possible system integrity are:

- No single point of failure
- Ability to operate with 3, 2 or 1 Main Processor before shutdown
- Fully implemented and transparent triplication
- Comprehensive system diagnostics
- Complete range of I/O modules
- Dual and single I/O modules for safety-critical points with a limited need for availability
- Remote I/O up to 7.5 miles (12 kilometers) away from MPs
- Simple, online module repair
- Unsurpassed reliability and availability

What are Typical User Applications?

Each day the Tricon supplies increased safety, reliability and availability to a worldwide installed base. The following are a few typical applications. For more information on how a Tricon controller can add value to your applications, ask your sales representative for additional documentation and customer references.

Emergency Safety Shutdown (ESD)

The Tricon provides continuous protection for safety-critical units in refineries, petrochemical/chemical plants and other industrial processes. For example, in reactor and compressor units, plant trip signals—for pressure,

product feed rates, expander pressure equalization and temperature—are monitored and shutdown actions taken if an upset condition occurs. Traditional shutdown systems implemented with mechanical or electronic relays provide shutdown protection but can also cause dangerous nuisance trips.

The Tricon increases system integrity, providing automatic detection and verification of field sensor integrity, integrated shutdown and control functionality, and direct connection to the supervisory data highway for continuous monitoring of safety-critical functions.

Boiler Flame Safety

Process steam boilers function as a critical component in most refinery applications. Protection of the boiler from upset conditions, safety interlock for normal startup and shutdown, and flame-safety applications are combined by one integrated Tricon system. In traditional applications, these functions had to be provided by separate, non-integrated components. But with the fault-tolerant, fail-safe Tricon controller, the boiler operations staff can use a critical resource more productively while maintaining safety at or above the level of electromechanical protection systems.

Turbine Control Systems

The control and protection of gas or steam turbines requires high integrity as well as safety. The continuous operation of the fault-tolerant Tricon controller provides the turbine operator with maximum availability while maintaining equivalent levels of safety. Speed control as well as start-up and shutdown sequencing are implemented in a single integrated system. Unscheduled outages are avoided by using *hot-spares* for the I/O modules. If a fault occurs in a module, a replacement module is automatically activated without operator intervention.

Offshore Fire and Gas Protection

The protection of offshore platforms from fire and gas threats requires continuous availability as well as reliability. The Tricon provides this availability through *online replacement* of faulty modules. Faults in individual modules, field wiring and sensors are managed automatically by built-in diagnostics. Analog fire and gas detectors are connected directly to the Tricon, eliminating the need for trip amps. An operator interface monitors fire and gas systems as well as diagnostics for the Tricon controller and its attached sensors. Traditional fire and gas panels can be replaced with a single integrated system, saving costly floor space while maintaining high levels of safety and availability.

What is TriStation?

TriStation 1131 Developer's Workbench is an integrated tool for developing, testing and documenting control programs that execute in the Tricon controller. TriStation 1131 complies with the IEC 61131 International Standard for Programmable Controllers and follows the Microsoft Windows guidelines for graphical user interfaces.

What about Communication Capabilities?

Optional modules enable the Tricon to communicate with other Triconex controllers and with other hosts such as:

- Modbus masters and slaves
- Distributed Control Systems (DCS)
- Operator workstations
- Host computers using Ethernet (802.3) protocol

For more information, see "[Communication Capabilities](#)" on page 59.

The Tricon is designed with a fully triplicated architecture throughout, from the input modules through the main processors (MPs) to the output modules.

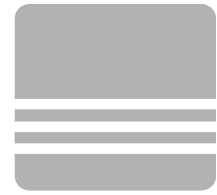

Theory of Operation

Fault tolerance in the Tricon is achieved by means of a Triple-Modular Redundant (TMR) architecture. The Tricon provides error-free, uninterrupted control in the presence of either hard failures of components, or transient faults from internal or external sources.

The Tricon is designed with a fully triplicated architecture throughout, from the input modules through the main processors to the output modules. Every I/O module houses the circuitry for three independent channels, which are also referred to as legs. Each channel on the input modules reads the process data and passes that information to its respective main processor. The three main processors communicate with each other using a proprietary high-speed bus system called the TriBus.

Once per scan, the three main processors synchronize and communicate with their two neighbors over the TriBus. The Tricon votes digital input data, compares output data, and sends copies of analog input data to each main processor.

The main processors execute the control program and send outputs generated by the control program to the output modules. The output data is voted on the output modules as close to the field as possible, which enables the Tricon to detect and compensate for any errors that might occur between the voting and the final output driven to the field.

For each I/O module, the system can support an optional hot-spare module

which takes control if a fault is detected on the primary module during operation. The hot-spare position can also be used for online system repairs.

Main Processor Modules

A Tricon system contains three main processor (MP) modules to control three separate channels of the system. Each main processor operates in parallel with the other two main processors, as a member of a triad.

memory for use in the hardware voting process.

The individual input table in each main processor is transferred to its neighboring main processors over the proprietary TriBus. During this transfer, hardware voting takes place. The TriBus uses a direct memory access (DMA) programmable device to synchronize, transmit, vote and compare data among the three main processors.

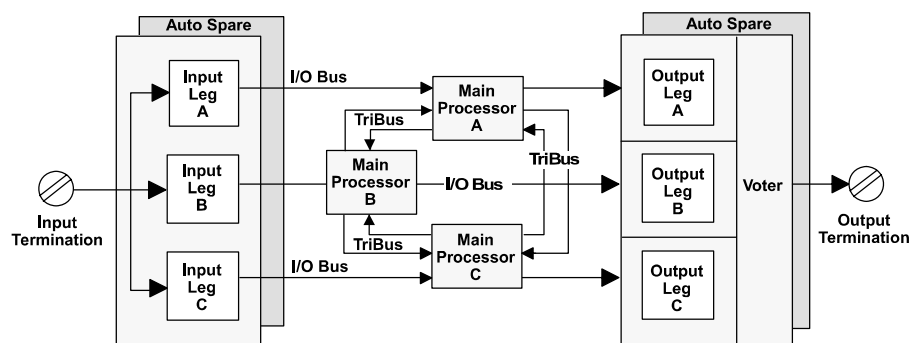

Simplified Tricon Architecture

A dedicated I/O and COMM processor on each main processor manages the data exchanged between the main processors and the I/O modules. A triplicated I/O bus is located on the chassis backplane and is extended from chassis to chassis by means of I/O bus cables.

As each input module is polled, the new input data is transmitted to the main processor over the appropriate channel of the I/O bus. The input data from each input module is assembled into a table in the main processor and stored in

If a disagreement is discovered, the signal value found in two out of three tables prevails, and the third table is corrected accordingly. One-time differences which result from sample timing variations can be distinguished from a pattern of differing data. The three independent main processors each maintain data about necessary corrections in local memory. Any disparity is flagged and used at the end of the scan by the built-in Fault Analyzer routines to determine whether a fault exists on a particular module.

Theory of Operation

After the TriBus transfer and input data voting have corrected the input values, these corrected values are used by the main processors as input to the user-written control program. (The control program is developed in the TriStation software and downloaded to the main processors.) The 32-bit main microprocessor executes the user-written control program in parallel with the neighboring main processor modules.

The user-written control program generates a table of output values based on the table of input values, according to the rules built into the control program by the customer. The I/O processor on each main processor manages the transmission of output data to the output modules by means of the I/O bus.

Using the table of output values, the I/O processor generates smaller tables, each corresponding to an individual output module in the system. Each small table is transmitted to the appropriate

channel of the corresponding output module over the I/O bus. For example, Main Processor A transmits the appropriate table to Channel A of each output module over I/O Bus A. The transmittal of output data has priority over the routine scanning of all I/O modules.

The I/O and COMM processor manages the data exchanged between the main processors and the communication modules using the communication bus, which supports a broadcast mechanism.

The model 3008 Main Processors provide 16 megabytes of DRAM, which is used for the control program, sequence-of-events data, I/O data, diagnostics and communication buffers.

In the event of an external power failure, the integrity of the user-written program and the retentive variables is protected for a minimum of six months.

The main processor modules receive power from dual power modules and power rails in the main chassis. A failure on one power module or power rail will not affect the performance of the system.

Bus Systems and Power Distribution

Three triplicated bus systems are etched on the chassis backplane: the TriBus, the I/O bus and the communication bus.

The TriBus consists of three independent serial links which operate at 25 megabits per second. The TriBus synchronizes the main processors at the beginning of a scan. Then each main processor sends its data to its upstream and downstream neighbors. The TriBus performs one of two functions with the data:

- Transfer of data only—for I/O, diagnostic and communication data.
- Comparing data and flagging disagreements—for the previous scan's output data and memory of user-written control program.

An important feature of the Tricon's fault-tolerant architecture is the use of a single transmitter to send data to both the upstream and downstream main processors. This ensures receipt of the same data by the upstream processor and downstream processor.

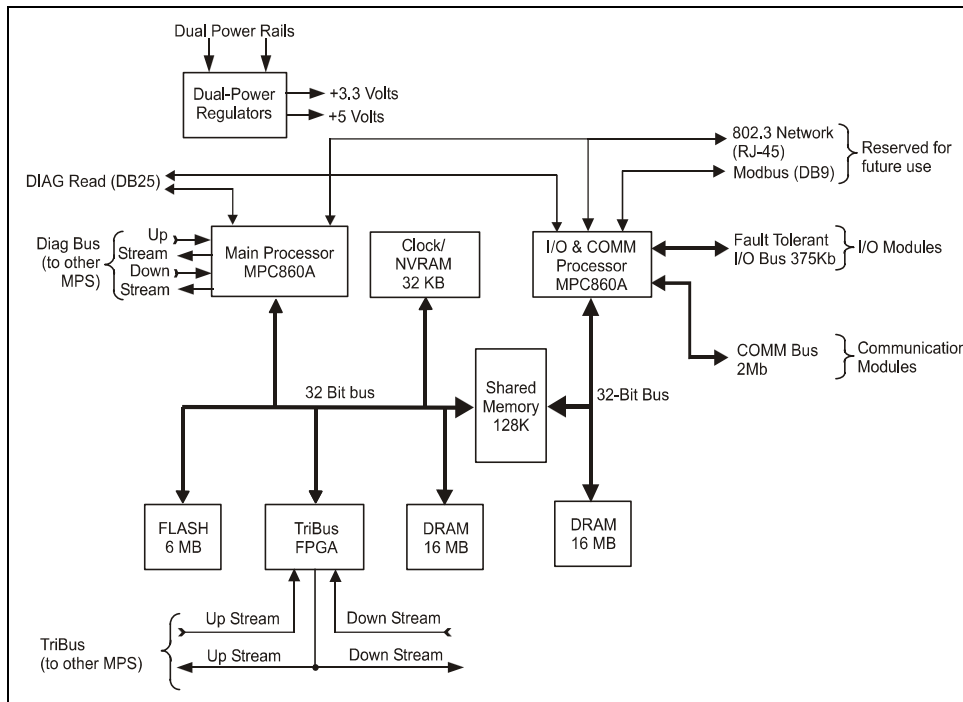

Main Processor (Model 3008) Architecture

I/O Bus

The triplicated I/O bus transfers data between the I/O modules and the main processors at 375 kilobits per second. The triplicated I/O bus is carried along the bottom of the backplane. Each channel of the I/O bus runs between one of the three main processors and the corresponding channels on the I/O module.

The I/O bus can be extended between chassis using a set of three I/O bus cables.

Communication Bus

The communication (COMM) bus runs between the main processors and the communication modules at 2 megabits per second.

Power for the chassis is distributed across two independent power rails down the center of the backplane. Every module in the chassis draws power from both power rails through dual power regulators. There are four sets of power regulators on each input and output module: one set for each of the channels A, B and C and one set for the status-indicating LED indicators.

Field Signals

Each I/O module transfers signals to or from the field through its associated field termination assembly. Two positions in the chassis tie together as one logical slot. The first position holds the active I/O module and the second position holds the hot-spare I/O module. Termination cables are connected to the top of the backplane. Each connection extends from the termination module to both active and hot-spare I/O modules. Therefore, both the active module and the hot-spare module receive the same information from the field termination wiring.

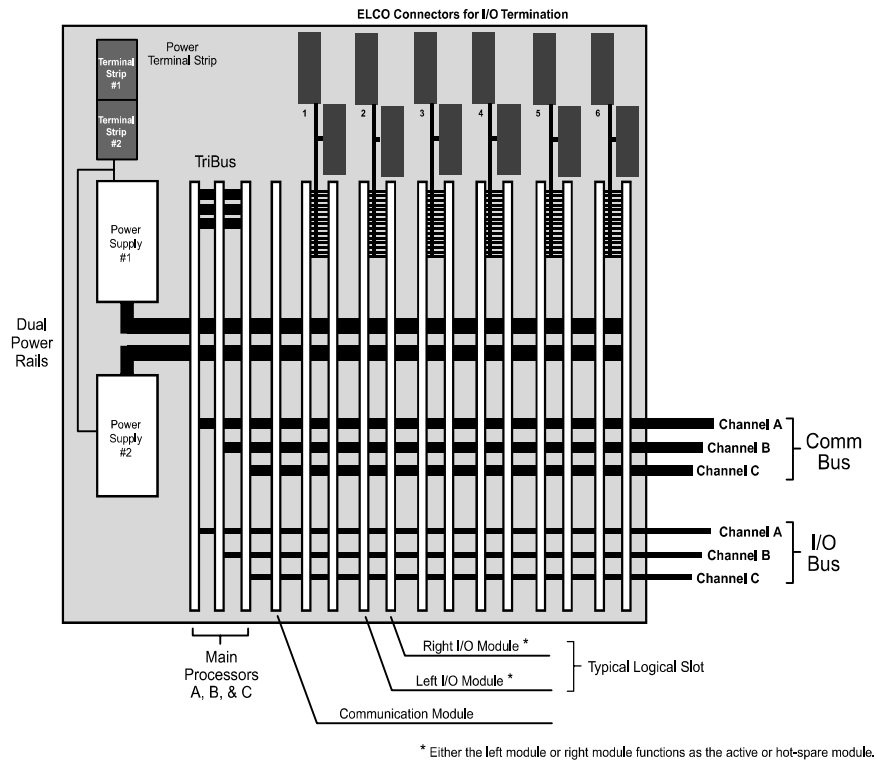

Backplane of the Main Chassis

Digital Input Modules

The Tricon supports two basic types of digital input modules: TMR and single. The following paragraphs describe digital input modules in general, followed by specifics for TMR and single modules.

Every digital input module houses the circuitry for three identical channels (A, B and C). Although the channels reside on the same module, they are completely isolated from each other and operate independently. A fault on one channel cannot pass to another. In addition, each channel contains an 8-bit microprocessor called the I/O communication processor, which handles communication with its corresponding main processor.

Each of the three input channels asynchronously measures the input signals from each point on the input termina-

tion module, determines the respective states of the input signals, and places the values into input tables A, B and C respectively. Each input table is regularly interrogated over the I/O bus by the I/O communication processor located on the corresponding main processor module. For example, Main Processor A interrogates Input Table A over I/O Bus A.

On TMR digital input modules, all critical signal paths are 100 percent triplicated for guaranteed safety and maximum availability. Each channel conditions signals independently and provides isolation between the field and the Tricon. (The 64-point high-density digital input module is an exception—it has no channel-to-channel isolation.)

DC models of the TMR digital input modules can self-test to detect stuck-ON conditions where the circuitry

Theory of Operation

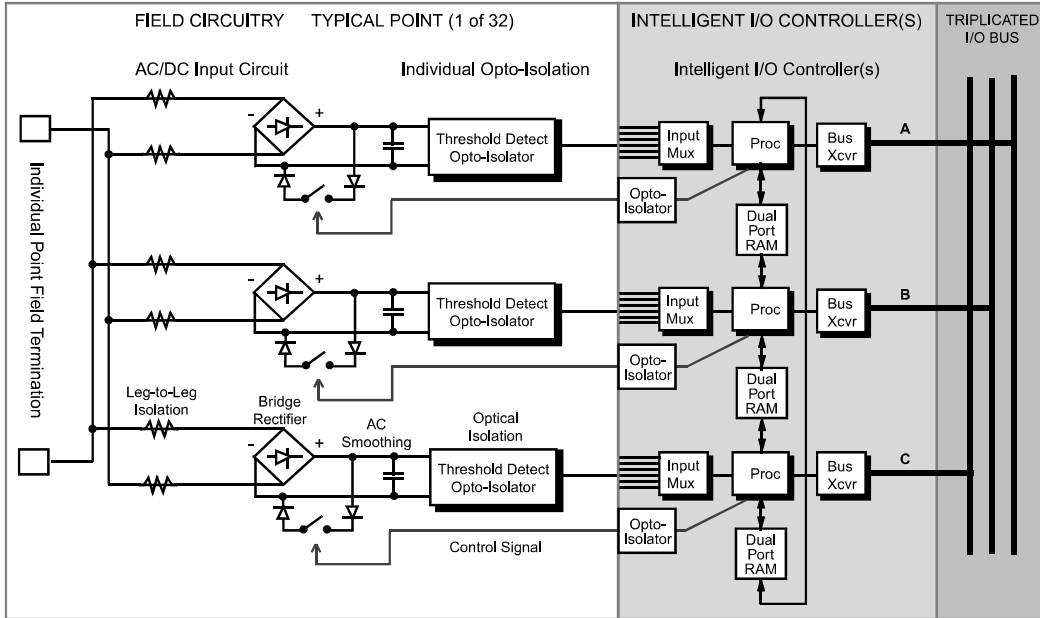

Architecture of TMR Digital Input Module with Self-Test (DC Model)

tory feature of a fail-safe system, which must detect all faults in a timely manner and upon detection of an input fault, force the measured input value to the safe state. Because the Tricon is optimized for de-energize-to-trip applications, detection of a fault in the input circuitry forces to OFF (the de-energized state) the value reported to the main processors by each channel.

cannot tell whether a point has gone to the OFF state. Since most safety systems are set up with a de-energize-to-trip capability, the ability to detect stuck-ON points is an important feature. To test for stuck-ON inputs, a switch within the input circuitry is closed to allow a zero input (OFF) to be read by the isolation circuitry. The last data reading is frozen in the I/O communication processor while the test is running.

On single digital input modules, only those portions of the signal path which are required to ensure safe operation are triplicated. Single modules are optimized for those safety-critical applications where low cost is more important than maximum availability. Special self-test circuitry detects all stuck-ON and

stuck-OFF fault conditions within the non-triplicated signal conditioners in less than half a second. This is a manda-

There are four basic types of digital output modules: dual, supervised, DC voltage and AC voltage. The following

Digital Output Modules

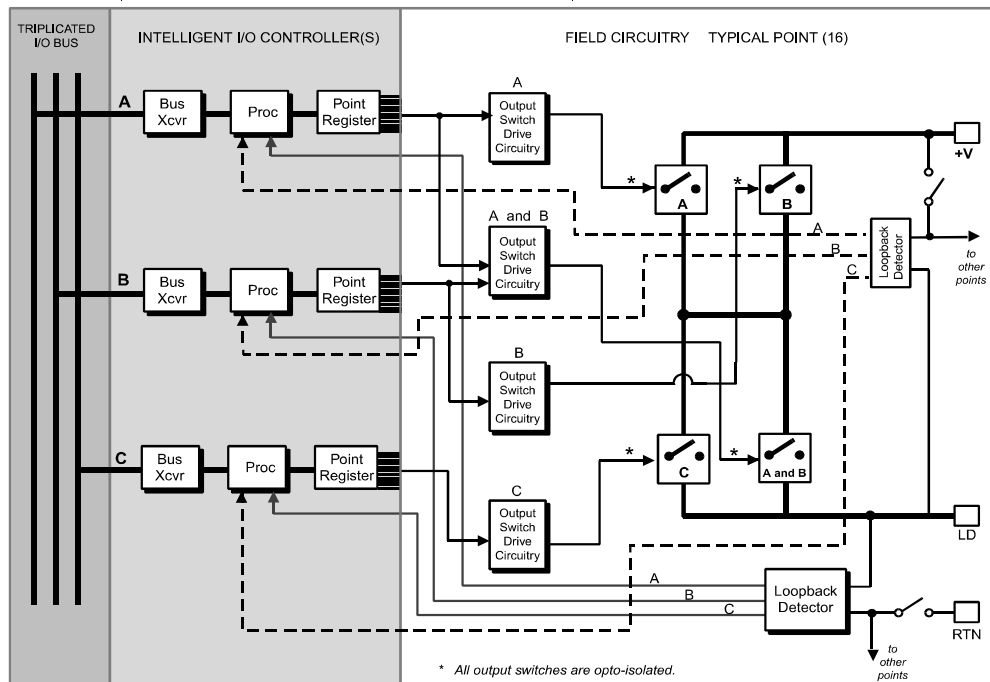

Architecture of 16-Point Supervised Digital Output Module

paragraphs described digital output modules in general, followed by specifics for the four types.

Every digital output module houses the circuitry for three identical, isolated channels. Each channel includes an I/O micro-processor which receives its output table from the I/O communication processor on its corresponding main processor. All of the digital output modules, except the dual DC modules, use special quadruplicated output circuitry which votes on the individual output signals just before they are applied to the load. This voter circuitry is based on parallel-series paths which pass power if the drivers for channels A and B, or channels B and C, or channels A and C command them to close—in other words, 2-out-of-3 drivers voted ON. The quadruplicated voter circuitry provides multiple redundancy for all critical signal paths, guaranteeing safety and maximum availability.

Each type of digital output module executes a particular Output Voter Diagnostic (OVD) for every point. Loop-back on the module allows each microprocessor to read the output value for the point to determine whether a latent fault exists within the output circuit.

Analog Input Modules

On an analog input module, each of the three channels asynchronously measures the input signals and places the results into a table of values. Each of the three input tables is passed to its associated main processor module using the corresponding I/O bus. The input table in each main processor module is transferred to its neighbors across the Tricon. The middle value is selected by each main processor, and

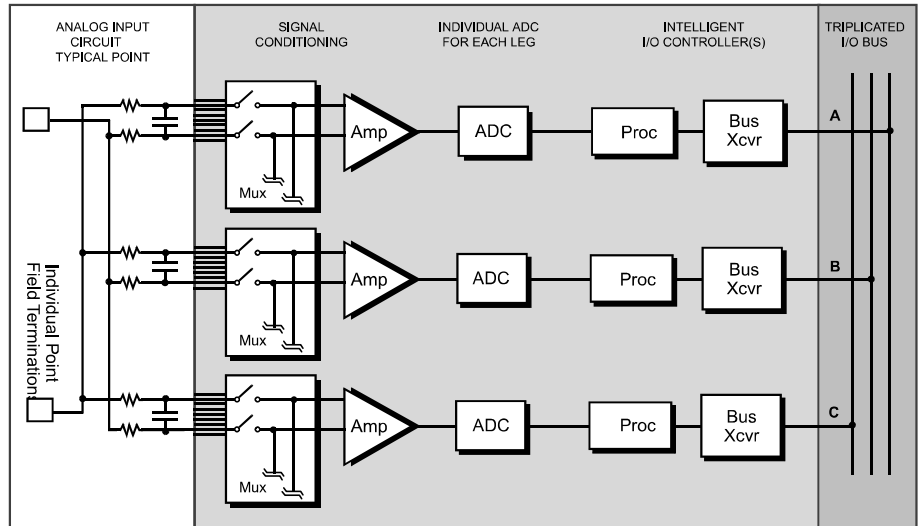

Architecture of TMR Analog Input Module

the input table in each main processor is corrected accordingly. In TMR mode, the mid-value data is used by the control program; in duplex mode, the average is used.

Each analog input module is automatically calibrated using multiple reference voltages read through the multiplexer. These voltages determine the gain and bias that are required to adjust readings of the analog-to-digital converter (ADC).

Analog input modules and termination panels are available to support a wide variety of analog inputs, in both isolated and non-isolated versions: 0-5 VDC, -5 to +5 VDC, 0-10 VDC, 4-20 mA, thermocouples (types K, J, T, E), and Resistive Thermal Devices (RTDs).

Analog Output Module

The analog output module receives three tables of output values, one for each channel from the corresponding main processor. Each channel has its own digital-to-analog converter (DAC). One of the three channels is selected to drive the analog outputs. The output is

continuously checked for correctness by “loop-back” inputs on each point which are read by all three microprocessors. If a fault occurs in the driving channel, that channel is declared faulty and a new channel is selected to drive the field device. The designation of “driving channel” is rotated among the channels, so that all three channels are tested.

Field Terminations

Various termination options are available for field wiring of the Tricon chassis, including external termination panels (ETPs) and fanned-out cables.

An ETP is an electrically-passive printed circuit board to which field wiring is easily attached. An ETP passes input signals from the field to an input module or passes signals generated by an output module directly to field wiring, thereby permitting removal or replacement of the input or output module without disturbing field wiring.

A fanned-out cable is a lower-cost alternative to an ETP when using digital

Theory of Operation

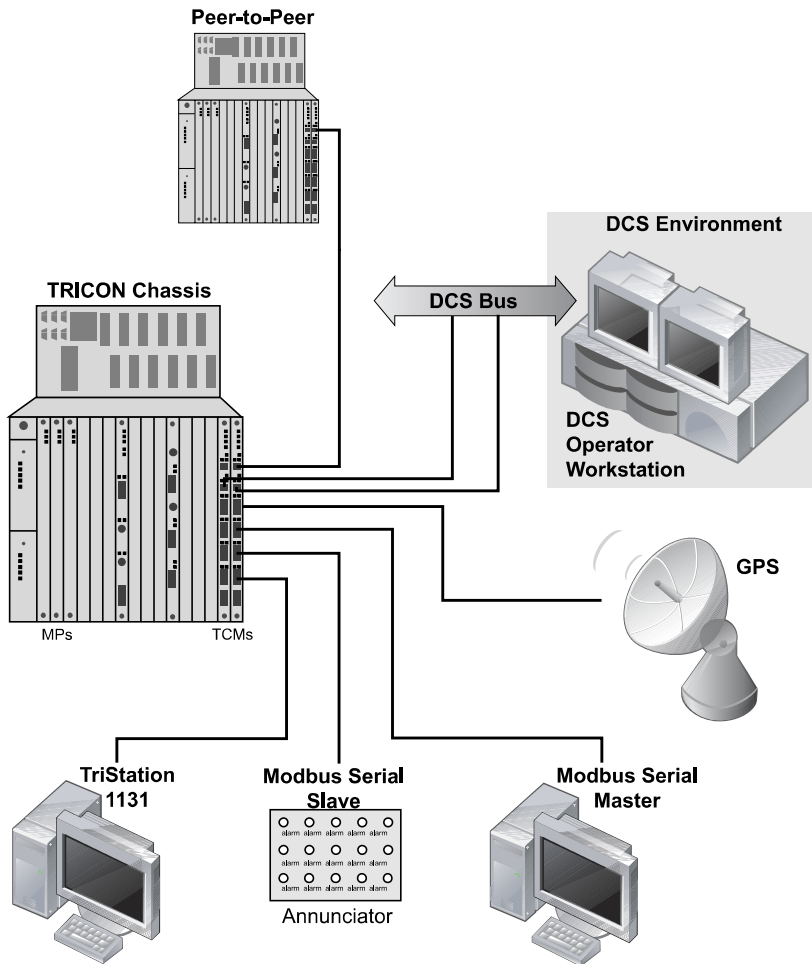

Sample of the TCM Communication Capabilities

input or digital output modules. One end of a fanned-out cable connects to the Tricon backplane and the other end provides 50 fanned-out leads, each individually labeled with a pin number that matches the connector signals.

Communication Modules

By means of the communication modules described in this section, the Tricon can interface with Modbus masters and slaves, other Triconex controllers in a Triconex peer-to-peer network, external hosts on Ethernet networks, and Honeywell and Foxboro

distributed control systems (DCS). The main processors broadcast data to the communication modules across the communication bus. Data is typically refreshed every scan; it is never more than two scan-times old. For more information, see [“Communication Capabilities”](#) on page 59.

Tricon Communication Module (TCM)

The Tricon Communication Module (TCM) enables a Tricon controller to communicate with Modbus devices (masters or slaves), a TriStation PC, a network printer, other Triconex control-

lers, and other external devices on Ethernet networks.

Each TCM has four serial ports, two Ethernet network ports, and one debug port (for Triconex use).

A single Tricon controller supports up to four TCMs, which reside in two logical slots. This arrangement provides a total of sixteen serial ports and eight Ethernet network ports.

Enhanced Intelligent Communication Module (EICM)

Supports RS-232, RS-422, and RS-485 serial communication with external devices at speeds up to 19.2 kilobits per second. The EICM provides four serial, opto-isolated ports which can interface with Modbus masters, slaves, or both; or a TriStation. The module also provides a Centronics-compatible parallel port.

Network Communication Module (NCM)

The NCM supports Ethernet (802.3) communication at 10 megabits per second for Triconex-proprietary protocols and applications.

The NCM also supports OPC Server which can be used by any OPC client. In addition, users can write their own applications using the TSAA protocol.

The NCMG enables time synchronization to a GPS device.

Hiway Interface Module (HIM)

The HIM acts as an interface between a Tricon controller and a Honeywell TDC 3000 Distributed Control System (DCS) by means of the Hiway Gateway and Local Control Network (LCN). The HIM enables higher-order devices, such as computers and operator workstations, to communicate with the Tricon.

Safety Manager Module (SMM)

The SMM acts as an interface between a Tricon controller and a Honeywell Universal Control Network (UCN), one of three principal networks of the TDC 3000 DCS. The SMM appears to the TDC 3000 as a safety node on the Universal Control Network (UCN), allowing the Tricon to manage process-critical points within the overall TDC 3000 environment. The SMM transmits all Tricon aliased data and diagnostic information to TDC 3000 operator workstations in display formats that are familiar to Honeywell operators.

Advanced Communication Module (ACM)

The ACM acts as an interface between a Tricon controller and a Foxboro Intelligent Automation (I/A) Series DCS. The ACM appears to the Foxboro system as a safety node on the I/A Series Nodebus, allowing the Tricon to manage process-critical points within the overall I/A DCS environment. The ACM transmits all Tricon aliased data and diagnostic information to I/A operator workstations in display formats that are familiar to Foxboro operators.

See “Product Specifications” on page 17 for specifications of the TCM, EICM, NCM, SMM, HIM, and ACM.

Power Supply Modules

Each Tricon chassis houses two power modules arranged in a dual-redundant configuration. Each module derives power from the backplane and has independent power regulators for each channel. Each can support the power requirements for all the modules in the chassis in which it resides, and each feeds a separate power rail on the chassis backplane. The power modules have built-in diagnostic circuitry which checks for out-of-range voltages and over-temperature conditions. A short on a channel disables the power regulator rather than affecting the power bus.

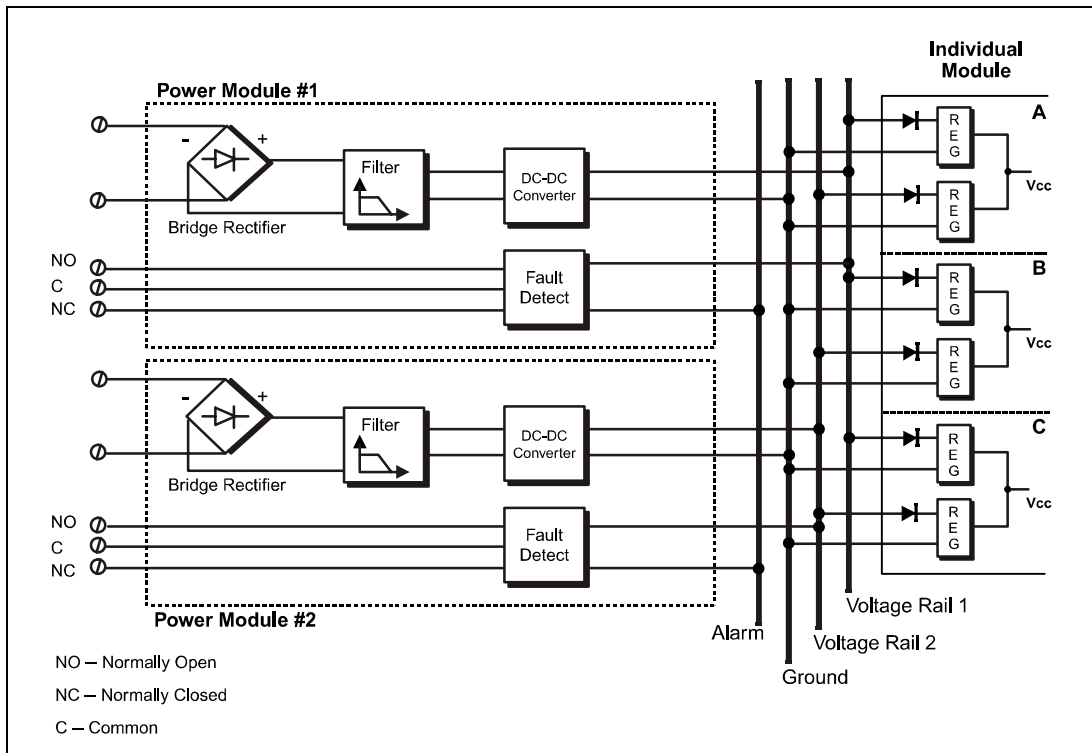

Architecture of Power Subsystem

A Tricon system consists of one main chassis and up to fourteen additional chassis.



System Configuration

A Tricon system is composed of a main chassis and up to 14 expansion or remote expansion (RXM) chassis. The maximum system size is 15 chassis supporting a total of 118 I/O modules and communication modules that interface with OPC clients, Modbus devices, other Tricons, and external host applications on Ethernet (802.3) networks, as well as Foxboro and Honeywell distributed control systems (DCS).

The following sections provide guidelines for chassis layout and system configuration.

Chassis Layout

Two power supplies reside on the left side of all chassis, one above the other. In the main chassis, the three main processors are immediately to the right. The remainder of the chassis is divided into six logical slots for I/O and communication modules and one COM slot with no hot-spare position. Each logical slot provides two physical spaces for modules, one for the active module and the other for its optional hot-spare module.

The layout of an expansion chassis is similar to that of the main chassis, except that expansion chassis provide eight logical slots for I/O modules. (The spaces used by the main processors and the COM slot in the main chassis are now available for other purposes.)

The main and expansion chassis are interconnected by means of triplicated I/O bus cables. The maximum I/O bus cable length between the main chassis

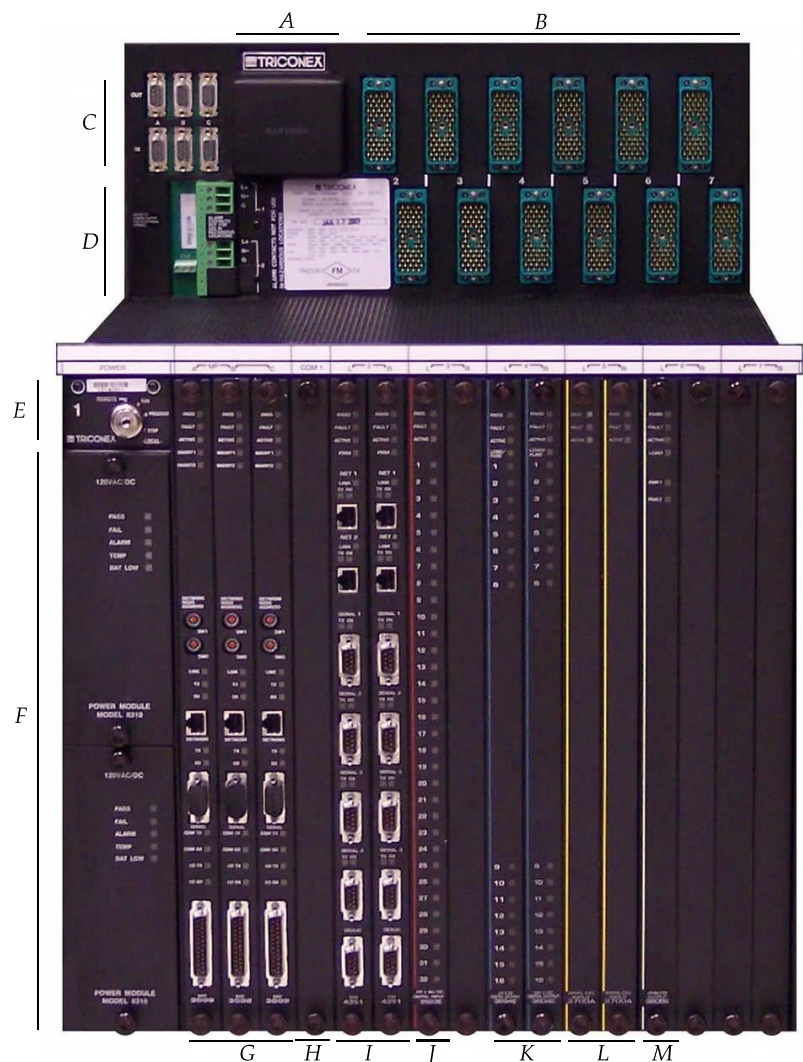

- | | | |
|--------------------------------|----------------------------|-----------------------------|
| A. Memory backup battery | F. Redundant Power Modules | K. DO module with hot-spare |
| B. Connectors for terminations | G. Three Main Processors | L. AI module with hot-spare |
| C. I/O expansion ports | H. COM slot (empty) | M. AO module without spare |
| D. Power terminals | I. Two TCMs | |
| E. Keyswitch | J. DI module without spare | |

Sample Layout of a Tricon Chassis

System Configuration

and the last expansion chassis is normally 100 feet (30 meters), but in restricted applications the length can be up to 1,000 feet (300 meters). (Please consult your Triconex Customer Support representative for assistance when configuring a system that exceeds 30 meters of I/O bus cable length.)

RXM chassis are used for systems in which the total cable distance between the first chassis and the last chassis exceeds the distance which can be supported by copper. Each RXM chassis houses a set of three RXM modules in the same position as the main processors in the main chassis. Six remaining logical slots are available in an RXM chassis and one blank (unused) slot.

Online Module Repair

The logical slot arrangement of a Tricon chassis provides two approaches to the online repair of faulting modules: the *hot-spare* method and *online module replacement*.

With the hot-spare method, a logical slot contains two identical I/O modules. While one module is active, the other module is powered but inactive. The Tricon cycles control between the two healthy I/O modules approximately every hour, so that each undergoes complete diagnostics on a regular basis. If a fault is detected on one module, the Tricon automatically switches control to the other module, allowing the system to maintain three healthy channels continuously. The faulty module can then be removed and replaced.

Alternatively, a module can be replaced online even when only one I/O module is normally installed in a logical slot. If a fault occurs, the Fault indicator turns on, but the module remains active on two channels. A replacement module is then inserted into the unused space in the slot. The Tricon will grant control to this second I/O module after it passes a diagnostic test. Once the replacement I/O module becomes active, the faulty module can be removed. This repair method demonstrates the Tricon controller's ability to automatically transition from triplicated to dual

control and back again without process interruption.

A Tricon system should include at least one hot-spare module in place for each type of I/O module in the system. With this arrangement, hot-spare modules are tested regularly and can be used for online module replacement anywhere in the system.

I/O Bus Connections

The figure on this page shows the three sets of RS-485 I/O bus ports (IN and OUT) on each chassis. Additional chassis may branch out from the main chassis by means of the I/O bus ports, up to a maximum of 14. There are six ports—two sets of three for triplicated serial communication — located on a panel in the upper left corner of the backplane. One set of three I/O bus cables is required for each expansion chassis, and for each RXM chassis that houses a primary RXM module set. (Remote RXM chassis are connected to the primary RXM chassis with fiber-optic cables.) Communication across the I/O bus cables (and the RXM fiber-optic cables) is at 375 kilobits per second, the same rate as the internal I/O bus on the backplane of each chassis.

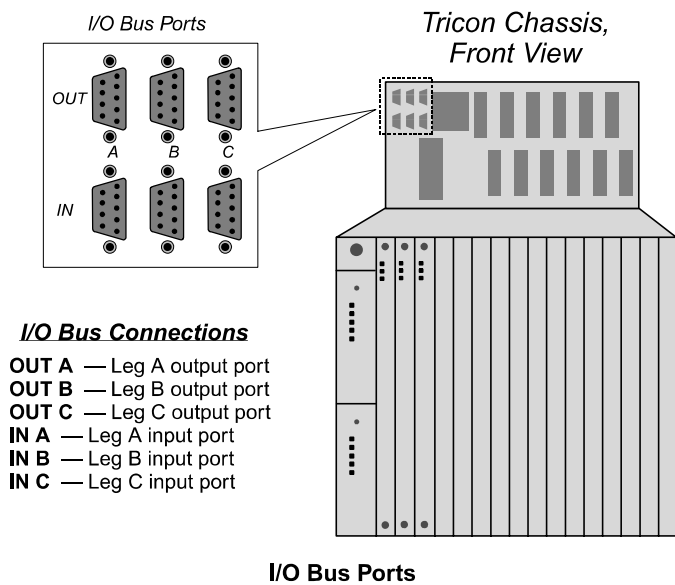

System Configuration Guidelines

A Tricon system must have a main chassis and may have up to 14 expansion or remote expansion (RXM) chassis. The following configuration guidelines apply.

Main Chassis Configuration Guidelines

- There is one main chassis with a chassis address of 1.
- The main chassis must contain three model 3008 Main Processors for Tricon v9.6 and later systems.
- The main chassis must house two power modules.
- The main chassis provides six logical slots for user-selected modules and one COM slot.
- A v9 low-density configuration includes a v5–v8 chassis with v9 main processors, communication, and I/O modules.

Expansion Chassis Configuration Guidelines

- Expansion chassis are used when the total I/O bus cable length for the system is less than 100 feet (30 meters) for each channel.
- Each expansion chassis must have a unique address between 2 and 15. This address must not be used by any other chassis.
- Each expansion chassis must house two power modules.
- One set of triplicated I/O bus cables is used to interconnect channels A, B and C between expansion chassis.
- Each expansion chassis provides eight logical slots.

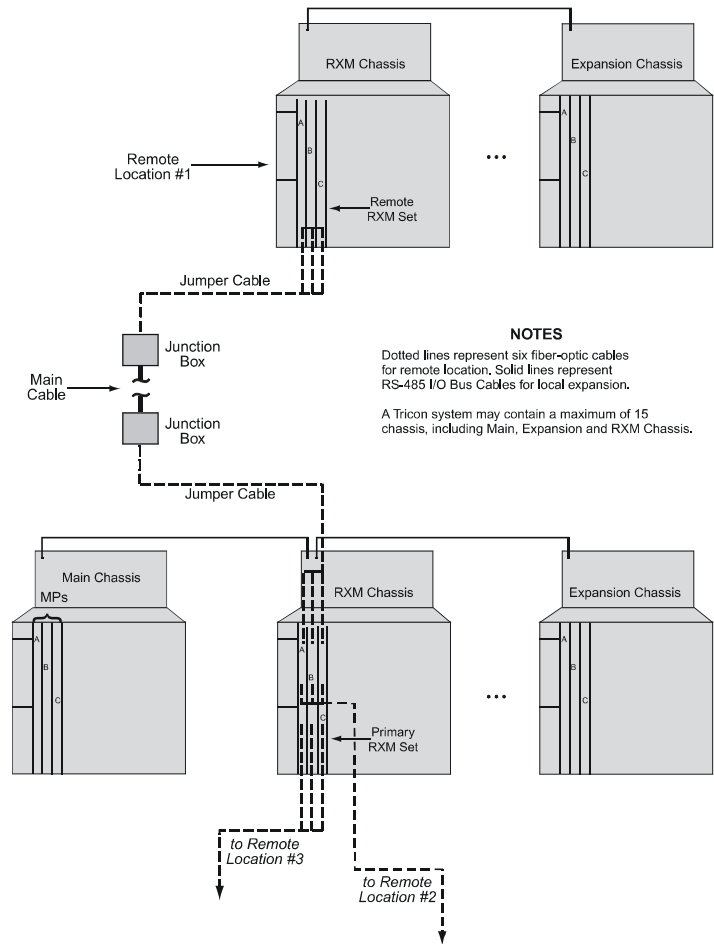

System Configuration with Three Remote Locations

RXM Chassis Configuration Guidelines

- RXM chassis must be used when the total I/O bus cable length for the system is greater than 100 feet (30 meters) for each channel.
- Each RXM chassis must have a unique address between 2 and 15. This address must not be used by any other chassis.
- One RXM chassis must be located within 100 feet (30 meters) of the main chassis. This RXM chassis must house the primary RXM module set. Up to 3 primary RXM module sets are normally supported.

Contact Triconex regarding other configurations.

- Each primary RXM module set can support up to 3 remote sites, each up to 7.5 miles (12 kilometers) away.
- One RXM chassis must be located at each remote site. This RXM chassis must house a remote RXM module set.
- A primary RXM module set and a remote RXM module set are connected by 6 fiber-optic cables which transmit and receive signals for channels A, B and C.

System Configuration

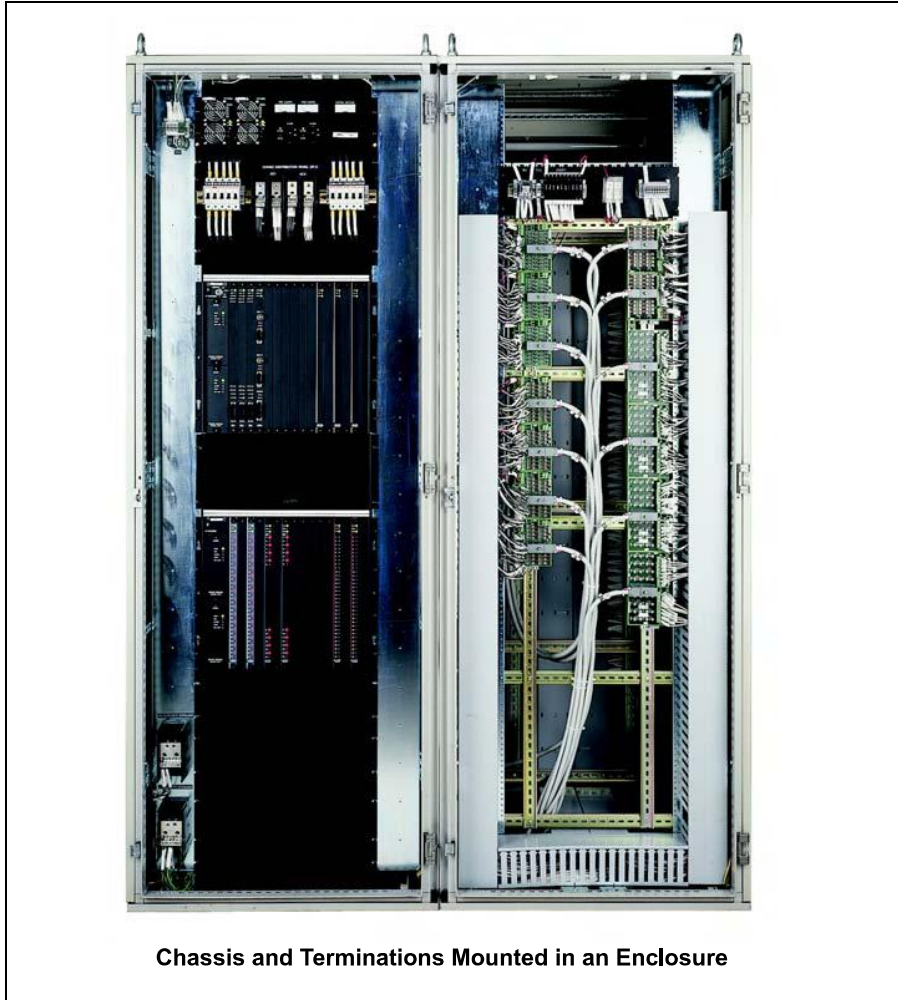

- RXM chassis can be connected to local expansion chassis using I/O bus cables.
- Each RXM chassis must contain 2 power modules.
- Each RXM chassis provides 6 logical slots for I/O modules and 1 blank (unused) slot.

Communication Module Configuration Guidelines

The following rules apply to the TCM, EICM, NCM, HIM, SMM, and ACM in a Tricon system:

- A TriStation PC communicates with a Tricon controller through a TCM, EICM, NCM or ACM, so at least one of these modules must be installed in the main chassis or Chassis 2.
- One logical slot is available for EICMs or ACMs, respectively. Matched pairs of these modules can be installed in both the left and right positions of one logical slot.
- Up to two logical slots can be configured for NCMs. Matched pairs of NCMs can be installed in the left and right positions of each logical slot. If only one logical slot is used, the slot can be in the main chassis or Chassis 2. If two logical slots are used, they must be Slot 6 and 7 in the main chassis, and peer-to-peer cannot be used.
- Up to two logical slots can be configured for TCMs. Matched pairs of TCMs can be installed in the left and right positions of each logical slot, and they can be located in the main chassis or Chassis 2.

- Up to three logical slots can be configured for SMMs. A matched pair of SMMs can be installed in the left and right positions of each logical slot. All three slots must be in the main chassis or Chassis 2.
- Up to two logical slots can be configured for HIMs. Both slots must be in the main chassis.
- The COM slot can be configured only for the EICM, TCM or NCM.
- You cannot install an NCM and a TCM in the same Tricon system. You also cannot install an EICM and a TCM in the same system.
- If communication modules are housed in Chassis 2, this chassis must be connected directly to the main chassis using I/O COMM cables (model 9001) rather than standard I/O bus cables.
- Chassis 2 can be an I/O expansion chassis or a primary RXM chassis.

Chassis Power Limitations

To maintain the safety and reliability of the Tricon, each system must be configured for operation under a worst-case scenario. These circumstances include operation with only one functional power supply at 140°F (60°C), ambient. (See [“Power Modules” on page 24](#) for detailed specifications). Under these conditions, the power supply is rated to deliver 175 watts. The table to the right lists the logic power consumption per module in watts.

Module Type	Watts Consumed
ACM	15
Analog Input	10
Analog Input, Isolated	15
Analog Input, High Density	10
Analog Output	15
Digital Input, High Density	10
Digital Input, Single	10
Digital Input, TMR	10
Digital Output, AC	10
Digital Output, DC	10
Digital Output, Dual	10
Digital Output, Supervised	15
EICM	10
HIM 10	
Main Processor, model 3008	10
NCM	20
Power Module	n/a
SMM	20
TCM	7
Thermocouple Input, Isolated	15
Thermocouple Input, Non-Isolated	10
Pulse Input	20
Pulse Totalizer	10
RXM	5
Relay Output	15

Tricon I/O Modules

Voltage	Description	Type	Model No.	Points	For Details, See
Digital Input Modules					
115 VAC/VDC	Opto-Isolated, Non-Commoned	TMR	3501E/3501T	32	page 33
48 VAC/VDC	Commoned in Groups of 8, Self-Test	TMR	3502E	32	page 33
24 VAC/VDC	Commoned in Groups of 8, Self-Test	TMR	3503E	32	page 33
24/48 VDC	High Density, DC Coupled	TMR	3504E	64	page 34
24 VDC	Low Threshold with Self-test, Commoned	TMR	3505E	32	page 33
24 VDC	Single, Opto-Isolated, Commoned	Single	3564	64	page 34
Pulse Input	Differential, AC Coupled	TMR	3511	8	page 35
Pulse Totalizer	Opto-isolated, Non-commoned	TMR	3515	32	page 36
Digital Output Modules					
115 VAC	Opto-Isolated, Non-commoned	TMR	3601E/3601T	16	page 37
120 VDC	Opto-Isolated, Non-commoned Opto-Isolated, Commoned	TMR	3603B, 3603E/3603T	16	page 37
24 VDC	Opto-Isolated, Non-commoned	TMR	3604E	16	page 37
48 VDC	Opto-Isolated, Non-commoned	TMR	3607E	16	page 37
115 VAC	Galvanically Isolated, Commoned., Supv.	TMR	3611E	8	page 39
48 VDC	Galvanically Isolated, Commoned, Supv.	TMR	3617E	8	page 39
120 VDC	Opto-Isolated, Commoned, Supervised	TMR	3623/3623T	16	page 38
24 VDC	Opto-Isolated, Commoned, Supervised	TMR	3624	16	page 38
24 VDC	Supervised/Non-Supervised, Commoned	TMR	3625	32	page 38
24 VDC	Opto-Isolated, Commoned	Dual	3664	32	page 40
24 VDC	Opto-Isolated, Commoned	Dual	3674	32	page 40
Relay Output	Non-triplicated, Normally Open	Non-triplicated	3636R/3636T	32	page 35
Analog Input Modules					
0-5 VDC	Differential, DC Coupled	TMR	3700A	32	page 41
0-10 VDC	Differential, DC Coupled	TMR	3701	32	page 41
0-5, 0-10 VDC	Differential, Isolated	TMR	3703E	16	page 41
0-5, 0-10 VDC	High-Density, Differential, DC Coupled	TMR	3704E	64	page 41
Thermocouple	Differential, DC Coupled	TMR	3706A	32	page 44
Thermocouple	Differential, Isolated	TMR	3708E	16	page 44
0-5 VDC	Single-Ended	TMR	3720	64	page 41
0 to 5 or -5 to +5 VDC	Differential, DC Coupled	TMR	3721	32	page 41
Analog Output Modules					
4-20 mA	Current Loop, DC Coupled	TMR	3805E	8	page 43
4-20 mA and 20-320 mA	Current Loop, DC Coupled	TMR	3806E	6 and 2	page 43

Product Specifications

Model Number	3704E	3720	3721
Voltage	0-5V or 0-10V ¹ , + 6%	0-5VDC, + 6%	0 to 5 VDC or -5 to +5 VDC ¹ , + 6%
Type	TMR	TMR	TMR
No. of Input Points	64, commoned	64, single-ended	32 differential, DC-coupled
Isolated Points	No	Yes	Yes
Input Update Rate	75 ms	10 ms	10 ms
Resolution	12 bits	12 bits or 14 bits programmable	12 bits or 14 bits programmable
Accuracy	< 0.25% of FSR from 0° to 60°C	< 0.15% of FSR from 0° to 60° C	< 0.15% of FSR from 0° to 60° C
Input Resistance (load)	30 MΩ(DC), min.	10 MΩ(DC), min.	10 MΩ(DC), min.
Power-Off Resistance	30 kΩ(DC), typical	140 kΩ(DC), typical	140 kΩ(DC), typical
Common Mode Rejection	n/a	n/a	-85 dB (DC - 100 Hz)
Common Mode Range	n/a	n/a	-12V to +12V peak
Leg-to-Leg Isolation	200 kΩ typical	420 kΩ typical	420 kΩ typical
Normal Mode Rejection	-1 dB @ 8Hz -12 dB @ 60Hz -18 dB @ 120Hz	-3 dB @ 8Hz -17 dB @ 60Hz -23 dB @ 120Hz	-3 dB @ 23 Hz -8 dB @ 60 Hz -14 dB @ 120 Hz
Input Overrange Protection	150 VDC/115 VAC continuous	150 VDC/115 VAC continuous	150 VDC/115 VAC continuous
Current Range	0-20 mA, 250 Ω shunt for 5V 500 Ω shunt for 10V	0-20 mA (plus 6% over-range) with 250 Ω shunt resistor	0-20 mA with 250 Ω shunt resistor
Diagnostic Indicators			
Module Status	PASS, FAULT, ACTIVE	PASS, FAULT, ACTIVE, FIELD	PASS, FAULT, ACTIVE, FIELD
Color Code	Copper	Yellow	Yellow

1. The voltage is selected using the TriStation software.

Module Part #	Module Description	Upscale	Downscale	Basic Term Panels	Nonincendive Term Panels	Fanned-out Cables	Bypass Panels	ERT Loop-Back Cables/Panels
3706A	Thermocouple input, type J, K, T, differential, 32 pts.	9766-210	9766-510	n/a	9784-610, upscale 9785-610, downscale	n/a	n/a	n/a
3708E	Thermocouple input, type E, J, K, T, isolated, 16 pts.	9765-610	9765-610	n/a	9786-110	n/a	n/a	n/a
Module Part #	Module Description	3-Wire 4-20 mA	Voltage	2-Wire 4-20 mA	Nonincendive Term Panels	Basic	RTD/TC/AI	
3700 3700A	AI, 0–5 VDC, differential, 32 pts.	n/a	9763-810	9761-210, 0–5 V 9771-210, 0–5 V	9791-610, current input 9787-110, voltage input	9753-110, 0–5 V	9764-310 ¹	
3701	AI, 0–10 VDC, differential, 32 pts.	n/a	9763-810	9761-410	n/a	9753-110, 0–10 V	n/a	
3703E ²	AI, 0–5/0–10 VDC, isolated, 16 pts.	n/a	9763-810	9762-210, 0–5 V 9762-410, 0–10 V 9771-210, 0–5 V	9791-610, current input 9787-110, voltage input	9753-110, 0–5/0–10 V	n/a	
3704E ²	AI, 0–5/0–10 VDC, non-isolated, 64 pts.	9765-210, 0–5V	n/a	9760-210, 0–5 V 9760-410, 0–10 V	9789-610, 4–20 mA	9750-210, 4–20 mA 9750-810, 0–5/0–10 V	n/a	
3720	AI, 0–5 VDC, single-ended, 64 pts.	9765-210, 0–5 V	n/a	9760-210, 0–5 V 9760-410, 0–10 V	9789-610, 4–20 mA	9750-210, 4–20 mA 9750-810, 0–5/0–10 V	n/a	
3721 ²	AI; 0 to 5 VDC or –5 to +5 VDC; differential; 32 pts.	n/a	9763-810	9761-210, 0–5 V 9761-410, 0–10 V 9771-210, 0–5 V	9791-610, current input 9787-110, voltage input	9753-110, 0–5 V	n/a	

1. Signal conditioners must be ordered separately. A total of 16 is required for each termination panel.
2. Must be configured with TriStation.

Dimensions of External Termination Panels

Panel Model	Width (across DIN rail)	Length (along DIN rail)	Height (out from DIN rail)
9251-210	7 in (17.78 cm)	19 in (48.26 cm)	4.75 in (12.065 cm)
9551-110	3 in (7.62 cm)	5 in (12.7 cm)	4.25 in (10.795 cm)
9552-610	3 in (7.62 cm)	5 in (12.7 cm)	4.25 in (10.795 cm)
9553-610	3 in (7.62 cm)	5 in (12.7 cm)	4.25 in (10.795 cm)
9561-110	4.5 in (11.43 cm)	7.75 in (19.685 cm)	4.25 in (10.795 cm)
9561-810	4.5 in (11.43 cm)	5 in (12.7 cm)	4.25 in (10.795 cm)
9562-810	4.5 in (11.43 cm)	5 in (12.7 cm)	4.25 in (10.795 cm)
9563-810	4.5 in (11.43 cm)	5 in (12.7 cm)	4.25 in (10.795 cm)
9563-910	4.5 in (11.43 cm)	5 in (12.7 cm)	4.25 in (10.795 cm)
9565-710	4.5 in (11.43 cm)	10 in (25.4 cm)	4.25 in (10.795 cm)