



System 57
5701 Control System

CHAPTER 2 - SYSTEM DESCRIPTION

4. SINGLE CHANNEL CONTROL CARDS

4.1 General

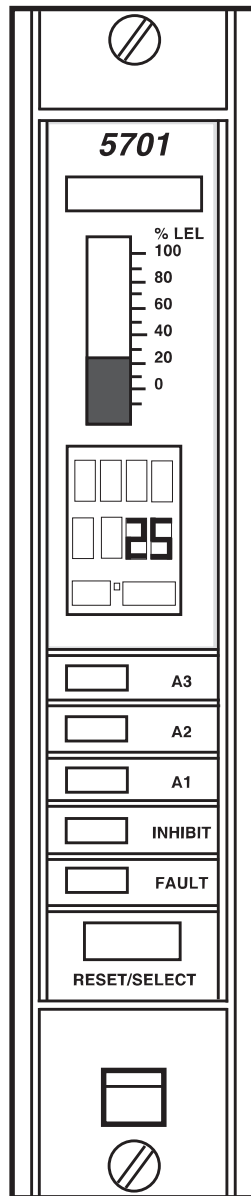

The 5701 Single Channel Control Card provides control, display and alarm facilities for a connected gas detector. The front panel display indicates the gas reading and channel status while LEDs are used for alarms. A push-button is provided for resetting the alarms and selecting the card for use with the Engineering Card.

The operation of the control card is microprocessor controlled and is fully definable for a wide range of connected gas detectors and application requirements. The software configuration setup is stored in an EEPROM.

There are two types of control card depending on the type of gas detector being fitted to the system:

- a. Single Channel Control Card 4 - 20mA.
Part Number 05701-A-0301.
- b. Single Channel Control Card Catalytic.
Part Number 05701-A-0302.

Each of the above control cards consist of a single channel control card fitted with the respective plug-in sensor drive module.

An optional Analogue Output Module can also be plugged into the single channel control card to provide a remote output of the channel card readings.

CHAPTER 2 - SYSTEM DESCRIPTION

4.2 Single Channel Control Card

The Single Channel Control Card carries out the control functions for a single loop of gas detection as follows:

- a. Processes the incoming sensor drive module signal.
- b. Displays the signal level on the front panel liquid crystal display.
- c. Compares the signal level with pre-defined alarm limits.
- d. When the pre-defined alarm limits are exceeded, raises the alarms by lighting up front panel LEDs and operating optional connected relays.
- e. Informs other cards with the alarm status information.
- f. Self validates the operation of its circuit components, software operation and the condition of the sensor.

4.3 Sensor Drive Modules

Two sensor drive modules are provided:

- a. Sensor Drive Module, 4 - 20mA, Part Number 05701-A-0283
- b. Sensor Drive Module Catalytic, Part Number 05701-A-0284

The Sensor Drive Module conditions the incoming catalytic or 4 - 20mA sensor signal and provides the necessary sensor power supply. It contains all the circuitry necessary to generate the voltages and currents required to drive the sensor, the circuitry to acquire the sensor signal and to scale the sensor signal to a standard output. The sensor drive modules are factory fitted and plug directly onto the channel control card.

4.4 Analogue Output Module

An optional Analogue Output Module, (Part Number 05701-A-0285), may be factory fitted to the Single Channel Control Card and is used on a channel of gas detection to provide an isolated current loop output which follows the sensor signal level. This may be set electronically to produce a 0 - 20mA output or a 4 - 20mA output and can be used to operate a chart recorder, etc.

CHAPTER 4 - INSTALLATION INSTRUCTIONS

The sensor cable screen or steel wire armour (or braid), as appropriate, should be connected to the system (protective) earth. This can be achieved where the cable enters the cabinet by using a metal cable gland, or by other suitable means, and avoiding any screen 'tails' within the cabinet.

Where the cable consists of a separate screen sheath and wire armour (or braid), the armour should be connected, at the cabinet entry, to the protective earth and the screen sheath should be connected to the GROUND terminal of the Field Interface/Relay Card or to a suitable instrument earth point.

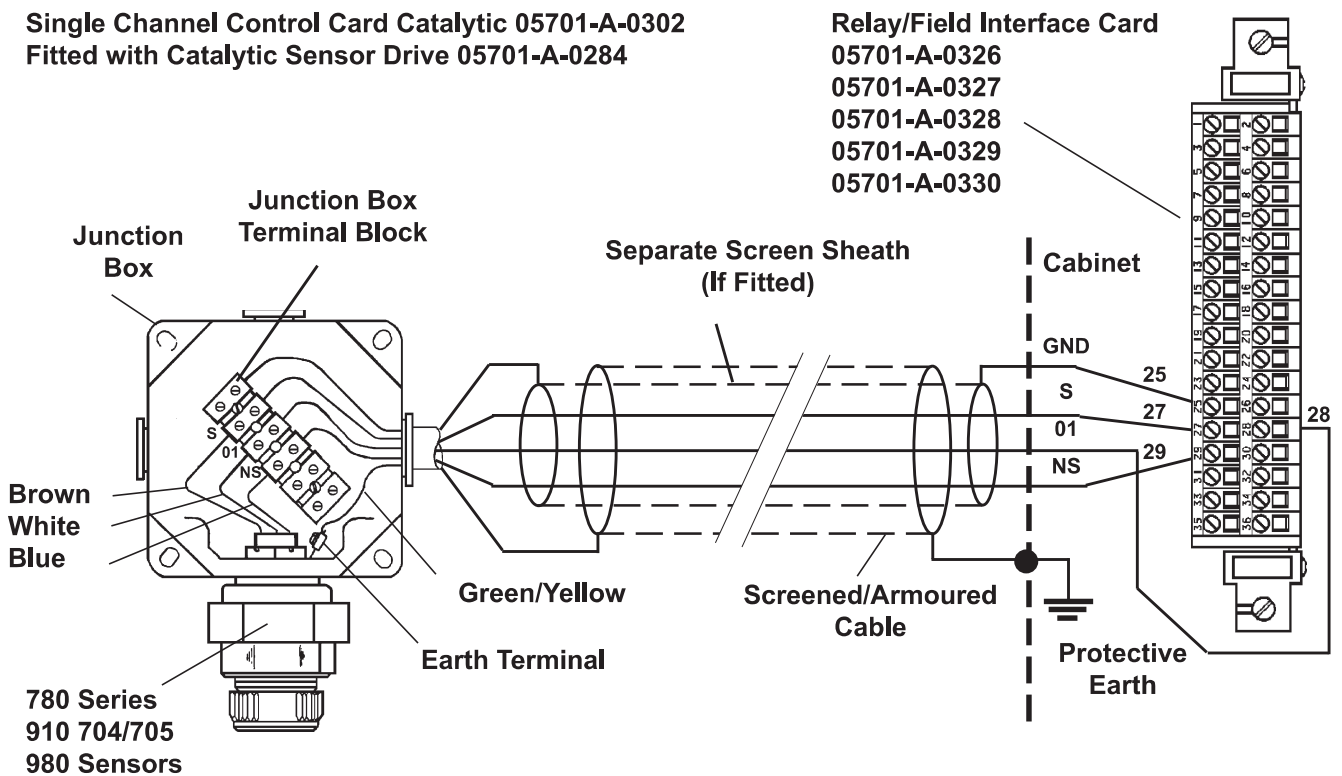

Note: Where a sensor is earthed locally, either to the Earth Stud or through the sensor casing or mounting, to avoid earth loops the screen sheath of the cable should only be connected at one end, i.e., at the sensor or at the Interface/Relay Card.

Combustible Sensor, Junction Box and Terminal Block Connections

CHAPTER 4 - INSTALLATION INSTRUCTIONS

Single Channel Control Card Catalytic 05701-A-0302 Fitted with Catalytic Sensor Drive 05701-A-0284

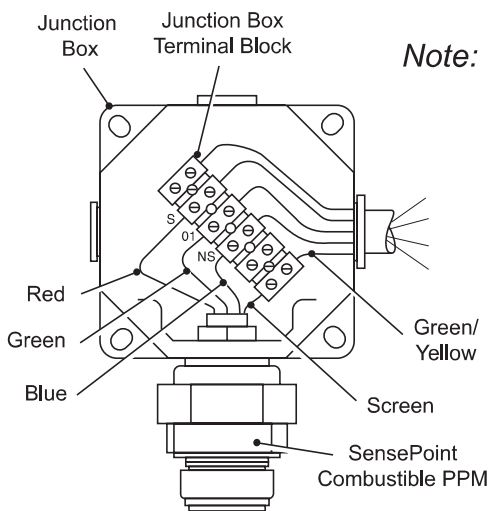
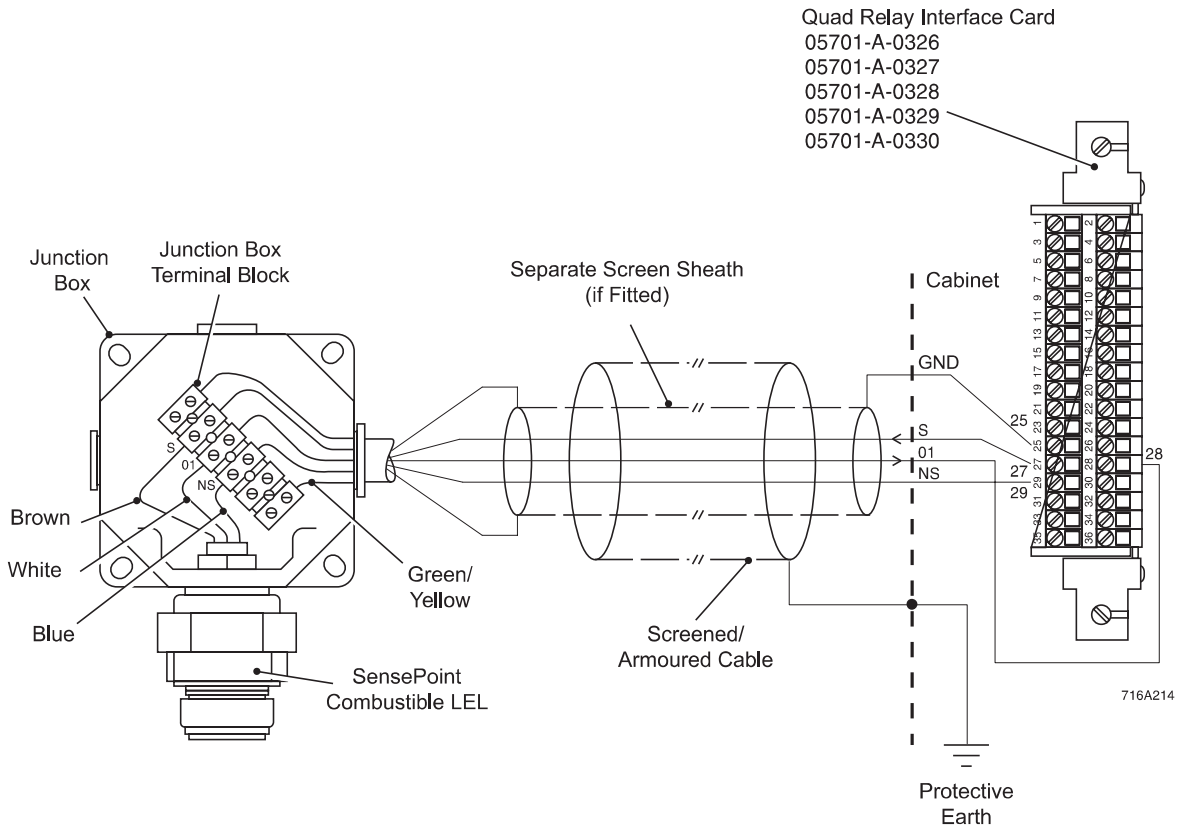

Note: Where a sensor is earthed locally, either to the Earth Stud or through the sensor casing or mounting, to avoid earth loops the screen sheath of the cable should only be connected at one end, i.e., at the sensor or at the Interface/Relay Card.

SensePoint Combustible Sensor, Junction Box and Terminal Block Connections

CHAPTER 4 - INSTALLATION INSTRUCTIONS

The alarm relays may be configured for either normally de-energised or normally energised operation. Check the configuration sheet supplied with the system to determine the operating mode of the relays on each channel. The energisation mode of the relays can be reconfigured easily using a computer attached to the Engineering Port. Contact Honeywell Analytics or your local agent for more information.

14.2 Analogue Output



CAUTION

Connecting the analogue output to a loop voltage in excess of 40V may cause permanent damage to the analogue output module.

The Analogue Output Module provides an isolated current loop output that follows the sensor signal level. The output circuit is a passive current control element that can be operated with loop voltages up to 40V. The recommended connections are shown below:

The analogue output can be configured for 0 - 20mA or 4 - 20mA

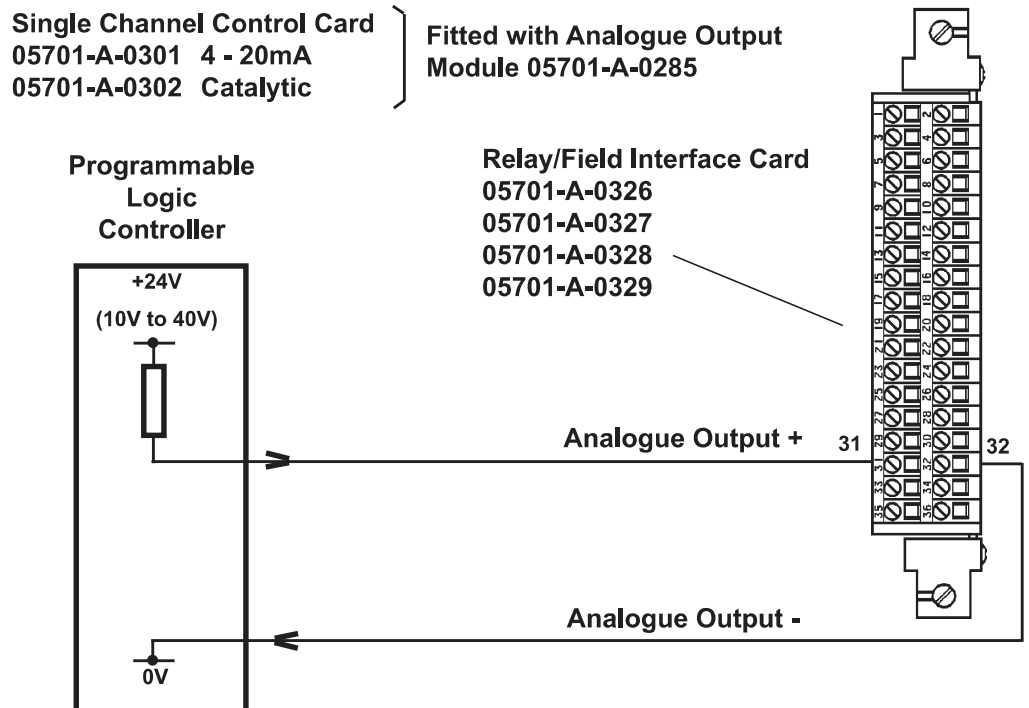

Isolated Analogue Output Connection with Power Sourced from Programmable Logic Controller

CHAPTER 4 - INSTALLATION INSTRUCTIONS

output modes. Check the configuration sheet supplied with the system to determine the factory configured operating mode. The operating mode can be reconfigured easily using a computer attached to the Engineering Port. Contact Honeywell Analytics or your local agent for more information.

The analogue output can be connected to voltage input device (eg. chart recorders) by including an external sense resistor in series with the loop and connecting the device input in parallel with the resistor. ie. Use a 100 ohm resistor and select an input range of 2V on the chart recorder.

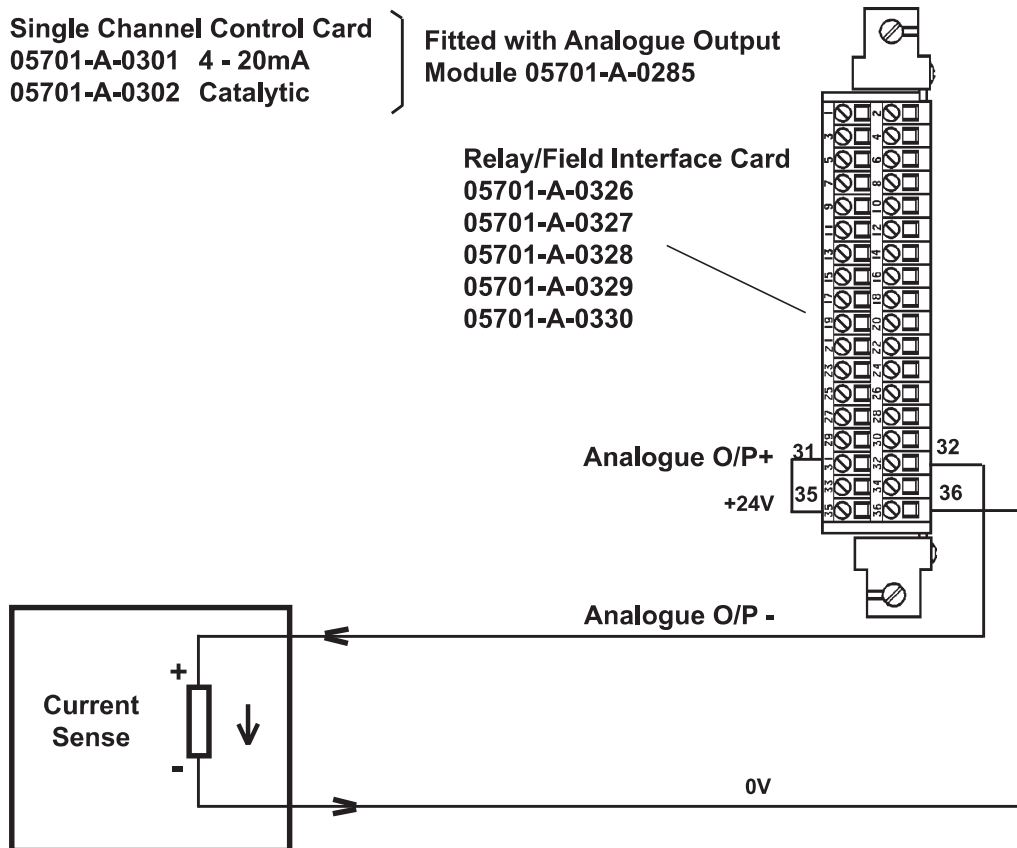

Non-isolated Analogue Output Connection with Power from System 57.

CHAPTER 4 - INSTALLATION INSTRUCTIONS

Single Channel Control Card
05701-A-0301 4 - 20mA
05701-A-0302 Catalytic

Fitted with Analogue Output
Module 05701-A-0285

Relay/Field Interface Card
05701-A-0326
05701-A-0327
05701-A-0328
05701-A-0329
05701-A-0330

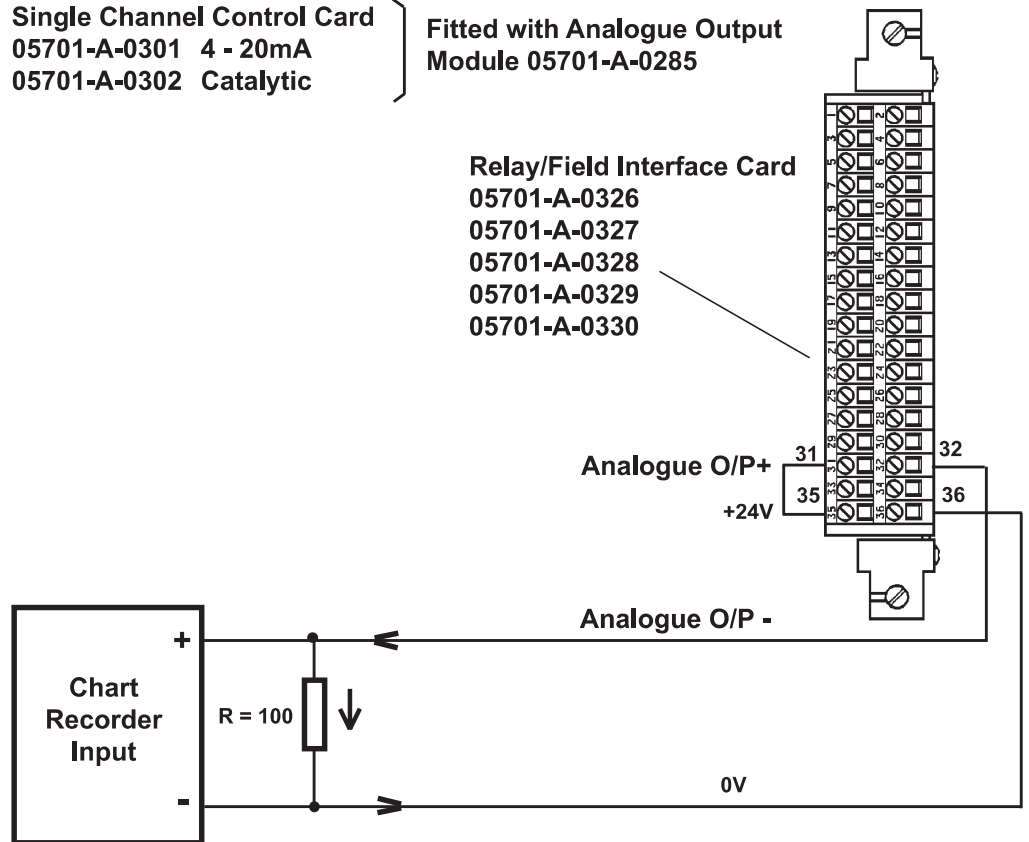

Analogue Output Connection with 100 Ohm Sense Resistor and Parallel Chart Recorder

CHAPTER 4 - INSTALLATION INSTRUCTIONS

15. REMOTE INPUT CONNECTIONS



CAUTION

Connecting voltages in excess of 32V to the remote inputs may cause permanent damage to the Single Channel Control Card.

There are two remote inputs, RESET and INHIBIT, which are individually configurable for active high or active low operating modes. Check the configuration sheet supplied with the system to determine the factory configured operating modes. The operating mode can be reconfigured easily using a computer attached to the Engineering Port. Contact Honeywell Analytics or your local agent for more information.

The switching level of the remote input pins (when enabled) is approximately +2V with respect to the dc system 0V. The inputs require less than 5mA drive current and irrespective of configuration are internally pulled down to system 0V.

Active high remote inputs may be left unconnected or can be connected to +24V via a normally open contact. The remote input will operate whenever the contact closes.

Active low remote inputs may be connected to +24V via a normally closed contact. The remote input will operate whenever the contact opens. **Do not leave active low inputs unconnected.**

CHAPTER 4 - INSTALLATION INSTRUCTIONS

Single Channel Control Card
05701-A-0301 4 - 20mA
05701-A-0302 Catalytic

Configured for active high remote inputs

Relay/Field Interface Card
05701-A-0326
05701-A-0327
05701-A-0328
05701-A-0329
05701-A-0330

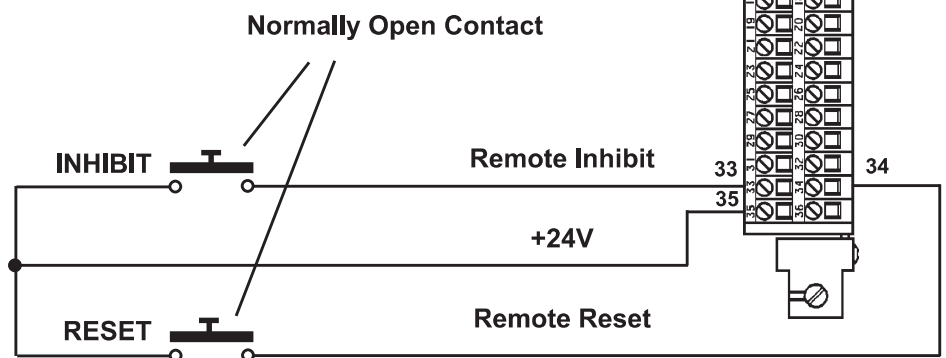

Active High Remote Input Connected via Normally Open Voltage Free Contact to +24V

Single Channel Control Card
05701-A-0301 4 - 20mA
05701-A-0302 Catalytic

Configured for active low remote inputs

Relay/Field Interface Card
05701-A-0326
05701-A-0327
05701-A-0328
05701-A-0329
05701-A-0330

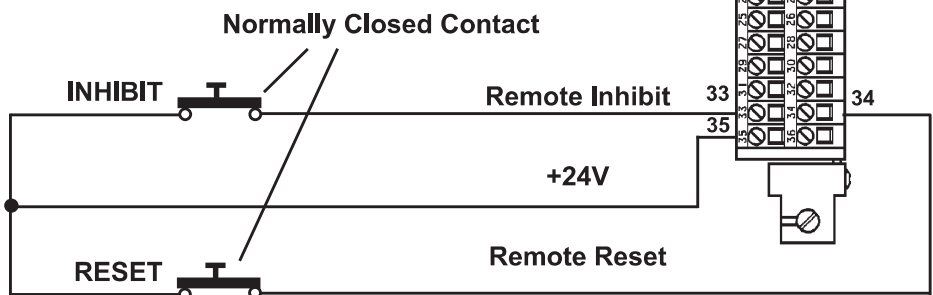

Active Low Remote Input Connected via Normally Closed Voltage Free Contact to +24V