

# 3300 XL 8 mm Proximity Transducer System

## Datasheet

**Cordant™**

141194 Rev. AM



## Description

The 3300 XL 8 mm Proximity Transducer System consists of:

- One 3300 XL 8 mm probe,
- One 3300 XL extension cable<sup>1</sup>, and
- One 3300 XL ProximitoR Sensor<sup>2</sup>.

The system provides an output voltage that is directly proportional to the distance between the probe tip and the observed conductive surface and can measure both static (position) and dynamic (vibration) values. The system's primary applications are vibration and position measurements on fluid-film bearing machines, as well as Keyphasor reference and speed measurements<sup>3</sup>.

The 3300 XL 8 mm system delivers the most advanced performance in our eddy current proximity transducer systems. The standard 3300 XL 8 mm 5-meter system also fully complies with the American Petroleum Institute's (API) 670 Standard for mechanical configuration, linear range, accuracy, and temperature stability. All 3300 XL 8 mm proximity transducer systems provide this level of performance and support complete interchangeability of probes, extension cables, and ProximitoR sensors, eliminating the need to match or bench calibrate individual components.

Each 3300 XL 8 mm Transducer System component is backward compatible and interchangeable<sup>4</sup> with other non-XL 3300 series 5 mm and 8 mm transducer system components<sup>5</sup>. This compatibility includes the 3300 5 mm probe, for applications in which an 8 mm probe is too large for the available mounting space<sup>6,7</sup>.



**Baker Hughes**

## Proximito Sensor

The 3300 XL Proximito Sensor incorporates numerous improvements over previous designs. Its physical packaging allows you to use it in high-density DIN-rail installations. You can also mount the sensor in a traditional panel mount configuration, where it shares an identical 4-hole mounting "footprint" with older Proximito Sensor designs. The mounting base for either option provides electrical isolation and eliminates the need for separate isolator plates. The 3300 XL Proximito Sensor is highly immune to radio frequency interference, allowing you to install it in fiberglass housings without adverse effects from nearby radio frequency signals. The 3300 XL Proximito Sensor's improved RFI/EMI immunity satisfies European CE mark approvals without requiring special shielded conduit or metallic housings, resulting in lower installation costs and complexity.

The 3300 XL's SpringLoc terminal strips require no special installation tools and facilitate faster, more robust field wiring connections by eliminating screw-type clamping mechanisms that can loosen.

## Proximity Probe and Extension Cable

The 3300 XL probe and extension cable also reflect improvements over previous designs. A patented TipLoc molding method provides a more robust bond between the probe tip and the probe body. The probe's cable incorporates a patented CableLoc design that provides 330 N (75 lbf) pull strength to more securely attach the probe cable and probe tip.

You can also order 3300 XL 8 mm probes and extension cables with an optional FluidLoc cable option. This option prevents oil and other liquids from leaking out of the machine through the cable's interior.

## Connectors

The 3300 XL probe, extension cable, and Proximito sensor have corrosion-resistant, gold-plated ClickLoc connectors. These connectors require only finger-tight torque (the

connectors will "click" when tight), and the specially-engineered locking mechanism prevents the connectors from loosening. These connectors require no special tools for installation or removal.

You can order the 3300 XL 8 mm probes and extension cables with connector protectors already installed. We can also supply connector protectors separately for field installations (such as when an application must run the cable through restrictive conduit). We recommend connector protectors for all installations to provide increased environmental protection<sup>8</sup>.

## Extended Temperature Range Applications

An extended temperature range (ETR) probe and ETR extension cable are available for applications in which either the probe lead or extension cable may exceed the standard 177°C (350°F) temperature specification. The ETR probe has an extended temperature rating for up to 218°C (425°F). The ETR extension cable rating is up to 260°C (500°F). Both the ETR probe and cable are compatible with standard temperature probes and cables, for example, you can utilize an ETR probe with the 330130 extension cable. The ETR system uses the standard 3300 XL Proximito Sensor. Note that when you use any ETR component as part of your system, the ETR component limits the system accuracy to the accuracy of the ETR system.

## Description Notes:

1. One-meter systems do not use an extension cable.
2. Proximito sensors are supplied by default from the factory calibrated to AISI 4140 steel. Calibration to other target materials is available upon request.
3. Consult Bently Nevada Applications Note, Considerations when using Eddy Current Proximity Probes for Overspeed Protection Applications, when considering this transducer system for tachometer or overspeed measurements.

4. 3300 XL 8 mm components are both electrically and physically interchangeable with non-XL 3300 5 mm and 8 mm components. Although the packaging of the 3300 XL Proximity Sensor differs from its predecessor, its design fits in the same 4-hole mounting pattern when used with the 4-hole mounting base, and will fit within the same mounting space specifications (when minimum permissible cable bend radius is observed).

5. Mixing XL and non-XL 3300-series 5 mm and 8 mm system components limits system performance to the specifications for the non-XL 3300 5 mm and 8 mm Transducer System.

6. The 3300-series 5 mm probe (refer to Document 141605) uses smaller physical packaging, but does not reduce the side view clearances or tip-to-tip spacing requirements as compared to an 8mm probe. It is used when physical (not electrical) constraints preclude the use of an 8 mm probe. When your application requires narrow side view probes, use the 3300 NSv Proximity Transducer System (refer to Document 147385).

7. 8 mm probes provide a thicker encapsulation of the probe coil in the molded PPS plastic probe tip. This results in a more rugged probe. The larger diameter of the probe body also provides a stronger, more robust case. We recommend that you use 8 mm probes when possible to provide optimal robustness against physical abuse.

8. Each 3300 XL extension cable includes silicone tape that you can use instead of connector protectors. We do not recommend silicone tape for applications that will expose the probe-to-extension cable connection to turbine oil.

## Specifications

Unless otherwise noted, the following specifications are for a 3300 XL 8 mm Proximity Sensor, extension cable and 8 mm probe between +18°C and +27°C (+64°F to +80°F) at a maximum altitude of 2000 meters, with a -24 Vdc power supply, a 10 k $\Omega$  load, an AISI 4140 steel target, and a probe gapped at 1.27 mm (50 mils). Performance characteristics apply to systems that consist solely of 3300 XL 8 mm components. The system accuracy and interchangeability specifications do not apply to transducer systems that are calibrated to any target other than our AISI 4140 steel target.

### Electrical

Proximity Sensor Input	Accepts one non-contacting 3300-series 5 mm, 3300 XL 8 mm Proximity Probe and Extension Cable.
Power	Requires -17.5 Vdc to -26 Vdc when installed with non-incandive circuit connected per installation drawing 140979 at 12 mA maximum consumption, -23 Vdc to -26 Vdc with barriers. Operation at a more positive voltage than -23.5 Vdc can result in reduced linear range.
Supply Sensitivity	Less than 2 mV change in output voltage per volt change in input voltage.
Output Resistance	50 $\Omega$

Nominal Probe DC Resistance	
Resistance ( $R_{\text{PROBE}}$ ) from Center Conductor to Outer Conductor	
Probe Length (m)	$R_{\text{PROBE}}$ ( $\Omega$ )
0.5	7.45 $\pm$ 0.50
1.0	7.59 $\pm$ 0.50
1.5	7.73 $\pm$ 0.50
2.0	7.88 $\pm$ 0.50
3.0	8.17 $\pm$ 0.50
5.0	8.73 $\pm$ 0.50
9.0	9.87 $\pm$ 0.50

Nominal Extension Cable DC Resistance	
Resistance ( $R_{\text{CORE}}$ ) from Center Conductor to Center Conductor	
Length of Extension Cable (m)	$R_{\text{CORE}}$ ( $\Omega$ )
3.0	0.66 $\pm$ 0.10
3.5	0.77 $\pm$ 0.12
4.0	0.88 $\pm$ 0.13
4.5	0.99 $\pm$ 0.15
6.0	1.32 $\pm$ 0.21
7.0	1.54 $\pm$ 0.23
7.5	1.65 $\pm$ 0.25
8.0	1.76 $\pm$ 0.26
8.5	1.87 $\pm$ 0.28

<b>Resistance (<math>R_{\text{JACKET}}</math>) from Outer Conductor to Outer Conductor</b>	
<b>Length of Extension Cable (m)</b>	<b><math>R_{\text{JACKET}}</math> (<math>\Omega</math>)</b>
3.0	0.20 ± 0.04
3.5	0.23 ± 0.05
4.0	0.26 ± 0.05
4.5	0.30 ± 0.06
6.0	0.39 ± 0.08
7.0	0.46 ± 0.09
7.5	0.49 ± 0.10
8.0	0.53 ± 0.11
8.5	0.56 ± 0.11

Extension Cable Capacitance	69.9 pF/m (21.3 pF/ft) typical
Field Wiring	0.2 to 1.5 mm <sup>2</sup> (16 to 24 AWG). Recommend using 3 conductor shielded triad cable and tinned field wiring. Maximum length of 305 meters (1,000 feet) between the 3300 XL Proximitor Sensor and the monitor. See the frequency response graphs, Figures 10 and 12, for signal rolloff at high frequencies when using longer field wiring lengths.
Linear Range	2 mm (80 mils). Linear range begins at approximately 0.25 mm (10 mils) from target and is from 0.25 to 2.3 mm (10 to 90 mils) (approximately -1 to -17 Vdc).

Recommended Gap Setting for Radial Vibration	-9 Vdc [approximately 1.27 mm (50 mils)]
--	--

<b>Incremental Scale Factor (ISF)</b>	
Standard 5 or 1 meter System	7.87 V/mm (200 mV/mil) ± 5% including interchangeability error when measured in increments of 0.25 mm (10 mils) over the 80 mil linear range from 0°C to +45°C (+32°F to +113°F).
Standard 9 meter System	7.87 V/mm (200 mV/mil) ± 6.5% including interchangeability error when measured in increments of 0.25 mm (10 mils) over the 80 mil linear range from 0°C to +45°C (+32°F to +113°F).
Extended Temperature Range (ETR) for 5 and 9 Meter Systems	7.87 V/mm (200 mV/mil) ± 6.5% including interchangeability error when measured in increments of 0.25 mm (10 mils) over the 80 mil linear range from 0°C to +45°C (+32°F to +113°F).

<b>Deviation from best fit straight line (DSL)</b>	
Standard 5 or 1 meter System	Less than ±0.025 mm (±1 mil) with components at 0°C to +45°C (+32°F to +113°F).
Standard 9 meter System	Less than ±0.038 mm (±1.5 mil) with components at 0°C to +45°C (+32°F to +113°F).
Extended Temperature Range 5 and 9 meter Systems	Less than ±0.038 mm (±1.5 mil) with components at 0°C to +45°C (+32°F to +113°F).

**Performance over Extended Temperatures**

Standard 5 or 1 meter System	<p>Over a probe temperature range of <math>-35^{\circ}\text{C}</math> to <math>+120^{\circ}\text{C}</math> (<math>-31^{\circ}\text{F}</math> to <math>+248^{\circ}\text{F}</math>) with the Proximitor sensor and extension cable between <math>0^{\circ}\text{C}</math> to <math>+45^{\circ}\text{C}</math> (<math>+32^{\circ}\text{F}</math> to <math>+113^{\circ}\text{F}</math>), the ISF remains within <math>\pm 10\%</math> of <math>7.87\text{ V/mm}</math> (<math>200\text{ mV/mil}</math>) and the DSL remains within <math>\pm 0.076\text{ mm}</math> (<math>\pm 3\text{ mils}</math>).</p> <p>Over a Proximitor sensor and extension cable temperature range of <math>-35^{\circ}\text{C}</math> to <math>+65^{\circ}\text{C}</math> (<math>-31^{\circ}\text{F}</math> to <math>+149^{\circ}\text{F}</math>) with the probe between <math>0^{\circ}\text{C}</math> to <math>+45^{\circ}\text{C}</math> (<math>+32^{\circ}\text{F}</math> to <math>+113^{\circ}\text{F}</math>), the ISF remains within <math>\pm 10\%</math> of <math>7.87\text{ V/mm}</math> (<math>200\text{ mV/mil}</math>) and the DSL remains within <math>\pm 0.076\text{ mm}</math> (<math>\pm 3\text{ mils}</math>).</p>
Standard 9 meter System	<p>Over a probe temperature range of <math>-35^{\circ}\text{C}</math> to <math>+120^{\circ}\text{C}</math> (<math>-31^{\circ}\text{F}</math> to <math>+248^{\circ}\text{F}</math>) with the Proximitor sensor and extension cable between <math>0^{\circ}\text{C}</math> to <math>+45^{\circ}\text{C}</math> (<math>+32^{\circ}\text{F}</math> to <math>+113^{\circ}\text{F}</math>), the ISF remains within <math>\pm 18\%</math> of <math>7.87\text{ V/mm}</math> (<math>200\text{ mV/mil}</math>) and the DSL remains within <math>\pm 0.152\text{ mm}</math> (<math>\pm 6\text{ mils}</math>).</p> <p>Over a Proximitor sensor and extension cable temperature range of <math>-35^{\circ}\text{C}</math> to <math>+65^{\circ}\text{C}</math> (<math>-31^{\circ}\text{F}</math> to <math>+149^{\circ}\text{F}</math>) with the probe between <math>0^{\circ}\text{C}</math> to <math>+45^{\circ}\text{C}</math> (<math>+32^{\circ}\text{F}</math> to <math>+113^{\circ}\text{F}</math>), the ISF remains within <math>\pm 18\%</math> of <math>7.87\text{ V/mm}</math> (<math>200\text{ mV/mil}</math>) and the DSL remains within <math>\pm 0.152\text{ mm}</math> (<math>\pm 6\text{ mils}</math>).</p>

Extended Temperature Range 5 and 9 meter Systems	Over a probe and extension cable temperature range of $-35^{\circ}\text{C}$ to $+260^{\circ}\text{C}$ ( $-31^{\circ}\text{F}$ to $+500^{\circ}\text{F}$ ) with the Proximitor sensor between $0^{\circ}\text{C}$ to $+45^{\circ}\text{C}$ ( $+32^{\circ}\text{F}$ to $+113^{\circ}\text{F}$ ), the ISF remains within $\pm 18\%$ of $7.87\text{ V/mm}$ ( $200\text{ mV/mil}$ ) and the DSL remains within $\pm 0.152\text{ mm}$ ( $\pm 6\text{ mils}$ ).
Frequency Response	(0 to 10 kHz), +0, -3 dB, with up to 305 meters (1000 feet) of field wiring.
Minimum Target Size	15.2 mm (0.6 in) diameter (flat target)
Shaft Diameter	
Minimum	50.8 mm (2 in)
Recommended Minimum	76.2 mm (3 in)

 When gapped at the center of the linear range, the interaction between two separate transducer systems (cross-talk) will be less than 50 mV on shaft diameters of at least 50 mm (2 in) or greater. You should take care to maintain minimum separation of transducer tips, generally at least 40 mm (1.6 in) for axial position measurements or 38 mm (1.5 in) for radial vibration measurements to limit cross-talk to 50 mV or less. Radial vibration or position measurements on shaft diameters smaller than 76.2 mm (3 in) will generally change the scale factor.

Effects of 60 Hz Magnetic Fields Up to 300 Gauss				
Output Voltage in Mil pp/Gauss				
Gap	5 or 1-meter Proximity Sensor	9 meter Proximity Sensor	Probe	Ext. Cable
10	0.0119	0.0247	0.0004	0.0004
50	0.0131	0.0323	0.0014	0.0014
90	0.0133	0.0348	0.0045	0.0045

### Mechanical

Probe Tip Material	Polyphenylene sulfide (PPS).
Probe Case Material	AISI 303 or 304 stainless steel (SST).

Probe Cable Specifications	
Standard cable	75Ω triaxial, fluoroethylene propylene (FEP) insulated probe cable in the following total probe lengths: 0.5, 1, 1.5, 2, 3, 5, or 9 meters.
Extended Temperature Range cable	75Ω triaxial, perfluoroalkoxy (PFA) insulated probe cable in the following total probe lengths: 0.5, 1, 1.5, 2, 5, or 9 meters.
Armor (optional on both)	Flexible AISI 302 or 304 SST with FEP outer jacket.
Tensile Strength (Maximum Rated)	330 N (75 lbf) probe case to probe lead. 270 N (60 lbf) at probe lead to extension cable connectors.

Connector Material	Gold-plated brass or gold-plated beryllium copper.
--------------------	--

Probe Case Torque		
Probe Type	Maximum Rated	Recommended
Standard forward mounted probes	33.9 N•m (300 in•lbf)	11.2 N•m (100 in•lbf)
Standard forward-mount probes - first three threads	22.6 N•m (200 in•lbf)	7.5 N•m (66 in•lbf)
Reverse-mount probes	22.6 N•m (200 in•lbf)	7.5 N•m (66 in•lbf)

Extension Cable Material	
Standard cable	75 Q triaxial, fluoroethylene propylene (FEP) insulated
Extended Temperature Range cable	75Ω triaxial, perfluoroalkoxy (PFA) insulated.
Minimum Cable Bend Radius	25.4 mm (1.0 in)

 3300 XL 8 mm components are both electrically and physically interchangeable with non-XL 3300 5 mm and 8 mm components when minimum permissible cable bend radius is observed.

Connector Material	Gold-plated brass or gold-plated beryllium copper.
Maximum Connector Torque	0.565 N•m (5 in•lbf)

**Connector-to-Connector Recommended Torque**

Connector Type	Tightening Instructions
Two 3300 XL gold "click" type connectors	Finger tight
One non-XL stainless steel connector and one 3300 XL connector	Finger tight plus 1/8 turn using pliers

**Materials**

Proximator Sensor Material	A308 aluminum
Connector Material	Gold-plated brass or gold-plated beryllium copper.

**Length**

System Length	5 or 9 meters (including extension cable) or 1 meter (probe only).
---------------	--

**Weight**

Total System Weight (Typical)	0.7 kg (1.5 lb m)
Probe	323 g/m (11.4 oz)
Extension Cable	34 g/m (0.4 oz/ft)
Armored Extension Cable	103 g/m (1.5 oz/ft)
Proximator Sensor	246 g (8.67 oz)

**Thread Engagement Limits**

Probe Case Thread	Maximum Length of Thread Engagement
<b>3/8-24</b>	0.563 in
<b>M10x1</b>	15 mm



Maximum thread engagement lengths are per the industry standard of 1.5 times the nominal thread diameter. A fit class matching that of the external probe thread is assumed for all internal threads. Applications with thread engagement lengths exceeding the values in the table above may exhibit binding during installation. Contact your Bently Nevada representative if you require probe thread engagement lengths exceeding the values above. Bently Nevada does not replace proximity probes under warranty due to excessive thread engagement lengths.

## Environmental Limits

### Probe Temperature Range

#### Operating and Storage Temperature

Standard Probe	-52°C to +177°C (-62°F to +350°F)
Extended Temperature Range Probe	-52°C to +218°C (-62°F to +425°F) for the probe tip; -51°C to +260°C (-60°F to +500°F) for the probe cable and connector.



Exposing the probe to temperatures below -34°C (-30°F) may cause premature failure of the pressure seal.

### Probe Pressure

3300 XL 8 mm probes are designed to seal differential pressure between the probe tip and case. The probe sealing material consists of a Viton® O ring. Probes are not pressure tested prior to shipment. Contact our custom design department if you require a test of the pressure seal for your application.



It is the responsibility of the customer or user to ensure that all liquids and gases are contained and safely controlled should leakage occur from a proximity probe. In addition, solutions with high or low pH values may erode the tip assembly of the probe causing media leakage into surrounding areas. Bently Nevada does not be held responsible for any damages resulting from leaking 3300 XL 8 mm proximity probes. In addition, 3300 XL 8 mm proximity probes does not be replaced under the service plan due to probe leakage.

### Extension Cable Temperature Range

#### Operating and Storage Temperature

Standard Cable	-52°C to +177°C (-62°F to +350°F)
Extended Temperature Range Cable	-52°C to +260°C (-62°F to +500°F)

### Proximitors Sensor Temperature Range

Operating Temperature	-52°C to +100°C (-62°F to +212°F)
Storage Temperature	-52°C to +105°C (-62°F to +221°F)

### Probe Relative Humidity

Less than a 3% change in Average Scale Factor (ASF) when tested in 93% humidity in accordance with IEC standard 68 2 3 for up to 56 days.

## Compliance and Certifications

### FCC

This device complies with part 15 of the FCC Rules. Operation is subject to the following two conditions:

- This device may not cause harmful interference.
- This device must accept any interference received, including interference that may cause undesired operation.

### EMC

European Community Directive:

EMC Directive 2014/30/EU

Standards

EN 61000-6-2; Immunity for Industrial Environments

EN 61000-6-4; Emissions for Industrial Environments

### RoHS

European Community Directive:

RoHS Directive 2011/65/EU

### China RoHS

Cables associated with the product(s) mentioned in this datasheet have an EFUP designation of 15 years, in accordance with SJ/T 11364-2024.



### Maritime

2019 Rules for Conditions of Classification,  
Part 1, 1-1-1/7.7, 1-1-A3, 1-1-A4

2019 Rules for Conditions of Classification,  
Part 1, Offshore Units and Structures  
1-1-4/9.7, 1-1-A2, 1-1-A3

## Functional Safety

SIL 2, HFT = 0

SIL 3, HFT = 1

## Hazardous Area Approvals



For the detailed listing of country and product-specific approvals, refer to the [Approvals Quick Reference Guide \(108M1756\)](#).

For additional technical documentation, please log in to [bntechsupport.com](http://bntechsupport.com) and access the Bently Nevada Media Library.

## CNRTLus

### 3300 XL Proximator Sensor

<p><b>ia</b></p> <p>When installed with intrinsically safe zener barriers per drawing 141092 or when installed with galvanic isolators.</p>	<p>Class I, Zone 0: AEx/Ex ia IIC T4/T5 Gc; Class I, Groups A, B, C, and D, Class II, Groups E, F and G, Class III;</p> <p>T5 @ Ta = -55°C to + 40°C.          T4 @ Ta = -55°C to + 80°C.</p>
<p><b>nA, ec</b></p> <p>When installed with non-incendive circuit connected per drawing 140979.</p>	<p>Class I, Zone 2: AEx/Ex nA IIC T4/T5 Gc; Class I, Division 2, Groups A, B, C, and D;          Class I, Zone 2: AEx/Ex ec IIC T4/T5 Gc; Class I, Division 2, Groups A, B, C, and D;</p> <p>T5 @ Ta = -55°C to + 40°C          T4 @ Ta = -55°C to + 80°C</p>

### 3300 XL Probe

<p><b>ia</b></p> <p>When installed with intrinsically safe zener barriers per drawing 141092 or when installed with galvanic isolators.</p>	<p>Class I, Zone 0: AEx/Ex ia IIC T5...T1 Gc; Class I, Groups A, B, C, and D, Class II, Groups E, F, and G, Class III;</p> <p>(see Temperature Schedule table to follow)</p>
---	--

<p><b>nA, ec</b></p> <p>When installed with non-incendive circuit connected per drawing 140979.</p>	<p>Class I, Zone 2: AEx/Ex nA IIC T5...T1 Gc; Class I, Division 2, Groups A, B, C, D; Class I, Zone 2: AEx/Ex ec IIC T5...T1 Gc; Class I, Division 2, Groups A, B, C, and D;</p> <p>(see Temperature Schedule table to follow)</p>
---	--

## ATEX/IECEx



### 3300 XL Proximator Sensor

<p><b>ia</b></p>	<p style="text-align: center;"></p> <p>II 1 G          Ex ia IIC T4/T5 Gc          Ex ia III C T90C/T105C Dc          For EPL Dc:          T105C @ Ta = -55°C to 100°C          T90C @ Ta = -55°C to +85°C</p> <table border="1" data-bbox="1098 909 1452 1155"> <tr> <td>Ui = -28V</td> <td>Uo = -28V</td> </tr> <tr> <td>Ii = 140mA</td> <td>Io = 140mA</td> </tr> <tr> <td>Pi = 0.91W</td> <td>Po = 0.742W</td> </tr> <tr> <td>Ci = 47nF</td> <td>Co = 1.5nF</td> </tr> <tr> <td>Li = 1460µH</td> <td>Lo = 610µH</td> </tr> </table>	Ui = -28V	Uo = -28V	Ii = 140mA	Io = 140mA	Pi = 0.91W	Po = 0.742W	Ci = 47nF	Co = 1.5nF	Li = 1460µH	Lo = 610µH
Ui = -28V	Uo = -28V										
Ii = 140mA	Io = 140mA										
Pi = 0.91W	Po = 0.742W										
Ci = 47nF	Co = 1.5nF										
Li = 1460µH	Lo = 610µH										
<p><b>nA,ec</b></p>	<p style="text-align: center;"></p> <p>II 3 G          Ex nA IIC T4/T5 Gc          Ex ec IIC T4/T5 Gc</p> <table border="1" data-bbox="1098 1312 1452 1361"> <tr> <td>Ui = -28V</td> <td>Ii = 140 mA</td> </tr> </table> <p>T5 @ Ta = -55°C to + 40°C          T4 @ Ta = -55°C to + 80°C</p>	Ui = -28V	Ii = 140 mA								
Ui = -28V	Ii = 140 mA										

### 3300 XL Probe



Probe entity parameters are met when used with BN extension cables and connected to BN Prox.

<p><b>ia</b></p>	<p style="text-align: center;"></p> <p><b>II 1 G</b>          Ex ia IIC T5...T1 Ga,          (see Temperature Schedule table to follow)</p> <p>Ex ia III C T90°C ... T280°C Dc          For EPL Dc:</p> <table border="1" data-bbox="379 517 730 663"> <tr> <td>Ui = -28V</td> <td>Ci = 1.5 nF</td> </tr> <tr> <td>Ii = 140 mA</td> <td>Li = 610 μH</td> </tr> <tr> <td>Pi = 0.91 W</td> <td></td> </tr> </table>	Ui = -28V	Ci = 1.5 nF	Ii = 140 mA	Li = 610 μH	Pi = 0.91 W	
Ui = -28V	Ci = 1.5 nF						
Ii = 140 mA	Li = 610 μH						
Pi = 0.91 W							
<p><b>nA,ec</b></p>	<p style="text-align: center;"></p> <p><b>II 3 G</b>          Ex nA IIC T5...T1 Gc,          Ex ec IIC T5...T1 Gc,          (see Temperature Schedule table to follow)</p> <table border="1" data-bbox="379 875 730 920"> <tr> <td>Ui = -28V</td> <td>Ii = 140 mA</td> </tr> </table>	Ui = -28V	Ii = 140 mA				
Ui = -28V	Ii = 140 mA						

## Hazardous Area Conditions of Safe Use

### cNRTLus:

**ia**

Install per Bently Nevada drawing 141092.

**nA, ec**

Install per Bently Nevada drawing 140979.

### ATEX/IECEx:

**ia**

Install per Bently Nevada drawing 141092.

**nA, ec**

The Proximitors must be installed so as to provide the terminals with a degree of protection of at least IP54.

## Temperature Schedule

Temperature Classification	Ambient Temperature (Probe Only)
For EPL Ga and Gc	
T1	-55°C to +232°C
T2	-55°C to +177°C
T3	-55°C to +120°C
T4	-55°C to +80°C
T5	-55°C to +40°C
For EPL Dc	
T280°C @ Ta	-55°C to +232°C
T225°C @ Ta	-55°C to +177°C
T170°C @ Ta	-55°C to +120°C
T130°C @ Ta	-55°C to +80°C
T105°C @ Ta	-55°C to +100°C
T90°C @ Ta	-55°C to +40°C

## Ordering Information



For the detailed listing of country and product-specific approvals, refer to the [Approvals Quick Reference Guide \(108M1756\)](#).

For additional technical documentation, please log in to [bntechsupport.com](http://bntechsupport.com) and access the Bently Nevada Media Library.

## Ordering Information for Probes

### 3300 XL 8 mm Proximity Probes:

**330101** 3300 XL 8 mm Probe, 3/8-24 UNF thread, without armor(2)

**330102** 3300 XL 8 mm Probe, 3/8-24 UNF thread, with armor(2)

#### Part Number-AA-BB-CC-DD-EE

#### A: Unthreaded Length Option



Unthreaded length must be at least 0.8 in. less than the case length.

Order in increments of 0.1 in.

#### Length configurations:

Maximum unthreaded length: 8.8 in.

Minimum unthreaded length: 0.0 in.

Example: **0 4** = 0.4 in.

#### B: Overall Case Length Option

Order in increments of 0.1 in.

#### Standard thread configurations:

Maximum case length: 9.6 in.

Minimum case length: 0.8 in.

Example: **2 4** = 2.4 in.

#### C: Total Length Option

<b>05</b>	0.5 meter (1.6 feet)
<b>10</b>	1.0 meter (3.3 feet)
<b>15</b>	1.5 meter (4.9 feet)

<b>20</b>	2.0 meters (6.6 feet)
<b>30</b>	3.0 meters (9.8 feet)
<b>50</b>	5.0 meters (16.4 feet)
<b>90</b>	9.0 meters (29.5 feet)



3-meter length option is only available on 330101 probes, and is designed for use with the 9 meter Proximitor sensor only.



5-meter probes are designed for use with the 5 meter Proximitor sensor only.

#### D: Connector and Cable-Type Option

<b>01</b>	Miniature coaxial ClickLoc connector with connector protector, standard cable
<b>02</b>	Miniature coaxial ClickLoc connector, standard cable
<b>11</b>	Miniature coaxial ClickLoc connector with connector protector, FluidLoc cable
<b>12</b>	Miniature coaxial ClickLoc connector, FluidLoc cable

#### E: Agency Approval Option

<b>00</b>	Not required
<b>05</b>	CSA, ATEX, IECEx Approvals

### 3300 XL 8 mm Proximity Probes, Metric:

**330103** 3300 XL 8 mm Probe, M10 x 1 thread, without armor (2)

**330104** 3300 XL 8 mm Probe, M10 x 1 thread, with armor (2)

#### Part Number-AA-BB-CC-DD-EE

#### A: Unthreaded Length Option

**A: Overall Case Length Option**

Order in increments of 0.5 in.

**Length configurations:**

Maximum unthreaded length: 9.5 in.

Minimum unthreaded length: 1.0 in.

Example: **3 5** = 3.5 in.

**B: Total Length Option**

<b>05</b>	0.5 meter (1.6 feet)
<b>10</b>	1.0 meter (3.3 feet)
<b>15</b>	1.5 meter (4.9 feet)
<b>20</b>	2.0 meters (6.6 feet)
<b>50</b>	5.0 meters (16.4 feet)
<b>90</b>	9.0 meters (29.5 feet)



5-meter probes are designed for use with the 5 meter Proximitor sensor only.

**C: Agency Approval Option**

<b>00</b>	Not required
<b>05</b>	CSA, ATEX, IECEx Approvals

**Aluminum probe clamp bracket**

**137491-AA**

**A: Mounting screw option**

<b>01</b>	10-24 UNC-2A mounting screws
<b>02</b>	M5 x 0.8-6g mounting screws

The aluminum clamp bracket is an unthreaded mounting bracket designed for use with the smooth case probes (330140, 330141, 330197 and 330198). After gapping the probe, tighten the clamp bracket by tightening the screws. The mounting screws have pre-drilled holes for safety wire.

**Aluminum probe threaded mounting bracket**

**137492-AA**

**A: Thread size**

<b>01</b>	3/8-24
<b>04</b>	M10 x 1

The aluminum probe threaded mounting bracket is the standard mounting bracket for most 3300 and 3300 XL probe installations. The -01 option includes two 10-24 UNC-2A mounting screws. The -04 option includes two M5 x 0.8-6g mounting screws. The mounting screws have pre-drilled holes for safety wire.

**Phenolic threaded probe mounting bracket**

**27474-AA**

**A: Thread size**

<b>01</b>	3/8-24
<b>04</b>	M10 x 1

Bently Nevada recommends the phenolic threaded mounting bracket if your application requires additional electric isolation from the mounting location (as in some generator and electrical motor bearing locations). The -01 option includes two 10-24 UNC-2A mounting screws. The -04 option includes two M5 x 0.8-6g mounting screws. The mounting screws have pre-drilled holes for safety wire.

**Probe Ordering Information Notes:**

1. Mounting clamps must be ordered separately for 330140, 330141, 330197, and 330198.
2. For a shorter delivery time, order commonly stocked probes. The following part numbers are currently stocked probes:

330101-00-08-05-02-00, 330101-00-08-05-02-05, 330101-00-08-10-02-00, 330101-00-08-10-02-05, 330101-00-12-10-02-00, 330101-00-12-10-02-05, 330101-00-16-10-02-00, 330101-00-16-10-02-05, 330101-00-20-05-02-00, 330101-00-20-10-02-00, 330101-00-20-10-02-05, 330101-00-30-10-02-00, 330101-00-30-10-02-05, 330101-00-40-05-02-00, 330101-00-40-10-02-00, 330101-00-40-10-02-05, 330101-00-60-10-02-00, 330101-00-60-10-02-05, 330102-00-20-10-02-00, 330103-00-02-10-02-05, 330103-00-04-10-02-00, 330103-00-05-10-02-00, 330104-00-06-10-02-00, 330104-01-05-50-02-00, 330105-02-12-05-02-00, 330105-02-12-05-02-05, 330105-02-12-10-02-00, 330105-02-12-10-02-05, 330106-05-30-05-02-00, 330106-05-30-05-02-05, 330106-05-30-10-02-00, 330106-05-30-10-02-05.

## Ordering Information for Proximitorsensor

### 3300 XL Proximitorsensor

#### 330180-AA-BB

##### A: Total Length and Mounting Option

<b>10</b>	1.0 meter (3.3 feet) system length, panel mount
<b>11</b>	1.0 meter (3.3 feet) system length, DIN mount
<b>12</b>	1.0 meter (3.3 feet) system length, no mounting hardware
<b>50</b>	5.0 meters (16.4 feet) system length, panel mount
<b>51</b>	5.0 meters (16.4 feet) system length, DIN mount
<b>52</b>	5.0 meters (16.4 feet) system length, no mounting hardware
<b>90</b>	9.0 meters (29.5 feet) system length, panel mount
<b>91</b>	9.0 meters (29.5 feet) system length, DIN mount

<b>92</b>	9.0 meters (29.5 feet) system length, no mounting hardware
<b>B: Agency Approval Option</b>	
<b>00</b>	Not required
<b>05</b>	CSA, ATEX, IECEx Approvals

## Ordering Information for Extension Cables

### 3300 XL Standard Extension Cable

#### 330130-AAA-BB-CC



Make sure that the extension cable length and the probe length, when added together, equal the Proximitorsensor total length.

##### A: Cable Length Option

<b>030</b>	3.0 meters (9.8 feet)
<b>035</b>	3.5 meters (13.1 feet)
<b>040</b>	4.0 meters (11.5 feet)
<b>045</b>	4.5 meters (14.8 feet)
<b>060</b>	6.0 meters (19.7 feet)
<b>070</b>	7.0 meters (22.9 feet)
<b>075</b>	7.5 meters (24.6 feet)
<b>080</b>	8.0 meters (26.2 feet)
<b>085</b>	8.5 meters (27.9 feet)

##### B: Connector Protector and Cable Option

<b>00</b>	Standard cable
<b>01</b>	Armored cable
<b>02</b>	Standard cable with connector protector

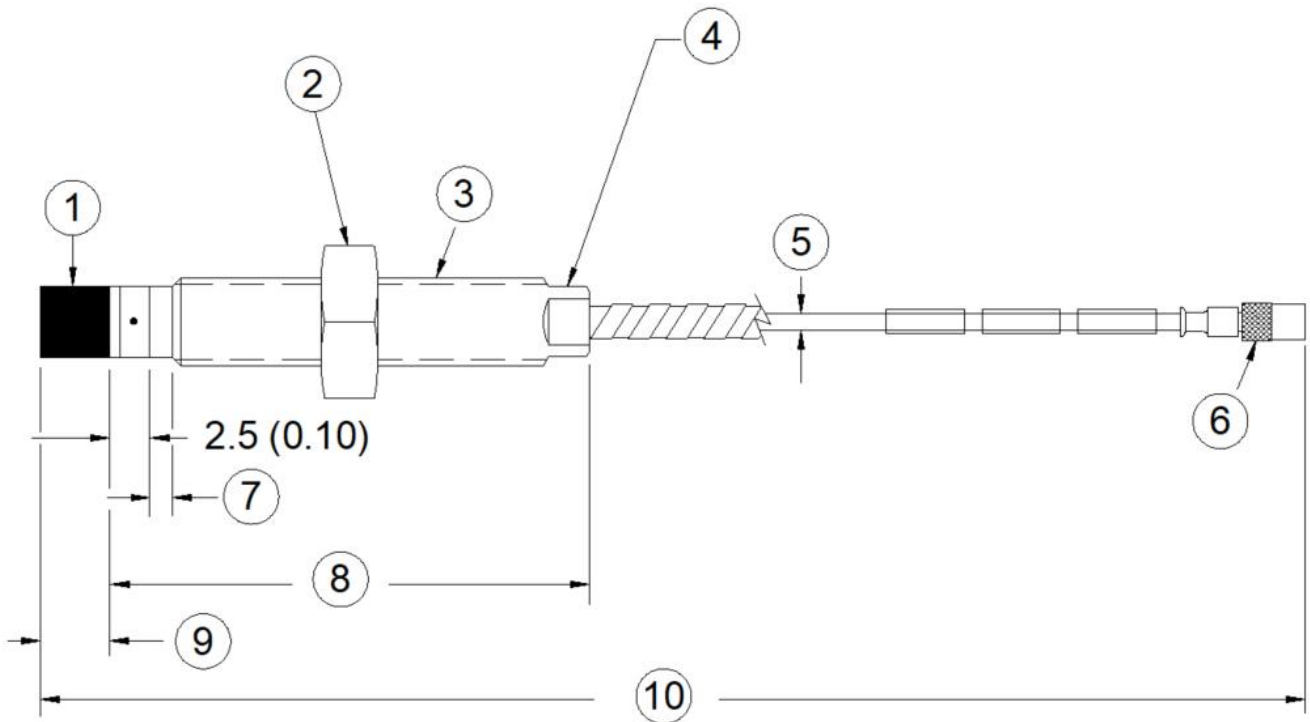

1. Probe tip, 8.0 mm (0.31 in) diameter
2. 9/16 in for 3/8-24 threads, M17 for M10 threads (see Note 2)
3. Case thread
4. 5/16 in wrench flats for 3/8-24 threads; 8mm wrench flats for M10 threads.
5. 75  $\Omega$  cable, 3.68 mm (0.145 in) maximum outside diameter, 3.94 mm (0.155 in) maximum outside diameter for FluidLoc cable, 7.67 mm (0.302 in) outside diameter of armor, 9.5 mm (0.38 in) maximum diameter of armor ferrule
6. Miniature male coaxial connector, 7.24 mm (0.285 in) maximum outside diameter "D"
7. Unthreaded length "A"
8. Case length "B"
9. 6.0 mm (0.235 in) maximum
10. Total length "C", +30%, -0%<sup>3</sup>

**Figure 14: 3300 XL 8 mm Proximity Probes, Standard Mount**

330101 and 330191, 3/8-24 UNF-2A, without armor 7

330102 and 330192, 3/8-24 UNF-2A, with armor 6

330103 and 330193, M10X1 thread, without armor 7

330104 and 330194, M10X1 thread, with armor 6