

E96-431

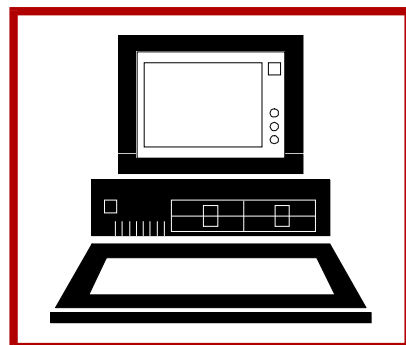

# Instruction

## Digital Output Termination Unit (NTDO02)

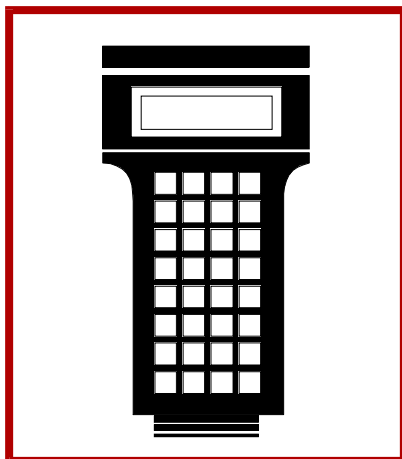
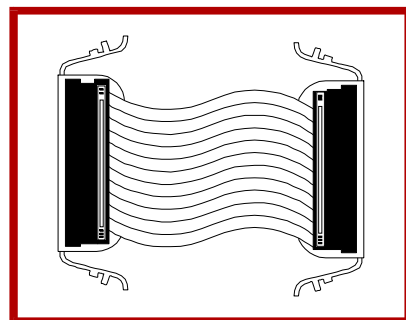
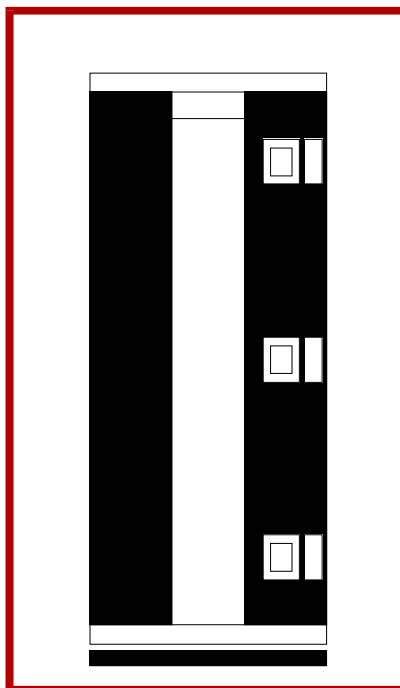
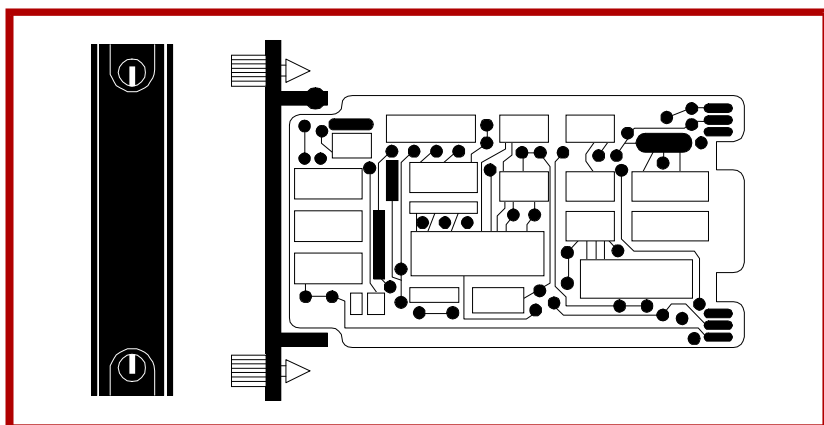
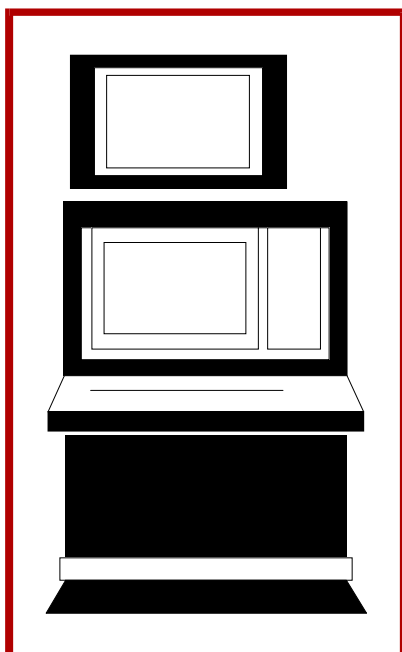

**WARNING** notices as used in this instruction apply to hazards or unsafe practices that could result in personal injury or death.

**CAUTION** notices apply to hazards or unsafe practices that could result in property damage.

**NOTES** highlight procedures and contain information that assists the operator in understanding the information contained in this instruction.

## WARNING

### INSTRUCTION MANUALS

DO NOT INSTALL, MAINTAIN, OR OPERATE THIS EQUIPMENT WITHOUT READING, UNDERSTANDING, AND FOLLOWING THE PROPER **Elsag Bailey** INSTRUCTIONS AND MANUALS; OTHERWISE, INJURY OR DAMAGE MAY RESULT.

### RADIO FREQUENCY INTERFERENCE

MOST ELECTRONIC EQUIPMENT IS INFLUENCED BY RADIO FREQUENCY INTERFERENCE (RFI). CAUTION SHOULD BE EXERCISED WITH REGARD TO THE USE OF PORTABLE COMMUNICATIONS EQUIPMENT IN THE AREA AROUND SUCH EQUIPMENT. PRUDENT PRACTICE DICTATES THAT SIGNS SHOULD BE POSTED IN THE VICINITY OF THE EQUIPMENT CAUTIONING AGAINST THE USE OF PORTABLE COMMUNICATIONS EQUIPMENT.

### POSSIBLE PROCESS UPSETS

MAINTENANCE MUST BE PERFORMED ONLY BY QUALIFIED PERSONNEL AND ONLY AFTER SECURING EQUIPMENT CONTROLLED BY THIS PRODUCT. ADJUSTING OR REMOVING THIS PRODUCT WHILE IT IS IN THE SYSTEM MAY UPSET THE PROCESS BEING CONTROLLED. SOME PROCESS UPSETS MAY CAUSE INJURY OR DAMAGE.

## AVERTISSEMENT

### MANUELS D'OPÉRATION

NE PAS METTRE EN PLACE, RÉPARER OU FAIRE FONCTIONNER L'ÉQUIPEMENT SANS AVOIR LU, COMPRIS ET SUIVI LES INSTRUCTIONS RÉGLEMENTAIRES DE **Elsag Bailey**. TOUTE NÉGLIGENCE À CET ÉGARD POURRAIT ÊTRE UNE CAUSE D'ACCIDENT OU DE DÉFAILLANCE DU MATÉRIEL.

### PERTURBATIONS PAR FRÉQUENCE RADIO

LA PLUPART DES ÉQUIPEMENTS ÉLECTRONIQUES SONT SENSIBLES AUX PERTURBATIONS PAR FRÉQUENCE RADIO. DES PRÉCAUTIONS DEVRONT ÊTRE PRISES LORS DE L'UTILISATION DU MATÉRIEL DE COMMUNICATION PORTATIF. LA PRUDENCE EXIGE QUE LES PRÉCAUTIONS À PRENDRE DANS CE CAS SOIENT SIGNALÉES AUX ENDROITS VOULUS DANS VOTRE USINE.

### PERTURBATIONS DU PROCÉDÉ

L'ENTRETIEN DOIT ÊTRE ASSURÉ PAR UNE PERSONNE QUALIFIÉE EN CONSIDÉRANT L'ASPECT SÉCURITAIRE DES ÉQUIPEMENTS CONTRÔLÉS PAR CE PRODUIT. L'AJUSTEMENT ET/OU L'EXTRACTION DE CE PRODUIT PEUT OCCASIONNER DES À-COUPS AU PROCÉDÉ CONTRÔLE LORSQU'IL EST INSÉRÉ DANS UNE SYSTÈME ACTIF. CES À-COUPS PEUVENT ÉGALEMENT OCCASIONNER DES BLESSURES OU DES DOMMAGES MATÉRIELS.

## NOTICE

The information contained in this document is subject to change without notice.

Elsag Bailey, its affiliates, employees, and agents, and the authors and contributors to this publication specifically disclaim all liabilities and warranties, express and implied (including warranties of merchantability and fitness for a particular purpose), for the accuracy, currency, completeness, and/or reliability of the information contained herein and/or for the fitness for any particular use and/or for the performance of any material and/or equipment selected in whole or part with the user of/ or in reliance upon information contained herein. Selection of materials and/or equipment is at the sole risk of the user of this publication.

This document contains proprietary information of Elsag Bailey, Elsag Bailey Process Automation, and is issued in strict confidence. Its use, or reproduction for use, for the reverse engineering, development or manufacture of hardware or software described herein is prohibited. No part of this document may be photocopied or reproduced without the prior written consent of Elsag Bailey.

---

## Preface

---

Termination units provide a signal path between plant equipment and the INFI 90® modules. The NTDO02 Digital Output Termination Unit connects the IMDSM05 Digital I/O Module or the IMDSO04 Digital Output Module with digital control devices such as annunciator panel lamps, motors and fans. The NTDO02 termination unit replaces the NTDO01 termination unit.

This instruction explains how to install and use the NTDO02 termination unit in the INFI 90 system. It contains sections that describe setup and cabling. The appendices provide a quick reference guide of dipswitch and jumper settings for modules that use the NTDO02 termination unit.

---

## List of Effective Pages

---

Total number of pages in this manual is 36, consisting of the following:

<b>Page No.</b>	<b>Change Date</b>
Preface	Original
List of Effective Pages	Original
iii through vi	Original
1-1 through 1-6	Original
2-1 through 2-11	Original
3-1 through 3-4	Original
4-1 through 4-3	Original
5-1	Original
A-1 through A-3	Original
B-1	Original
Index-1	Original

When an update is received, insert the latest changed pages and dispose of the superseded pages.

**NOTE:** On an updated page, the changed text or table is indicated by a vertical bar in the outer margin of the page at the changed area. A changed figure is indicated by a vertical bar in the outer margin next to the figure caption. The date the update was prepared will appear beside the page number.

---

## Safety Summary

---

### GENERAL WARNINGS

#### Equipment Environment

All components, whether in transportation, operation or storage, must be in a noncorrosive environment.

#### Electrical Shock Hazard During Maintenance

Disconnect power or take precautions to insure that contact with energized parts is avoided when servicing.

#### Special Handling

This module uses electrostatic sensitive devices.

### SPECIFIC WARNINGS

There are exposed electrical connections inside the cabinet. These exposed electrical connections present a shock hazard that can cause injury or death. (p. 3-1)

Never clean electrical parts or components with live power present. Doing so exposes you to an electrical shock hazard. (p. 3-1)

If input or output circuits are a shock hazard after disconnecting system power at the power entry panel, then the door of the cabinet containing these externally powered circuits must be marked with a warning stating that multiple power sources exist. (p. 3-1)

Wear eye protection whenever working with cleaning solvents. When removing solvents from printed circuit boards using compressed air, injury to the eyes could result from splashing solvent as it is removed from the printed circuit board. (p. 3-1)

### SPECIFIC CAUTIONS

Use only the CSA certified fuses and relays specified in this manual. Use the correct fuse for the selected relay. Failure to use the correct relay and fuse could cause damage to equipment. (p. 2-6, 4-1)

Remove a module from its assigned slot before installing or removing a cable assigned to that slot. Failure to do so could result in damage to the module. (p. 2-9, 4-2)

It is strongly recommended that all power (cabinet, I/O, etc.) be turned off before doing any wiring. Verify all connections before applying power. Failure to observe these precautions could result in equipment damage. (p. 2-9)

## Sommaire de Sécurité

**AVERTISSEMENTS  
D'ORDRE  
GÉNÉRAL****Environnement de l'équipement**

Ne pas soumettre les composants à une atmosphère corrosive lors du transport, de l'entreposage ou l'utilisation.

**Possibilité de chocs électriques durant l'entretien**

Débrancher l'alimentation ou prendre les précautions pour éviter tout contact avec des composants sous tension durant l'entretien.

**Precautions de manutention**

Ce module contient des composantes sensibles aux décharges électro-statiques.

**AVERTISSEMENTS  
D'ORDRE  
SPÉCIFIQUE**

L'intérieur de cette armoire contient des bornes électriques qui sont à découvert. Ces bornes électriques à découvert constituent un risque de choc qui pourrait causer blessure ou même la mort. (p. 3-1)

Ne jamais nettoyer des pièces ou composants électriques dont les circuits sont sous tension; les circuits alimentés pourraient causer un choc électrique. (p. 3-1)

Si des circuits d'entrée ou de sortie sont alimentés à partir de sources externes, ils présentent un risque de choc électrique même lorsque l'alimentation du système est débranchée du panneau d'entrée l'alimentation. Le cas échéant, un avertissement signalant la présence de sources d'alimentation multiples doit être apposé sur la porte de l'armoire. (p. 3-1)

Des lunettes de protection devraient être portées lors de travail avec des solvants nettoyants. Lorsqu'on enlève les solvants des circuits imprimés à l'aide d'air comprimé, les éclaboussures de solvant pourraient causer des blessures aux yeux. (p. 3-1)

**ATTENTIONS  
D'ORDRE  
SPÉCIFIQUE**

N'utiliser que des fusibles et des relais accrédités ACNOR tel que spécifié dans cette notice. Utiliser le fusible approprié pour le relais en cause. L'utilisation d'un relais ou fusible inapproprié pourrait causer des dommages à l'équipement. (p. 2-6, 4-1)

Avant de retirer ou de brancher un câble, retirez le module logé dans la coulisse correspondante. Autrement, le module risque d'être endommagé. (p. 2-9, 4-2)

Il est fortement recommandé de débrancher toute source d'alimentation (armoire, E/S, etc.) avant d'effectuer du travail au câblage. Vérifiez toutes les connexions avant de rétablir l'alimentation. Ces précautions permettent d'éviter des dommages à l'équipement. (p. 2-9)

---

# Table of Contents

	<i>Page</i>
<b>SECTION 1 - INTRODUCTION</b> .....	<b>1-1</b>
INTRODUCTION .....	1-1
INTENDED USER .....	1-1
HARDWARE DESCRIPTION .....	1-1
FEATURES .....	1-2
INSTRUCTION CONTENT .....	1-3
HOW TO USE THIS INSTRUCTION .....	1-3
REFERENCE DOCUMENTS .....	1-3
GLOSSARY OF TERMS AND ABBREVIATIONS .....	1-4
NOMENCLATURE .....	1-4
SPECIFICATIONS .....	1-4
<b>SECTION 2 - INSTALLATION</b> .....	<b>2-1</b>
INTRODUCTION .....	2-1
SPECIAL HANDLING .....	2-1
UNPACKING AND INSPECTION .....	2-2
SETUP/PHYSICAL INSTALLATION .....	2-2
Dipshunt Configuration .....	2-3
Normal Operation (XU01 and XU02) .....	2-3
Advanced Applications (XU01 and XU02) .....	2-4
I/O Module Selection (XU03 through XU10) .....	2-5
Fuse Installation .....	2-6
Relay Installation .....	2-7
INSTALLING THE TERMINATION UNIT .....	2-7
Mounting the Termination Unit .....	2-8
Termination Unit Cables .....	2-8
Power Wiring .....	2-9
Terminal Block Wiring .....	2-10
INSTALLATION COMPLETE .....	2-10
<b>SECTION 3 - MAINTENANCE</b> .....	<b>3-1</b>
INTRODUCTION .....	3-1
PREVENTIVE MAINTENANCE SCHEDULE .....	3-2
EQUIPMENT AND TOOLS REQUIRED .....	3-2
PREVENTIVE MAINTENANCE PROCEDURES .....	3-3
Printed Circuit Board Cleaning .....	3-3
General Cleaning and Washing .....	3-3
Checking Connections .....	3-4
<b>SECTION 4 - REPAIR/REPLACEMENT PROCEDURES</b> .....	<b>4-1</b>
INTRODUCTION .....	4-1
FUSE REPLACEMENT .....	4-1
RELAY REPLACEMENT .....	4-2
TERMINATION UNIT REPLACEMENT .....	4-2
<b>SECTION 5 - SUPPORT SERVICES</b> .....	<b>5-1</b>
INTRODUCTION .....	5-1
REPLACEMENT PARTS AND ORDERING INFORMATION .....	5-1
TRAINING .....	5-1
TECHNICAL DOCUMENTATION .....	5-1

## Table of Contents (continued)

	<i>Page</i>
<b>APPENDIX A - IMDSM05 DIGITAL I/O MODULE.....</b>	<b>A-1</b>
INTRODUCTION .....	A-1
<b>APPENDIX B - IMDSO04 DIGITAL OUTPUT MODULE.....</b>	<b>B-1</b>
INTRODUCTION .....	B-1

## List of Figures

<i>No.</i>	<i>Title</i>	<i>Page</i>
1-1.	Example TDO Termination Unit Application.....	1-2
2-1.	TDO Termination Unit Layout.....	2-2
2-2.	Dipshunt Socket XU01 and XU02 Internal Circuitry .....	2-4
2-3.	Example Configuration Using Dipshunts .....	2-4
2-4.	Example Configuration Using Adapter Plugs .....	2-5
2-5.	Mounting and Securing the Termination Unit .....	2-7
2-6.	Cable Connections.....	2-8
2-7.	Terminal Assignments .....	2-10
A-1.	IMDSM05 Digital I/O Module .....	A-1
B-1.	IMDSO04 Digital I/O Module.....	B-1

## List of Tables

<i>No.</i>	<i>Title</i>	<i>Page</i>
1-1.	Reference Documents .....	1-3
1-2.	Glossary of Terms and Abbreviations .....	1-4
1-3.	Nomenclature .....	1-4
1-4.	NTDO02 Termination Unit Specifications .....	1-5
1-5.	Relay and Fuse Specifications.....	1-5
2-1.	Dipshunt XU01 and XU02 Normal Operation Settings .....	2-3
2-2.	Dipshunt XU03 through XU10 Settings .....	2-6
2-3.	Fuse and Relay Ratings .....	2-6
2-4.	Cable Applications.....	2-8
3-1.	Preventive Maintenance Schedule .....	3-2
4-1.	Parts List.....	4-1
A-1.	IMDSM05 Dipswitch S1 Settings .....	A-2
A-2.	IMDSM05 Dipswitch S2 Settings .....	A-2
A-3.	IMDSM05 Dipswitch S3 Settings .....	A-2
A-4.	IMDSM05 Dipswitch S4 Settings .....	A-2
A-5.	IMDSM05 Dipswitch S5 Settings .....	A-3
A-6.	IMDSM05 Jumpers J1 through J16.....	A-3
A-7.	IMDSM05 Jumpers J17 and J18 .....	A-3
B-1.	IMDSM04 Dipswitch S4 Settings .....	B-1

---

## SECTION 1 - INTRODUCTION

---

### INTRODUCTION

The NTDO02 Digital Output Termination Unit can provide up to eight solid state relay outputs. The configuration contained in a control module determines the output state of the digital output termination unit (TDO) relays. The NTDO02 termination unit is a functional replacement for the NTDO01 termination unit.

The TDO termination unit interfaces with an I/O module through a cable connection. It can interface with an IMDSO04 Digital Output Module (DSO) or an IMDSM05 Digital I/O Module (DSM).

Each I/O module can have up to 16 output signals for relay control. Each of the 16 output signals can control up to nine relays via the NTDO02 termination unit. The DSM and DSO I/O modules can control up to 18 TDO termination units. If more than one termination unit is used, the additional termination units are interconnected. Figure 1-1 shows a typical TDO termination unit application.

---

### INTENDED USER

Anyone who installs, uses and maintains the TDO termination unit should read and understand this instruction before placing the termination unit into service. Installation and troubleshooting require a technician or engineer with electrical experience and an understanding of solid state relay operation.

---

### HARDWARE DESCRIPTION

The TDO termination unit is a seven-by-seven inch square printed circuit board. It mounts on the NFTP01 Field Termination Panel inside an INFI 90 cabinet. The board contains:

- Ten dipshunt sockets.
- Two terminal strips.
- Eight fuse holders (for relays).
- Eight relay sockets.
- Two cable sockets.
- 24 VDC faston connector.
- DC common faston connector.
- One fuse (24 VDC power).

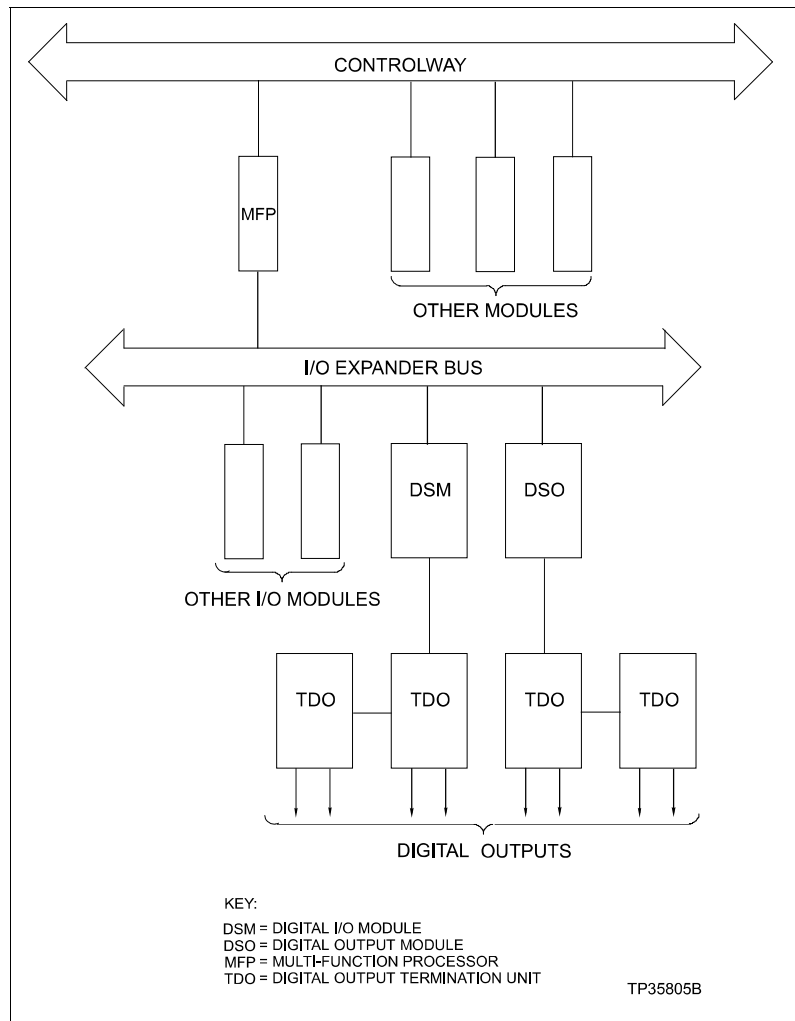

Figure 1-1. Example TDO Termination Unit Application

**FEATURES**

Using the NTDO02 termination unit, each I/O module output can be assigned to more than one solid state relay (nine maximum). One I/O module can operate up to 144 relays (16 output signals with nine relays each). This is done by interconnecting 18 NTDO02 termination units to accommodate 144 relays.

There are three types of relays available, each with different output capabilities. The relay type used depends on the current and voltage rating of the controlled device. Relays are not provided with the termination unit.

Each relay output is fused. The fuse (F1 through F8) value required for each relay depends on the current capability of the relay type used. Fuses F1 through F8 are not provided with the termination unit. Power (24 VDC) to switch the solid state relays is also fused (provided with termination unit).

---

**INSTRUCTION CONTENT**

This instruction has five sections and two appendices.

<b>Introduction</b>	Provides an overview of the TDO termination unit.
<b>Installation</b>	Explains the physical installation, wiring and cable requirements, dipshunt settings and handling of the termination unit.
<b>Maintenance</b>	Contains a maintenance schedule.
<b>Repair/Replacement Procedures</b>	Explains how to replace the fuses, relays and termination unit.
<b>Support Services</b>	Explains how to order parts and other services available from Bailey Controls Company.
<b>Appendices</b>	Briefly discuss the modules that use the termination unit and provide a cross reference of settings for those modules.

---

**HOW TO USE THIS INSTRUCTION**

Read this instruction through in sequence. Read **Section 2** thoroughly. Do the steps in order. Complete all steps in the **Section 2** before using the TDO termination unit. Refer to the Table of Contents or Index to find specific information after the unit is operating.

---

**REFERENCE DOCUMENTS**

Table 1-1 lists the documents referenced in this instruction.

*Table 1-1. Reference Documents*

<b>Document No.</b>	<b>Title</b>
I-E96-309	Digital I/O Module (IMDSM05)
I-E96-313	Digital Output Module (IMDSO04)
I-E96-500	Site Planning and Preparation

---

**GLOSSARY OF TERMS AND ABBREVIATIONS**

Table 1-2 lists definitions of terms and abbreviations used in this instruction.

*Table 1-2. Glossary of Terms and Abbreviations*

<b>Term</b>	<b>Definition</b>
Control Output	The control system signal that influences the operation of a final control element.
Dipshunt	Dual in-line package with shorting straps.
Dipswitch	Dual in-line package that contains switches.
I/O Module	One of a series of modules designed to perform low level operations as directed by a control module.
Termination Unit	Provides input/output connection between plant equipment and the INFI 90/Network 90® modules.

---

**NOMENCLATURE**

Table 1-3 is a list of related hardware.

*Table 1-3. Nomenclature*

<b>Nomenclature</b>	<b>Description</b>
IMDSM05	Digital I/O module
IMDSO04	Digital output module
NFTP01	Field termination panel
NKDO01	TDO cable to TDO cable (PVC)
NKDO11	TDO cable to TDO cable (non-PVC)
NKTU01	Termination unit cable (PVC)
NKTU11	Termination unit cable (non-PVC)

---

**SPECIFICATIONS**

Refer to Table 1-4 for termination unit specifications. Refer to Table 1-5 for relay and fuse specifications.

Table 1-4. NTDO02 Termination Unit Specifications

Property	Characteristic/Value
Power requirements	+24 VDC, 268 mA maximum current consumption
Cable insulation: PVC (UL rating PLTC) Non-PVC (UL rating PLTC)	80°C (176°F) at 300 V 90°C (194°F) at 300 V
Mounting	Screw mounts on the field termination panel
Environmental: Electromagnetic/radio frequency interference Cooling requirements Operating temperature Relative humidity Altitude Air quality	Values not available at this time. Keep cabinet doors closed. Do not use communication equipment any closer than 2 meters from cabinet. No cooling necessary when used in Bailey cabinets and operated within environmental limits 0° to 70°C (32° to 158°F) 5% to 90% up to 70°C (158°F) (noncondensing) Sea level to 3 km (1.86 miles) Bailey equipment should be operated and stored in a noncorrosive environment
Installation category	Category III
Certification	All termination units are CSA certified as process control equipment for use in an ordinary (nonhazardous) location.  Factory Mutual approved for Class I, Division 2, Groups A, B, C, D, hazardous (classified) locations.

SPECIFICATIONS ARE SUBJECT TO CHANGE WITHOUT NOTICE.

Table 1-5. Relay and Fuse Specifications

Property	Characteristic/Value
<b>Relay type</b>	<b>120 VAC (Bailey part no. 1947684_32)</b>
Fuse rating	4 A slo blo (60 A for one cycle surge)
Output (load) voltage range	12 VAC to 280 VAC
Output (load) current	3 A <sub>rms</sub> maximum from 15° to 25°C (59° to 77°F) 1.2 A <sub>rms</sub> maximum at 70°C (158°F)
Load frequency	47 to 63 Hz
Off-state leakage current	0.75 mA <sub>rms</sub> maximum
One cycle surge capability	85 A <sub>peak</sub> maximum
<b>Relay type</b>	<b>120 VAC (Bailey part no. 1947803_1)<sup>1</sup></b>
Fuse rating	4 A slo blo (60 A for one cycle surge)
Output (load) voltage range	24 VAC to 280 VAC
Output (load) current	3.5 A <sub>rms</sub> maximum from 0° to 30°C (32° to 86°F) 1.75 A <sub>rms</sub> maximum at 70°C (158°F)
Load frequency	47 to 63 Hz
Off-state leakage current	4 mA <sub>rms</sub> maximum
One cycle surge capability	80 A <sub>peak</sub> maximum

Table 1-5. Relay and Fuse Specifications (continued)

Property	Characteristic/Value
<b>Relay type</b> Fuse rating Output (load) voltage range Output (load) current Off-state leakage at 60 VDC One second surge capability	<b>24 VDC (Bailey part no. 1947685_31)</b> 3 A 5 VDC to 60 VDC 3 ADC maximum 15° to 25°C (59° to 77°F) 1.2 ADC maximum at 70°C (158°F) Inductive loads should be diode suppressed 10 µADC maximum 5 ADC maximum
<b>Relay type</b> Fuse rating Output (load) voltage range Output (load) current Off-state leakage at 200 VDC One second surge capability	<b>125 VDC (Bailey part no. 1947685_32)</b> 1 A 10 VDC to 200 VDC 1 ADC maximum 15° to 25°C (59° to 77°F) 400 mADC maximum at 70°C (158°F) Inductive loads should be diode suppressed 10 µADC maximum 1.5 ADC maximum
<b>Certification</b>	All relays are CSA approved. All DC relays pass IEEE-472-1989 test for surge and withstand capability.

**NOTE:**

1. Use this relay for AC applications requiring IEEE-472-1989 surge and withstand capability.

SPECIFICATIONS ARE SUBJECT TO CHANGE WITHOUT NOTICE.

---

## SECTION 2 - INSTALLATION

---

### INTRODUCTION

This section lists the steps to properly install the NTDO02 Digital Output Termination Unit (TDO). The installation procedure includes physical installation, dipshunt configuration, cable connection, power wiring and handling. To properly install the TDO termination unit do the steps in this section in the order they appear.

---

### SPECIAL HANDLING

Observe these steps when handling electronic circuitry:

**NOTE:** Always use Bailey's field static kit (part number 1948385\_1 - consisting of two wrist straps, ground cord assembly, alligator clip, and static dissipative work surface) when working with the modules. The kit grounds a technician and the static dissipative work surface to the same ground point to prevent damage to the modules by electrostatic discharge.

1. **Use Static Shielding Bag.** Keep the assemblies in the static shielding bag until you are ready to install them in the system. Save the bag for future use.
2. **Ground Bag Before Opening.** Before opening a bag containing an assembly with semiconductors, touch it to the equipment housing or a ground to equalize charges.
3. **Avoid Touching Circuitry.** Handle assemblies by the edges; avoid touching the circuitry.
4. **Avoid Partial Connection of Semiconductors.** Verify that all devices connected to the assemblies are properly grounded before using them.
5. **Ground Test Equipment.**
6. **Use an Antistatic Field Service Vacuum.** Remove dust from the assembly if necessary.
7. **Use a Grounded Wrist Strap.** Connect the wrist strap to the appropriate grounding plug on the power entry panel. The grounding plug on the power entry panel is connected to the earth grounding electrode system through the AC safety ground.
8. **Do Not Use Lead Pencils to Set Dipswitches.** To avoid contamination of dipswitch contacts that can result in unnecessary circuit board malfunction, do not use a lead pencil to set a dipswitch.

**UNPACKING AND INSPECTION**

1. Examine the hardware immediately for shipping damage.
2. Notify the nearest Bailey Controls Company sales office if any damage exists.
3. File a claim for any damage with the transportation company that handled the shipment.
4. Use the original packing material and container to store the hardware.
5. Store the hardware in an environment of good air quality, free from temperature and moisture extremes.

**SETUP/PHYSICAL INSTALLATION**

This section explains how to configure and install the TDO termination unit. Set the dipshunts, install the fuses and install the relays before placing the termination unit into operation. There are ten dipshunts, nine fuses and eight relays. Figure 2-1 shows the termination unit layout.

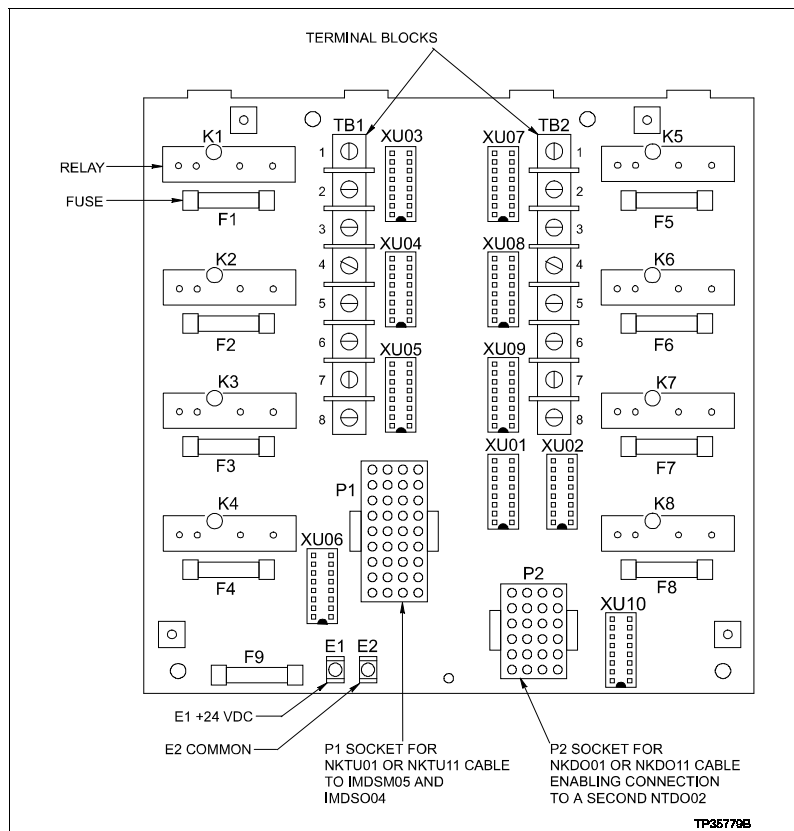

Figure 2-1. TDO Termination Unit Layout

**Dipshunt Configuration**

There are ten dipshunts on the termination unit. Figure 2-1 shows the locations of the dipshunts. Dipshunts XU01 and XU02 determine the I/O module relay control. Configure a dipshunt by either cutting straps or leaving straps uncut in certain sequences. Cut the dipshunt straps using a standard shunt cutting tool. Always cut straps completely. Install the configured dipshunt into the desired socket on the termination unit. To install a dipshunt, align the end of the dipshunt identified with the silver dot to the end of the socket having an identification mark and push the dipshunt into the socket. Be careful not to bend any pins during insertion.

**NORMAL OPERATION (XU01 AND XU02)**

Normally each I/O module output controls one relay on the termination unit. The I/O module has 16 outputs divided into two groups. Outputs one through eight belong to group A and outputs nine through 16 belong to group B. Group A controls outputs one through eight on a termination unit connected to the I/O module. The termination unit can be interconnected to a second termination unit. Group B controls the second termination unit. Table 2-1 shows the settings for dipshunts XU01 and XU02 for normal operation.

**NOTE:** To control the termination unit using I/O module group A (one through eight) outputs, install dipshunt XU01. To control the termination unit using I/O module group B (nine through 16) outputs, install dipshunt XU02. Do not install both dipshunts (XU01 and XU02) on the same termination unit.

Table 2-1. Dipshunt XU01 and XU02 Normal Operation Settings

Strap Numbers XU01 1 2 3 4 5 6 7 8	Strap Numbers XU02 1 2 3 4 5 6 7 8	Function
1 1 1 1 1 1 1 1	0 0 0 0 0 0 0 0	Normal operation dipshunt setting. I/O module group A (outputs 1 - 8) control termination unit outputs 1 - 8.
0 0 0 0 0 0 0 0	1 1 1 1 1 1 1 1	Normal operation dipshunt setting. I/O module group B (outputs 9 - 16) control termination unit outputs 1 - 8.

NOTE: 0 = open or cut strap, 1 = intact or shorted strap.

**ADVANCED APPLICATIONS (XU01 AND XU02)**

In advanced applications, a single output from the I/O module can control up to nine relays. Each I/O module can control up to 18 interconnected termination units. Figure 2-2 shows the internal circuitry of dipshunt sockets XU01 and XU02.

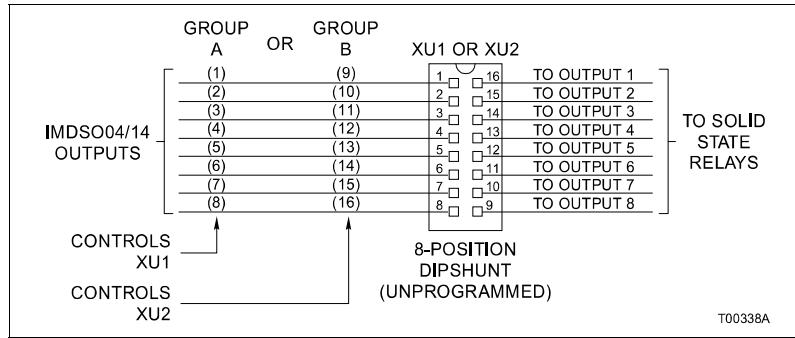

Figure 2-2. Dipshunt Socket XU01 and XU02 Internal Circuitry

There are two ways to configure the NTDO02 termination unit. Use either dipshunts or insert an adapter plug (part number 1947690\_16) into the dipshunt socket. Figures 2-3 and 2-4 show two configuration examples. Figure 2-3 shows an I/O module with each output controlling a relay. Figure 2-4 shows an example of an I/O module controlling 27 relays via four termination units using adapter plugs. In the example shown in Figure 2-4:

- I/O module output one (group A) controls nine relays.
- I/O module output two (group A) controls three relays.
- I/O module output ten (group B) controls eight relays.
- I/O module output 11 (group B) controls seven relays.

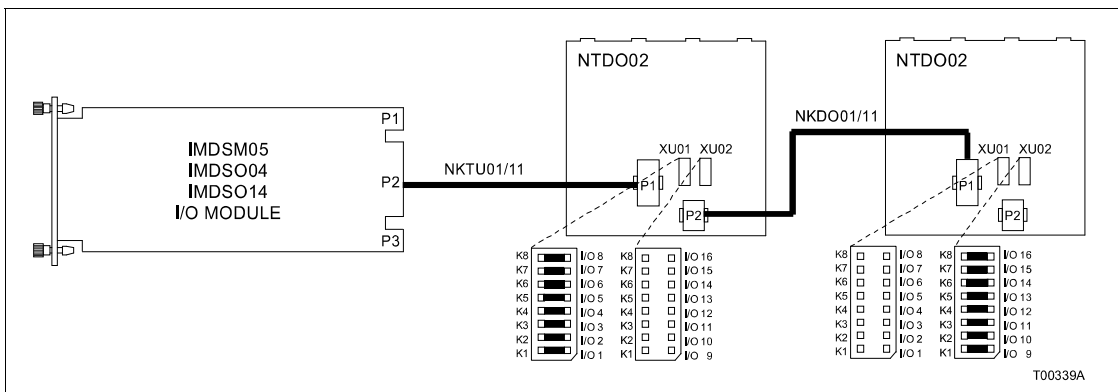

Figure 2-3. Example Configuration Using Dipshunts

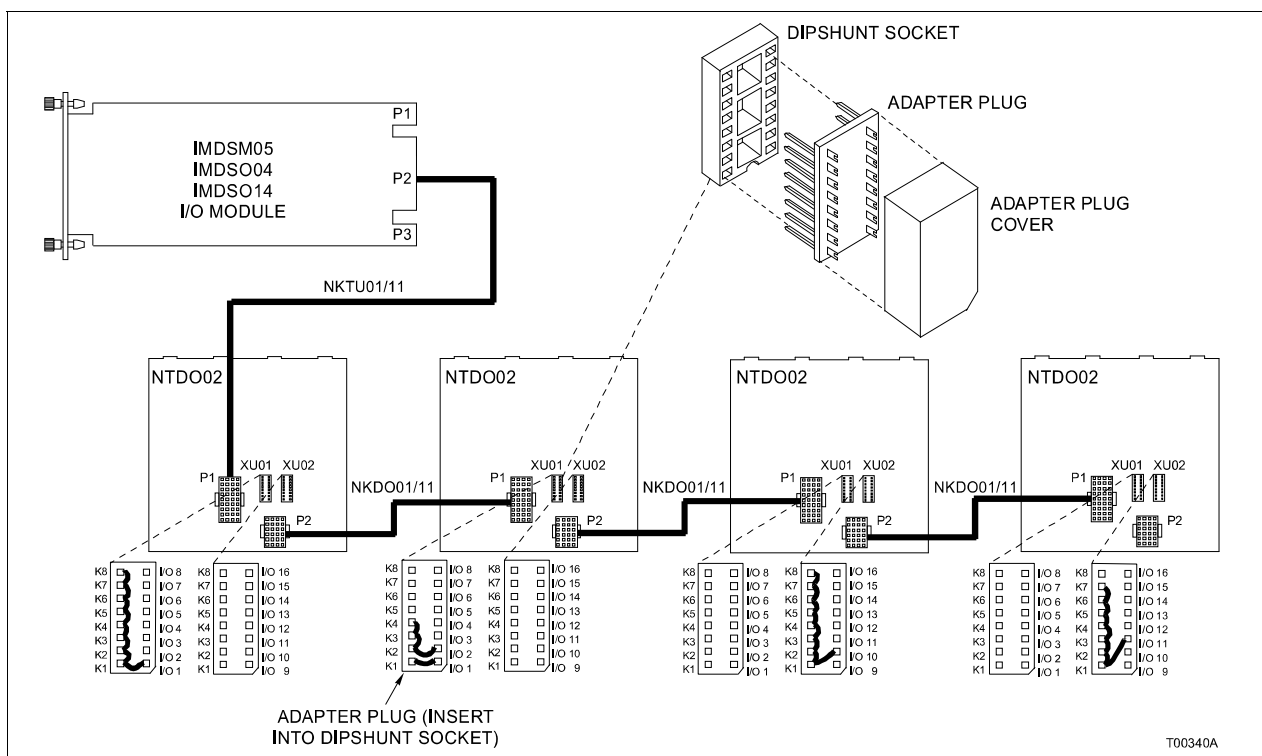

Figure 2-4. Example Configuration Using Adapter Plugs

When using the adapter plugs, jumper the I/O module outputs to the appropriate relays by soldering wire (22 to 30 gage) on the adapter plug and then inserting the adapter plug into the dipshunt socket (XU01 or XU02).

#### I/O MODULE SELECTION (XU03 THROUGH XU10)

Dipshunts XU03 through XU10 determine the type of I/O module used. Dipshunts XU03 through XU10 must be configured identically for each relay being used on all termination units connected to a particular I/O module. Table 2-2 shows the settings for dipshunts XU03 through XU10.

**NOTE:** To use any output on interconnected termination units, the corresponding dipshunt must be configured and installed on all preceding interconnected termination units. For example, if there are three interconnected termination units, XU09 on all three termination units must have a configured dipshunt installed to use output seven on the last interconnected termination unit.

Install a configured dipshunt in XU09 and XU10 to use output eight on any NTDO02 termination unit. Configuring XU09 connects 24 VDC to XU10.

Table 2-2. Dipshunt XU03 through XU10 Settings

Strap Number	Function
1 2 3 4 5 6 7 8	
1 0 0 1 0 1 1 1	Termination unit is controlled by IMDSO04 I/O module.
0 1 1 0 1 0 1 1	Termination unit is controlled by IMDSM05 I/O module.

NOTE: 0 = open or cut strap, 1 = intact or shorted strap.

Fuse Installation

<b>CAUTION</b>	<b>Use only the CSA certified fuses and relays specified in this manual. Use the correct fuse for the selected relay. Failure to use the correct relay and fuse could cause damage to equipment.</b>
<b>ATTENTION</b>	<b>N'utiliser que des fusibles et des relais accrédités ACNOR tel que spécifié dans cette notice. Utiliser le fusible approprié pour le relais en cause. L'utilisation d'un relais ou fusible inapproprié pourrait causer des dommages à l'équipement.</b>

The eight outputs on the termination unit are protected by a fuse (F1 through F8). Output one is protected by fuse F1, output two by fuse F2, etc. Fuses F1 through F8 are not provided with the termination unit. Install the correct fuse for each relay type. Table 2-3 shows the corresponding fuses and relays.

NOTE: The fuse rating may be higher than the relays current capabilities. The fuse is rated to protect the output device from damage due to a short circuit. These fuse ratings allow short duration surge currents to pass while providing protection for normal current operation.

Table 2-3. Fuse and Relay Ratings

Relay		Fuse	
Output	Part Number	Description	Part Number
120 VAC	1947684_32, 1947803_1 <sup>1</sup>	4 A (slo blo)	194776_24001
24 VDC	1947685_31	3 A	194776_13001
125 VDC	1947685_32	1 A	194776_11001

NOTE:  
1. Use part number 1947803\_1 for AC applications requiring IEEE-472-1989 surge and withstand capability.

Fuse F9 (part number 194776\_15000) is an input fuse for 24 VDC to the termination unit. Fuse F9 is used by the I/O module output switch and the solid state relay input voltage circuit. Fuse F9 is rated at 500 milliamps. Verify that fuse F9 is installed in the termination unit. If there are interconnected termination units, only the first termination unit (the one cabled directly to the I/O module) requires a fuse.

**Relay Installation**

The solid state relays must be installed in the termination unit. Select relays and fuses from Table 2-3. Each relay controls one output. The relay type installed depends on the application. Use the appropriate fuse with the relay per the listing in Table 2-3. Insert the relay into the socket on the termination unit by aligning the pins with the socket. The relay has offset pins to insure proper installation. Do not bend the pins on the relay. Secure the relay to the board by tightening the captive hold-down screw in the relay. Do not overtighten the screw.

**INSTALLING THE TERMINATION UNIT**

The termination unit is ready for installation if the dipshunts are properly installed and configured, and the relays and fuses are in place. The termination unit mounts on a standard NFTP01 Field Termination Panel as shown in Figure 2-5.

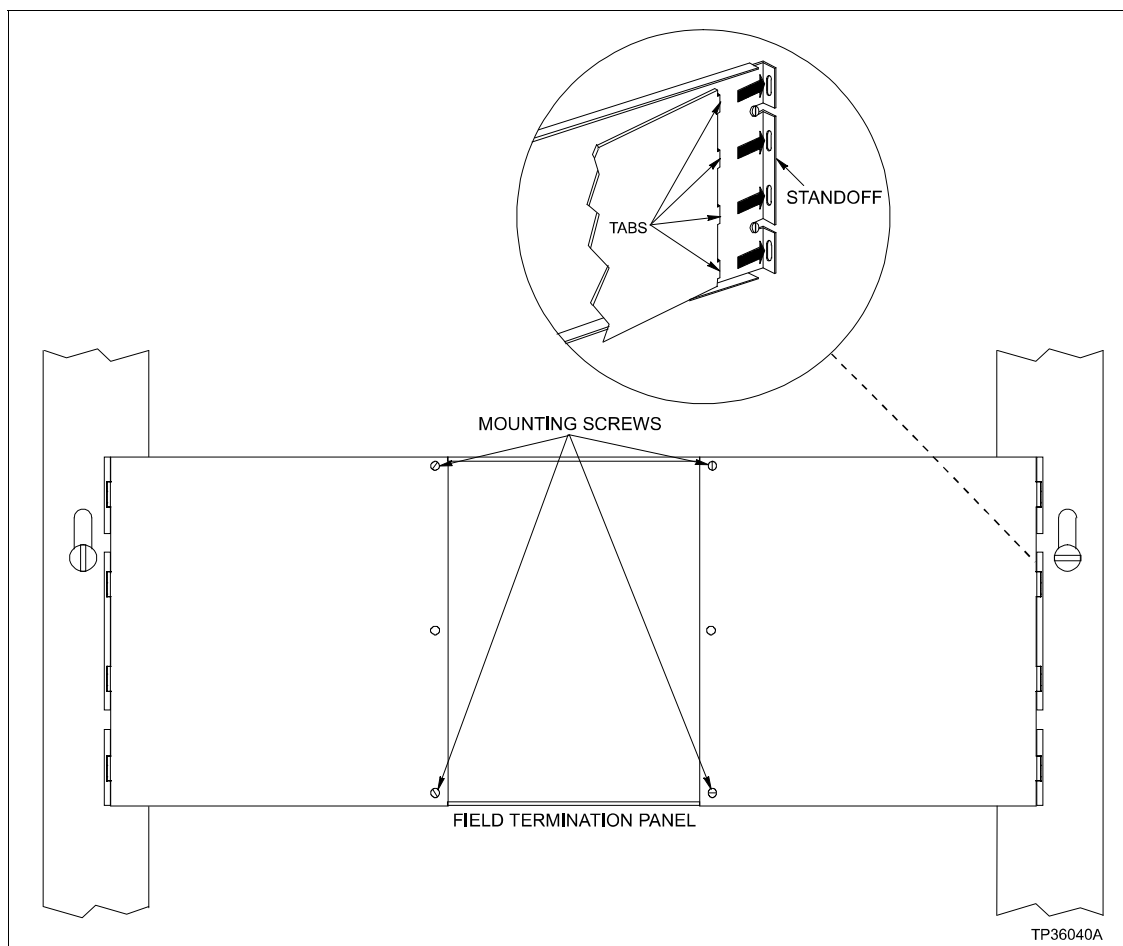

Figure 2-5. Mounting and Securing the Termination Unit

**Mounting the Termination Unit**

1. Remove the lexan® safety shield.
2. Insert the tabs of the circuit board into the proper slots of the termination panel standoff as shown in Figure 2-5 and slide the circuit board into position.
3. Secure the termination unit circuit board to the field termination panel with two number 10 self-tapping screws (Figure 2-5).

**Termination Unit Cables**

After mounting the termination unit to the field termination panel, install the termination cables. Table 2-4 lists the cables, their applications, connector assignments and maximum length restrictions. Figure 2-6 shows a diagram of cable connections to the I/O module and termination unit.

Table 2-4. Cable Applications

Nomenclature/Description	Application	NTDO02 Connector	Max. Length m (ft)
NKTU01 (PVC jacket) NKTU11 (non-PVC jacket) termination cable	Connects the TDO termination unit to the I/O module	P1	30 (100)
NKDO01 (PVC jacket) NKDO11 (non-PVC jacket) interconnection cable	Interconnects TDO termination units	P1 and P2	1.5 (5.0)

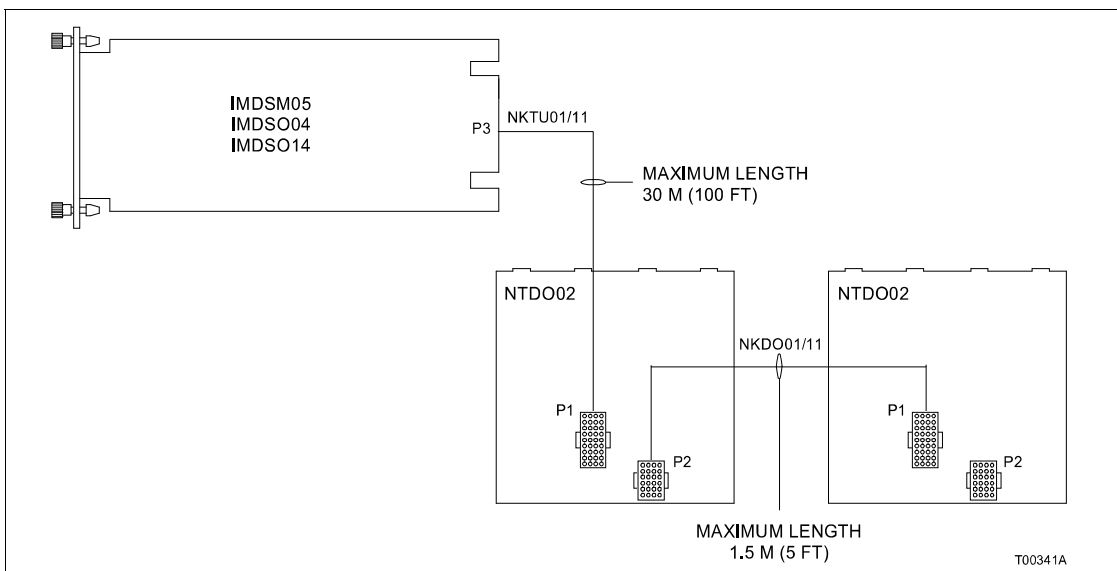

Figure 2-6. Cable Connections

© Lexan is a registered trademark of General Electric Company.

To install the termination unit cable:

<b>CAUTION</b>	<b>Remove a module from its assigned slot before installing or removing a cable assigned to that slot. Failure to do so could result in damage to the module.</b>
<b>ATTENTION</b>	<b>Avant de retirer ou de brancher un câble, retirez le module logé dans la coulisse correspondante. Autrement, le module risque d'être endommagé.</b>

1. Install the J2 connector of the NKTU01 or NKTU11 Termination Unit Cable in the module mounting unit backplane slot assigned to the I/O module.
2. Insert the J1 connector of the NKTU01 or NKTU11 Termination Unit Cable into P1 of the termination unit.

When using interconnected termination units use an NKDO01 or NKDO11 interconnection cable. To install the interconnection cable:

1. Connect the 24-pin connector of the interconnection cable to P2 of the first interconnected termination unit. The first interconnected termination unit is connected to the I/O module.
2. Connect the 36-pin connector of the interconnection cable to P1 of the second interconnected termination unit.
3. Repeat for all interconnected termination units (up to 18).

### **Power Wiring**

There are two terminals that provide power and ground connections. See Figure 2-1 for terminal locations. Terminal E1 is the 24 VDC power connection. Terminal E2 is the I/O common connection. To connect the power wiring:

<b>CAUTION</b>	<b>It is strongly recommended that all power (cabinet, I/O, etc.) be turned off before doing any wiring. Verify all connections before applying power. Failure to observe these precautions could result in equipment damage.</b>
<b>ATTENTION</b>	<b>Il est fortement recommandé de débrancher toute source d'alimentation (armoire, E/S, etc.) avant d'effectuer du travail au câblage. Vérifiez toutes les connexions avant de rétablir l'alimentation. Ces précautions permettent d'éviter des dommages à l'équipement.</b>

1. Attach a 14 AWG wire from the 24 VDC power distribution source to the E1 terminal on the termination unit.

2. Attach a 14 AWG wire from the I/O common to the E2 terminal of the termination unit.

**NOTE:** All interconnected NTDO02 termination units derive 24 VDC power for their outputs from the E1 connector on the first termination unit. Therefore, when connecting 24 VDC power and I/O common to interconnected termination units, connect 24 VDC power and I/O common to the first termination unit only.

**Terminal Block Wiring**

See Figure 2-7 for terminal block assignments and terminal polarity. Field wiring requirements will depend on the application. Refer to the **Site Planning and Preparation** instruction for specific information on field wiring installation requirements (i.e., spacing, isolation, etc.). Connect the wiring from the terminals to the output devices. Proper wiring polarity is required for relay signals.

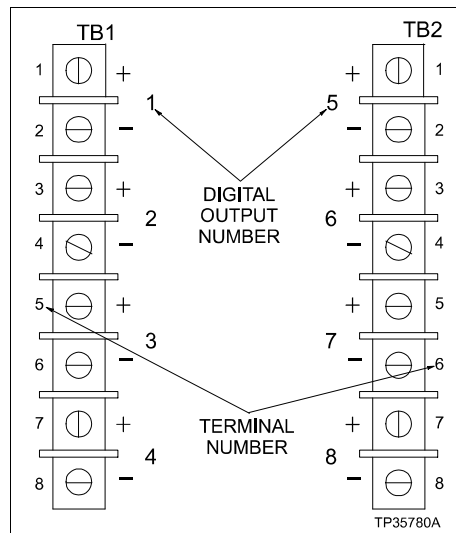

Figure 2-7. Terminal Assignments

**INSTALLATION COMPLETE**

The termination unit is ready for operation if:

1. The fuses are installed.
2. The relays are installed.
3. The dipshunts or plug adapters are installed.
4. The termination unit is installed on the field termination panel.
5. The cables are connected.

6. Power wiring is connected and applied to the termination unit.
7. Terminal block wiring is connected to the termination unit and field device.
8. The lexan safety shield is installed.

---

## SECTION 3 - MAINTENANCE

---

### INTRODUCTION

**WARNING**

There are exposed electrical connections inside the cabinet. These exposed electrical connections present a shock hazard that can cause injury or death.

**AVERTISSEMENT**

L'intérieur de cette armoire contient des bornes électriques qui sont à découvert. Ces bornes électriques à découvert constituent un risque de choc qui pourrait causer blessure ou même la mort.

**WARNING**

Never clean electrical parts or components with live power present. Doing so exposes you to an electrical shock hazard.

**AVERTISSEMENT**

Ne jamais nettoyer des pièces ou composants électriques dont les circuits sont sous tension; les circuits alimentés pourraient causer un choc électrique.

**WARNING**

If input or output circuits are a shock hazard after disconnecting system power at the power entry panel, then the door of the cabinet containing these externally powered circuits must be marked with a warning stating that multiple power sources exist.

**AVERTISSEMENT**

Si des circuits d'entrée ou de sortie sont alimentés à partir de sources externes, ils présentent un risque de choc électrique même lorsque l'alimentation du système est débranchée du panneau d'entrée l'alimentation. Le cas échéant, un avertissement signalant la présence de sources d'alimentation multiples doit être apposé sur la porte de l'armoire.

**WARNING**

Wear eye protection whenever working with cleaning solvents. When removing solvents from printed circuit boards using compressed air, injury to the eyes could result from splashing solvent as it is removed from the printed circuit board.

**AVERTISSEMENT**

Des lunettes de protection devraient être portées lors de travail avec des solvants nettoyants. Lorsqu'on enlève les solvants des circuits imprimés à l'aide d'air comprimé, les éclaboussures de solvant pourraient causer des blessures aux yeux.

The reliability of any stand-alone product or control system is affected by the maintenance of the equipment. Bailey Controls Company strongly recommends that all equipment users practice a preventive maintenance program that will keep the equipment operating at an optimum level.

This section presents procedures that can be performed on-site. These preventive maintenance procedures should be used as guidelines to assist in establishing good preventive maintenance practices. Select the minimum steps required to meet the cleaning needs of your system.

Personnel performing preventive maintenance should meet the following qualifications.

- Should be qualified electrical technicians or engineers that know the proper use of test equipment.
- Should be familiar with the NTDO02 Digital Output Termination Unit, have experience working with process control systems, and know what precautions to take when working on live electrical systems.

---

**PREVENTIVE MAINTENANCE SCHEDULE**

Table 3-1 is the preventive maintenance schedule for the termination unit. The table lists the preventive maintenance tasks in groups according to their specified maintenance interval. Some tasks in Table 3-1 are self explanatory. Instructions for tasks that require further explanation are covered under **PREVENTIVE MAINTENANCE PROCEDURES**.

**NOTE:** The preventive maintenance schedule is for general purposes only. Your application may require special attention.

*Table 3-1. Preventive Maintenance Schedule*

Task	Frequency
Check the cabinet air filters. Clean or replace them as necessary. Check the air filter more frequently in excessively dirty environments.	3 months
Check cabinet and termination unit for dust. Clean as necessary using an antistatic vacuum.	
Check the termination unit circuit board and cable connections, giving particular attention to power contacts. Clean as necessary. See procedure.	12 months
Complete all tasks in this table.	Shutdown

---

**EQUIPMENT AND TOOLS REQUIRED**

Following are the tools and equipment required for maintenance procedures.

- Antistatic vacuum.
- Clean, lint free cloth.
- Compressed air.
- Flathead screwdriver suitable for terminal blocks.

- Foam tipped swab.
- Isopropyl alcohol (99.4 percent electronic grade).
- Natural bristle brush.
- Phillips screwdriver for safety shield and relay mounting screws.
- Small needle nose pliers.

---

**PREVENTIVE MAINTENANCE PROCEDURES**

This section covers tasks from Table 3-1 that require specific instruction or further explanation. The tasks and instructions covered are:

- Cleaning printed circuit boards.
- Checking signal, power and ground connections.

---

**Printed Circuit Board Cleaning**

There are two circuit board cleaning procedures in this section. These procedures cover circuit board cleaning and washing, and cleaning connectors. Use the procedures that meet the needs of each circuit board. Remove all dust, dirt, oil, corrosion or any other contaminant from the circuit board.

Do all cleaning and handling of the printed circuit boards at static safe work stations. Always observe the steps under **SPECIAL HANDLING** in Section 2 when handling printed circuit boards.

---

**General Cleaning and Washing**

If the printed circuit board needs minor cleaning, remove dust and residue from the printed circuit board surface using clean, dry, filtered compressed air or an antistatic vacuum cleaner.

Another method of washing the printed circuit board is:

1. Clean the printed circuit board by spraying or wiping the board with a foam tipped swab wetted in isopropyl alcohol (99.4% electronic grade).
2. When the circuit board is clean, remove excess solvent by using compressed air to blow it free of the circuit board.

---

### *Checking Connections*

Check all signal wiring, power and ground connections within the cabinet to verify their integrity. When checking connections, always turn a screw, nut or other fastening device in the direction to tighten only. If the connection is loose, it will be tightened. If the connection is tight, the tightening action will verify that it is secure. There must not be any motion done to loosen the connection.

**NOTE:** Power to the cabinet should be off while performing this preventive maintenance task. If there are externally powered circuits connected to the termination unit that are a shock hazard, turn off power to these externally powered circuits before checking I/O wiring.

1. Verify that all field wiring connections are secure.
2. Check all cable connections.
3. Check power faston connections. If loose, slightly squeeze with small needle nose pliers to provide a snug fit.

---

## SECTION 4 - REPAIR/REPLACEMENT PROCEDURES

---

### INTRODUCTION

**CAUTION**

Use only the CSA certified fuses and relays specified in this manual. Use the correct fuse for the selected relay. Failure to use the correct relay and fuse could cause damage to equipment.

**ATTENTION**

N'utiliser que des fusibles et des relais accrédités ACNOR tel que spécifié dans cette notice. Utiliser le fusible approprié pour le relais en cause. L'utilisation d'un relais ou fusible inapproprié pourrait causer des dommages à l'équipement.

Repair procedures are limited to fuse, relay and termination unit replacement.

---

### FUSE REPLACEMENT

If a fuse opens, replace it with a fuse having an equivalent rating. Table 4-1 describes the fuses and lists their Bailey part numbers. To replace a fuse:

1. Turn off power to the cabinet.
2. Remove the lexan safety shield.
3. Remove the blown fuse from its holder.
4. Replace the blown fuse with an equivalent fuse.
5. Install the lexan safety shield.
6. Turn on power to the cabinet.

Table 4-1. Parts List

Part Number	Description	Part Number	Description
1946715_8	Dipshunt	194776_11001	Fuse, 1 A, 250 V
1947684_32	Relay, 120 VAC	194776_13001	Fuse, 3 A, 250 V
1947685_31	Relay, 24 VDC	194776_15000	Fuse, 500 mA, 250 V
1947685_32	Relay, 125 VDC	194776_24001	Fuse, 4 A, 250 V (slo blo)
1947690_16	Plug adapter	1947803_1 <sup>1</sup>	Relay, 120 VAC
1947691_16	Plug adapter cover		

**NOTE:**

1. Use part number 1947803\_1 for AC applications requiring IEEE-472-1989 surge and withstand capability.