

---

*The Tricon fault-tolerant controller is based on a Triple-Modular Redundant (TMR) architecture.*

## Introduction

---

### What Is Fault-Tolerant Control?

A fault-tolerant control system identifies and compensates for failed control system elements and allows repair while continuing an assigned task without process interruption. A high-integrity control system such as the Tricon™ controller is used in critical process applications that require a significant degree of safety and availability.

### What Is the Tricon Controller?

The Tricon is a state-of-the-art controller that provides fault tolerance by means of Triple-Modular Redundant (TMR) architecture. TMR integrates three isolated, parallel control systems and extensive diagnostics in one control system. The system uses two-out-of-three voting to provide high-integrity, error-free, uninterrupted process operation.

The Tricon controller uses three identical channels. Each channel independently executes the control program in parallel with the other two channels. Specialized hardware/software voting mechanisms qualify and verify all digital inputs and outputs from the field, while analog inputs are subject to a mid-value selection process.

Because each channel is isolated from the others, no single-point failure in any channel can pass to another. If a hardware failure occurs on one channel, the other channels override it. Meanwhile, the faulting module can easily be removed and replaced, while the



**The Tricon Fault-Tolerant Controller**

controller is online, without interrupting the process.

Setting up control programs is simplified with the triplicated Tricon system, because it operates as a single control system from the user's point of view. The user terminates sensors and actuators at a single wiring terminal and programs the Tricon controller with one

set of control program logic. The Tricon controller manages the rest!

Extensive diagnostics on each channel, module, and functional circuit immediately detect and report operational faults by means of indicators or alarms.

All diagnostic fault information is accessible by the control program and the operator. The program or the operator can use diagnostic data to modify

# Introduction

---

control actions or direct maintenance procedures.

Other key features of the Tricon controller that ensure the highest possible system integrity are:

- Ability to operate with three, two, or one Main Processors before shutdown
- Fully implemented and transparent triplication
- Comprehensive system diagnostics
- Complete range of I/O modules
- Dual and single I/O modules for safety-critical points with a limited need for availability
- Remote I/O up to 7.5 miles (12 kilometers) away from the MPs
- Simple, online module repair
- Unsurpassed reliability and availability

## What Are Typical User Applications?

Each day the Tricon controller supplies increased safety, reliability, and availability to a worldwide installed base. The following are a few typical applications. For more information on how a Tricon controller can add value to your applications, ask your sales representative for additional documentation and customer references.

### Emergency Safety Shutdown (ESD)

The Tricon controller provides continuous protection for safety-critical units in refineries, petrochemical/chemical plants, and other industrial processes. For example, in reactor and compressor units, plant-trip signals—for pressure, product feed rates, expander pressure equalization and temperature—are monitored, and shutdown actions taken if an upset condition occurs. Traditional

shutdown systems—implemented with mechanical or electronic relays—provide shutdown protection but can also cause dangerous nuisance trips.

The Tricon controller increases system integrity, providing automatic detection and verification of field sensor integrity, integrated shutdown and control functionality, and direct connection to the supervisory data highway for continuous monitoring of safety-critical functions.

### Boiler Flame Safety

Process steam boilers function as a critical component in most refinery applications. Protection of the boiler from upset conditions, safety interlock for normal startup and shutdown, and flame-safety applications are combined by one integrated Tricon system. In traditional applications, these functions had to be provided by separate, non-integrated components. But with the fault-tolerant, fail-safe Tricon controller, the boiler operations staff can use a critical resource more productively while maintaining safety at or above the level of electromechanical protection systems.

### Turbine Control Systems

The control and protection of gas or steam turbines requires high integrity as well as safety. The continuous operation of the fault-tolerant Tricon controller provides the turbine operator with maximum availability while maintaining equivalent levels of safety. Speed control as well as start-up and shutdown sequencing are implemented in a single integrated system. Unscheduled outages are avoided by using *hot-spares* for the I/O modules. If a fault occurs in a module, a replacement module is automatically activated without operator intervention.

## Offshore Fire and Gas Protection

The protection of offshore platforms from fire and gas threats requires continuous availability as well as reliability. The Tricon controller provides this availability through *online replacement* of faulty modules. Faults in individual modules, field wiring, and sensors are managed automatically by built-in diagnostics. Analog fire and gas detectors are connected directly to the Tricon, eliminating the need for trip amps. An operator interface monitors fire and gas systems as well as diagnostics for the Tricon controller and its attached sensors. Traditional fire and gas panels can be replaced with a single integrated system, saving costly floor space while maintaining high levels of safety and availability.

## What Is TriStation 1131?

TriStation™ 1131 Developer's Workbench is an integrated tool for developing, testing and documenting control programs that execute in the Tricon controller. The TriStation 1131 software complies with the IEC 61131 International Standard for Programmable Controllers and follows the Microsoft® Windows® guidelines for graphical user interfaces.

## What About Communication Capabilities?

Optional modules enable the Tricon controller to communicate with other Triconex® controllers and with other hosts such as:

- Modbus masters and slaves
- Distributed Control Systems (DCS)
- Operator workstations
- Host computers using Ethernet (802.3) protocol

For more information, see “Communication Capabilities” on page 67.

The Tricon controller is designed with a fully triplicated architecture throughout, from the input modules through the Main Processors (MPs) to the output modules.

## Theory of Operation

Triple Modular Redundant (TMR) architecture ensures fault tolerance and provides error-free, uninterrupted control in the presence of either hard failures of components or transient faults from internal or external sources.

Every I/O module houses the circuitry for three independent channels. Each channel on the input modules reads the process data and passes that information to its respective Main Processor. The three Main Processors communicate with each other using a proprietary high-speed bus system called the TriBus.

sate for errors that occur between the Main Processor and the final output driven to the field.

Each I/O slot can contain two identical I/O modules, which means if a fault is detected on one module, control is automatically switched to the healthy module. A faulty module can also be replaced online when only one module is installed in the slot. In this case, a healthy module is inserted in the spare slot and the control is switched to this module, which allows the faulty module to be pulled and sent for repair.

As each input module is polled, the appropriate channel of the I/O bus transmits new input data to the Main Processor. The input data is assembled into a table in the Main Processor and is stored in memory for use in the hardware voting process.

The individual input table in each Main Processor is transferred to its neighboring Main Processors over the TriBus. During this transfer, hardware voting takes place. The TriBus uses a direct memory access programmable device to synchronize, transmit, vote, and compare data among the three Main Processors.

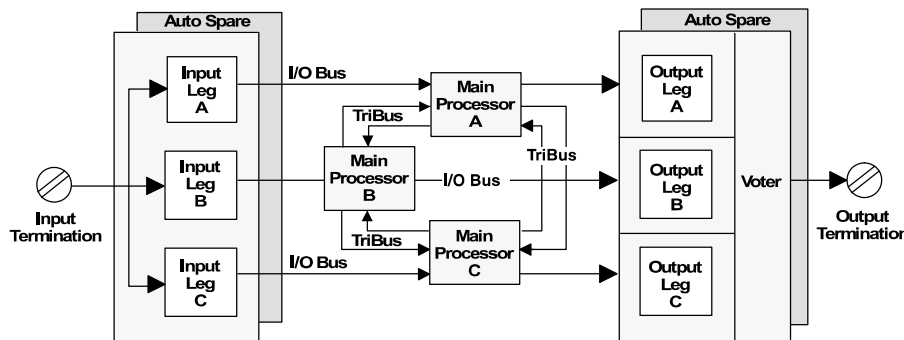

**Simplified Tricon System Architecture**

Once per scan, the Main Processors synchronize and communicate with their neighbors over the TriBus. The TriBus votes digital input data, compares output data, and sends copies of analog input data to each Main Processor. The Main Processors execute the control program and send outputs generated by the control program to the output modules. The Tricon controller votes the output data on the output modules as close to the field as possible to detect and compen-

### Main Processor Modules

A Tricon controller contains three Main Processor modules. Each Main Processor controls a separate channel of the system and operates in parallel with the other Main Processors. A dedicated I/O Processor on each Main Processor manages the data exchanged between the Main Processor and the I/O modules. A triplicated I/O bus, located on the chassis backplane, extends from chassis to chassis by means of I/O bus cables.

If a disagreement occurs, the signal value found in two out of three tables prevails, and the third table is corrected accordingly. One-time differences which result from sample timing variations are distinguished from a pattern of differing data. Each Main Processor maintains data about necessary corrections in local memory. Any disparity is flagged and used at the end of the scan by the Tricon controller built-in fault analyzer routines to determine whether a fault exists on a particular module.

The Main Processors put corrected data into the control program. The 32-bit main microprocessor executes the control program in parallel with the neighboring Main Processor modules.

The control program generates a table of output values which are based on the table of input values according to customer-defined rules built into the control program. The I/O Processor on

# Theory of Operation

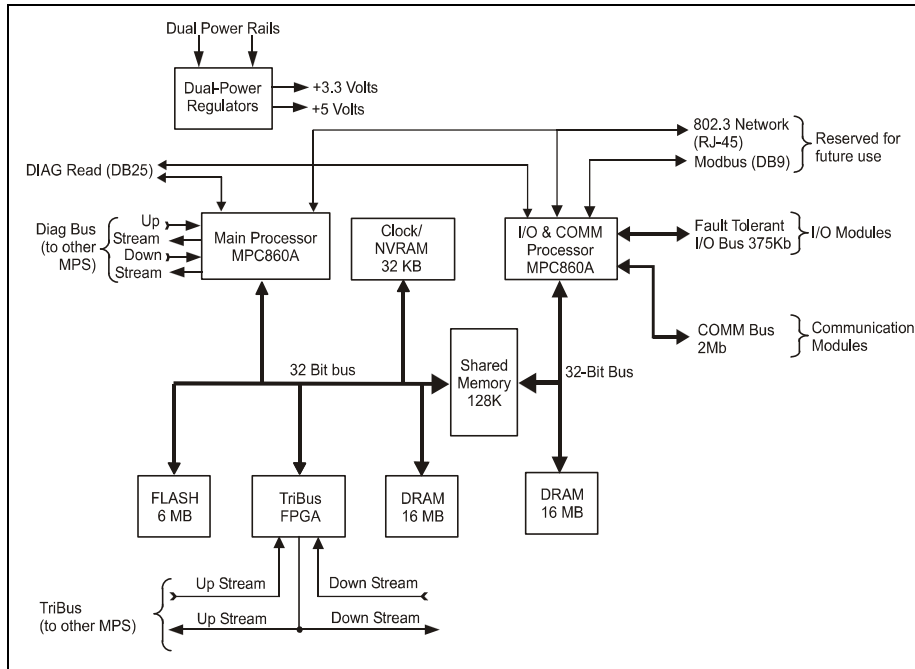

**Main Processor (Model 3008) Architecture**

each Main Processor manages the transmission of output data to the output modules by means of the I/O bus.

Using the table of output values, the I/O Processor generates smaller tables, each corresponding to an individual output module in the system. Each small table is transmitted to the appropriate channel of the corresponding output module over the I/O bus. For example, Main Processor A transmits the appropriate table to Channel A of each output module over I/O Bus A. The transmittal of output data has priority over the routine scanning of all I/O modules. The I/O Processor manages the data exchanged between the Main Processors and the communication modules using the communication bus which supports a broadcast mechanism.

Main Processors receive power from dual Power Modules and power rails in the Main Chassis. A failure on one

Power Module or power rail does not affect system performance.

## Bus Systems and Power Distribution

Three triplicated bus systems are etched on the chassis backplane: the TriBus, the I/O bus, and the communication bus.

### TriBus

The TriBus consists of three independent serial links which synchronizes the Main Processors at the beginning of a scan, and performs either of these functions:

- Transfers I/O, diagnostic, and communication data.
- Compares data and flags disagreements of output or memory data from the previous scan.

An important feature of Tricon controller architecture is the use of a single transmitter to send data to both the upstream and downstream Main

Processors, which ensures the same data is received by the upstream processor and downstream processor.

### I/O Bus

Each I/O module transfers signals to or from the field through its associated field termination assembly. Two positions in the chassis tie together as one logical slot. Termination cables are tied to panel connectors at the top of the backplane. Each connection extends from the termination module to both active and hot-spare I/O modules, which means both the active module and the hot-spare module receive the same information from the field termination wiring.

The triplicated I/O bus transfers data between the I/O modules and the Main Processors at 375 kilobits per second. The I/O bus is carried along the bottom of the backplane. Each channel of the I/O bus runs between one Main Processor and the corresponding channels on the I/O module. The I/O bus extends between chassis using a set of three I/O bus cables.

### Communication Bus

The communication (COMM) bus runs between the Main Processors and the communication modules at 2 megabits per second.

### Power Distribution

Power for the chassis is distributed across two independent power rails and down the center of the backplane. Each module in the chassis draws power from both power rails through dual power regulators. There are four sets of power regulators on each input and output board: one set for each channel (A, B, and C) and one set for the status indicators.

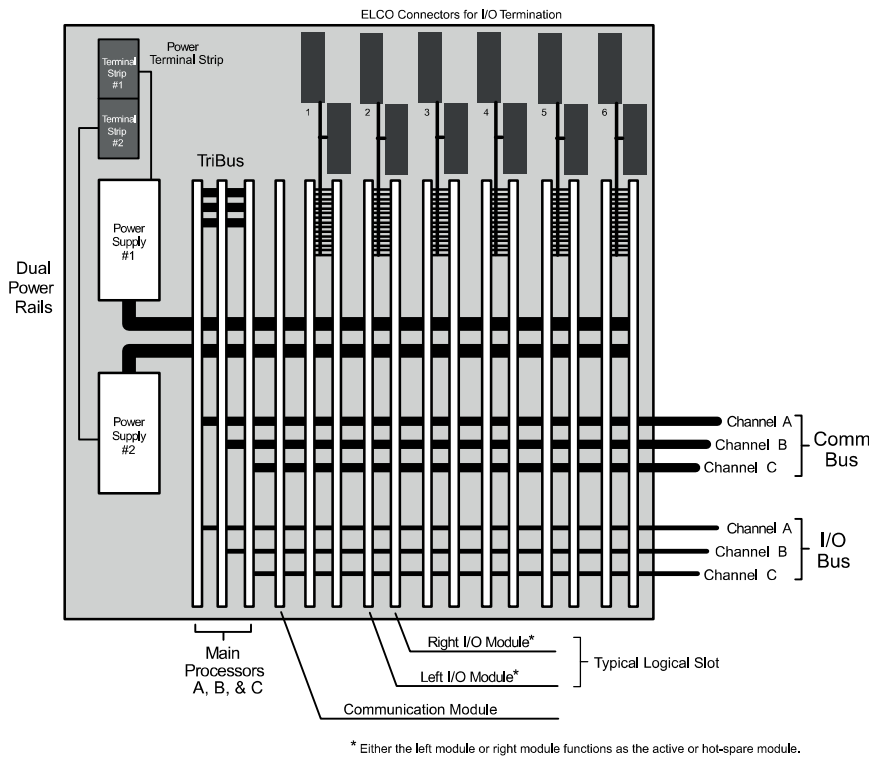

**Tricon Bus Systems and Power Distribution**

### Field Signals

Each I/O module transfers signals to or from the field through its associated field termination panel. Two positions in the chassis tie together as one logical slot. The first position holds the active I/O module and the second position holds the hot-spare I/O module. Termination cables are connected to the top of the backplane. Each connection extends from the termination panel to both active and hot-spare I/O modules. Therefore, both the active module and the hot-spare module receive the same information from the field termination wiring.

### Digital Input Modules

The Tricon controller supports two basic types of Digital Input Modules: TMR and Single. The following paragraphs describe Digital Input Modules

in general, followed by specifics for TMR and Single modules.

Every Digital Input Module houses the circuitry for three identical channels (A, B, and C). Although the channels reside on the same module, they are completely isolated from each other and operate independently. A fault on one channel cannot pass to another. In addition, each channel contains an 8-bit microprocessor called the I/O communication processor, which handles communication with its corresponding Main Processor.

Each of the three input channels asynchronously measures the input signals from each point on the input module, determines the respective states of the input signals, and places the values into input tables A, B, and C respectively. Each input table is regularly interrogated over the I/O bus by the I/O

communication processor located on the corresponding Main Processor. For example, Main Processor A interrogates Input Table A over I/O Bus A.

On TMR Digital Input Modules, all critical signal paths are 100 percent triplicated for guaranteed safety and maximum availability. Each channel conditions signals independently and provides isolation between the field and the Tricon controller. (The Model 3504E High-Density Digital Input Module is an exception—it has no channel-to-channel isolation.)

DC models of the TMR Digital Input Modules can self-test to detect stuck-ON conditions where the circuitry cannot tell whether a point has gone to the OFF state. Because most safety systems use a de-energize-to-trip setting, the ability to detect the Off state is an important feature. To test for stuck-ON inputs, a switch within the input circuitry is closed to allow a zero input (Off) to be read by the optical isolation circuitry. The last data reading is frozen in the I/O Processor while the test is running.

On Single Digital Input Modules, only those portions of the signal path which are required to ensure safe operation are triplicated. Single modules are optimized for those safety-critical applications where low cost is more important than maximum availability. Special self-test circuitry detects all stuck-On and stuck-Off fault conditions within the non-triplicated signal conditioners in less than half a second. This is a mandatory feature of a fail-safe system, which must detect all faults in a timely manner and, upon detection of an input fault, force the measured input value to the safe state. Because the Tricon is optimized for de-energize-to-trip applications, detection of a fault in the input circuitry forces to Off (the de-energized state) the value reported to the Main Processors by each channel.

# Theory of Operation

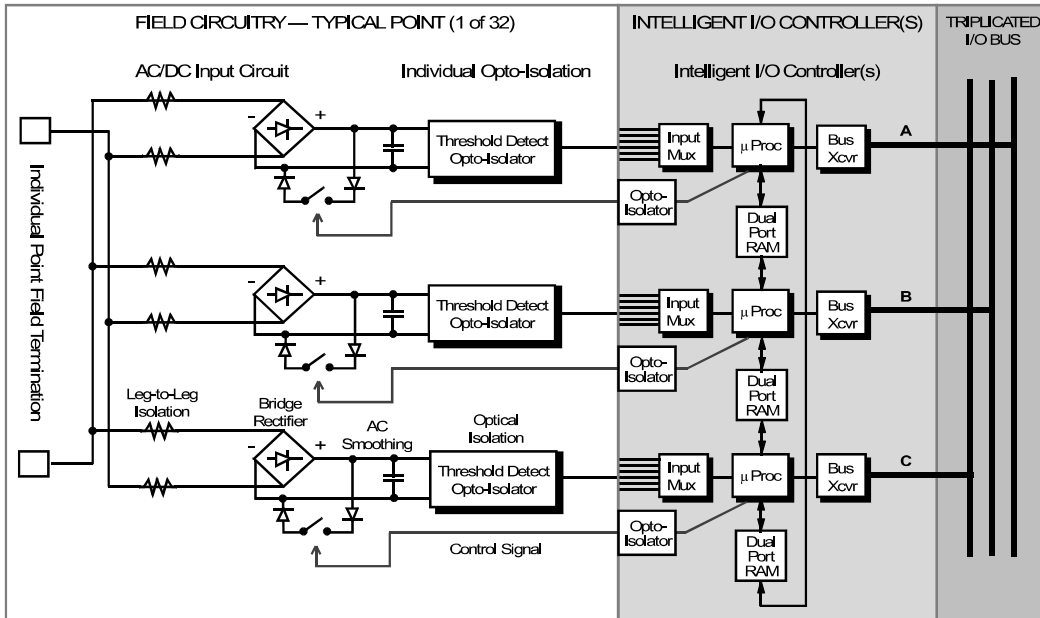

Architecture of TMR Digital Input Module with Self-Test (DC Model)

channels B and C, or channels A and C command them to close—in other words, 2-out-of-3 drivers voted On. The quadruplicated voter circuitry provides multiple redundancy for all critical signal paths, guaranteeing safety and maximum availability.

Each type of Digital Output Module executes a particular Output Voter Diagnostic (OVD) for every point. Loopback on the module allows each microprocessor to read the output value for the point to determine whether a latent fault exists within the output circuit.

## Digital Output Modules

There are four basic types of Digital Output Modules: dual, supervised, DC voltage and AC voltage.

The following paragraphs describe Digital Output Modules in general, followed by specifics for the four types.

Every Digital Output Module houses the circuitry for three identical, isolated channels. Each channel includes an I/O microprocessor which receives its output table from the I/O communication processor on its corresponding Main Processor. All of the Digital Output Modules, except the dual DC modules, use a patented quadruplicated output circuitry, referred to as *Quad Voter*, which votes on the individual output signals just before they are applied to the load. This

voter circuitry is based on parallel-series paths which pass power if the drivers for channels A and B, or

point to determine whether a latent fault exists within the output circuit.

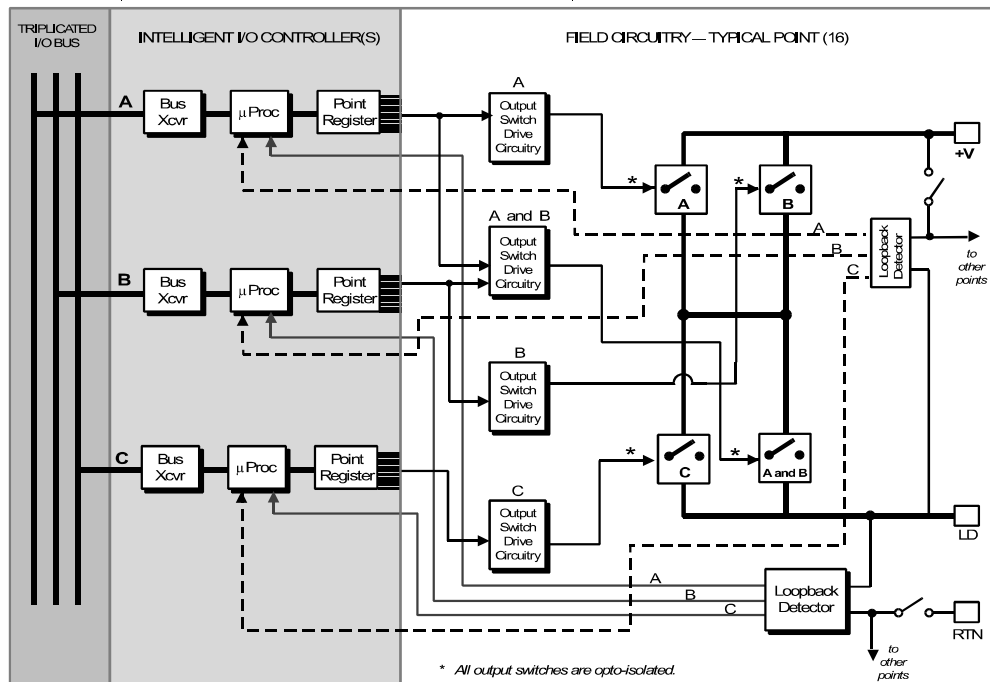

Architecture of 16-Point Supervised Digital Output Module

## Analog Input Modules

On an Analog Input Module, each of the three channels asynchronously measures the input signals and places the results into a table of values. Each of the three input tables is passed to its associated Main Processor module using the I/O bus. The input table in each Main Processor is transferred to its neighbors across the TriBus. The middle value is selected by each Main Processor, and the input table in each Main Processor is corrected accordingly. In TMR mode, the mid-value data is used by the control program; in duplex mode, the average is used.

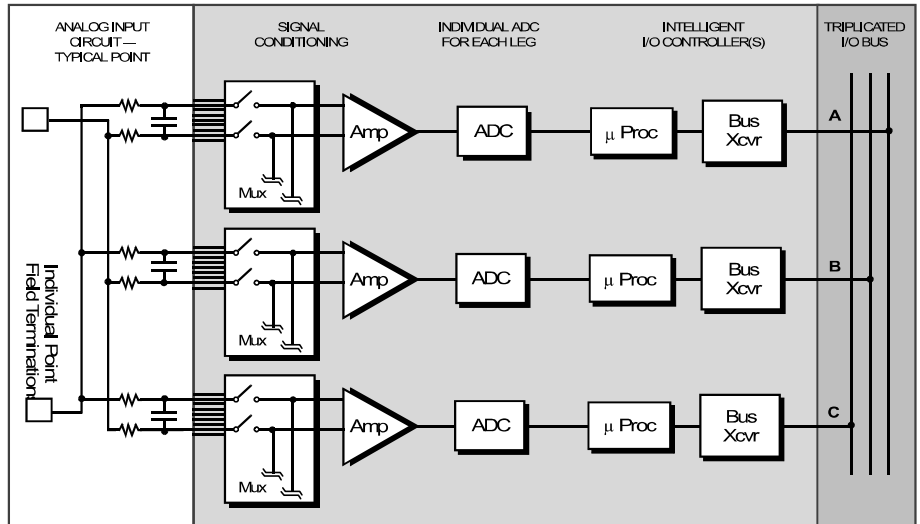

Architecture of TMR Analog Input Module

Each Analog Input Module is automatically calibrated using multiple reference voltages read through the multiplexer. These voltages determine the gain and bias that are required to adjust readings of the analog-to-digital converter (ADC).

Analog Input Modules and termination panels are available to support a wide variety of analog inputs, in both isolated and non-isolated versions: 0-5 VDC, -5 to +5 VDC, 0-10 VDC, 4-20 mA, thermocouples (types K, J, T, E), and resistive thermal devices (RTDs).

### Analog Output Module

The Analog Output Module receives three tables of output values, one for each channel from the corresponding Main Processor. Each channel has its own digital-to-analog converter (DAC). One of the three channels is selected to drive the analog outputs. The output is continuously checked for correctness by “loop-back” inputs on each point which are read by all three microprocessors. If a fault occurs in the driving channel, that channel is declared faulty and a new channel is selected to drive the field device. The

designation of “driving channel” is rotated among the channels, so that all three channels are tested.

### Field Terminations

Various termination options are available for field wiring of the Tricon chassis, including external termination panels (ETPs) and fanned-out cables.

An ETP is an electrically-passive printed circuit board to which field wiring is easily attached. An ETP passes input signals from the field to an input module or passes signals generated by an output module directly to field wiring, thereby permitting removal or replacement of the input or output module without disturbing field wiring.

A fanned-out cable is a lower-cost alternative to an ETP when using Digital Input Modules or Digital Output Modules. One end of a fanned-out cable connects to the Tricon controller backplane and the other end provides 50 fanned-out leads, each individually labeled with a pin number that matches the connector signals.

## Communication Modules

By means of the communication modules described in this section, the Tricon controller can interface with Modbus masters and slaves, other Triconex controllers in a Triconex peer-to-peer network, external hosts on Ethernet networks, and Honeywell™ and Foxboro® distributed control systems (DCS). The Main Processors broadcast data to the communication modules across the communication bus. Data is typically refreshed every scan; it is never more than two scan-times old. For more information, see “Communication Capabilities” on page 67.

### Tricon Communication Module (TCM)

The Tricon Communication Module (TCM) enables a Tricon controller to communicate with Modbus devices (masters or slaves), a TriStation 1131 PC, a network printer, other Triconex controllers, and other external devices on Ethernet networks.

Each TCM has four serial ports, two Ethernet network ports, and one debug port (for Invensys use).

# Theory of Operation

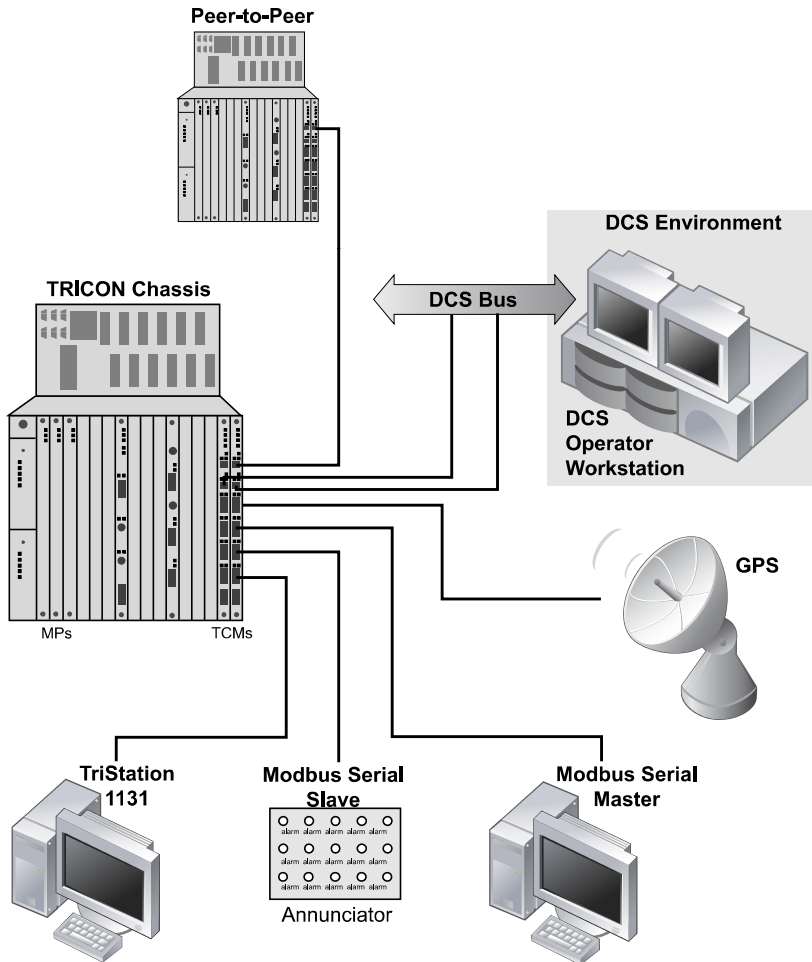

Sample of the TCM Communication Capabilities

A single Tricon controller supports up to four TCMs, which reside in two logical slots. This arrangement provides a total of sixteen serial ports and eight Ethernet network ports.

## Enhanced Intelligent Communication Module (EICM)

The EICM enables a Tricon controller to communicate with Modbus devices (masters or slaves), with a TriStation 1131 PC, and with a printer. The four serial ports are uniquely addressed and can be used for Modbus or TriStation communication at speeds up to 19.2 kilobits per second. A single Tricon High-Density controller supports up to

two EICM modules which reside in one logical slot. This arrangement provides a total of six Modbus ports, two TriStation ports, and two printer ports.

## Network Communication Module (NCM)

The NCM supports Ethernet (802.3) communication at 10 megabits per second for Triconex-proprietary protocols and applications.

The NCM also supports OPC Server which can be used by any OPC client. In addition, users can write their own applications using the TSAA protocol.

The NCMG enables time synchronization to a GPS device.

## Hiway Interface Module (HIM)

The HIM acts as an interface between a Tricon controller and a Honeywell TDC-3000 Distributed Control System (DCS) by means of the Hiway Gateway and Local Control Network (LCN). The HIM enables higher-order devices, such as computers and operator workstations, to communicate with the Tricon.

## Safety Manager Module (SMM)

The SMM acts as an interface between a Tricon controller and a Honeywell Universal Control Network (UCN), one of three principal networks of the TDC-3000 DCS. The SMM appears to the TDC-3000 as a safety node on the Universal Control Network (UCN), allowing the Tricon controller to manage process-critical points within the overall TDC-3000 environment. The SMM transmits all Tricon aliased data and diagnostic information to TDC-3000 operator workstations in display formats that are familiar to Honeywell operators.

## Advanced Communication Module (ACM)

The ACM acts as an interface between a Tricon controller and a Foxboro Intelligent Automation (I/A) Series DCS. The ACM appears to the Foxboro system as a safety node on the I/A Series<sup>®</sup> Nodebus, allowing the Tricon controller to manage process-critical points within the overall I/A DCS environment. The ACM transmits all Tricon aliased data and diagnostic information to I/A operator workstations in display formats that are familiar to Foxboro operators.

See "Product Specifications" on page 17 for specifications of the TCM, EICM, NCM, SMM, HIM, and ACM.

## HART Communication

Highway Addressable Remote Transducer protocol (HART™) is a bi-directional industrial field communication protocol used to communicate between intelligent field instruments and host systems over 4-20 mA instrumentation wiring. Invensys offers these components to enable HART communication between HART devices in the field and Configuration and Asset Management Software running on a PC:

- Model 2770H HART Analog Input Interface Module
- Model 2870H HART Analog Output Interface Module

## Power Modules

Each Tricon chassis houses two Power Modules arranged in a dual-redundant configuration. Each module derives power from the backplane and has independent power regulators for each channel. Each can support the power requirements for all the modules in the chassis in which it resides, and each feeds a separate power rail on the chassis backplane. The Power Modules have built-in diagnostic circuitry which checks for out-of-range voltages and over-temperature conditions. A short on a channel disables the power regulator rather than affecting the power bus.

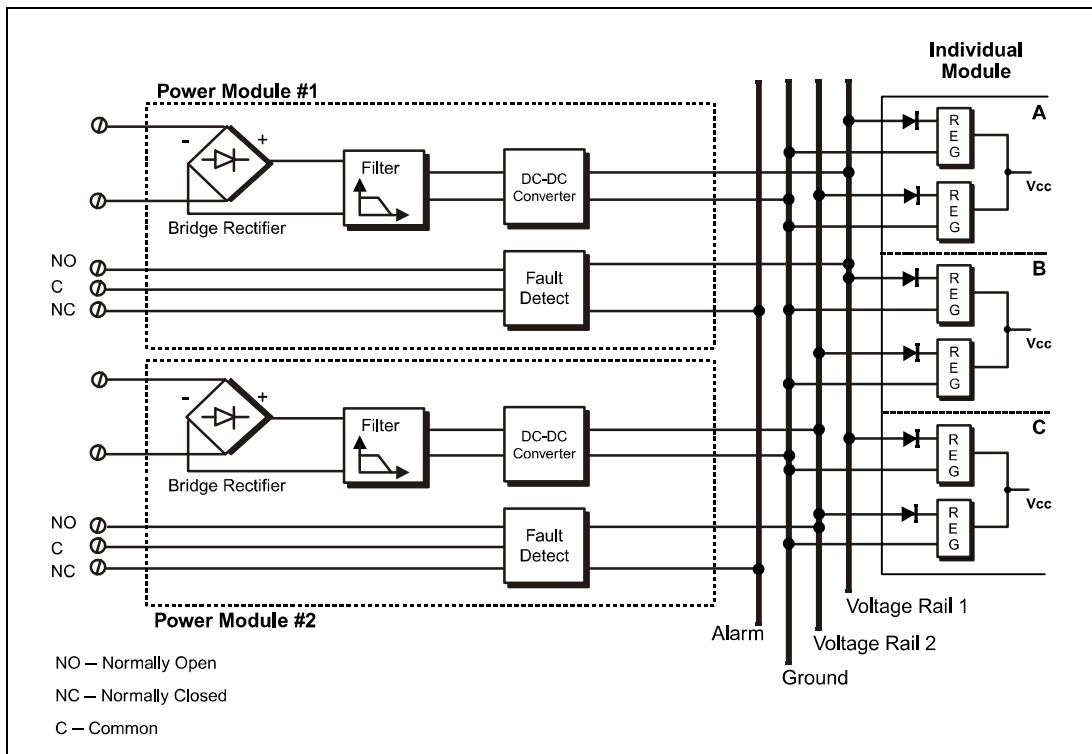

Architecture of Power Module Subsystem

---

*The Tricon controller supports a comprehensive range of modules to meet customers' needs.*

## Product Specifications

---

The Triconex product family includes a comprehensive range of modules. This section includes: a summary of the system components and their uses, a table that lists standard products and their model numbers, and a summary of specifications for each standard product in the Tricon controller family.

See the *Planning and Installation Guide for Tricon v9-v10 Systems* for complete information.

### Summary of Tricon System Components

#### Chassis

- *Main Chassis*—houses Main Processors, memory back-up batteries, communication modules and I/O modules.
- *Expansion Chassis*—for additional I/O modules with up to 100 feet (30 meters) total cable length between the Main Chassis and the last Expansion Chassis.
- *RXM Chassis*—for I/O modules up to 7.5 miles (12 kilometers) away from the Main Chassis.
- *Mechanical Keying*—Each slot in the Tricon controller is mechanically keyed to correspond with a specific type of module. This prevents the installation of modules into improper slots.

For chassis mounting and enclosure specifications, see page 31.

#### Power Supply Modules

- Provide logic power to modules in the Main, Expansion or RXM Chassis. Available in 24 VDC, 115 VAC and 230 VAC versions. The power rating of each power supply is 175 watts at 140° F (60° C).

#### Main Processors

The Main Processors execute the system diagnostics and the user-written control program.

#### Communication Modules

- *Tricon Communication Modules (TCM)* support a number of Triconex protocols and applications and user-written applications on Ethernet (802.3) networks, including TriStation, Modbus TCP, and OPC. It also supports RS-232 and RS-485 serial communication with Modbus devices, TriStation 1131, and GPS for time synchronization.
- *Enhanced Intelligent Communication Modules (EICM)* support RS-232, RS-422 and RS-485 serial communication with Modbus devices and TriStation 1131 applications.
- *Network Communication Modules (NCM)* support a number of Triconex protocols and applications and user-written applications on Ethernet (802.3) networks, including the TriStation 1131 software.
- *Safety Manager Modules (SMM)* act as an interface between a Tricon controller and a Honeywell Universal Control Network (UCN), one of three principal networks of the TDC-3000 DCS.
- *Hiway Interface Modules (HIM)* act as an interface between a Tricon controller and a Honeywell TDC-3000 Hiway Gateway and Local Control Network (LCN).
- *Advanced Communication Modules (ACM)* allow a Tricon controller to interface with a Foxboro Industrial

Automation (I/A) Series DCS and a TriStation 1131 application.

#### Fiber-Optic Remote Extender Modules (RXM)

For operation of Expansion Chassis up to 7.5 miles (12 kilometers) away from the Main Chassis, with exceptional immunity against electro-static and electro-magnetic interference.

#### Interface Modules

- *HART Analog Input Interface Modules* act as an interface between 4-20 mA analog input points from HART smart devices in the field and HART Host software running on a PC.
- *HART Analog Output Interface Modules* act as an interface between 4-20 mA analog output points from HART smart devices in the field and HART Host software running on a PC.

#### I/O Modules

- *Digital Input Modules* receive discrete signals of these nominal voltages: 115 VAC/VDC, 48 VAC/VDC, and 24 VAC/VDC. All voltages are available in TMR modules. Non-TMR modules are available in 24 VDC and 48 VDC only. Speed input and totalization modules are also available.
- *Supervised Digital Output Modules* produce discrete output signals of these nominal voltages, with diagnostic coverage of the field circuit and load device: 115 VAC, 120 VDC, 48 VDC, and 24 VDC.
- *Digital Output Modules* produce discrete output signals of these nominal voltages: 115 VAC, 120

# Product Specifications

---

VDC, 24 VDC, and 48 VDC. Dual output modules are also available.

- *Analog Input Modules* receive analog signals of these types: 0-5 VDC, -5 to +5 VDC, 0-10 VDC, and Thermocouple types J, K, T and E. Available in both isolated and DC-coupled versions.
- *Analog Output Modules* are available in these versions: eight output points at 4-20 mA; six output points at 4-20 mA and two at 20-320 mA; and four output points at -60 to 60 mA.

## Conformal Coating

Most of the Tricon hardware models in the *Planning and Installation Guide for Tricon v9-v10 Systems* and the *Field Terminations Guide for Tricon v9-v10 Systems* can be ordered with conformal coating by adding the letter “C” to the end of the standard model number.

The following equipment *cannot* be ordered with conformal coating:

- Equipment certified for use in nuclear 1E applications
- All types of cables; including interface cables, I/O bus cables, and fanned-out cables

- Blank slot covers

Neoprene dust covers are provided with external termination panels and chassis that are conformal coated. You can install the dust covers on unused external termination panel connectors and unused backplane connectors, at your discretion.

Some of the Tricon hardware with conformal coating has been certified for use in marine environments. For more information, see “Tricon Equipment Certified for Use in Marine Environments” on page 21.

# Product Specifications

Description	Model No.	See
<b>Documentation Sets</b>		
Tricon <i>Planning and Installation</i> , <i>Field Terminations</i> , and <i>Communication</i> printed manuals	Contact Invensys	
Triconex User Documentation, includes all manuals in PDF format (CD-ROM)	Contact Invensys	

a. I/O Bus Expansion Cables are available in custom lengths. Please contact Invensys for more information.

## Tricon I/O Modules

Voltage	Description	Type	Model No.	Points	For Details, See
<b>Digital Input Modules</b>					
115 VAC/VDC	Opto-Isolated, Non-Commoned	TMR	3501E/3501T	32	page 41
48 VAC/VDC	Commoned in Groups of 8, Self-Test	TMR	3502E	32	page 41
24 VAC/VDC	Commoned in Groups of 8, Self-Test	TMR	3503E	32	page 41
24/48 VDC	High-Density, DC Coupled	TMR	3504E	64	page 42
24 VDC	Low Threshold with Self-test, Commoned	TMR	3505E	32	page 41
24 VDC	Single, Opto-Isolated, Commoned	Single	3564	64	page 42
Pulse Input	Differential, AC Coupled	TMR	3511	8	page 43
Pulse Totalizer	Opto-isolated, Non-commoned	TMR	3515	32	page 44
<b>Digital Output Modules</b>					
115 VAC	Opto-Isolated, Non-commoned	TMR	3601E/3601T	16	page 45
120 VDC	Opto-Isolated, Non-commoned Opto-Isolated, Commoned	TMR	3603B, 3603E/3603T	16	page 45
24 VDC	Opto-Isolated, Non-commoned	TMR	3604E	16	page 45
48 VDC	Opto-Isolated, Non-commoned	TMR	3607E	16	page 45
115 VAC	Galvanically Isolated, Commoned., Supv.	TMR	3611E	8	page 47
48 VDC	Galvanically Isolated, Commoned, Supv.	TMR	3617E	8	page 47
120 VDC	Opto-Isolated, Commoned, Supervised	TMR	3623/3623T	16	page 46
24 VDC	Opto-Isolated, Commoned, Supervised	TMR	3624	16	page 46
24 VDC	Supervised/Non-Supervised, Commoned	TMR	3625/3625A	32	page 46
24 VDC	Opto-Isolated, Commoned	Dual	3664	32	page 48
24 VDC	Opto-Isolated, Commoned	Dual	3674	32	page 48
Relay Output	Non-triplicated, Normally Open	Non-triplicated	3636R/3636T	32	page 43
<b>Analog Input Modules</b>					
0-5 VDC	Differential, DC Coupled	TMR	3700A	32	page 49
0-10 VDC	Differential, DC Coupled	TMR	3701	32	page 49
0-5, 0-10 VDC	Differential, Isolated	TMR	3703E	16	page 49
0-5, 0-10 VDC	High-Density, Differential, DC Coupled	TMR	3704E	64	page 49
Thermocouple	Differential, DC Coupled	TMR	3706A	32	page 52
Thermocouple	Differential, Isolated	TMR	3708E	16	page 52

## TMR Digital Output Modules

Each TMR Digital Output (DO) module receives output signals from the Main Processors on each of three channels. Each set of three signals is then voted by special quadruplicated output circuitry on the module. The circuitry produces one voted output signal and passes it to the field termination. The quadruplicated voter circuitry provides multiple redundancy for all critical signal paths, guaranteeing safety and maximum availability.

Each TMR Digital Output Module has a voltage-loopback circuit which verifies the operation of each output switch independently of the presence of a load and determines whether latent faults

exist. Failure of the detected field voltage to match the commanded state of the output point activates the LOAD/FUSE alarm indicator.

In addition, ongoing diagnostics are performed on each channel and circuit of a TMR Digital Output Module. Failure of any diagnostic on any channel activates the Fault indicator, which in turn activates the chassis alarm signal. The Fault indicator merely indicates a channel fault, *not* a module failure. The module is guaranteed to operate properly in the presence of a single fault and may continue to operate properly with certain kinds of multiple faults.

All TMR Digital Output Modules support hot-spare capability, and require a separate external termination panel (ETP) with a cable interface to the Tricon controller backplane. Each module is mechanically keyed to prevent improper installation in a configured chassis.

Digital outputs are designed to source the current to field devices, so field power must be wired to each output point on the field termination.

## 16-Point Digital Output Module Specifications

Model Number	3601E/3601T	3603B/3603E/3603T	3607E	3604E
Nominal Voltage	115 VAC	120 VDC	48 VDC	24 VDC
Type	TMR, DO	TMR, DO	TMR, DO	TMR, DO
Output Signals	16, non-commoned	16, commoned (3603E/T) 16, non-commoned (3603B)	16, non-commoned	16, non-commoned
Voltage Range	80-155 VAC	90-150 VDC	44-80 VDC	22-45 VDC
Voltage Drop <sup>a</sup>	< 3V, typical	< 1.5V, typical	< 3V, typical	< 4V, typical
Frequency Range	47-63 Hz	n/a	n/a	n/a
Current Ratings, Maximum	2A per point 12A surge/cycle	0.8A per point 4A surge/10 ms	1A per point 5A surge/10 ms	2A per point 10A surge/10 ms
Load Leakage	2 mA maximum @ 60 Hz	2 mA maximum	2 mA maximum	2 mA maximum
Chassis Leakage	4 mA maximum @ 60 Hz	n/a	n/a	n/a
Fuses (on Field Termination)	1 per output, 3A fast-acting	1 per output, 1.0A fast-acting	1 per output, 1.25A fast-acting	1 per output, 2.5A fast-acting
Point Isolation	1,500 VDC/ 2500 VDC <sup>b</sup>	1,500 VDC/ 2500 VDC <sup>c</sup>	1,500 VDC	1,500 VDC
Diagnostic Indicators				
On or Off state	1 per point	1 per point	1 per point	1 per point
Module Status	PASS, FAULT, ACTIVE	PASS, FAULT, ACTIVE	PASS, FAULT, ACTIVE	PASS, FAULT, ACTIVE
Field Alarm	LOAD/FUSE	LOAD/FUSE	LOAD/FUSE	LOAD/FUSE
Color Code	Green	Blue	Light blue	Dark blue

a. **WARNING:** The voltage drop may be significantly higher in some applications.

b. For 3601T.

c. For 3603T.

# Field Termination Options

Match your I/O module number in the first column with termination options on the right. An I/O module can be wired to a maximum of two termination panels, which may be of two different types—for example, commoned and non-commoned.

Module Model #	Module Description	Commoned Term Panels	Non-Common. Term Panels	Basic Term Panels	Nonincendive Term Panels	RG 1.180 Term Panels	Fanned-out Cables	Bypass Panels	ERT Loop-Back Cables/Panels
3501E 3501T	DI, 115 VAC/VDC, 32 pts.	9561-810F	9561-110F	9551-110F	n/a	n/a	9101-010F	n/a	9141-010F
3502E	DI, 48 VAC/VDC, 32 pts.	9562-810F	n/a	9552-610F	n/a	n/a	9101-010F	n/a	9142-010F
3503E	DI, 24 VAC/VDC, 32 pts.	9563-810F 9563-910F	n/a	9553-610F	9572-610F	n/a	9101-010F	BP9228-010F	9143-010F
3504E	DI, 24/48 VDC, non-isolated, 64 pts.	9566-810F, 24V 9565-810F, 48V	n/a	9750-310F, 24V 9750-410F, 48V	9570-610F, 24V n/a	n/a	n/a	BP9229-010F n/a	n/a
3505E	DI, 24 VDC, low threshold, 32 pts.	9563-810F 9563-910F	n/a	9553-610F	9572-610F	n/a	9101-010F	BP9228-010F	9143-010F
3510	PI, 20-20,000 Hz, 8 pts.	n/a	n/a	9753-110F	n/a	n/a	n/a	n/a	n/a
3511	PI, 20-20,000 Hz, 8 pts.	n/a	n/a	9753-110F	9793-110F	9794-110F	n/a	n/a	n/a
3515	Pulse totalizer, 24 VDC, 32 pts.	n/a	n/a	9753-110F	9572-610F	n/a	n/a	n/a	n/a
3564	DI, 24 VDC, single, 64 pts.	9566-710F	n/a	9553-610F	9571-610F	n/a	9101-010F	n/a	n/a
3601E	DO, 115 VAC, 16 pts.	9661-610F 9663-610F	9661-110F 9664-110F	9651-110F	n/a	n/a	9101-010F	n/a	9670-110F 9670-610F
3601T	DO, 115 VAC, 16 pts.	9663-610F	9664-110F	n/a	n/a	n/a	n/a	n/a	n/a
3603B	DO, 120 VDC, 16 pts.	n/a	9251-210	n/a	n/a	n/a	n/a	n/a	n/a
3603E	DO, 120 VDC, 16 pts.	9661-910F <sup>a</sup> 9664-810F <sup>a</sup>	n/a	9651-110F	n/a	n/a	9101-010F	n/a	9673-810F <sup>a</sup>
3603T	DO, 120 VDC, 16 pts.	9664-810F <sup>a</sup>	n/a	n/a	n/a	n/a	n/a	n/a	9673-810F <sup>a</sup>
3604E	DO, 24 VDC, 16 pts.	9662-810F	9662-110F	9653-610F	9671-610F	n/a	9101-010F	n/a	9671-810F
3607E	DO, 48 VDC, 16 pts.	9667-810F	9667-110F	9652-610F	n/a	n/a	9101-010F	n/a	9672-810F
3611E	DO, 115 VAC, 8 pts.	9661-510F	n/a	n/a	n/a	n/a	n/a	n/a	n/a
3613E	DO, 120 VDC, 8 pts.	9661-810F	n/a	n/a	n/a	n/a	n/a	n/a	n/a
3614E	DO, 24 VDC, 8 pts.	9662-910F	n/a	n/a	n/a	n/a	n/a	n/a	n/a
3615E	DO, 24 VDC, low power, 8 pts.	9662-710F	n/a	n/a	n/a	n/a	n/a	n/a	n/a
3617E	DO, 48 VDC, 8 pts.	9667-910F	n/a	n/a	n/a	n/a	n/a	n/a	n/a
3623	DO, 120 VDC, 16 pts.	9661-910F	n/a	9651-110F	n/a	n/a	9101-010F	n/a	n/a
3623T	DO, 120 VDC, 16 pts.	9664-810F	n/a	n/a	n/a	n/a	n/a	n/a	n/a
3624	DO, 24 VDC, self-protected, 16 pts.	9662-610F	n/a	9653-610F	9671-610F	n/a	9101-010F	n/a	n/a
3625	DO, 24 VDC, self-protected, 32 pts.	9662-610F	n/a	9653-610F	9671-610F	n/a	9101-010F	n/a	9671-810F <sup>b</sup>
3625A									
3636R 3636T	Relay output (non-triplicated), 32 pts.	n/a	9668-110F	9651-110F	n/a	n/a	9101-010F	n/a	n/a
3664	Dual DO, 24 VDC, self-protected, 32 pts.	9662-610F	n/a	9653-610F	9671-610F	n/a	9101-010F	n/a	9671-810F <sup>b</sup>