



MODCELL™ Sequence of Events Recorder

- Sequence of Events Recorder with 1 ms accuracy
- Supports up to 29 single point, individually isolated discrete inputs per unit
- Local or global time synchronization
- Common hardware platform with MODCELL process control system



MODCELL™
Multiloop Processor

FUNCTIONALITY

The Sequence of Events Recorder (SOE) is a form of MODCELL Multiloop Processor which scans up to 29 digital inputs every millisecond for state transition, with debounce filter capability. Transitions (events) are timestamped and stored in a local queue, for monitoring and logging the order in which events such as motor trips and alarms occur. The event queue will hold up to 1024 entries, and can be read via the Status Page of the Application Builder software.

The pre-configured database is contained in the Identity Module containing the controller firmware. An embedded real-time clock ensures 1 millisecond accuracy. Multiple units may be combined for greater numbers of inputs; time synchronization is accomplished over an RS-485 network using either one MODCELL as a master SOE or the OMEGA worldwide navigational system.

BASE PLATFORM

The base unit is supplied on a mounting plate which fits standard EIA racks or panels. Field terminations use groups of pluggable, screw-down termination blocks for easy signal wiring, and power supply connections are separated from field signal wiring.

The unit contains an on-board ac or dc power supply, a high-speed CPU based on a Motorola 68302 microprocessor, and associated firmware to support the discrete inputs, communications and event functions. The optional Memory Module provides redundant, removable non-volatile RAM which backs up the database and, if left on the unit during operation, current process data.

Digital inputs for the SOE identity can be isolated (2.5 to 28V dc or 4 to 16Vdc) or non-isolated with TTL power, or a combination. Communications to the Application Builder software is accomplished via the Instrument Communications Network. The event queue is read by the software and logged in the Alarm/Event Summary.

TIME SYNCHRONIZATION

The Sequence of Events firmware includes an Omega Clock Block that either monitors a timestamp signal which is broadcast every second, or transmits a timestamp signal every second. Time synchronization between multiple SOE MODCELLs is via RS-485, 2-wire communications. Up to 32 MODCELLs configured as SOE Recorders can be installed on an RS-485 network without repeaters.

If the system requires only the devices on the local network to be synchronized, one of the MODCELL Sequence of Events Recorders on the network can transmit the timestamp. An RS-485, 2-wire serial communications module is installed on each unit, with one unit acting as the Transmit master and the others set to Receive. Recommended transmission rate is 38.4K baud.

If the system requires synchronization to a global timestamp, a Kinematics/Truetime Omega Synchronized Clock Unit must be installed. This unit monitors the OMEGA navigation system which has eight transmitting stations around the world. It transmits via an RS-232 port, and an RS-232/RS-485 converter is also required. The time signal is transmitted to the MODCELL units via RS-485.

Component	Features
Processor Base Unit	<ul style="list-style-type: none"> • 5U x 19" flushmount carrier board • Powerful Motorola 68302 processor, including on-chip RISC communications processor • Universal ac power supply (85-250V ac/ 50-400 Hz) or 24V dc power supply • Embedded real-time clock with 1ms resolution
Portable Memory Module	<ul style="list-style-type: none"> • Optional plug on module that provides 64K bytes of redundant, removable non-volatile RAM for database and event queue backup, portability and integrity • Updated every 50 ms
Digital Input Modules	<ul style="list-style-type: none"> • Single-point, opto-isolated modules • Non-isolated version for TTL logic
Communications Modules	<ul style="list-style-type: none"> • High security Instrument Communication Network (ICN) for host communications • RS-485 (2-wire) serial communications for transmission of synchronization signal
Identity Module (Sequence of Events Recorder)	<ul style="list-style-type: none"> • Pre-configured database with: <ul style="list-style-type: none"> • Detection of digital transitions with 1 ms accuracy • Locally stored event queue with up to 1024 entries • OMEGA clock block for local or global time synchronization

PERFORMANCE SPECIFICATIONS - BASE UNIT

AC INPUT

Operating Range

AC option: 85-250V rms, 50-400Hz
 DC option: 20-50V dc

Peak Inrush Current

60 Amps (ac), 40 Amps (dc)

Fuse

2.5 Amps (ac), 4.0 Amps (dc)

Holdup Time

32 msec at 120V ac, 5 msec at 24V dc typical

Power Consumption (120V rms, 60Hz, Full load)

40W maximum

PERFORMANCE SPECIFICATIONS - INPUT MODULES

DC DIGITAL INPUTS (ISOLATED) - 2004AP10..	.. 100A	..110A
Input voltage ranges	2.5-28V	4-16V
Max Logic Low Input	1V	1V
Max Input current	30mA	45mA
Response time	1.5 msec	0.1 msec
Input resistance	900 ohms	300 ohms

DIGITAL INPUTS (NONISOLATED) 2006A	
Contact sense	5V/ 0.5 mA dc typical
Logic Low Input	0 to 0.65V dc or 50K ohms maximum
Logic High Input	2.2 to 24V dc or 50 ohms maximum
Max Input current	2.5 mA dc
Response time	1 msec

GENERAL SPECIFICATIONS

Operating temperature
0 to +50°C

Storage Temperature
-40 to +75°C

Humidity
5 to 95% RH, noncondensing

Data Retention (Non volatile RAM memory and Portable Memory Module)
Typically 10 years with unit unpowered

ICN Baud rate
31.25K Baud

Modbus Baud rate
9600 to 38.4K Baud

PHYSICAL SPECIFICATIONS

Height
Including mounting assembly: 8.72" (221.49 mm)

Width
19.00" (482.60 mm)

Depth
6.03" (153.16 mm)

Weight
Base Instrument with identify module: 3 lbs. 2 oz.

Mounting
Instrument mounts in 19-inch rack housing, catalog number 2001F.

DIMENSIONS

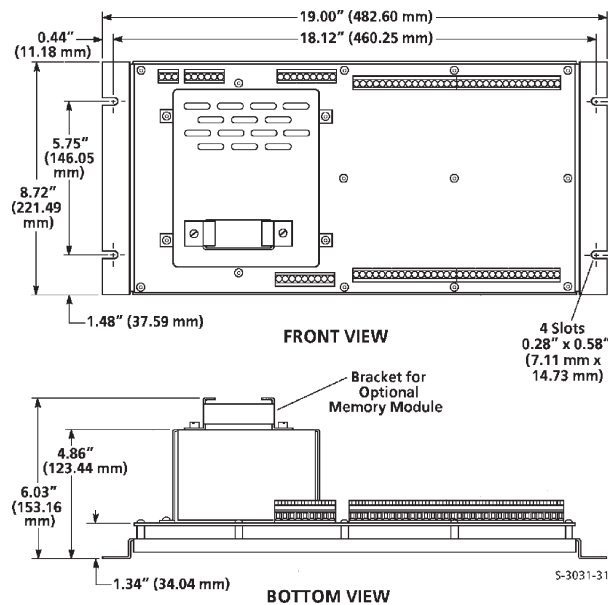

Ordering Information

1. Select base unit format and power supply requirements.
2. Select one Identity Module for each base unit.
3. Select Digital Input Modules.
4. Select Communications Modules. ICN module required for communication to PC-30 Software; RS-485 module required for transmission of time synchronization signal between multiple units.

1. Base Instrument

AC power: 85 - 250V rms, 50-400Hz	2002NZ10801C
AC power: 85 - 250V rms, 50-400Hz (EU EMC Compliant - See IB-23C600 for restrictions)	2002NZ12801C
DC power: 20 - 50V dc	2002NZ10401C

2. Identity Module

Sequence of Events Recorder	2005PZ10102C
-----------------------------------	--------------

3. Accessories

MODCELL Multiloop User's Guide - complete documentation (included with 2006S)	98280-417
ICN Termination Assembly - Eurocard format (1 per ICN network).....	2030FZ00001A
ICN Termination Assembly - Flushmount format (1per ICN network)	2030FZ00002A
Portable Memory Module (optional)	2010PZ10000A

4. Digital Input Modules

Slots Power

Digital Input - Isolated

2.5 to 28V dc	1	12mA	2004AP10100A
4 to 16V dc	1	12mA	2004AP10110A

Digital Input - Nonisolated

2.2V to 24V dc (contains internal 5V supply for direct hardwire connection)	1	10mA	2006AZ10100A
---	---	------------	--------------

5. Communications Modules

Instrument Communications Network (ICN)*	2	300mA	2030NZ10000B
Serial Communications for Time Synchronization			
RS-485, 2-wire	1	180mA	2032NZ10000C

6. Configuration Software (consult Factory)

Application Builder software - allows reading of queue from status page

www.micromodautomation.com

The Company's policy is one of continuous product improvement and the right is reserved to modify the information contained herein without notice.

Printed in USA (05.5.04)

© MicroMod Automation, Inc. 2004



MicroMod Automation, Inc.
 75 Town Centre Dr.
 Rochester, NY 14623 USA
 Tel: (585) 321-9200
 Fax: (585) 321-9202
 Email: sales@micmod.com

S-MOD-SOE_1