

Advant Controller 31 Intelligent Decentralized Automation System

Basic Unit 07 KT 98

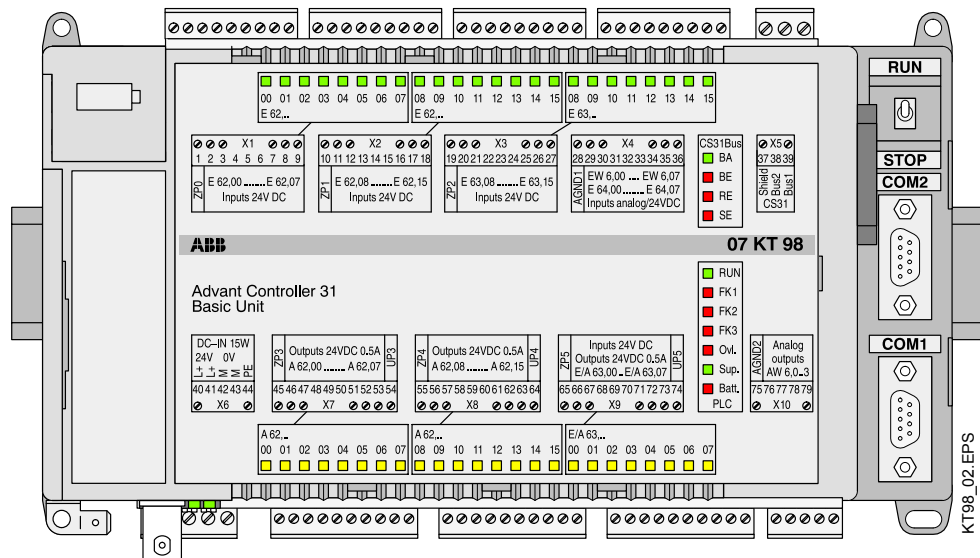

2.2 Basic Unit 07 KT 98

Basic unit with max. 1 MB user program

+ 1 MB user data + 256 kB RETAIN, CS31 system bus

The basic unit 07 KT 98 is offered with several networking possibilities. A table on page 2.2-3 shows the features of the different basic units.

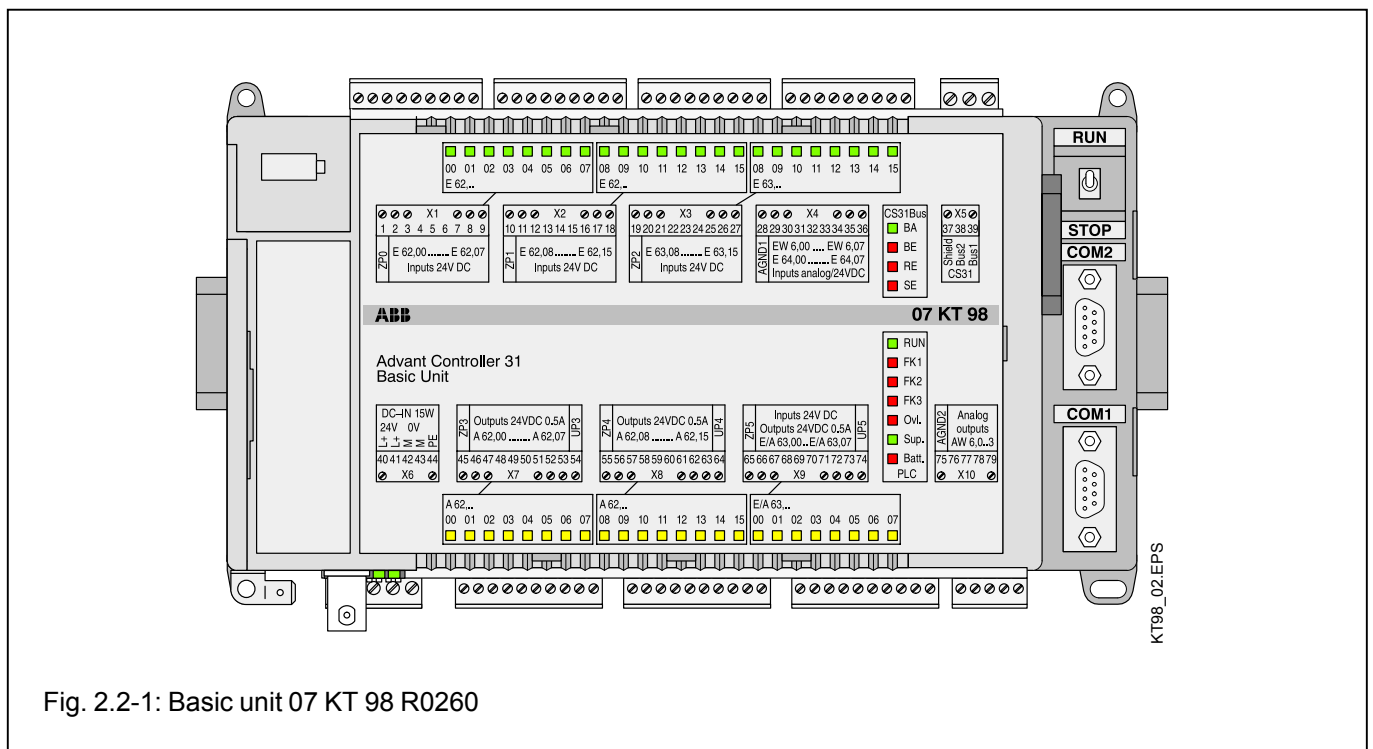

Fig. 2.2-1: Basic unit 07 KT 98 R0260

Contents

2.2.1	Brief description	page 2.2-4
2.2.1.1	Main features	4
2.2.1.2	Project planning / Start-up	4
2.2.2	Front view	5
2.2.3	Structure of the front panel	6
2.2.3.1	Terminal assignment overview	7
2.2.4	Electrical connection	8
2.2.4.1	Application example for input and output wiring	8
2.2.4.2	Connection of the supply voltage	9
2.2.4.3	Connection of the CS31 system bus	9
2.2.4.4	Connection of the digital inputs	10
2.2.4.5	Connection of the digital outputs	11
2.2.4.6	Connection of the digital inputs/outputs	12
2.2.4.7	Connection of the 8 configurable analog inputs	13
2.2.4.8	Connection of the 4 configurable analog outputs	20
2.2.4.9	Battery and battery replacement	21
2.2.4.10	Serial interface COM1	21
2.2.4.11	Serial interface COM2	22
2.2.4.12	Networking interface	22
2.2.5	SmartMedia Card	23

2.2.6	High-speed counter	page 2.2-24
2.2.7	Technical data 07 KT 98	25
2.2.7.1	General data	25
2.2.7.2	Power supply	25
2.2.7.3	Lithium battery	26
2.2.7.4	Digital inputs	26
2.2.7.5	Digital outputs	26
2.2.7.6	Digital inputs/outputs	27
2.2.7.7	Analog inputs	27
2.2.7.8	Analog outputs	28
2.2.7.9	Connection of the serial interfaces COM1 and COM2	29
2.2.7.10	Connection of the CS31 system bus	29
2.2.7.12	LED displays	30
2.2.7.13	High-speed hardware counter	30
2.2.7.14	Mechanical data	31
2.2.7.15	Mounting hints	31
2.2.7.16	Ordering data	32
2.2.11	ARCNET	33
2.2.12	PROFIBUS-DP	37
2.2.13	CANopen	40
2.2.14	Ethernet	43

Functionality of the basic unit 07 KT 98

User program	1 MB
User data	1 MB + 256 kB RETAIN + 128 kB (Flash EPROM)
Digital inputs	24 in 3 groups of 8 each, electrically isolated
Digital outputs	16 transistor outputs in 2 groups of 8 each, electrically isolated
Digital inputs/outputs	8 in 1 group, electrically isolated
Analog inputs	8 in 1 group, individually configurable to 0...10 V, 0...5 V, +10 V, +5 V, 0...20 mA, 4...20 mA, Pt100 (2-wire or 3-wire), differential inputs, digital inputs
Analog outputs	4 in 1 group, individually configurable to 0...10 V, 0...20 mA, 4...20 mA
Serial interfaces	COM1, COM 2 as MODBUS interfaces, for programming and test functions and as freely programmable interfaces
Parallel interfaces for connection of couplers	07 KP 90 (RCOM), 07 KP 93 (2 x MODBUS), 07 MK 92 (freely programmable)
System bus interface	CS31
Integrated couplers	see next page
High-speed counter	integrated, many functions configurable
Real-time clock	integrated
SmartMedia Card	memory medium for operating system, user program and user data
LED displays	for signal conditions, operating statuses and error messages
Power supply voltage	24 V DC
Data backup	with lithium battery 07 LE 90
Programming software	907 AC 1131 as of V 4.1 (07 KT 98 with ARCNET interface) 907 AC 1131 as of V 4.2.1 (07 KT 98 with PROFIBUS-DP interface)

Differences between the basic units 07 KT 95 to 07 KT 98

Basic unit	07 KT 95	07 KT 96	07 KT 97	07 KT 98		
Number of digital inputs	12	24	24	24		
Number of digital outputs	8	16	16	16		
No. of digital inputs/outputs	-	-	8	8		
Number of analog inputs	4	-	8	8		
Pt100	no	-	yes	yes		
Number of analog outputs	2	-	4	4		
20 mA	no	-	yes	yes		
Are the analog inputs configurable as digital inputs?	no	-	yes	yes		
Terminals 20 to 27	- - -	E 63,00 to E 63,07	E 63,08 to E 63,15	E 63,08 to E 63,15		
Processing time, 65 % bits, 35 % words, for 1 kB of program, typ.	0.3 ms	0.3 ms	0.3 ms	0.07 ms		
Order number	GJR5 2528 00 R....	GJR5 2529 00 R....	GJR5 2530 00 R....	GJR5 2531 00 R....		

Available versions of the basic units 07 KT 95 to 07 KT 98

Version of the basic unit	Integrated (internal) couplers	Version is available with			
		07 KT 95	07 KT 96	07 KT 97	07 KT 98
R0100, R0200	none	◆	◆	◆	
R0120, R0220	PROFIBUS-DP			◆	◆
R0160, R0260	ARCNET			◆	◆
R0162, R0262	ARCNET + PROFIBUS-DP			◆	◆
R0268	ARCNET + CANopen				◆
R0270	Ethernet			◆	◆
R0272	Ethernet + PROFIBUS-DP			◆	◆
R0276	Ethernet + ARCNET			◆	◆
R0277	Ethernet + Ethernet			◆	◆
R0278	Ethernet + CANopen			◆	◆
R0280	CANopen			◆	◆

Usable SmartMedia Cards

Version of the basic unit	Usable SmartMedia Card	
	07 MC 90, 5 V GJR5 2526 00 R0101	07 MC 90, 3.3 V GJR5 2526 00 R0201
R0100 to R0199	◆	
R0200 to R0299	◆	◆

2.2.1 Brief description

The basic unit 07 KT 98 works either as

- bus master in the decentralized automation system Advant Controller 31 or as
- slave (remote processor) in the decentralized automation system Advant Controller 31 or as
- stand-alone basic unit.

The basic unit is powered by 24 V DC.

2.2.1.1 Main features

- 24 digital inputs with LED displays
- 16 digital transistor outputs with LED displays
- 8 digital inputs/outputs with LED displays
- 8 **individually configurable** analog inputs 0...10 V, 0...5 V, ± 10 V, ± 5 V, 0...20 mA, 4...20 mA, differential inputs, Pt100 (2-wire or 3-wire), the analog inputs are also individually configurable as digital inputs
- 4 **individually configurable** analog outputs ± 10 V, 0...20 mA, 4...20 mA
- 2 counters for counting frequencies up to 50 kHz, configurable in 7 different operating modes
- 1 CS31 system bus interface for system expansion
- 1 interface for connecting communication modules (e.g. 07 KP 90)
- 2 serial interfaces COM1, COM2
 - as MODBUS interfaces and
 - for programming and test functions
 - as freely programmable interfaces
- Real-time clock
- LEDs for displaying operating conditions and error messages
- Detachable screw-type terminal blocks
- Fastening by screws or by snapping the device onto a DIN rail
- The lithium battery 07 LE 90 can be put into the battery compartment in order to
 - store and backup data which is additionally contained in the RAM, e.g. the status of flags (RETAIN)
 - backup the time and date (real-time clock)
- RUN/STOP switch for starting and aborting the program execution
- Extensive diagnosis functions
 - self-diagnosis of the basic unit
 - diagnosis of the CS31 system bus and the connected modules

- Integrated Flash EPROM for storing program and data
- Exchangeable SmartMedia Card 07 MC 90 for user data or for updating the operating system or PLC program

2.2.1.2 Project planning / start-up

The following has to be observed for project planning and start-up:

- Programming is performed with AC31 programming software, which can be run on commercially available IBM compatible PCs (see documentation of the programming system 907 AC 1131).
- Online program modification
A quick modification of the user program is possible without interrupting the operation (see programming system 907 AC 1131).
- Possible operating modes
 - Stand-alone basic unit
 - Bus master basic unit
 - Slave basic unit
- Backup of data areas, i.e. saving of data during power OFF/ON, is possible with an integrated battery and/or by storing them in the Flash EPROM.
- When using the PROFIBUS DP interface, project planning is performed in the same way as with 07 KT 97. For details see chapter "System Description".

2.2.2 Front view

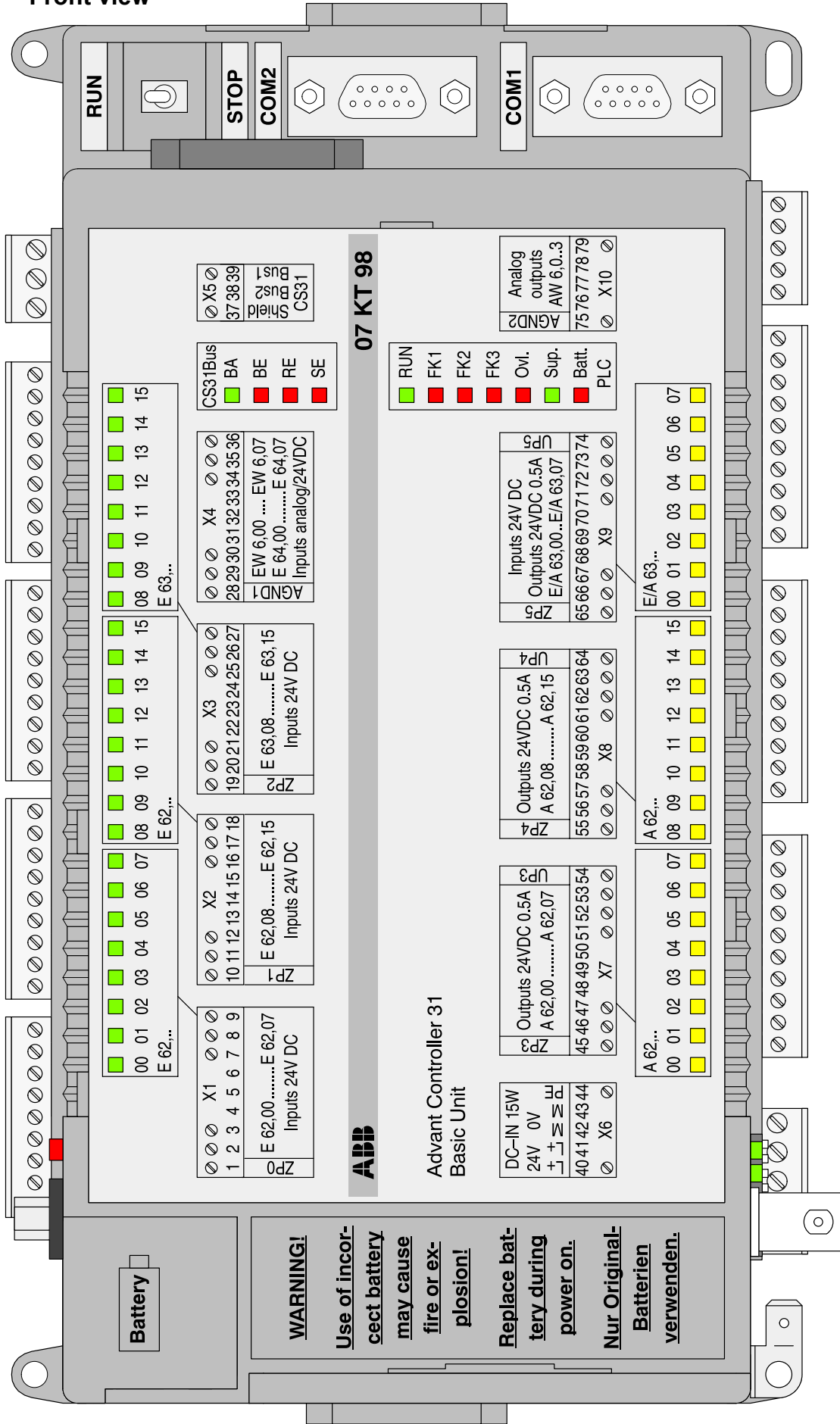

KT98_05A.EPS

Fig. 2.2-2: Front view 07 KT 98 R262

2.2.3 Structure of the front panel

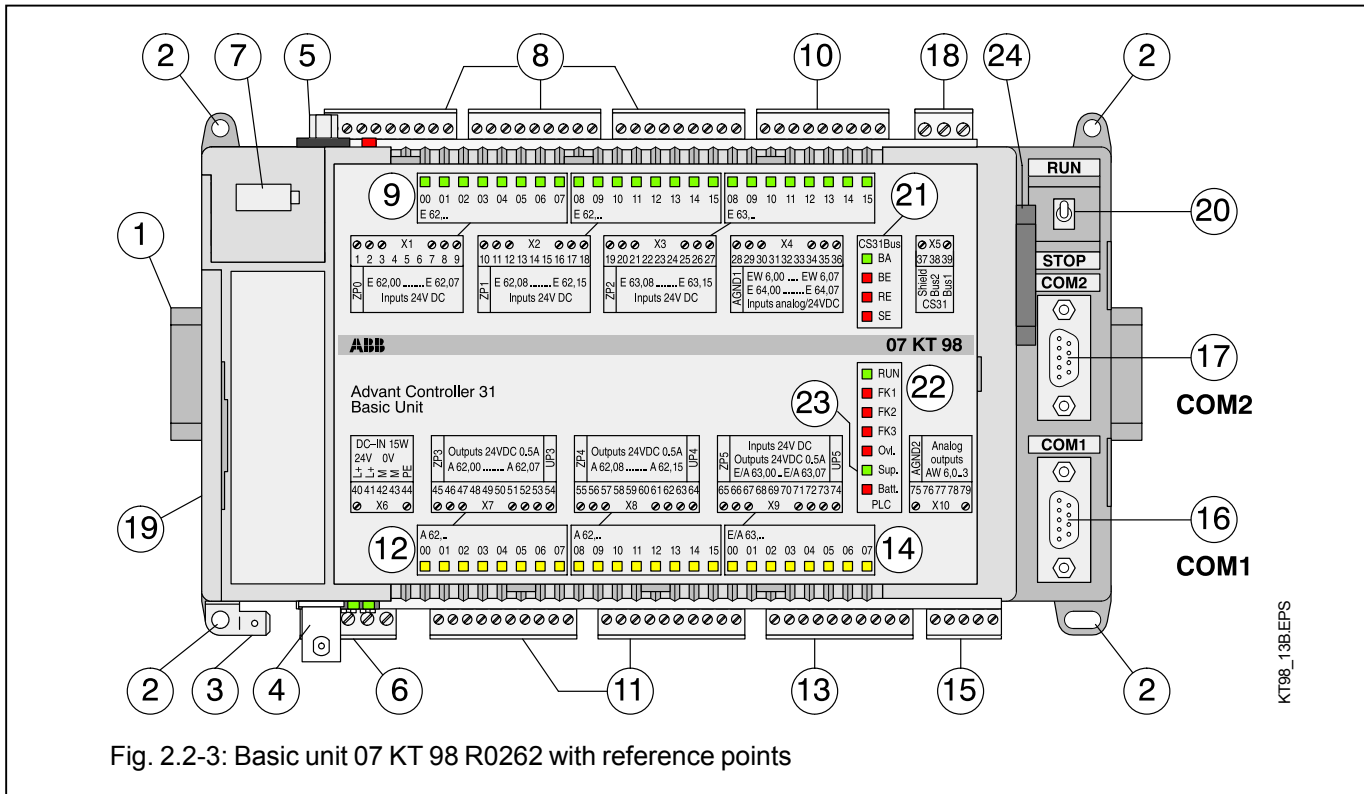

Fig. 2.2-3: Basic unit 07 KT 98 R0262 with reference points

- | | |
|---|---|
| <p>(1) Fastening the device on DIN rail</p> <p>(2) Fastening the device by screws</p> <p>(3) Faston earthing terminal 6.3 mm</p> <p>(4) ARCNET interface (BNC connector)</p> <p>(5) PROFIBUS-DP interface (SUB-D, 9-pole)</p> <p>(6) Supply voltage connection 24 V DC</p> <p>(7) Battery compartment</p> <p>(8) 24 digital inputs in 3 groups</p> <p>(9) 24 green LEDs for the digital inputs</p> <p>(10) 8 individually configurable analog inputs in one group 0...10 V, 0...5 V, ± 10 V, ± 5 V, 0...20 mA, 4...20 mA, Pt100 (2-wire or 3-wire), differential inputs, the analog inputs are also individually configurable as digital inputs</p> <p>(11) 16 digital transistor outputs in two groups</p> <p>(12) 16 yellow LEDs for the digital outputs</p> <p>(13) 8 digital inputs/outputs in one group</p> <p>(14) 8 yellow LEDs for the digital inputs/outputs</p> <p>(15) 4 individually configurable analog outputs ± 10 V, 0...20 mA, 4...20 mA in one group</p> <p>(16) Serial interface COM1 (programming, MMC)</p> <p>(17) Serial interface COM2 (programming, MMC)</p> | <p>(18) Connection for CS31 system bus</p> <p>(19) Cover of the interface for the connection of communication modules (may only be removed for connecting communication modules)</p> <p>(20) Switch for RUN/STOP operation: With the RUN/STOP switch the execution of the user program is started or stopped.</p> <p>(21) LED displays for CS31 system bus
 BA LED green Bus active
 BE LED red Bus error
 RE LED red Remote unit error
 SE LED red Serial unit error</p> <p>(22) LED displays for RUN and error class
 RUN LED green User progr. is running
 FK1 LED red Fatal error
 FK2 LED red Serious error
 FK3 LED red Light error</p> <p>(23) Other LED displays
 Over- LED red Overload/short-circuit at an output
 load
 Supply LED green Supply voltage available
 Battery LED red Batt. not effective</p> <p>(24) Insertable SmartMedia Card 07 MC 90 for operating system, user program and user data</p> |
|---|---|

2.2.3.1 Terminal assignment overview

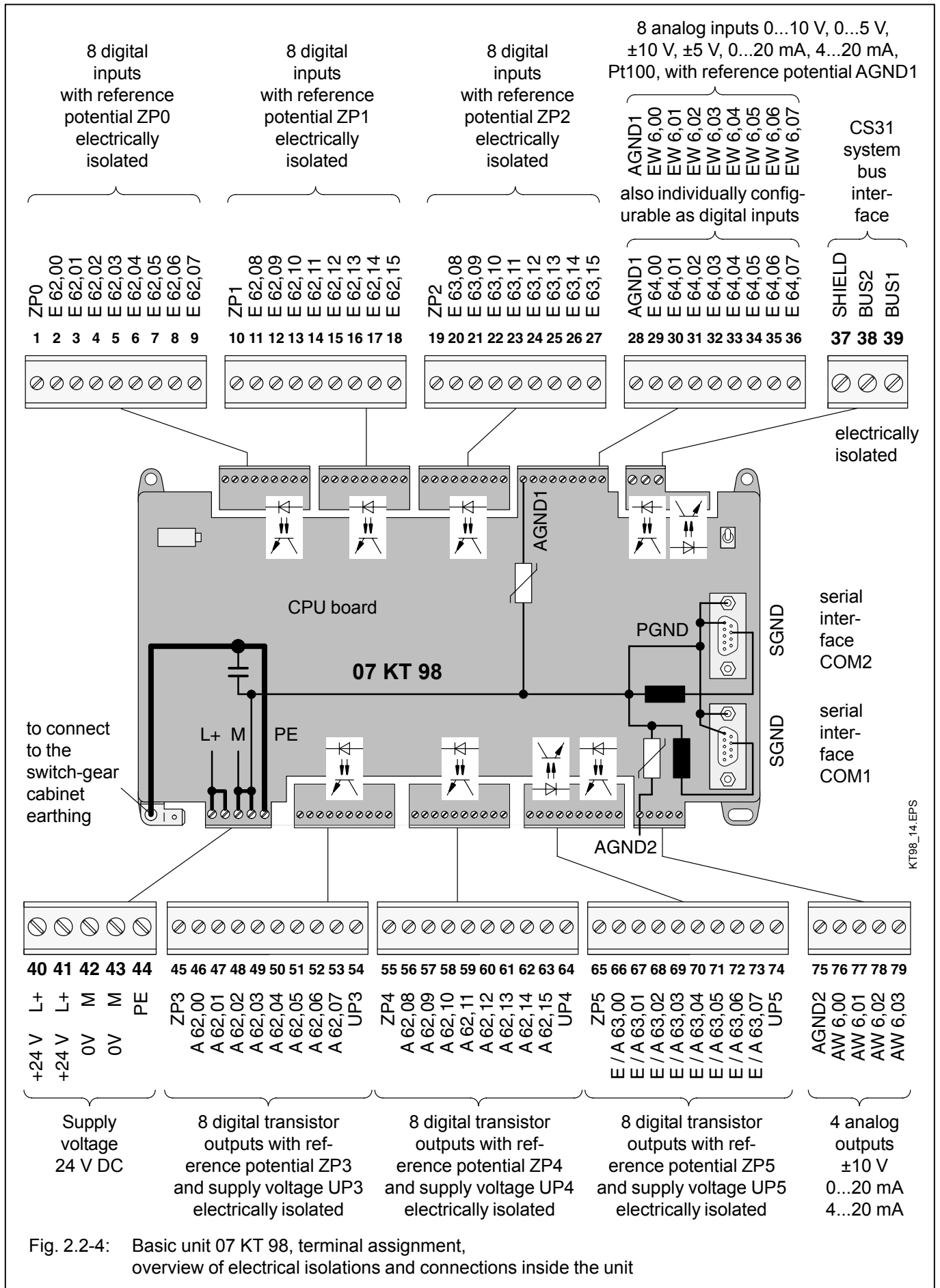

Fig. 2.2-4: Basic unit 07 KT 98, terminal assignment, overview of electrical isolations and connections inside the unit

2.2.4 Electrical connection

2.2.4.1 Application example for input and output wiring

The following illustration shows an application example in which different possibilities for wiring inputs and outputs are used.

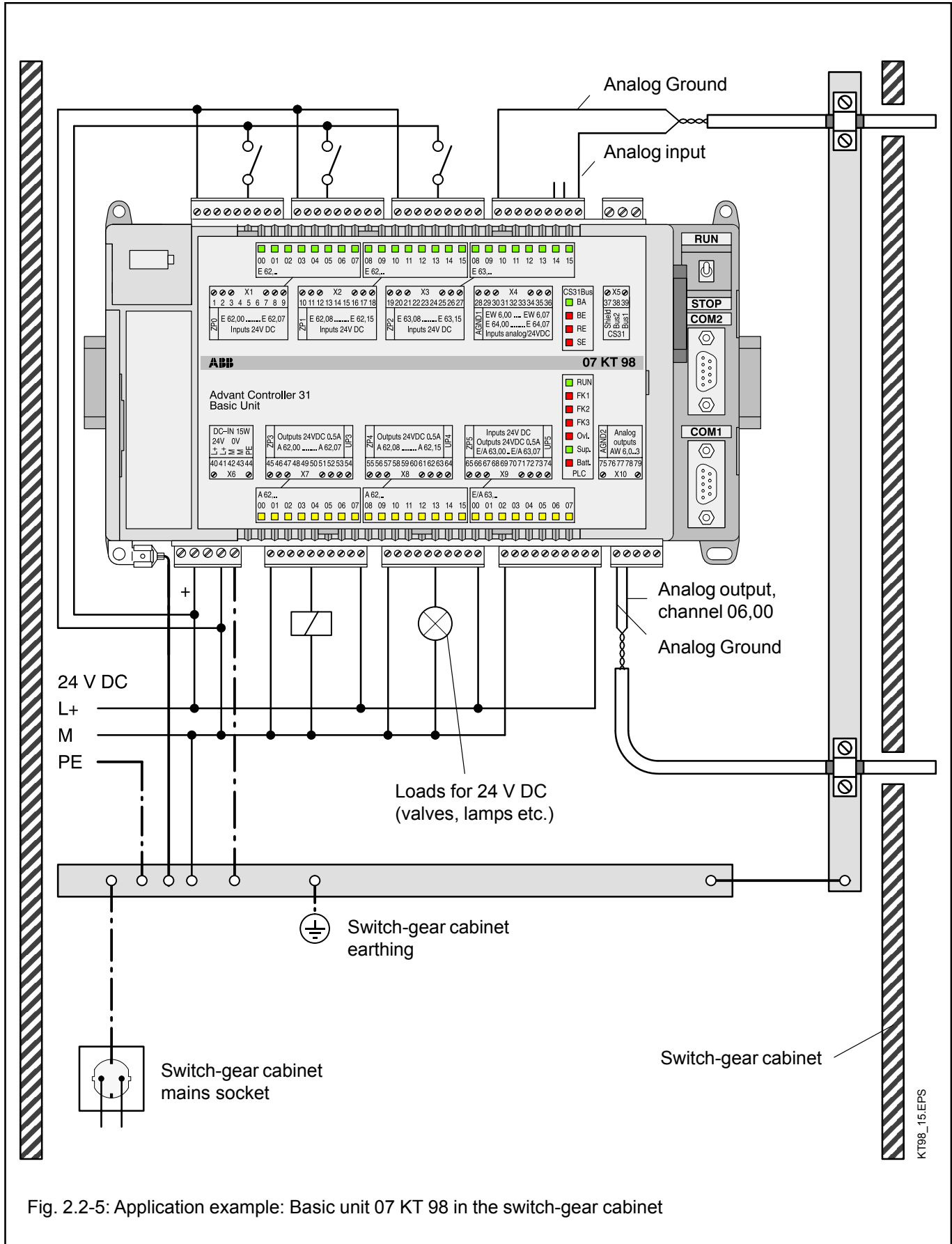

Fig. 2.2-5: Application example: Basic unit 07 KT 98 in the switch-gear cabinet

Please observe in particular:

- The earthing measures
- The handling of the electrically isolated input groups
- The handling of the electrically isolated output groups
- The connection of shielded analog cables
- The earthing of the switch-gear cabinet mains socket

2.2.4.2 Connection of the supply voltage

The 24 V DC supply voltage is connected via a 5-pole detachable screw-type terminal block.

Attention: Plug and unplug terminal block only with power is off!

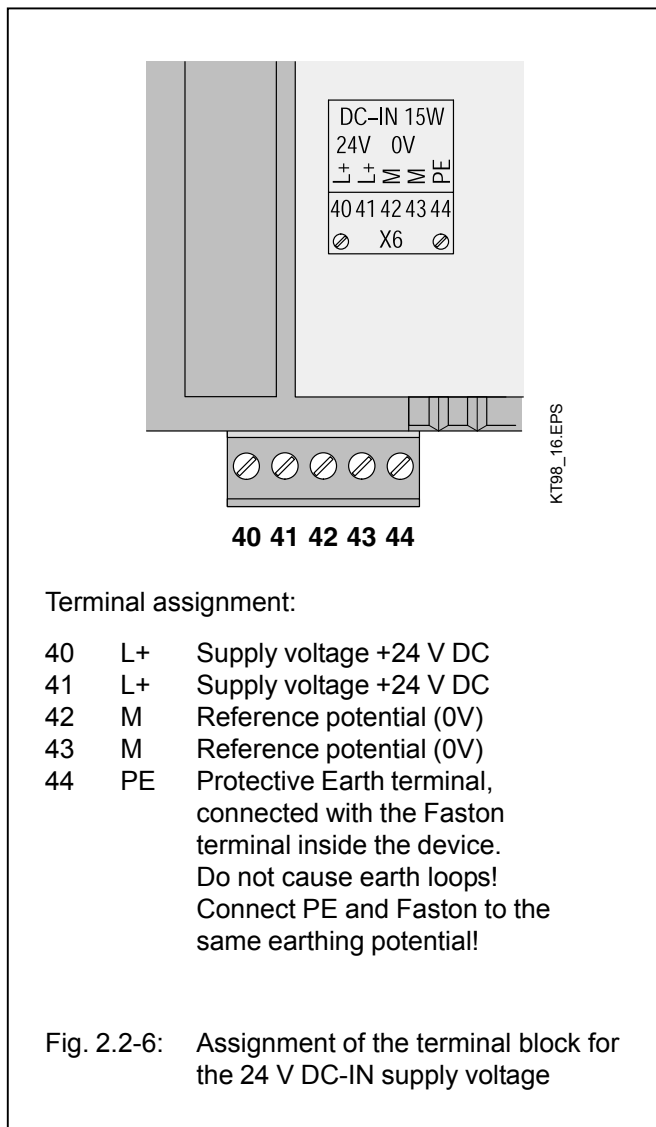

The terminals 40 and 41 (L+) as well as 42 and 43 (M) are connected to each other via the printed circuit board. If the power supply is looped through, these two connections must not be burdened with currents higher than **4 A**.

Please take also into consideration that supply voltages which are looped through are disconnected for the following devices when the plug is withdrawn.

If higher currents are to be conducted without interruption possibility, the two wires for M have to be connected under the same terminal. The same applies for L+.

2.2.4.3 Connection for the CS31 system bus

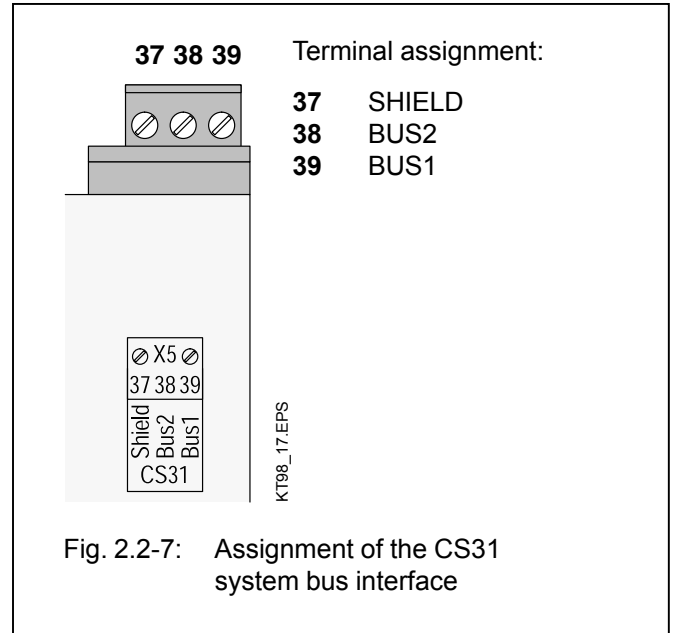

The connection to the CS31 system bus is made by means of a 3-pole detachable terminal block. Please observe:

- All of the AC31 devices, no matter whether they are master or slave devices, are connected with twisted-pair bus line as follows:
 - One core of the bus line is looped through via the BUS1 terminals of all devices to be connected to the CS31 system bus.
 - The other core of the bus line is looped through via the BUS2 terminals of all devices to be connected to the CS31 system bus.
- If the basic unit 07 KT 98 is located at the beginning or at the end of the bus line, the bus terminating resistor (120 Ω) has to be connected additionally between the BUS1 and BUS2 terminals.
- The shield of the twisted-pair bus line is looped through via the SHIELD terminals of all the devices to be connected to the CS31 system bus.
- The handling of the CS31 system bus is described in detail in volume 2, System data.

2.2.4.4 Connection of the digital inputs

The following figure shows the assignment of the 24 digital inputs.

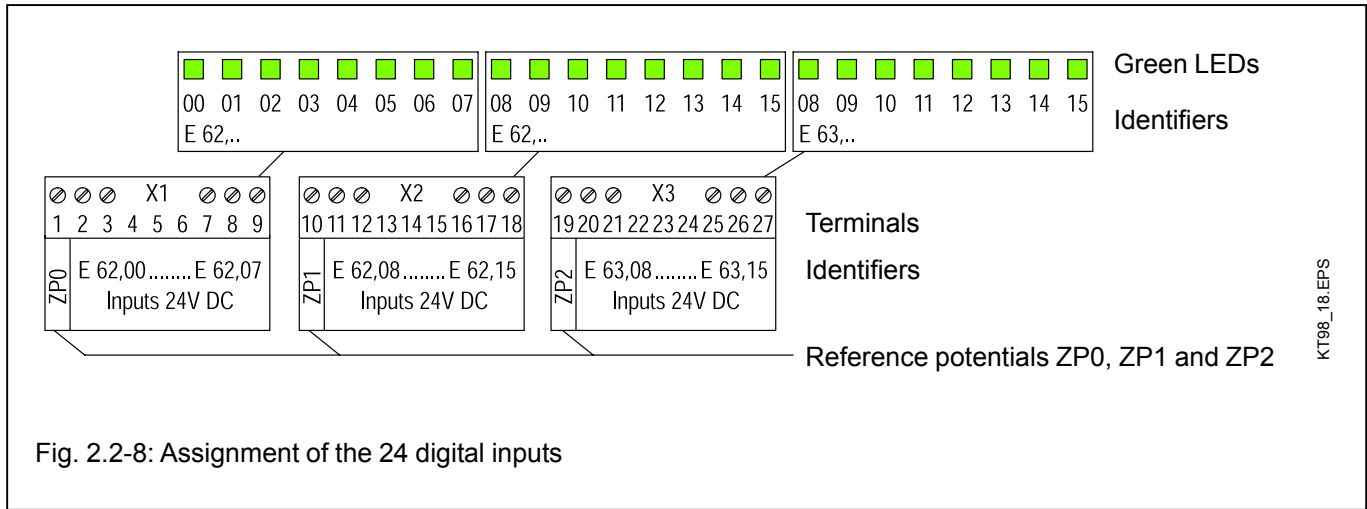

Features:

- The 24 digital inputs are arranged in three groups of 8 inputs each.
- The three groups E 62,00...E 62,07, E 62,08...E 62,15 and E 63,08...E 63,15 are electrically isolated from each other.
- The inputs use 24V signals in positive logic (1 = +24 V).
- The signal delay of the inputs is configurable to 7 ms (default) or 1 ms (see "System technology").
- The circuit configuration of the first group of the digital inputs is shown as an example in the following.

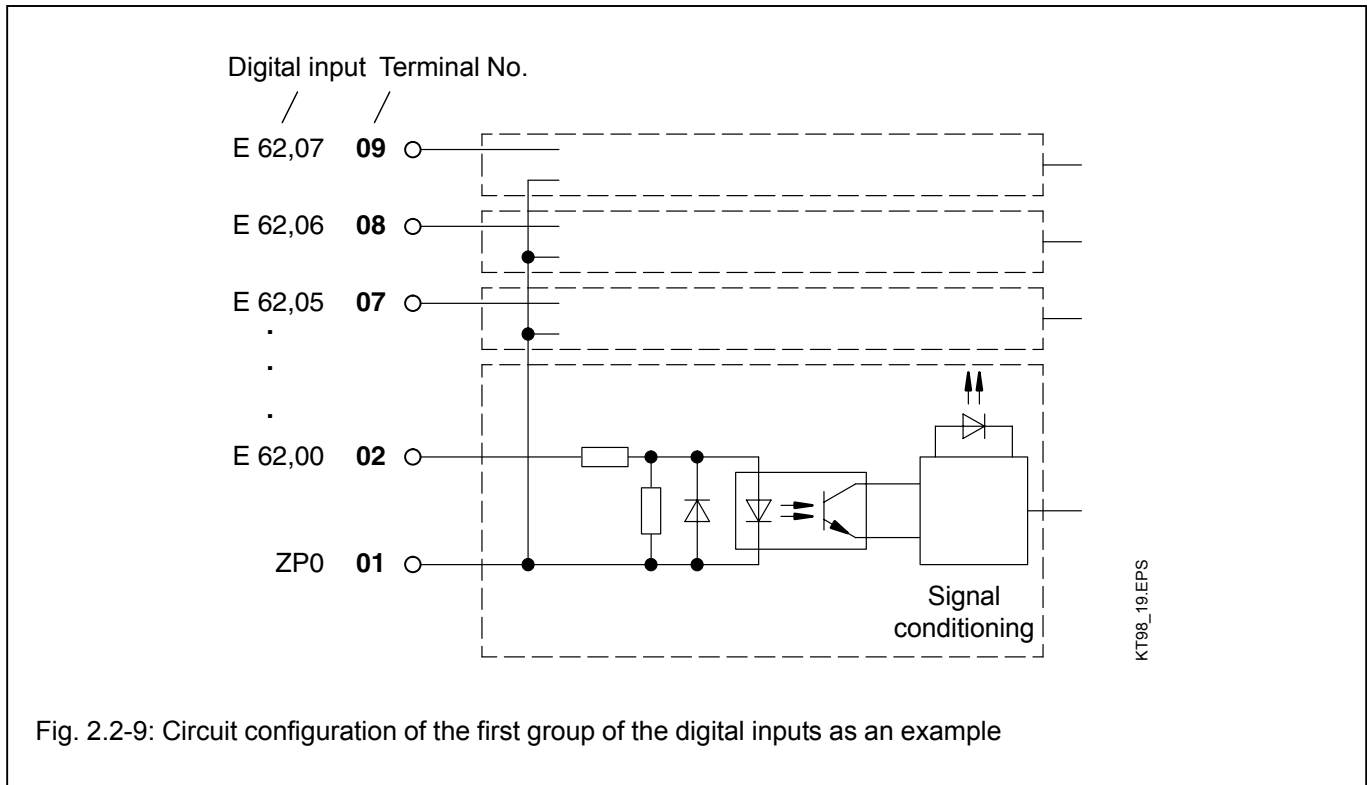

2.2.4.5 Connection of the digital outputs

The following figure shows the assignment of the 16 digital outputs.

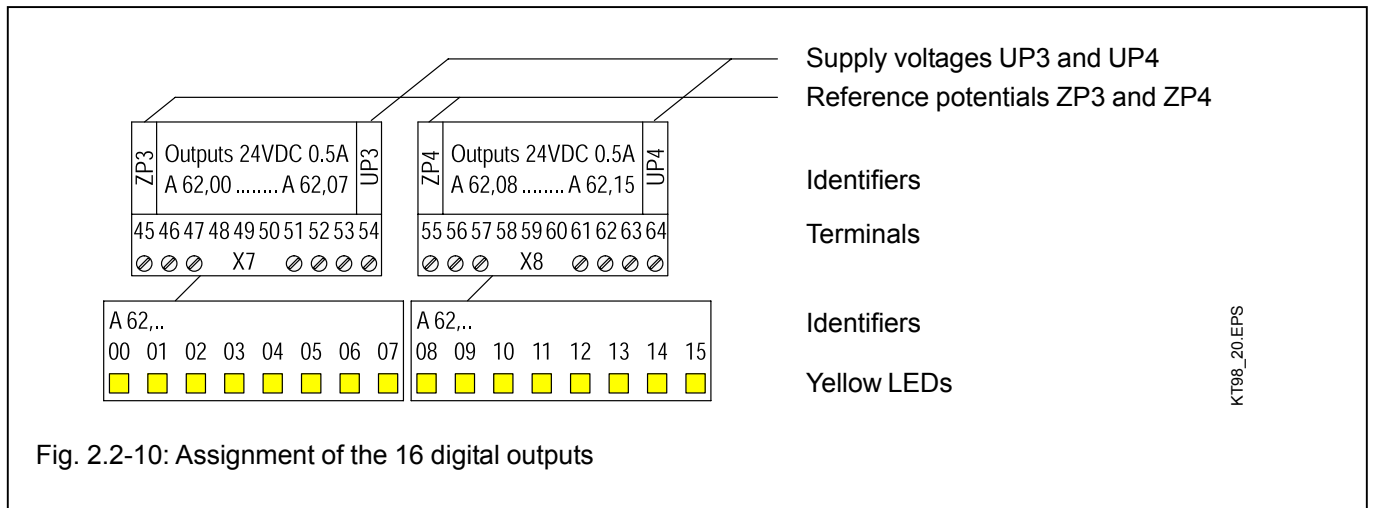

Features of the digital outputs:

- The 16 digital outputs are arranged in two groups of 8 outputs each.
- The two groups are electrically isolated from each other.
- The outputs can be loaded with a rated current of 500 mA.
- Each group as a whole is electrically isolated from the rest of the device.
- The outputs employ semiconductors and are short-circuit and overload-proof.
- The outputs are automatically switched off in case of overload or short-circuit.
- An overall error message indicates whether a short-circuit or an overload has occurred on a output group.
- The overload is displayed by the red LED Ovl. and via error flags in the PLC.
- The red LED Ovl. goes out when the overloaded output is switched on again automatically.
- The outputs are safe against reverse polarity and forced supply of 24 V DC.

Circuit configuration of the digital outputs

The following figure shows the circuit configuration of the digital outputs of the first group as an example.

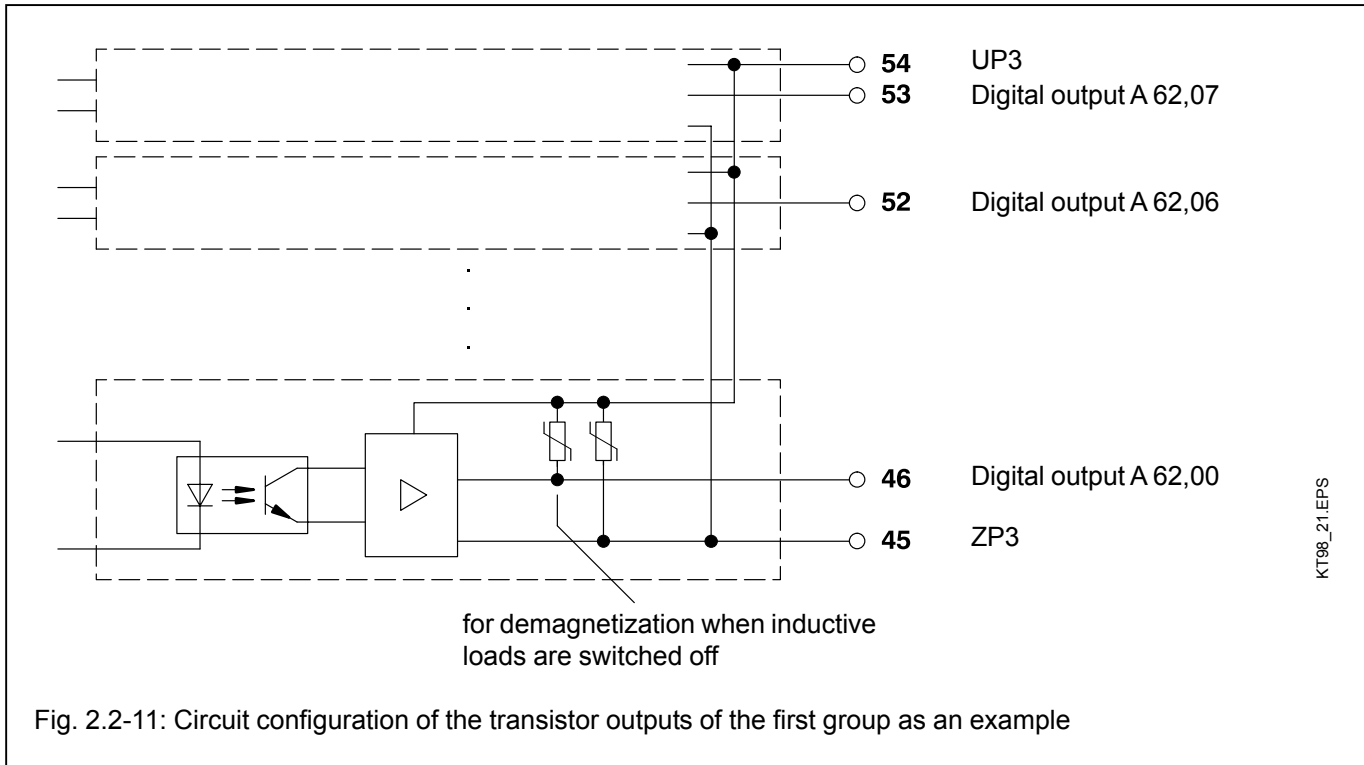

Fig. 2.2-11: Circuit configuration of the transistor outputs of the first group as an example

2.2.4.6 Connection of the digital inputs/outputs

The following figure shows the assignment of the 8 digital inputs/outputs.

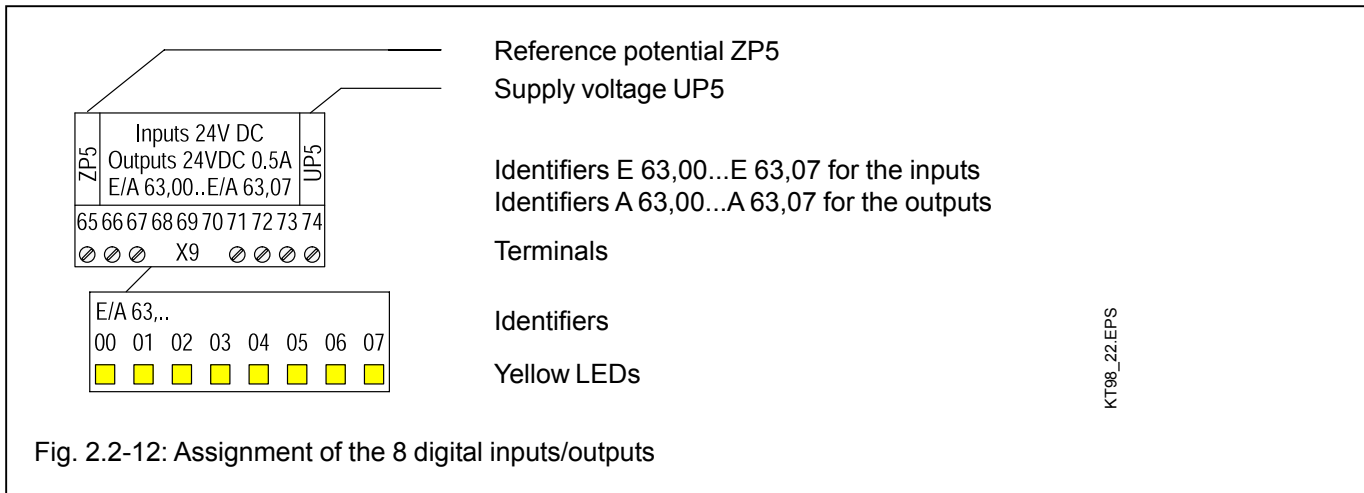

Fig. 2.2-12: Assignment of the 8 digital inputs/outputs

Features of the digital inputs/outputs:

- The 8 digital inputs/outputs are arranged in one group.
- The group as a whole is electrically isolated from the rest of the device.
- The inputs/outputs can be used individually as input, output or re-readable output.
- If the terminals are used as digital inputs, the input signal delay can be configured to 7 ms (default) or to 1 ms (see "System technology").
- If the terminals are used as digital outputs, the output signals "1" are individually monitored by the re-readable input. If the output status is wrong, an overall error message is generated for the involved output group. The error is displayed by the red LED Ovl. and by error flags of the PLC then. The error could have been caused by overload, short-circuit or missing supply voltage UP5/ZP5. The technical specifications of the outputs are the same as with the other digital outputs.

Circuit configuration of the digital inputs/outputs

The following figure shows one of the 8 inputs/outputs of the group as an example.

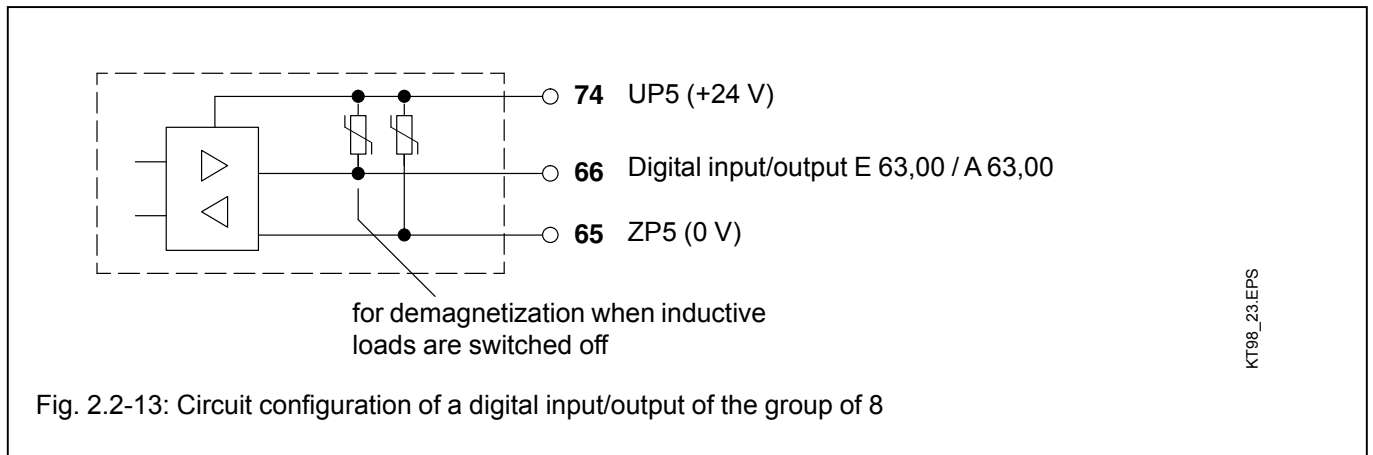

Fig. 2.2-13: Circuit configuration of a digital input/output of the group of 8

- The technical specifications of the inputs are the same with the other digital inputs, but **with the following exception:**

Caused by the direct electrical connection with the output, the varistor for demagnetization of inductive loads (see figure above) is also in effect at the input.

Therefore, the voltage difference between UP5 and the input signal must not be greater than the limit voltage of the varistor.

The limit voltage of the varistor is ca. 36 V. This means, that if UP5 = 24 V, the input signal voltage must be between -12 V and +30 V. If UP5 = 30 V, the input voltage has to be within -6 V and +30 V.

If all of the 8 channels of the group are used as inputs, and if in addition the UP5 terminal is left unconnected, no restrictions exist for the inputs. The input signal voltages then may be within -30 V and +30 V.

There is no restriction for the input/output group concerning its safety against reversed polarity.

2.2.4.7 Connection of the 8 configurable analog inputs

The following figure shows the assignment of the 8 analog inputs.

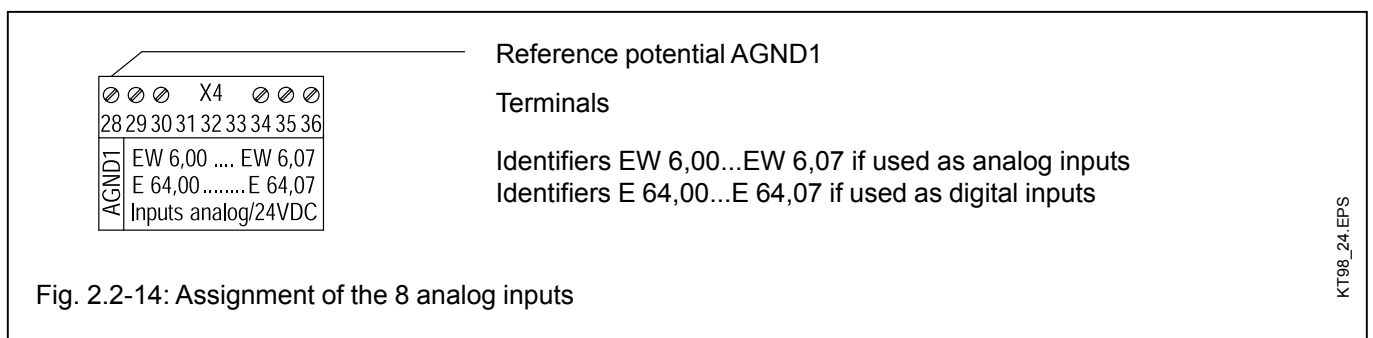

Fig. 2.2-14: Assignment of the 8 analog inputs

Features of the analog inputs:

- The 8 analog inputs are **not** electrically isolated.
- Resolution in the PLC system: The measured values are converted with a resolution of 12 bits, i.e. 11 bits plus sign for voltage and 12 bits without sign for currents. The ranges 0...5 V and ± 5 V are converted with 10 bits plus sign.
- Analog signals are conducted in shielded cables (see Fig. 2.2-5).

- The analog inputs can be used individually in a lot of different operating modes (even as digital inputs). The operating modes are configurable.
- In order to make sure, that unused input channels have a defined 0V level, they may be shorted to AGND.

In the following, some application examples are shown for analog sensors.

Measuring ranges $\pm 10\text{ V}$ / $\pm 5\text{ V}$ / $0\dots 10\text{ V}$ / $0\dots 5\text{ V}$

Input voltages which exceed the measuring range cause an overflow error message. If the measured value is below the range, an underflow error message is generated.

The input impedance is $> 100\text{ k}\Omega$.

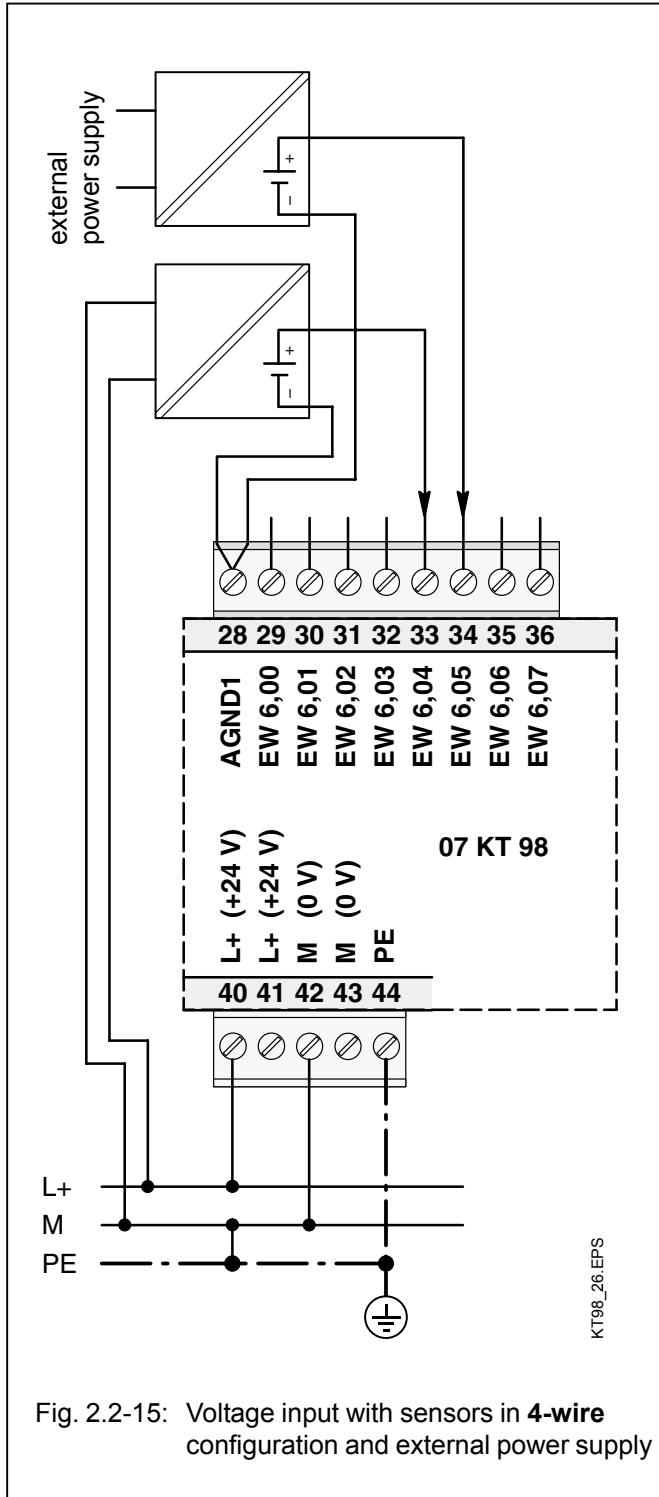

Fig. 2.2-15: Voltage input with sensors in **4-wire** configuration and external power supply

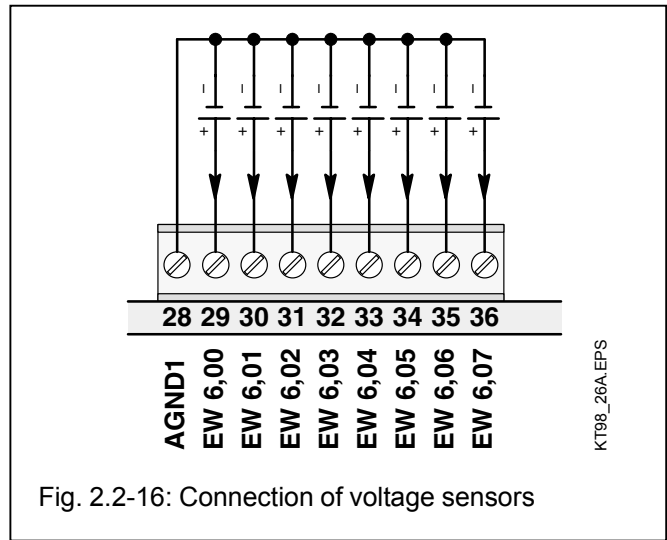

Fig. 2.2-16: Connection of voltage sensors

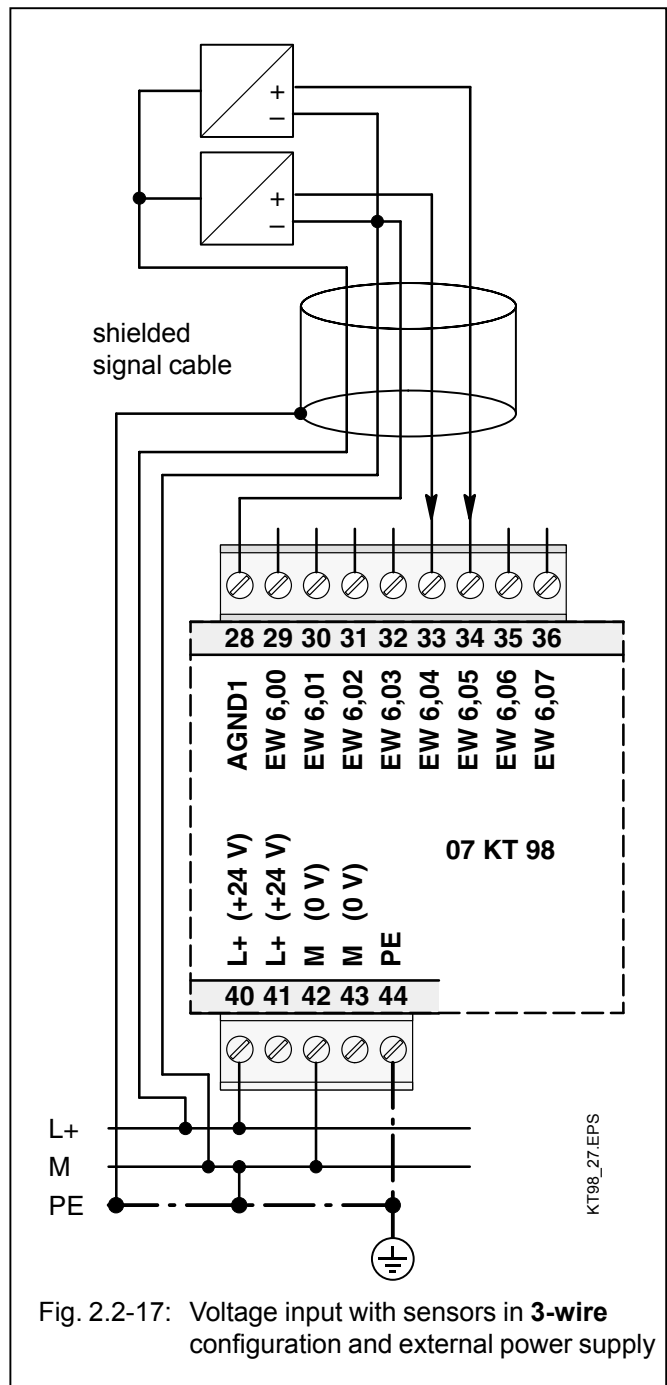

Fig. 2.2-17: Voltage input with sensors in **3-wire** configuration and external power supply

Measuring range 4...20 mA (passive-type 2-pole sensors)

Input currents which exceed the measuring range cause an overflow error message. If the measured value is below the range, an underflow error message is generated.

The input impedance is ca. 330 Ω. The current input has a self-protecting mechanism. If the input current gets too high, the shunt is switched off and the value for range overflow is generated. About every second, the unit tries to switch on the shunt again. In this way the correct measurement will succeed after the current has reached a normal value again.

The trigger of the self-protecting mechanism is displayed by the red LED Ovl. as long as the overload is present. In the PLC system an error message is then stored (FK4, error number 4).

The open-circuit monitoring begins below ca. 3 mA. The value of the range underflow is stored. If the open-circuit monitoring is configured, the open-circuit event is displayed by the red LED Ovl. as long as it is present. In the PLC system an error message is stored (FK4, error number 9).

The following figure shows the connection of **2-pole passive-type** analog sensors 4...20 mA.

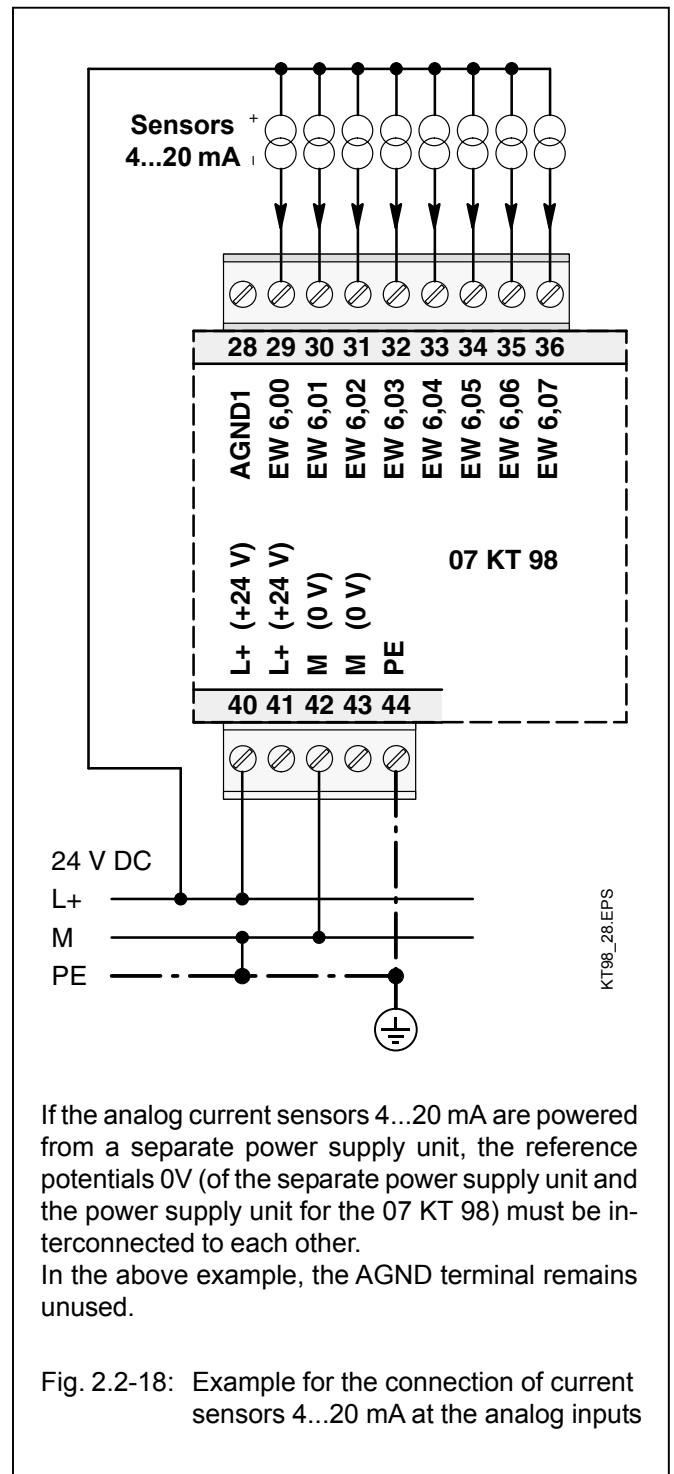

If the analog current sensors 4...20 mA are powered from a separate power supply unit, the reference potentials 0V (of the separate power supply unit and the power supply unit for the 07 KT 98) must be interconnected to each other. In the above example, the AGND terminal remains unused.

Fig. 2.2-18: Example for the connection of current sensors 4...20 mA at the analog inputs

**Measuring range 0...20 mA
(active-type sensors with external supply voltage)**

Input currents which exceed the measuring range cause an overflow error message. If the measured value is below the range, an underflow error message is generated.

The input impedance is ca. 330 Ω. The current input has a self-protecting mechanism. If the input current gets too high, the shunt is switched off and the value for range overflow is generated. About every second, the unit tries to switch on the shunt again. In this way the correct measurement will succeed after the current has reached a normal value again.

The trigger of the self-protecting mechanism is displayed by the red LED Ovl as long as the overload is present. In the PLC system an error message is then stored (FK4, error number 4).

The following figure shows the connection of a 3-wire sensor powered by 24 V DC **and** of a 2-pole sensor powered electrically isolated. Both sensors work as **active current sources** 0...20 mA.

It has to be taken into consideration, that in this application the M terminal of the basic unit is the reference potential. AGND1 is not dimensioned for carrying the sum of the sensor currents.

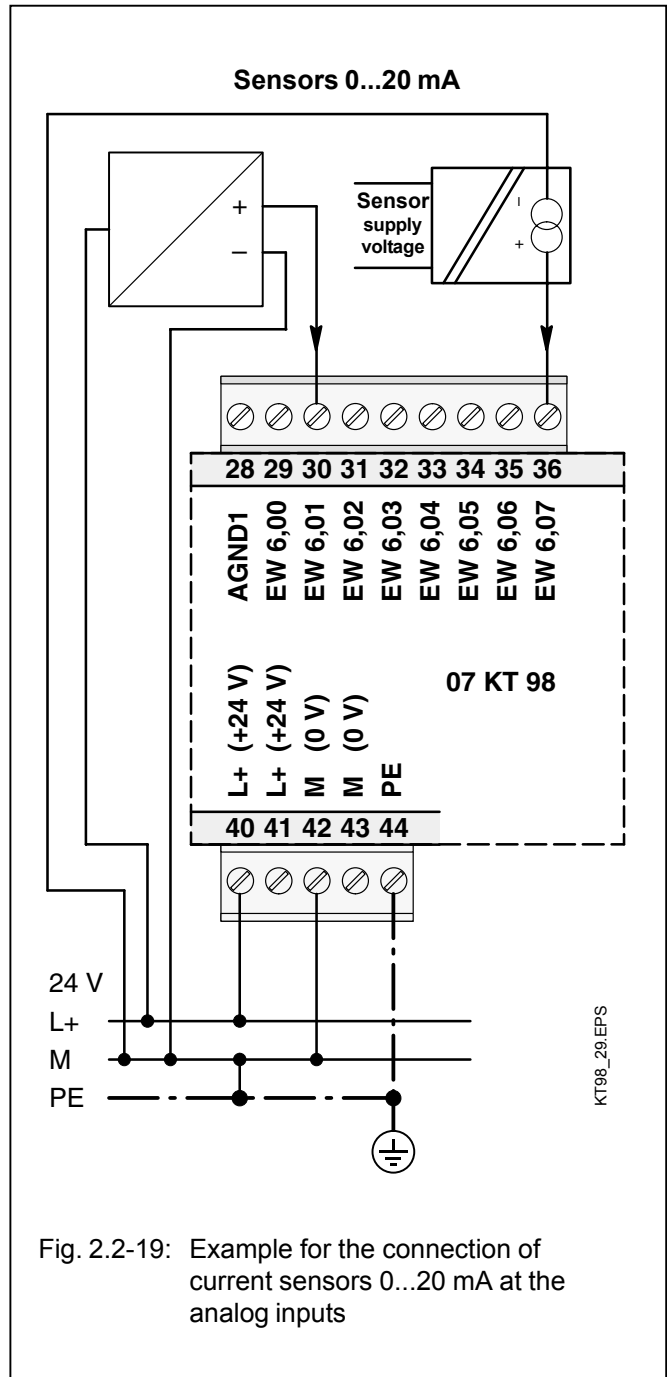

Fig. 2.2-19: Example for the connection of current sensors 0...20 mA at the analog inputs

Measuring ranges $\pm 10\text{ V}$ / $\pm 5\text{ V}$ / $0\text{...}10\text{ V}$ / $0\text{...}5\text{ V}$ as differential inputs

Differential inputs are very useful, if analog sensors are used which are remotely non-isolated (e.g. the minus terminal is remotely earthed).

Since the earthing potential is not exactly the same as AGND1, it has to be measured bipolar in order to compensate measuring errors. Additionally, in case of single-pole configuration, AGND1 would be connected directly to the remote earth potential. This would cause inadmissible (and possibly dangerous) earthing loops.

In all configurations using **differential inputs** two adjacent analog inputs belong together (e.g. EW 6,00 and EW 6,01).

The measured value is calculated by subtraction. The value of the channel with the lower address is subtracted from the value of the channel with the higher address.

The converted measured value is available on the odd address (e.g. EW 6,01).

Important:

The common mode input voltage range equals the measuring range of the single channel. I.e. that the signals, related to AGND, at the two involved inputs must not exceed this measuring range.

Input voltages which exceed the measuring range cause an overflow error message. If the measured value is below the range, an underflow error message is generated.

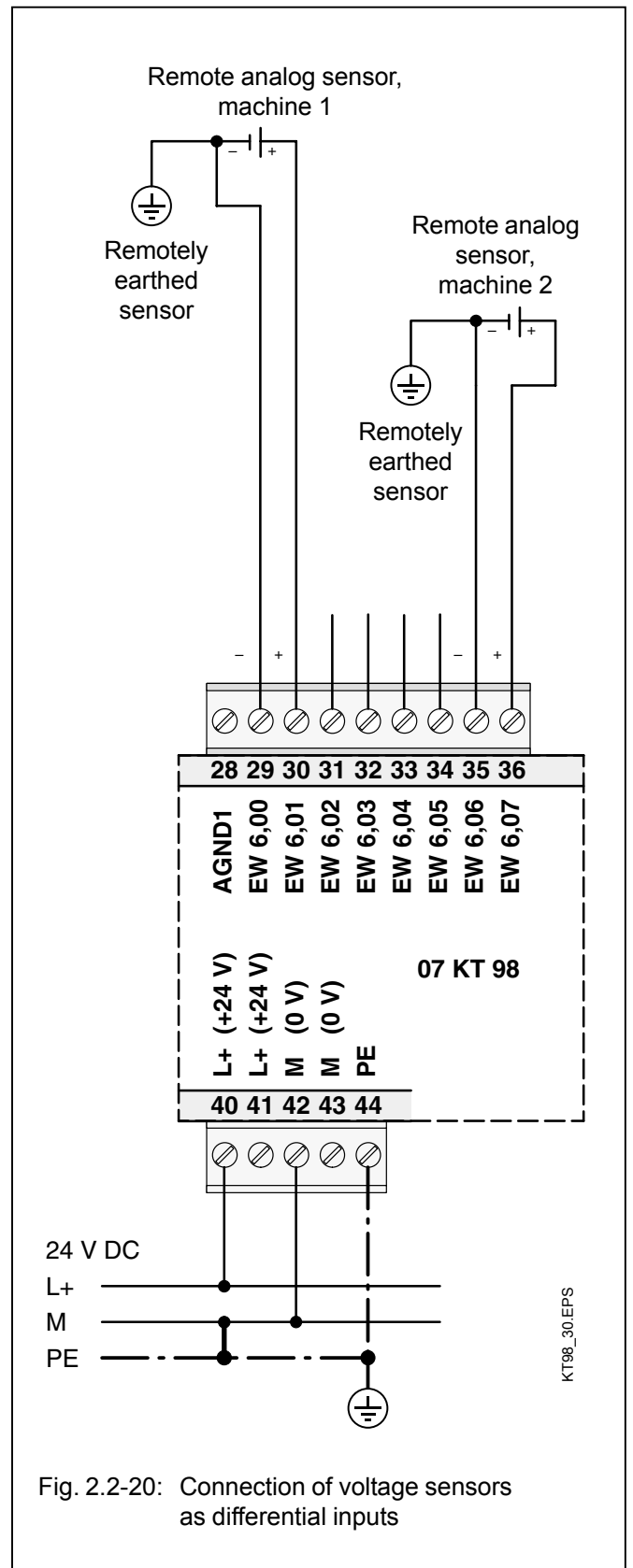

Measuring ranges $-50^{\circ}\text{C}...+400^{\circ}\text{C}$ and $-50^{\circ}\text{C}...+70^{\circ}\text{C}$ with Pt100 as temperature sensor in 2-wire configuration

When resistance thermometers are used, a constant current must flow through the measuring resistor in order to create the necessary voltage drop for the evaluation. For this purpose, the basic unit 07 KT 98 provides a constant current sink, which is multiplexed to the 8 analog channels.

The following figure shows the connection of Pt100 resistance thermometers in **2-wire configuration**.

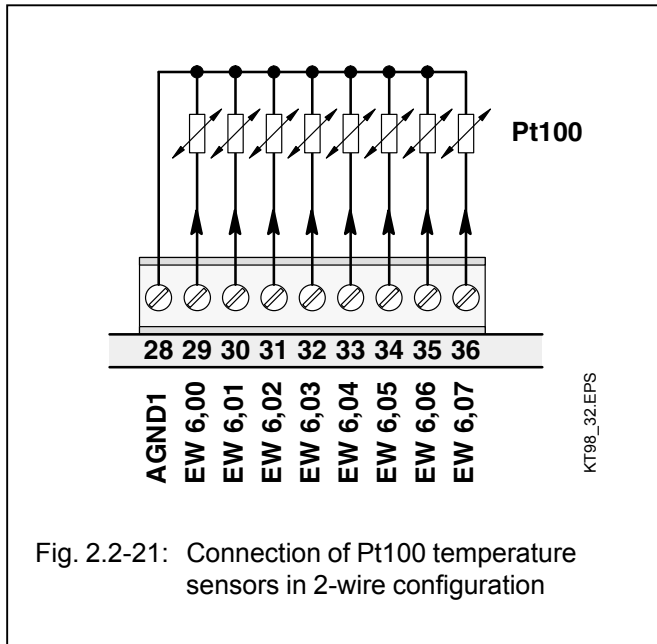

Fig. 2.2-21: Connection of Pt100 temperature sensors in 2-wire configuration

Depending on the configured operating mode, the measured value is assigned linearly as follows:

Range	assigned numerical value range
$-50\text{ C}...400^{\circ}\text{C}$	$-1022...+8190$ (FC02 _H ...1FFE _H)
$-50\text{ C}...70^{\circ}\text{C}$	$-1022...+1433$ (FC02 _H ...0599 _H)

The basic unit linearizes the Pt100 characteristic.

Temperatures which exceed the measuring range cause an overflow error message. If the measured value is below the range, an underflow error message is generated.

A detected open-circuit causes an overflow error message. If the sensor is short-circuited, an underflow error message is generated.

If the open-circuit or short-circuit monitoring is configured, the detected error is displayed by the red LED OvI as long as it is present. In the PLC system an error message is stored (FK4, error number 9).

In order to avoid error messages with unused analog inputs, it is useful, **not** to configure this channels for Pt100.

Measuring ranges $-50^{\circ}\text{C}...+400^{\circ}\text{C}$ and $-50^{\circ}\text{C}...+70^{\circ}\text{C}$ with Pt100 as temperature sensor in 3-wire configuration

The following figure shows the connection of Pt100 resistance thermometers in **3-wire configuration**.

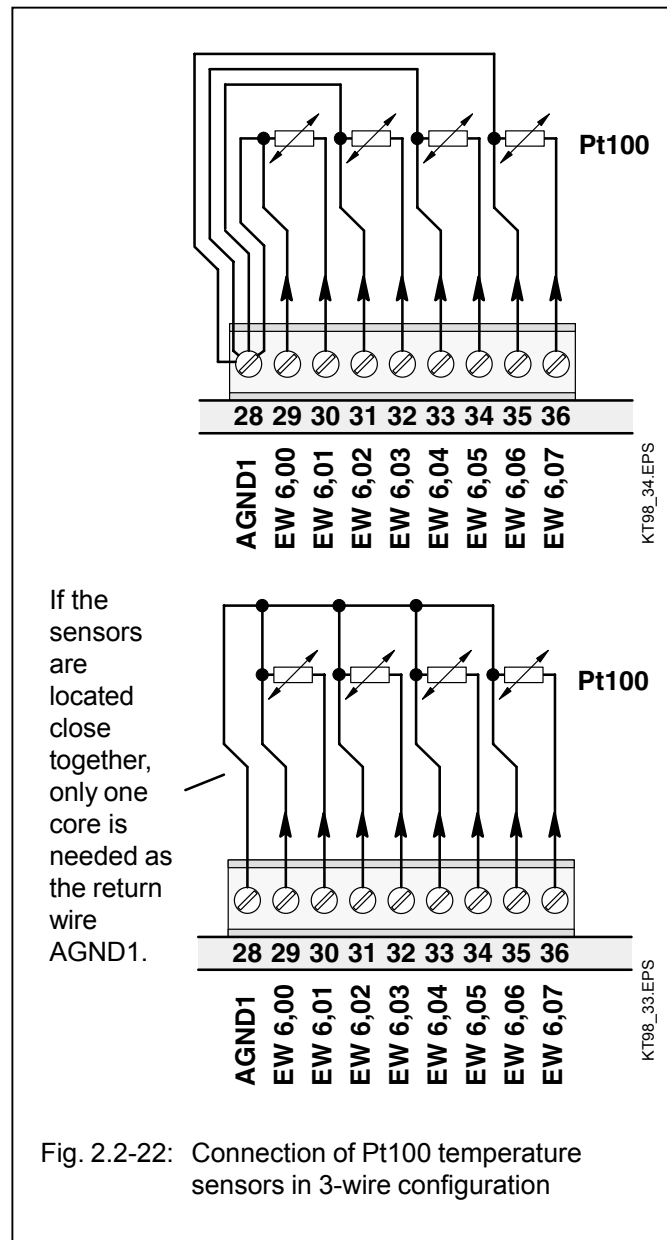

Fig. 2.2-22: Connection of Pt100 temperature sensors in 3-wire configuration

In the operating mode "**Pt100 in 3-wire configuration**" two adjacent analog inputs belong together (e.g. EW 6,00 and EW 6,01).

For configuration, both inputs must be configured to the desired operating mode.

The constant current of the one channel flows through the Pt100 resistance sensor, the constant current of the other channel through one of the wires.

The basic unit calculates the measuring value from the two voltage drops and stores it under the odd address (e.g. EW 6,01).

In order to avoid measurement errors, it is absolutely necessary, to lead the cores to the Pt100 sensors in the same cable. The cores must have the same cross section. Per channel, a twisted pair is used (for the two terminals of the Pt100 sensors) plus a single core (half of a twisted pair) for the connection to AGND1.

Depending on the configured operating mode, the measured value is assigned linearly as follows:

Range	assigned numerical value range
-50 C...400°C	-1022...+8190 (FC02 _H ...1FFE _H)
-50 C...70°C	-1022...+1433 (FC02 _H ...0599 _H)

The basic unit linearizes the Pt100 characteristic.

Temperatures which exceed the measuring range cause an overflow error message. If the measured value is below the range, an underflow error message is generated.

A detected open-circuit causes an overflow error message. If the sensor is short-circuited, an underflow error message is generated.

If the open-circuit or short-circuit monitoring is configured, the detected error is displayed by the red LED Ovl as long as it is present. In the PLC system an error message is stored (FK4, error number 9).

In order to avoid error messages with unused analog inputs, it is useful, **not** to configure this channels for Pt100.

Use of analog inputs as digital inputs

Several (or all) analog inputs can be configured as digital inputs. When doing so, they evaluate input voltages higher than ca. +7 V as signal 1. The input impedance in this operating mode is about 4 kΩ. Terminal M is the reference potential.

The input signal delay is 7 ms. It cannot be configured. The inputs are not electrically isolated.

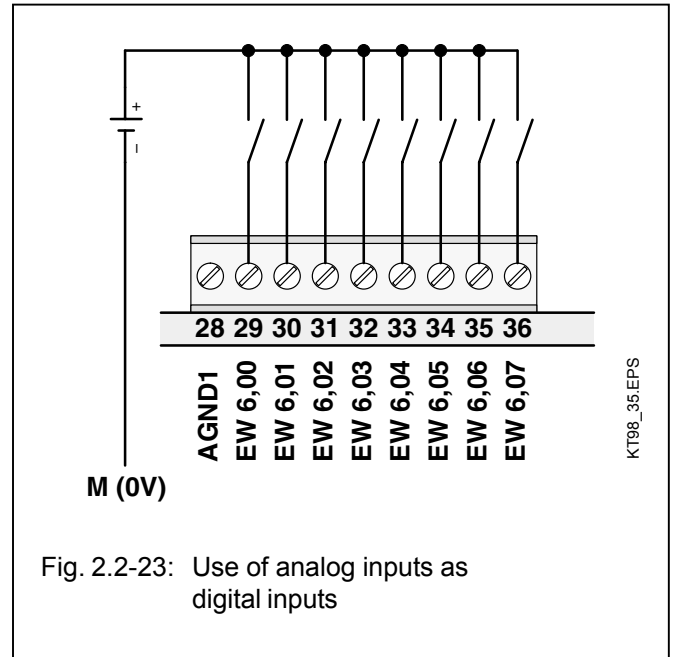
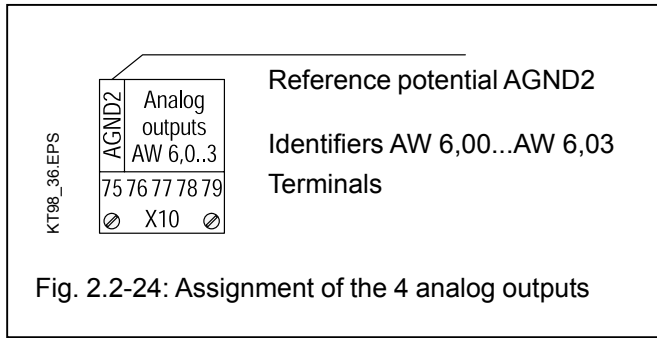

Fig. 2.2-23: Use of analog inputs as digital inputs

KT98_35.EPS

2.2.4.8 Connection of the 4 configurable analog outputs

The following figure shows the assignment of the 4 configurable analog outputs.



Features of the analog outputs:

- The 4 analog outputs are **not** electrically isolated..
- Resolution in the control system:
All analog output values are converted with a resolution of 12 bits, i.e either 11 bits plus sign or 12 bits without sign.
- Analog signals are conducted in shielded cables (see Fig. 2.2-5).
- The analog outputs can be used individually in a lot of different operating modes. The operating modes can be configured with system constants.
- Unused output channels may be left unconnected.

In the following, an application example for an analog receiver is shown.

Output ranges $\pm 10\text{ V}$ / $0\text{...}20\text{ mA}$ / $4\text{...}20\text{ mA}$

In case of voltage outputs the max. output current is $\pm 3\text{ mA}$. The output is short-circuit proof.

In case of current outputs, the range of permissible output load resistors is $0\text{...}500\ \Omega$. If in case of an error the outputs are switched off, this means the following:

Configuration $\pm 10\text{ V}$ 0 V
 Configuration $0\text{...}20\text{ mA}$ 0 mA
 Configuration $4\text{...}20\text{ mA}$ 0 mA .

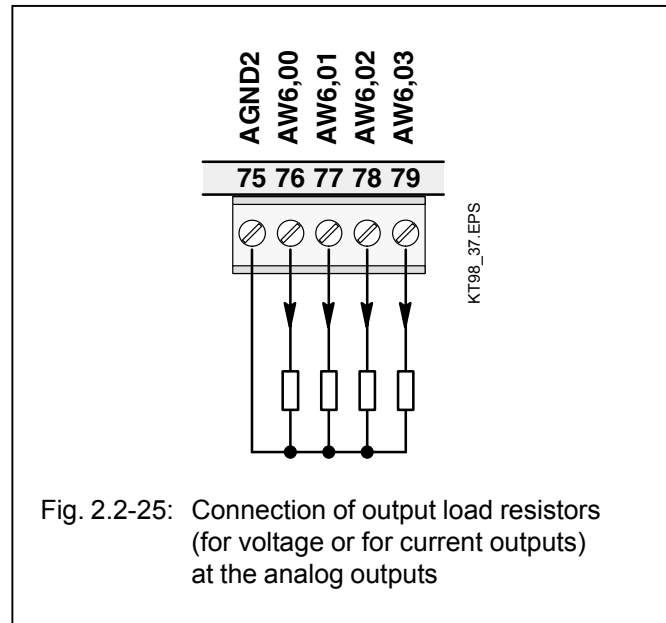

Circuit configuration of an analog output

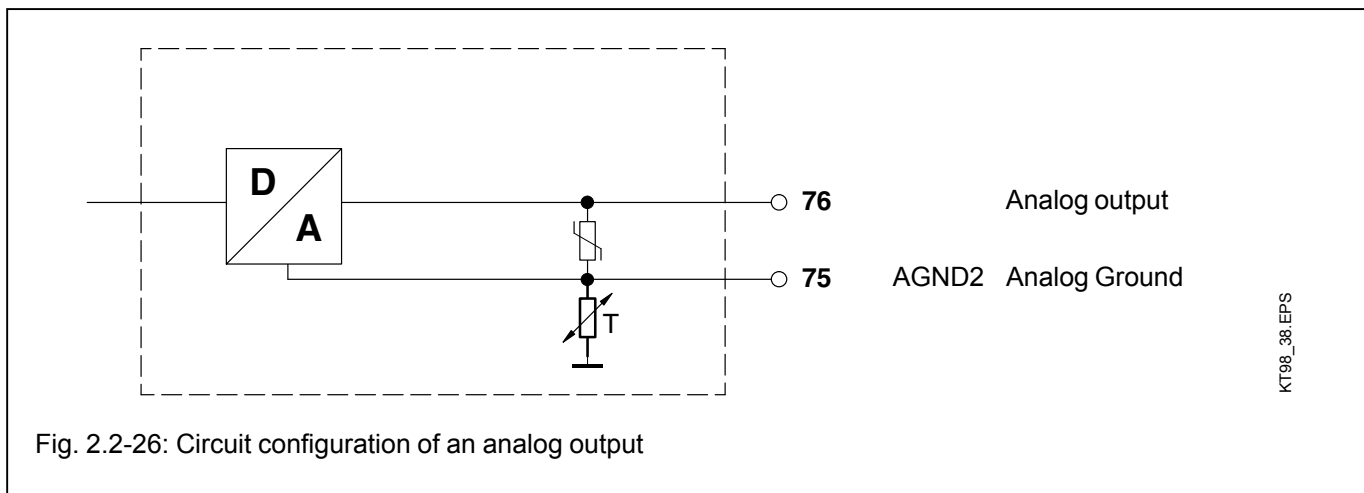

2.2.4.9 Battery and battery replacement

- The lithium battery 07 LE 90 can be inserted into the battery compartment in order to
 - backup data of user program in RAM
 - backup data of additionally in RAM contained information, e.g. flag statuses (RETAIN)
 - backup of time and date

The battery lifetime is typ. 5 years at 25°C. The battery lifetime is the time during which the device remains operable in order to backup data while the supply voltage of the basic unit is switched off. As long as there is a supply voltage available, there is no more load on the battery other than its own leakage current.

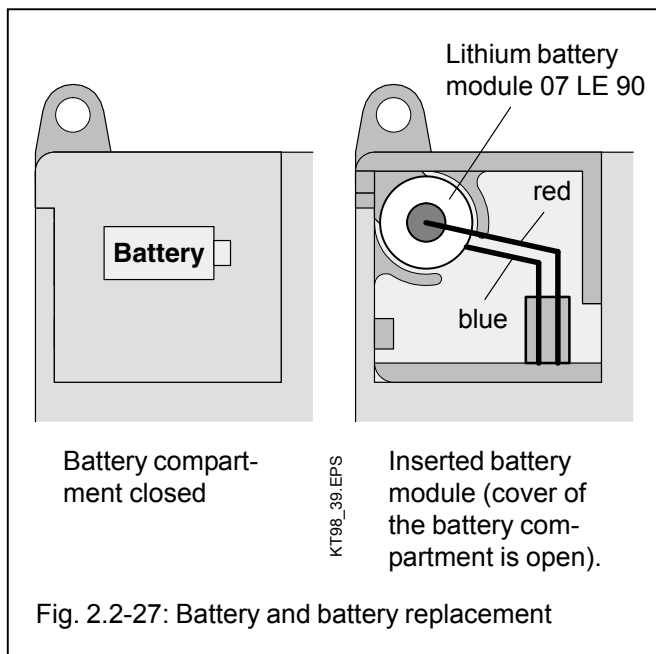

2.2.4.10 Serial interface COM1

Interface standard: EIA RS-232

Assignment of the serial interface COM1

The serial interface COM1 has the following pin assignment:

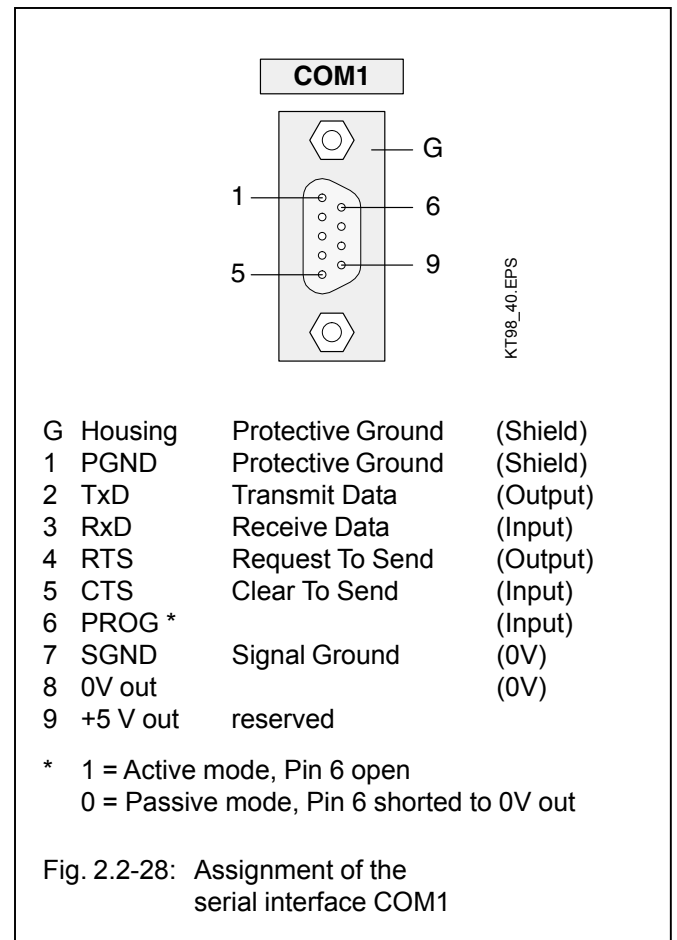

The following handling notes have to be observed:

- Use only lithium batteries approved by ABB.
- Replace the battery by a new one at the end of its life.
- **Never short-circuit the battery!**
There is danger of overheating and explosion. Avoid accidental short-circuits, therefore do not store batteries in metallic containers or boxes and do not bring them into contact with metallic surfaces.
- **Never try to charge a battery!**
Danger of overheating and explosion.
- **Replace the battery only with the supply voltage switched on!**
Otherwise you risk data being lost.
- **Dispose of battery environmentally consciously!**
- If no battery is inserted or if the battery is exhausted, the red LED "Battery" lights up.

2.2.4.11 Serial interface COM2

Interface standard: EIA RS-232

Assignment of the serial interface COM2

The serial interface COM2 has the following pin assignment:

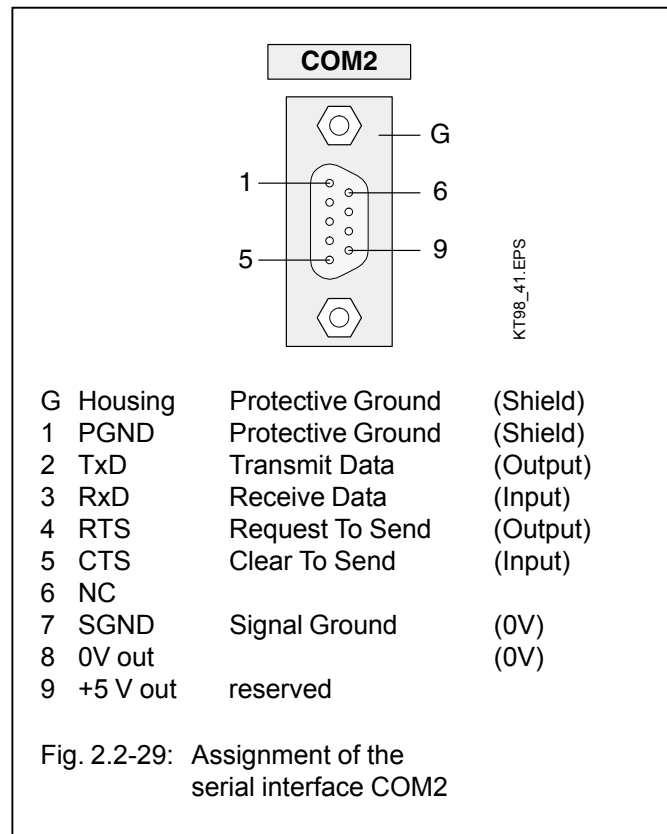

2.2.4.12 Networking interface

The 07 KT 98 basic unit is equipped with a special parallel interface. It is thus possible to network it with another bus system using an additional communication processor module.

The additional communication processor has its own housing. Both housings (of the 07 KT 98 and of the communication processor) are assembled by means of a snap-on connection.

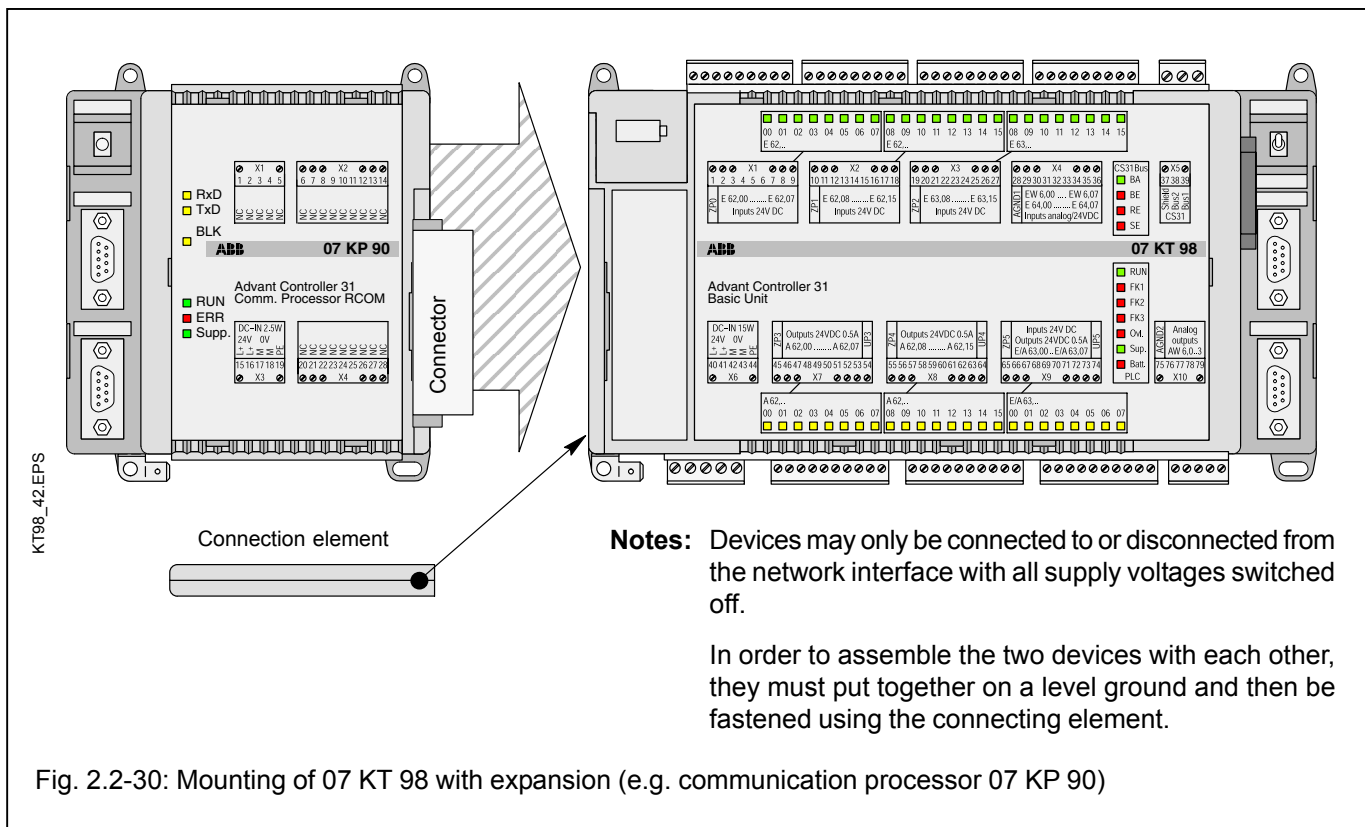

2.2.5 SmartMedia Card 07 MC 90

The SmartMedia Card serves for storing data up to 2 MB or 8 MB not being lost over an power OFF/ON cycle. It is used in the 07 KT 95...98 and 07 SL 97 basic units. It is recommended only to use ABB-proven SmartMedia Cards.

Field of application

- Storing and loading of PLC programs
- Storing and loading of user data
- Loading of firmware updates

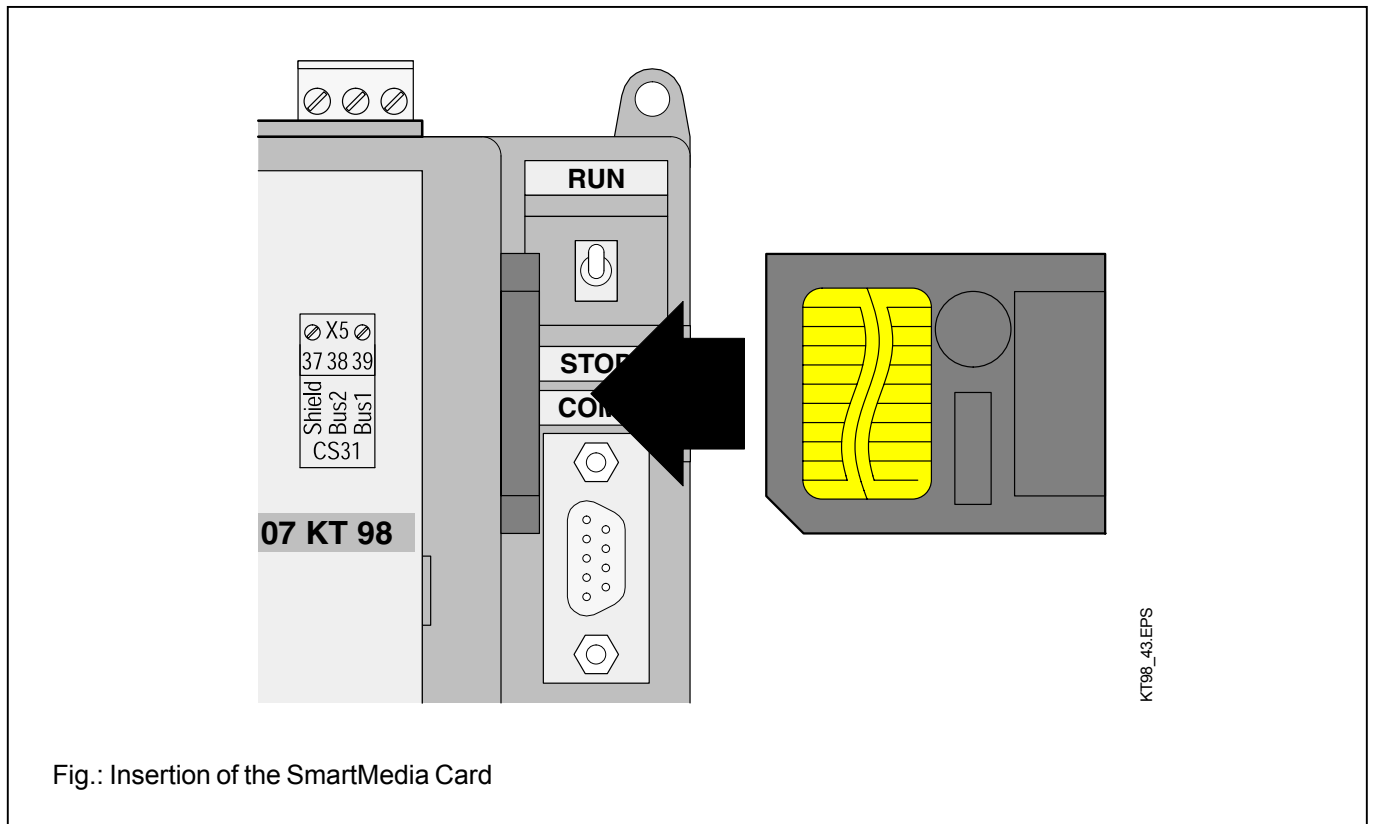

Handling instructions

- The SmartMedia Card is inserted with the contact field visible (see the figure above).
- A SmartMedia Card, once initialized as user data memory, can no more be used as a user program card.
- The SmartMedia Card must be protected from
 - mechanical stress (e.g. do not bend)
 - electrostatic discharge
 - contact pollution (do not touch the contacts)

Important note

SmartMedia Cards with a supply voltage of 3.3 V cannot be used with basic units of the versions R01xx. They also cannot be used with 07 SL 97 basic units (see Usability).

Access

- Access within the PLC program is possible with function blocks, see documentation of the programming software.

Usability

SmartMedia Card 07 MC 90 **5 V** GJR5 2526 00 **R0101** (supply voltage 5 V, usable with the basic units 07 SL 97, 07 KT 95 to 07 KT 98 **R 01xx** and **R02xx**, all firmware versions, memory capacity 2 MB)

SmartMedia Card 07 MC 90 **3,3 V** GJR5 2526 00 **R0201** (supply voltage 3.3 V, usable with the basic units 07 KT 95 to 07 KT 98 **R02xx** with firmware versions as of V5.0, memory capacity 8 MB)

Technical data

Weight	2 g
Dimensions	45 x 37 x 0.7 mm

Order numbers

07 MC 905 V	2 MB	GJR5 2526 00 R0101
07 MC 903.3 V	8 MB	GJR5 2526 00 R0201

2.2.6 High-speed counter

Features

The high-speed counter used in the basic unit 07 KT 98 works independently of the user program and is therefore able to respond quickly to external signals. It can be used in seven different and configurable operating modes.

The desired operating mode is set in a system constant (see documentation part "System technology"). The configured operating mode is only activated during initialization (power-on, cold start, warm start). For all operating modes, the same function block **COUNTW** is used (see programming software).

Independent of the selected operating mode, the following features are valid:

- The pulses at the counter input or the evaluated signals at tracks A and B in case of connection of incremental position sensors are counted.
- The maximum counting frequency is 50 kHz.
- The counter uses the terminals 2 (E 62,00) and 3 (E 62,01) as fast inputs and, in one operating mode, also the output terminal 46 (A 62,00). In order to make all binary inputs and outputs available for other purposes than counting, it is possible, to disable the 07 KT 98's counting function.
- The counter can count upwards in all operating modes, in some modes it also can count downwards. The counting range is from -32768 to $+32767$ or from 8000_H to $7FFF_H$.

2.2.7 Technical Data 07 KT 98

In general, the technical system data listed under "System data and system configuration" in chapter 1 of volume 2 of the Advant Controller 31 system description are valid. Additional data or data which are different from the system data are listed as follows.

2.2.7.1 General data

Number of digital inputs		24
Number of digital transistor outputs		16
Number of digital inputs/outputs		8
Number of analog inputs		8
Number of analog outputs		4
I/O expansion via CS31 system bus by up to		992 digital inputs 992 digital outputs 224 analog input channels 224 analog output channels max. 31 remote modules altogether
Number of serial interfaces		2 (for programming or connection to man-machine communication)
Number of parallel interfaces		1 special interface for connection of a communication processor (for networking with other bus systems)
Integrated memory	Flash EPROM SRAM DRAM	1 MB program + 128 kB user data 256 kB RETAIN 1 MB program + 1 MB user data
Resolution of the integrated real-time clock		1 second
Data of the integrated high-speed hardware counter		
Number of operating modes		7
Counting range		-32768...+32767 (16 bits signed integer)
Counting frequency		max. 50 kHz
Processing time, 65 % bits, 35 % words		typ. 0.07 ms/kB program
Number of software timers		any
delay time of the timers		1 ms...24.8 days
Number of up/down counter software blocks		any
Number of bit flags	in the addressable flag area	8192
Number of word flags	"	8192
Number of double word flags	"	1024
Number of step chains	"	256
Number of constants KW	"	1440
Number of constants KD	"	384
Indication of operating statuses and errors		60 LEDs altogether
Wiring method		removable screw-type terminal blocks
Power supply, CS31 system bus		max. 1 x 2.5 mm ² or max. 2 x 1.5 mm ² (see also page 2.2-9)
all other terminals		max. 1 x 1.5 mm ²
2.2.7.2 Power supply		
Rated supply voltage		24 V DC
Current consumption		max. 0.55 A
Protection against reversed polarity		yes

2.2.7.3 Lithium battery

Battery for backup of RAM contents

Battery module 07 LE 90

Lifetime at 25°C

typ. 5 years

2.2.7.4 Digital inputs

Number of channels per module

24

Distribution of channels into groups

3 groups of 8 channels each

Common reference potential

for group 1 (8 channels)

ZP0 (channels 62,00...62,07)

for group 2 (8 channels)

ZP1 (channels 62,08...62,15)

for group 3 (8 channels)

ZP2 (channels 63,08...63,15)

Electrical isolation

between the groups,
between groups and other circuitry
(see also Fig. 2.2–4)

Signal coupling of input signals

with optocoupler

Configuration possibilities of the inputs

Input signal delay

typ. 7 ms (configurable to 1 ms)

Channels E 62,00 and 62,01

configurable for the high-speed counter

Signalling of input statuses

one green LED per channel,
the LEDs correspond functionally to the input signals

Input signal voltage

Signal 0

-30 V...+ 5 V

Signal 1

+13 V...+ 30 V

Input current per channel

Input voltage = +24 V

typ. 7.0 mA

Input voltage = + 5 V

> 0.2 mA

Input voltage = +13 V

> 2.0 mA

Input voltage = +30 V

< 9.0 mA

Max. cable length, unshielded

600 m

Max. cable length, shielded

1000 m

2.2.7.5 Digital outputs

Number of channels per module

16 transistor outputs

Distribution of channels into groups

2 groups of 8 channels each

Common supply voltage

for group 1

UP3 (channels 62,00...62,07)

for group 2

UP4 (channels 62,08...62,15)

Electrical isolation

between the groups,
between groups and other circuitry
(see also Fig. 2.2–4)

Signalling of output statuses

one yellow LED per channel,
the LEDs correspond functionally to the output signals

Output current

Rated value

500 mA with UP3/4 = 24 V

Maximum value

625 mA with UP3/4 = 24 V + 25%

Leakage current with signal 0

< 0.5 mA

Demagnetization of inductive loads

internally with a varistor

Switching frequency with inductive loads

max. 0.5 Hz

Switching frequency with lamp loads

max. 11 Hz with max. 5 W

Max. cable length	400 m (pay attention to voltage drops)
Short-circuit proof / overload proof	yes
Protection of the outputs against reversed polarity	yes
Forcing of 24 V DC at the outputs possible	yes
Total load (via UP3 or UP4)	max. 4 A
2.2.7.6 Digital inputs/outputs	
Number of channels per module	8 inputs/outputs
Distribution of channels into groups	1 group with 8 channels
Common reference potential	ZP5 (channels E/A 63,00...E/A 63,07)
Common voltage supply	UP5 (channels E/A 63,00...E/A 63,07)
Electrical isolation	between the group and other circuitry (see Fig. 2.2-4)
Signal coupling of the input signals	with optocoupler
Configuration possibilities of the inputs	
Input signal delay, channels E 63,00...E 63,07	typ. 7 ms (configurable to 1 ms)
Signalling of input/output statuses	one yellow LED per channel, the LEDs correspond functionally to the I/O signals
Input signal voltage (if used as inputs)	for details see Fig. 2.2-13 as well as the chapter "Circuit configuration of the digital inputs/outputs"
Signal 0	-6 V...+ 5 V
Signal 1	+13 V...+ 30 V
Input current per channel	see Digital inputs
Output current / switching frequency / inductive loads	see Digital outputs
Max. cable length	see Digital inputs/outputs
2.2.7.7 Analog inputs	
Number of channels per module	8
Distribution of channels into groups	1 group with 8 channels
Common reference potential for group 1 (8 channels)	AGND1 (channels 06,00...06,07)
Electrical isolation	none (see also Fig. 2.2-4).
Max. permissible potential difference between Terminal M (minus pole of the power supply voltage) and terminal AGND (analog I/O minus pole)	± 1 V
Signalling of input statuses	none
Configuration possibilities (each channel), see 2.2.4.7	0...10 V, 0...5 V, ±10 V, ±5 V (also with differential signal) 0...20 mA, 4...20 mA Pt100 -50...+400°C and -50...+70°C (2-wire and 3-wire configuration) digital input
Input impedance per channel, voltage input	> 100 kΩ
current input	ca. 330 Ω
digital input	ca. 4 kΩ

The current input has a self-protecting mechanism. If the input current gets too high, the shunt is switched off and the value for range overflow is generated. About every second, the unit tries to switch on the shunt again. In this way the correct measurement will succeed after the current has reached a normal value again.

Time constant of the input filter	470 µs with voltage, 100 µs with current
Conversion cycle of current and voltage channels	Each configured input channel (U, I, Pt100) increases the conversion cycle of the U/I channels by typ. 1 ms.
Conversion cycle (by filtering time) of Pt100 channels	Each configured input channel (U, I, Pt100) increases the conversion cycle of the Pt100 channels by typ. 50 ms.
Conversion cycle of unused input channels	Input channels configured as "unused" are skipped, i.e. they do not need any conversion time.

Examples for the conversion cycle

Example No.	1	2	3	4	5	6
Channels configured for U/I	1	8 *	-	-	2	4
Channels configured for Pt100	-	-	4	8	2	4
Channels configured as "unused"	7	-	4	-	4	-
Conversion cycle of U/I channels	1 ms	8 ms	-	-	4 ms	8 ms
Conversion cycle of Pt100 channels	-	-	200 ms	400 ms	200 ms	400 ms

* Factory setting

Resolution in bits	ranges ±10 V, 0...10 V ranges ±5 V, 0...5 V ranges 0...20 mA, 4...20 mA range -50 °C...+70 °C range -50 °C...+400 °C	11 bits plus sign 10 bits plus sign 12 bits without sign 10 bits plus sign 11 bits plus sign
Resolution in mV, µA	range ±10 V range 0...10 V range 0...20 mA range 4...20 mA	ca. 5 mV ca. 5 mV ca. 5 µA ca. 4 µA
Relationship between input signal and hex code		$-100\% \dots 0\% \dots +100\% = 8008_{\text{H}} \dots 0000_{\text{H}} \dots 7FF8_{\text{H}}$ (-32760...0...32760 decimal)
Conversion inaccuracy caused by non-linearity, temperature sensitivity, ageing, adjustment error on delivery and resolution:	U, I Pt100	typ. 0.5 %, max. 1 % typ. 1 °C, max. 2 °C
Threshold, if analog input is configured as digital input		ca. 7 V
Max. cable length, 2-core shielded and cross section ≥ 0,5 mm ²		100 m

2.2.7.8 Analog outputs

Number of channels per module	4
Reference potential	AGND2 (channels 06,00...06,03)
Electrical isolation	none (see also Fig. 2.2-4).
Max. permissible potential difference between Terminal M (minus pole of the power supply voltage) and terminal AGND (analog I/O minus pole)	± 1 V

Signalling of output statuses	none
Output signal ranges (configurable)	-10 V...0...+10 V 0...20 mA 4...20 mA
Output load capability of the voltage outputs	max. ±3 mA
Resolution	12 bits
Resolution (1 LSB), range -10 V...0...+10 V	5 mV
Relationship between output signal and hex code	-100 %...0...+100 % = 8008 _H ...0000 _H ...7FF8 _H (-32760...0...32760 decimal)
Conversion cycle for outputs	typ. 1 ms for each configured output channel
Conversion inaccuracy caused by non-linearity, temperature sensitivity, ageing, adjustment error on delivery and resolution	typ. 0.5 %, max. 1 %
Max. cable length, 2-core shielded and cross section ≥ 0,5 mm ²	100 m

2.2.7.9 Connection of serial interfaces COM1 and COM2

Interface standard	EIA RS-232
Programming with 907 AC 1131	with IBM PC (or compatible)
Program modifications with 907 AC 1131	with IBM PC (or compatible)
Man-machine communication	yes, e.g. with an operating station
Electrical isolation	versus digital inputs and outputs, versus CS31 system bus interface (see also Fig. 2.2-4)
Potential differences	In order to avoid potential differences between the 07 KT 98 basic unit and the peripheral devices connected to the COM1/COM2 interfaces, these devices are supplied from the switch-gear cabinet socket (see also the earthing connections in Fig. 2.2-5).
Pin configuration and description of the COM1/COM2 interfaces	see chapters 2.2.4.10 and 2.2.4.11

2.2.7.10 Connection to the CS31 system bus

Interface standard	EIA RS-485
Connection as a Master PLC as a Slave PLC	yes, transmitting and receiving areas are configurable yes, see "System constants"
Setting of the CS31 module address	yes, by system constant, stored in Flash EPROM of the Slave PLC
Electrical isolation	versus supply voltage, inputs and outputs, versus interfaces COM1/COM2 (see also Fig. 2.2-4)
Terminal assignment and description of the CS31 bus interface	see chapter 2.2.4.3

2.2.7.11 LED displays

LEDs for indication of:

– Statuses of digital inputs	1 green LED per channel
– Statuses of digital outputs	1 yellow LED per channel
– Statuses of digital inputs/outputs	1 yellow LED per channel
– Power supply on	1 green LED
– Battery	1 red LED
– Program is running (RUN)	1 green LED
– Error classes (FK1, FK2, FK3)	1 red LED per error class
– CS31 system bus is running (BA)	1 green LED
– bus-specific errors (BE, RE, SE)	3 red LEDs
– Overload/short-circuit of digital outputs	1 red LED

2.2.7.12 High-speed hardware counter

Data of the integrated high-speed hardware counter:

Configurable	in 7 operating modes
Counting range	-32768...+32767 (16 bits)
Counting frequency	max. 50 kHz
Used inputs	E 62,00 and E 62,01
Used outputs	A 62,00

2.2.7.13 Mechanical data

Mounting on DIN rail	according to DIN EN 50022–35, 15 mm deep. The DIN rail is located in the middle between the upper and the lower edge of the module.
Fastening by screws	with 4 screws M4.
Width x height x depth	240 x 140 x 85 mm
Wiring method	by removable terminal blocks with screw-type terminals
Power supply terminals, CS31 system bus	max. 1 x 2.5 mm ² or max. 2 x 1.5 mm ²
All other terminals	max. 1 x 1.5 mm ²
Weight	1.6 kg
Dimensions for mounting	see the following drawing

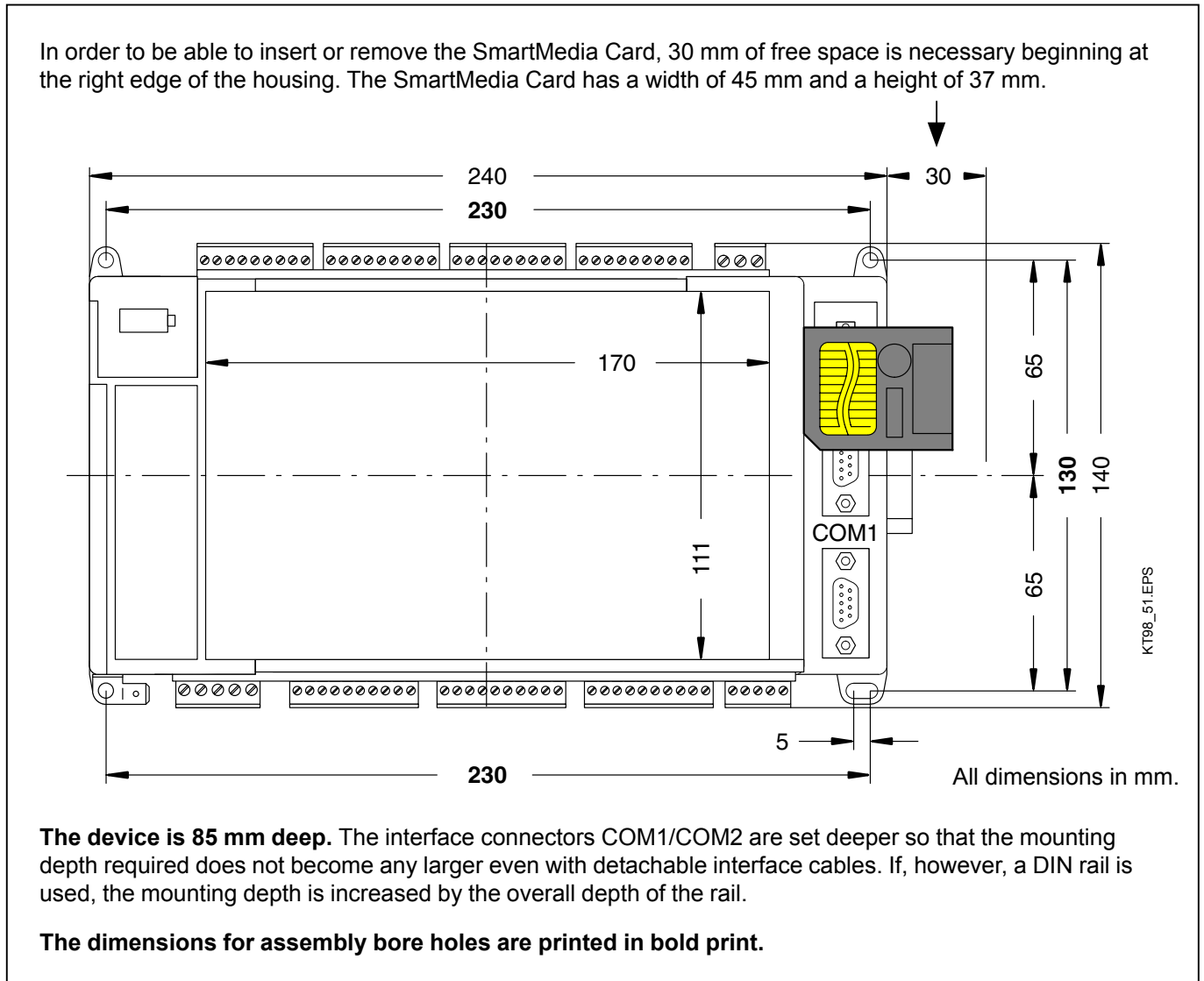

2.2.7.14 Mounting hints

Mounting position	vertical, terminals above and below
Cooling	The natural convection cooling must not be hindered by cable ducts or other material mounted in the switch-gear cabinet.

2.2.7.15 Ordering data

Basic unit 07 KT 98 R0120 (+ PROFIBUS-DP)	Order No. GJR5 2531 00 R0120
Basic unit 07 KT 98 R0220 (+ PROFIBUS-DP)	Order No. GJR5 2531 00 R0220
Basic unit 07 KT 98 R0160 (+ ARCNET)	Order No. GJR5 2531 00 R0160
Basic unit 07 KT 98 R0260 (+ ARCNET)	Order No. GJR5 2531 00 R0260
Basic unit 07 KT 98 R0162 (+ ARCNET + PROFIBUS-DP)	Order No. GJR5 2531 00 R0162
Basic unit 07 KT 98 R0262 (+ ARCNET + PROFIBUS-DP)	Order No. GJR5 2531 00 R0262
Basic unit 07 KT 98 R0268 (+ ARCNET + CANopen)	Order No. GJR5 2531 00 R0268
Basic unit 07 KT 98 R0270 (+ Ethernet)	Order No. GJR5 2531 00 R0270
Basic unit 07 KT 98 R0272 (+ Ethernet + PROFIBUS-DP)	Order No. GJR5 2531 00 R0272
Basic unit 07 KT 98 R0276 (+ Ethernet + ARCNET)	Order No. GJR5 2531 00 R0276
Basic unit 07 KT 98 R0277 (+ Ethernet + Ethernet)	Order No. GJR5 2531 00 R0277
Basic unit 07 KT 98 R0278 (+ Ethernet + CANopen)	Order No. GJR5 2531 00 R0278
Basic unit 07 KT 98 R0280 (+ CANopen)	Order No. GJR5 2531 00 R0280
Scope of delivery	Basic unit 07 KT 98

1 5-pole terminal block (5.08 mm)
1 3-pole terminal block (5.08 mm)
3 10-pole terminal blocks (3.81 mm)
4 9-pole terminal blocks (3.81 mm)
1 5-pole terminal block (3.81 mm)

Accessories

System cable 07 SK 90	Order No. GJR5 2502 00 R0001
System cable 07 SK 91	Order No. GJR5 2503 00 R0001
System cable 07 SK 92	Order No. GJR5 2504 00 R0001
Battery module 07 LE 90	Order No. GJR5 2507 00 R0001
SmartMedia Card 07 MC 90 5.0 V 2 MB	Order No. GJR5 2526 00 R0101
SmartMedia Card 07 MC 90 3.3 V 8 MB	Order No. GJR5 2526 00 R0201

Further literature

System description ABB Procontic CS31 English	Order No. FPTN 4400 04 R2001
System description Advant Controller 31 English	Order No. 1SAC 1316 99 R0201

2.2.11 Description of ARCNET

2.2.11.1 Basic units with integrated ARCNET coupler

07 KT 98 R0160 (ARCNET)	Order No. GJR5 2531 00 R0160
07 KT 98 R0162 (ARCNET + PROFIBUS-DP)	Order No. GJR5 2531 00 R0162
07 KT 98 R0260 (ARCNET)	Order No. GJR5 2531 00 R0260
07 KT 98 R0262 (ARCNET + PROFIBUS-DP)	Order No. GJR5 2531 00 R0262
07 KT 98 R0268 (ARCNET + CANopen)	Order No. GJR5 2531 00 R0268
07 KT 98 R0276 (Ethernet + ARCNET)	Order No. GJR5 2531 00 R0276

2.2.11.2 Technical data

Connector X4	BNC
ARCNET interface	for coaxial cable
Recommended system cable	coaxial cable Type RG-62/U (char. impedance 93 Ω)
Cable length	305 m in case of ARCNET bus with 8 stations. For further details see SMC TECHNICAL NOTE TN7-1.
Signalling	operating condition "controller active", i.e. the PLC performs writing or reading operations
	operating condition "transmit active", i.e. the PLC is sending on the ARCNET
Electrical isolation	versus power supply voltage, inputs and outputs, versus the interfaces COM1/COM2

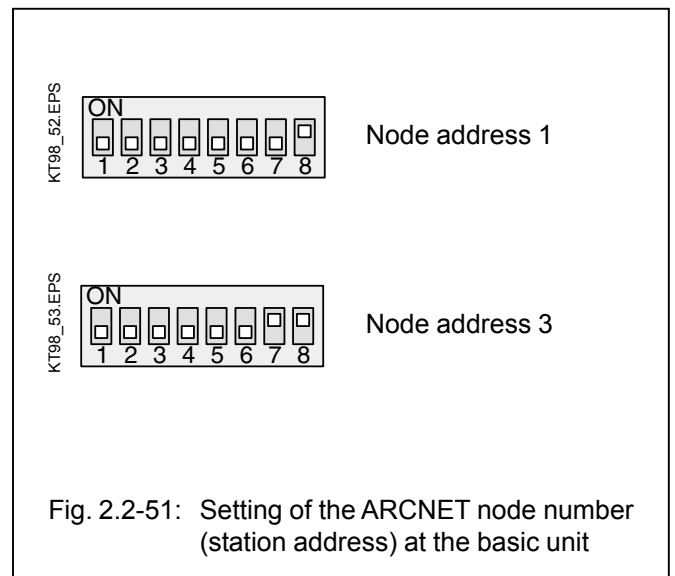
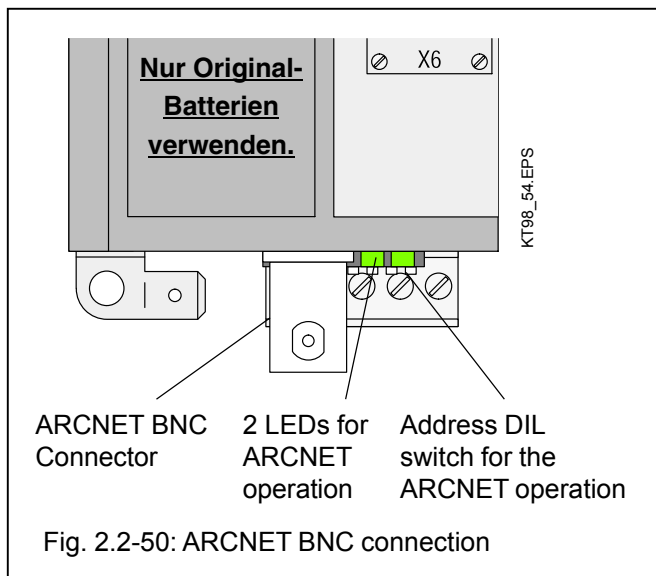

2.2.11.3 ARCNET short description

- The ARCNET coupler is integrated in the housing of the basic unit. The DIL switch for setting the ARCNET address is accessible from the outside of the housing. The ARCNET coupler is powered by the internal 24 V DC supply voltage.
- Note:** The ARCNET interface is located on the upper side of the basic unit if there is also an Ethernet interface integrated.
- For ARCNET coupling, several function blocks are available.
- The ARCNET coupler interface is designed as a bus with BNC connector for coaxial cable. The ARCNET bus is earthed inside the module via a capacitor. As an EMC measure and for protection against dangerous contact voltages, the bus has to be earthed directly at a central place.
- Using the simplest configuration, called Linear ARCNET, a coaxial cable (RG-62, 93 Ω) is laid from station to station and connected with T plugs at all stations. At both ends of the cable, terminating resistors with 93 Ω each have to be installed.

2.2.11.4 The ARCNET system (Attached Resource Computer Network)

- ARCNET is a system for data transmission in local networks.
- The ARCNET protocol is based on the Token Passing principle.
- By passing an identifier (token) from station to station it is guaranteed, that only one station can start a data transmission (transmission without collisions).
- The order of sequence, in which the stations are accessed, is automatically adapted by the existing conditions in the network, i.e. that the network is reconfigured automatically each time a station is added to the network or switched off.

2.2.11.4.1 The networking configurations

Linear ARCNET

- In the Linear ARCNET configuration, the stations are connected to one another directly, i.e. without using any distribution units.
- Each station is connected to the network by using a T connector.
- Both cable ends must be terminated by termination resistors.
- A maximum of 8 stations can be connected to one Linear ARCNET.
- The maximum cable length of the network is 300 m.
- An additional segment can be connected at the end of the wired segment via an Active Hub (active distribution unit), see next page.

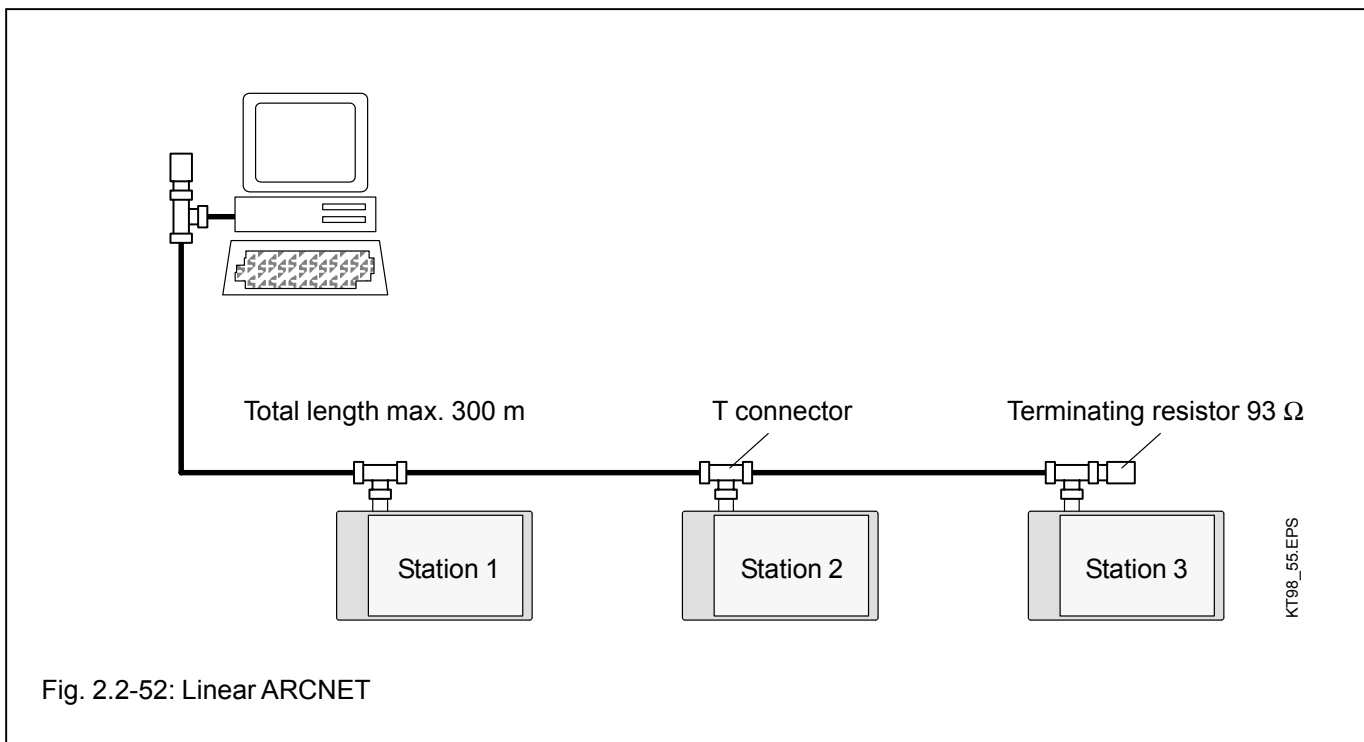

Linear ARCNET, expanded by active distribution units (Active Hubs)

- Active Hubs amplify the arriving signals. So they stabilize the network configuration and allow especially for high distances. The Active Hub decouples the station connectors from one another.

Therefore, the entire network does not fail when one of the connections fails.

- The maximum length of the network is 6 km.
- A maximum of 255 stations can be used.

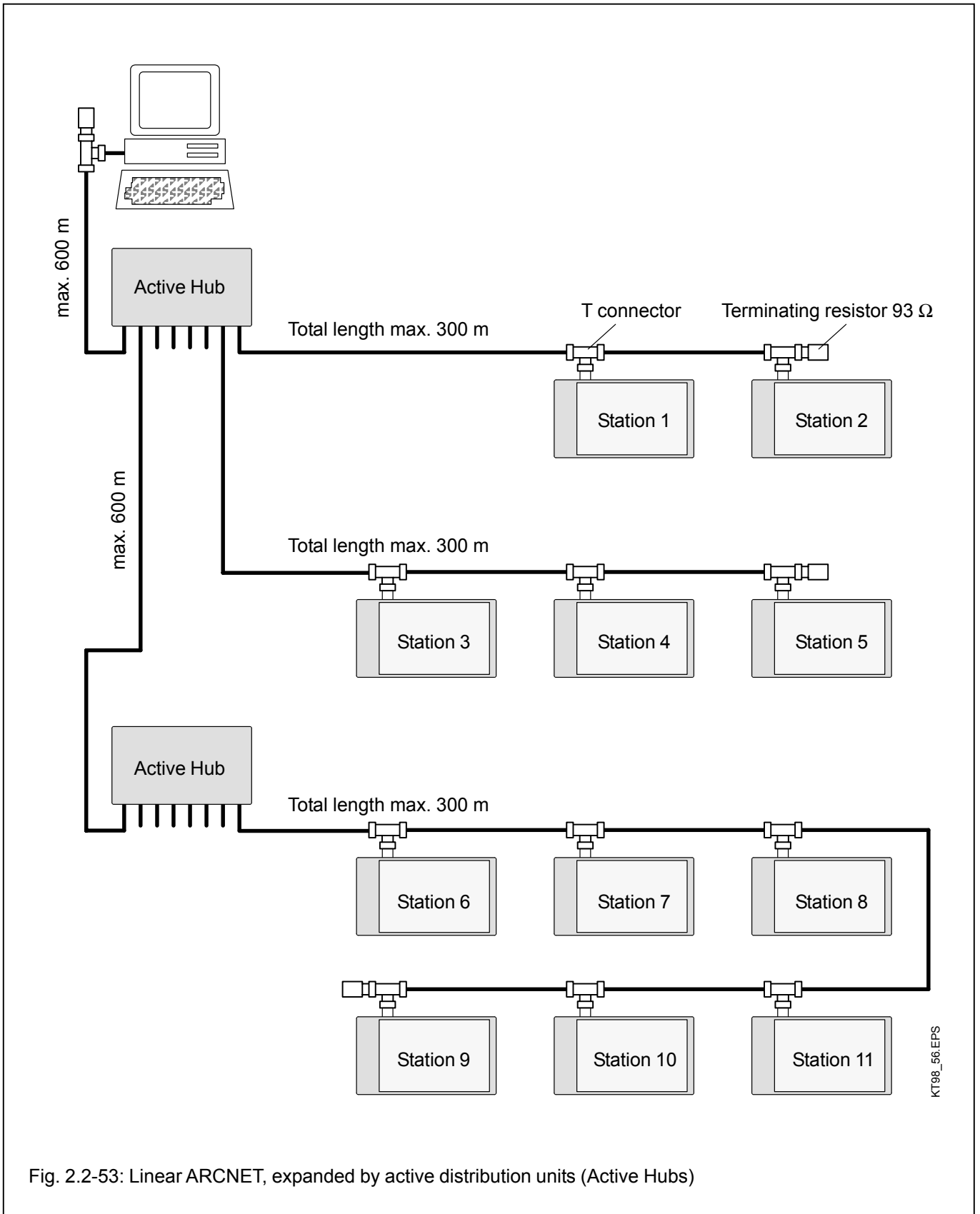

Fig. 2.2-53: Linear ARCNET, expanded by active distribution units (Active Hubs)

KT98_56.EPS

2.2.11.4.2 The features of the ARCNET system

- Data transmission rate 2.5 MBit/s
- Coaxial cable of type RG62/U, 93 Ω
- Coaxial plugs, suitable for the coaxial cable
- Maximum number of stations: 255

Maximum distances

- The maximum distance between two stations amounts to 6 km.
- The maximum distance between an Active Hub and an ARCNET station or between two Active Hubs amounts to 600 m.
- The maximum distance between a Passive Hub and an ARCNET station or between an Active Hub and a Passive Hub is 30 m. A Passive Hub works like a resistor network which carries out the cable termination at the stations.
- The maximum distance within a Linear ARCNET configuration is 300 m. A maximum of 8 stations can be connected.

2.2.12 Description of the PROFIBUS-DP coupler

2.2.12.1 Basic units with integrated PROFIBUS-DP coupler

07 KT 98 R120 (PROFIBUS-DP)	Order No. GJR5 2531 00 R0120
07 KT 98 R162 (ARCNET + PROFIBUS-DP)	Order No. GJR5 2531 00 R0162
07 KT 98 R220 (PROFIBUS-DP)	Order No. GJR5 2531 00 R0220
07 KT 98 R262 (ARCNET + PROFIBUS-DP)	Order No. GJR5 2531 00 R0262
07 KT 98 R272 (Ethernet + PROFIBUS-DP)	Order No. GJR5 2531 00 R0272

2.2.12.2 Technical data of the integrated coupler

Coupler type	PROFIBUS coupler in PC/104 format
Processor	8-Bit processor with interrupt and DMA controller
Memory available	8 kByte DP RAM, 512 kByte Flash EPROM, 368 kByte RAM
Internal supply with	+5 V, 600 mA
Dimensions	96 x 91 x 13 mm

2.2.12.3 Technical data of the interface

Interface connector	9-pole SUB-D, female
Transmission standard	EIA RS-485
Transmission protocol	PROFIBUS-DP
Recommended system cable	shielded and twisted 2-core wire
Characteristic impedance	135...165 Ω
Cable capacitance	< 30 pF/m
Diameter of the wire cores (copper)	> 0.64 mm
Cross section of the cable cores	> 0.32 mm ²
Wire resistance per core	< 55 Ω /km
Loop resistance (resistance of 2 cores)	< 110 Ω /km
Transmission speed (baud rate)	9.6 kBit/s bis 12000 kBit/s
Maximum cable length	1200 m with baud rate 9.6 / 19.2 / 93.75 kBit/s 1000 m with baud rate 187.5 kBit/s 400 m with baud rate 500 kBit/s 200 m with baud rate 1500 kBit/s 100 m with baud rate 3000 / 6000 / 12000 kBit/s
Spur lines	are only permitted up to max. 1500 kBit/s, they should be prevented with 500 kBit/s or more for security purposes
Electrical isolation of the interface	test voltage max. 850 V
Display of statuses	with 4 LEDs (see Fig. 2.2-56)
Number of participants (masters/slaves) per bus segment	max. 32
Number of participants via repeater	max. 126

2.2.12.4 PROFIBUS-DP coupler

Definitions, terms, abbreviations

PROFIBUS-DP	PROCESS FIELDBUS - DECENTRAL PERIPHERY
DP master (class 1)	normal bus master
DP master (class 2)	commissioning device
DP slave (DPS)	I/O module
DPV1	guideline for extended functions for PROFIBUS-DP
PNO	PROFIBUS Nutzer-Organis- sation (user organization)

Standardization

EN 50170, DIN 19245 Part 1, DIN 19245 Part 3, DPV1

Basics

PROFIBUS-DP is intended for fast data exchange in the field area. Here, central control units (e.g. PLC/PC) communicate with decentralized field devices like I/O, drives and valves via a fast serial connection. The data exchange with the decentralized modules is mainly performed cyclically. The communication functions, required for data exchange, are defined by the PROFIBUS-DP basic functions in accordance to EN 50170. For parametrization, diagnosis and alarm handling during the running cyclic data exchange, also non-cyclic communication functions are necessary for intelligent field devices.

Location

The PROFIBUS-DP coupler is integrated in the housing of the basic unit. The bus interface is located on the top side to the left of the basic unit. There are also 4 LEDs for displaying statuses.

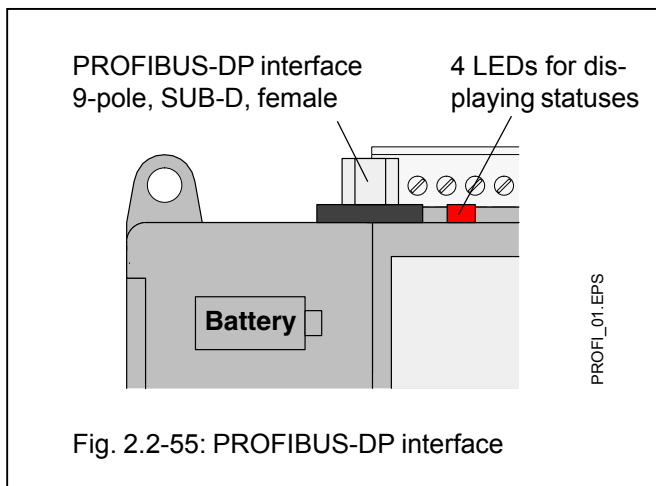

Fig. 2.2-55: PROFIBUS-DP interface

Pin assignment, meaning of the LEDs

The following figure shows the pin assignment of the PROFIBUS-DP interface as well as the names of the 4 LEDs. The drawing is shown looking from the front side (as mounted in the switch-gear cabinet).

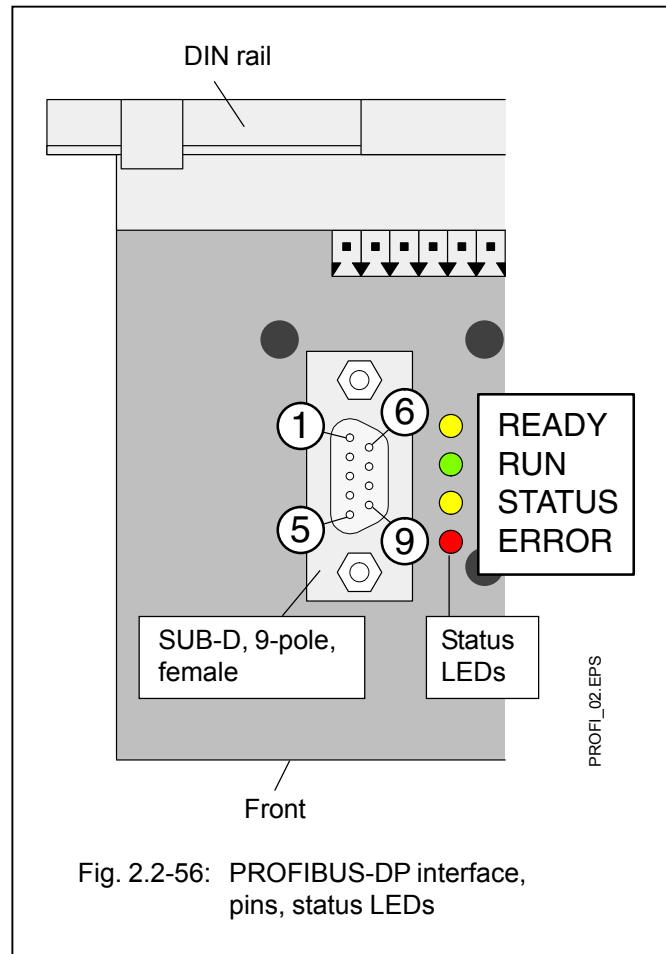

Fig. 2.2-56: PROFIBUS-DP interface, pins, status LEDs

Pin assignment (SUB-D, 9-pole, female)

Pin No.	Signal	Meaning
1	Shield	shielding, protection earth
2	unused	
3	RxD/TxD-P	receive/transmit line, positive
4	CNTR-P	control signal for repeater, positive
5	DGND	reference potential for data exchange and +5 V
6	VP	+5 V (power supply for the bus terminating resistors)
7	unused	
8	RxD/TxD-N	receive/transmit line, negative
9	CNTR-N	control signal for repeater, negative

Bus termination

The line ends (of the bus segments) must be equipped with bus termination resistors (show the drawing to the right). Normally, the resistors are integrated in the interface connectors.

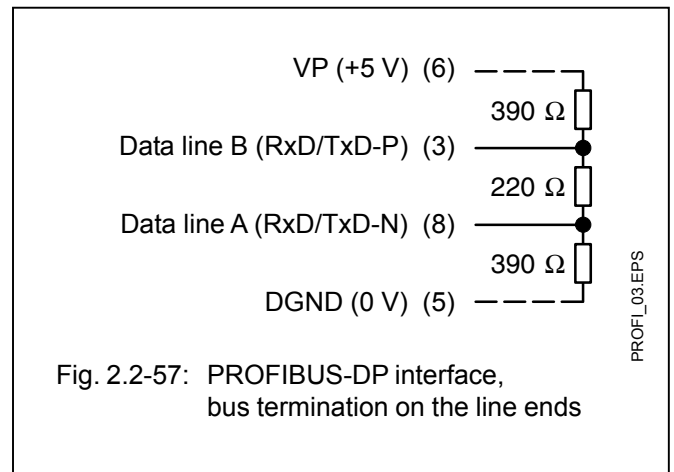

Fig. 2.2-57: PROFIBUS-DP interface, bus termination on the line ends

Status LEDs

LED	Color	Condition	Meaning
READY	yellow	on flashes cyclic flashes non-cyclic off	coupler ready bootstrap loader active hardware or system error defective hardware
RUN	green	on flashes cyclic flashes non-cyclic off	communication is running communication is stalled missing or erroneous configuration no communication
STATUS	yellow	on off	DP slave: data exchange with DP master DP master: transmits data or token DP slave: no data exchange DP master: no token
ERROR	red	on off	PROFIBUS error no error

The condition of the PROFIBUS coupler is indicated with the 4 status LEDs.

After power ON the coupler initializes a self-test. If this test was successful, the yellow READY LED goes ON. Otherwise the LED starts flashing and aborts the further initialization. If the LED remains OFF, the coupler is defective.

In the course of initialization, the RUN LED is OFF for the first time. The LED is only activated after configuration data has been sent to the coupler and the operating mode of the coupler was set. If the operating system of the coupler detects a parameterization or a configuration error, the green RUN LED flashes non-cyclically. If this LED flashes cyclically, the coupler is ready for communication, but the communication is not active yet. In case of an active communication, the RUN LED lights continuously.

The red ERROR LED indicates errors on the PROFIBUS interface.

In the operating mode DP slave, the yellow STATUS LED indicates the active I/O data exchange with the DP master. In the operating mode DP master, the STATUS LED indicates the ownership of the token and therefore the I/O data exchange with the involved DP slaves.

During the initialization procedure and also if the coupler is configured (anew) - in particular if the operating mode was changed - it can occur that all or some LEDs light up for a short period of time, before reaching a defined condition.

Important address

PROFIBUS Nutzerorganisation e. V. (PNO)
Haid-und-Neu-Straße 7
D-76131 Karlsruhe

Tel.: (+49) 721 9658 590

Fax: (+49) 721 9658 589

Internet: <http://www.profibus.com>

2.2.13 Description of the CANopen Master coupler

2.2.13.1 Basic units with an integrated CANopen Master coupler

07 KT 98 R268 (ARCNET + CANopen)	Order No. GJR5 2531 00 R0268
07 KT 98 R278 (Ethernet + CANopen)	Order No. GJR5 2531 00 R0278
07 KT 98 R280 (CANopen)	Order No. GJR5 2531 00 R0280

2.2.13.2 Technical data of the integrated coupler

Coupler type	CANopen Master coupler in PC/104 format
Processor	16-bit processor with interrupt and DMA controller
Memory available	8 kbyte DP-RAM, 512 kbyte Flash EPROM, 128 kbyte RAM
Internal supply with	+5 V, 650 mA
Dimensions	96 x 90 x 23 mm
CE sign	55011 Class b for emission, EN 50082-2 for noise immunity

2.2.13.3 Technical data of the interface

Interface connector	5-pole COMBICON, female
Transmission standard	ISO 11898, isolated
Transmission protocol	CANopen (CAN), max. 1 Mbaud
Transmission speed (baud rate)	20 kbit/s, 125 kbit/s, 250 kbit/s, 500 kbit/s und 1 Mbit/s
Display of statuses	by 4 LEDs (see Fig. 2.2-59)
Number of participants	max. 127 slaves

2.2.13.4 Short description

CANopen is a standardized 7-layer protocol for decentralized industrial automation systems, based on the Controller Area Network (CAN) and the CAN Application Layer (CAL).

CANopen bases on a communication profile in which the basic communication mechanisms and their descriptions are defined, e.g. mechanisms for interchange of process data in real time or transmitting of alarm messages.

The different CANopen device profiles make use of this common communication profile. The device profiles describe the specific functionality of a device class or its parameters. For the most important device classes used in the industrial automation technology, such as digital and analog input/output modules, sensors, drives, operator panels, loop controllers, programmable control systems and encoders, suitable device profiles exist. Others are in preparation.

A central element of the CANopen standard is the description of the device functionality in an object directory.

The object directory is subdivided into a general part and a device-specific part. The general part contains details on the device, such as device identification, name of manufacturer, communication parameters etc. The device-specific part describes the specific functionality of the concerned device. These features of a CANopen device are described in a standardized Electronic Data Sheet (EDS).

A CANopen network consists of a maximum of 128 devices, one NMT master and a maximum of 127 NMT slaves. In contrast to other typical master-slave systems such as PROFIBUS, the CANopen terms Master and Slave have a different meaning.

In operational mode, all devices are able to transmit messages via the bus. In addition, the master can change the operating mode of the slaves.

Normally a CANopen master is realized by a PLC or a PC. The bus address of a CANopen slave can be set from 1 to 127. By the device address, a number of identifiers are created, which are then used by the device.

2.2.13.5 Location

The CANopen coupler is integrated in the housing of the basic unit. The bus interface is located on the top side to the left of the basic unit. There are also the 4 LEDs for displaying statuses.

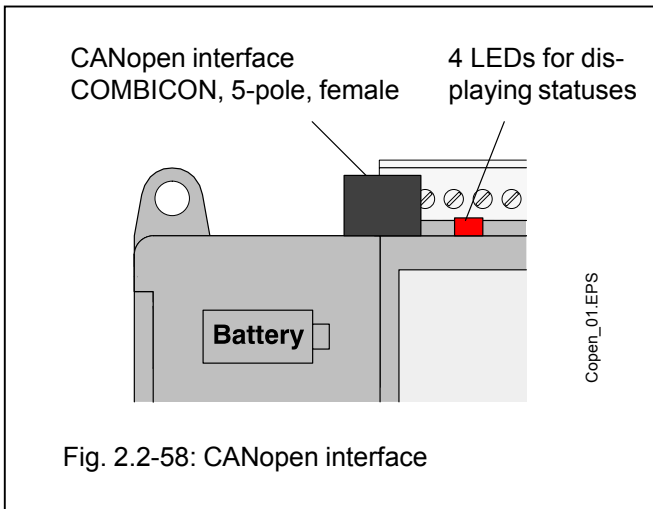

Fig. 2.2-58: CANopen interface

2.2.13.6 Pin assignment, meaning of the LEDs

The following figure shows the pin assignment of the CANopen interface as well as the names of the 4 LEDs. The drawing is shown looking from the front side (as mounted in the switch-gear cabinet).

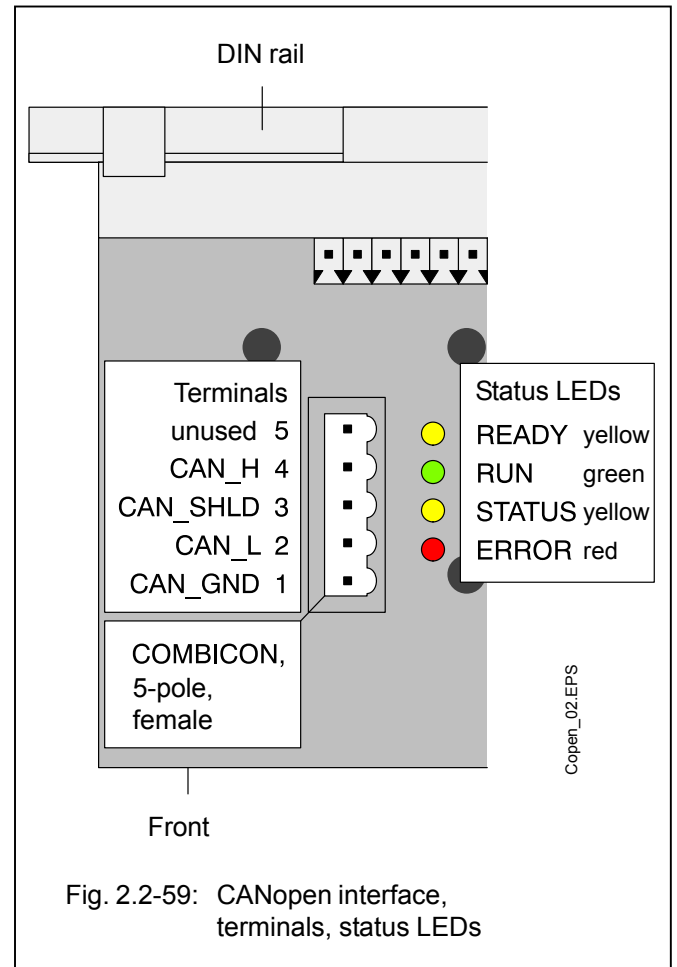

Fig. 2.2-59: CANopen interface, terminals, status LEDs

Terminal assignment (COMBICON, 5-pole, female)

Pin No.	Signal	Meaning
1	CAN_GND	CAN Ground
2	CAN_L	CAN_L bus line, Receive/Transmit low
3	CAN_SHLD	Shield of the bus cable
4	CAN_H	CAN_H bus line, Receive/Transmit high
5	unused	

Status LEDs

LED	Color	Condition	Meaning
READY	yellow	on flashes cyclic flashes non-cyclic off	Coupler ready Bootstrap loader active Hardware or system error Defective hardware
RUN	green	on flashes cyclic flashes non-cyclic off	Communication is running Communication is stalled Missing or faulty configuration No communication
STATUS	yellow	on off	Coupler transmits data Coupler does not transmit data
ERROR	red	on off	CANopen error No error

2.2.13.7 Bus termination

The data line ends must be equipped with 120-Ohm bus terminating resistors. Normally, the resistors are integrated in the interface connectors.

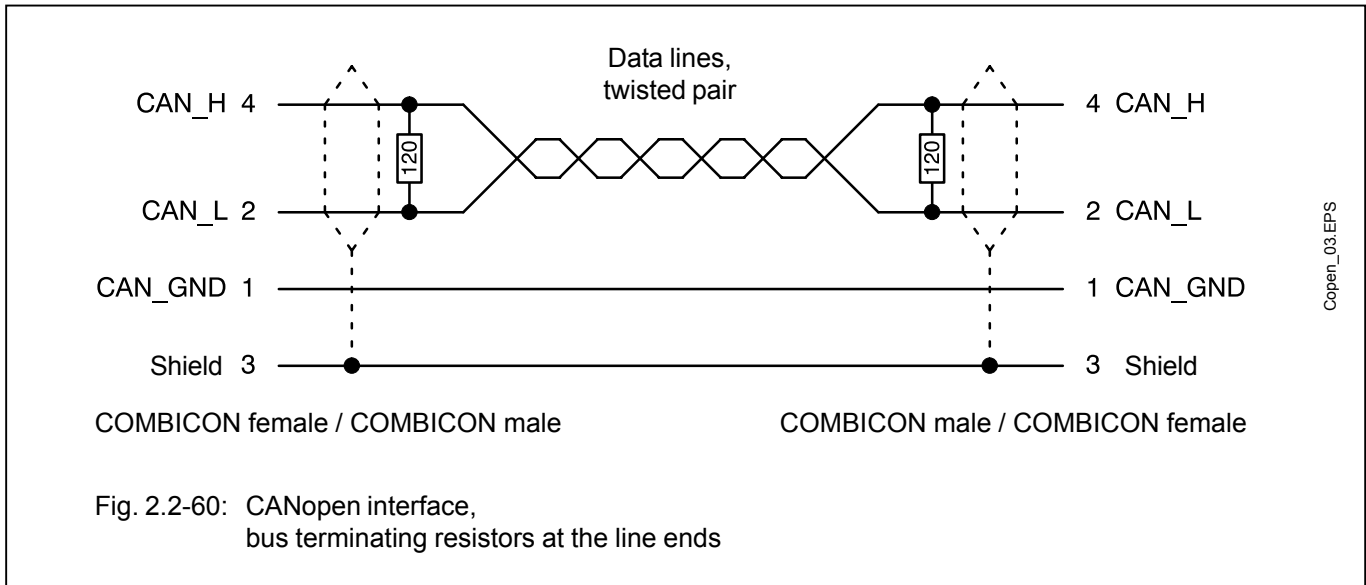

2.2.14 Description of the Ethernet coupler

2.2.14.1 Basic units with integrated Ethernet coupler

07 KT 98 R270 (Ethernet)	Order No. GJR5 2531 00 R0270
07 KT 98 R272 (Ethernet + PROFIBUS-DP)	Order No. GJR5 2531 00 R0272
07 KT 98 R276 (Ethernet + ARCNET)	Order No. GJR5 2531 00 R0276
07 KT 98 R277 (Ethernet + Ethernet)	Order No. GJR5 2531 00 R0277
07 KT 98 R278 (Ethernet + CANopen)	Order No. GJR5 2531 00 R0278

2.2.14.2 Technical data of the integrated coupler

Coupler type	Ethernet coupler in PC/104 format
Processor	EC1-160, system clock 48 MHz
Ethernet controller	EC1-160, internally
Interfaces	Ethernet Diagnosis
	10 / 100 BASE-TX / RJ45 MiniDIN, 8-pole, female
LED displays	RDY - System o.k. RUN - Configuration o.k. / Communication is running ERR - Communication error STA - Status of the Ethernet communication
Setting the station identifier	00 _H to FF _H
Internal supply with	+5 V, 300 mA
Dimensions	90 x 96 x 23 mm

2.2.14.3 Technical data of the software

Firmware	Protocol suite	UDP/IP TCP/IP Open MODBUS on TCP others in preparation
	EthernetIP	Slave only Cyclic and non-cyclic data transfer

2.2.14.4 Short description

The Ethernet coupler is an intelligent 100-Base-T-Ethernet communication interface based on the highly integrated microcontroller EC1. The coupler supports the complete TCP/IP protocol and the application layers, too.

The user interface is based on a dual-port memory.

The coupler meets the PC/104 standard. It is powered by the internal 5 V supply voltage.

The Ethernet communication is run via an RJ45 interface. In addition, the coupler has a diagnosis interface in Mini-DIN format.

The coupler is configured via the dual-port memory, the diagnosis interface or a TCP/IP connection by means of a system configurator. The configuration is saved non-volatile in a Flash EPROM.

2.2.14.5 Location

The following figure shows a basic unit with two Ethernet couplers, which are located on the bottom side to the left of the basic unit. Units which have only one coupler, use coupler No. 1.

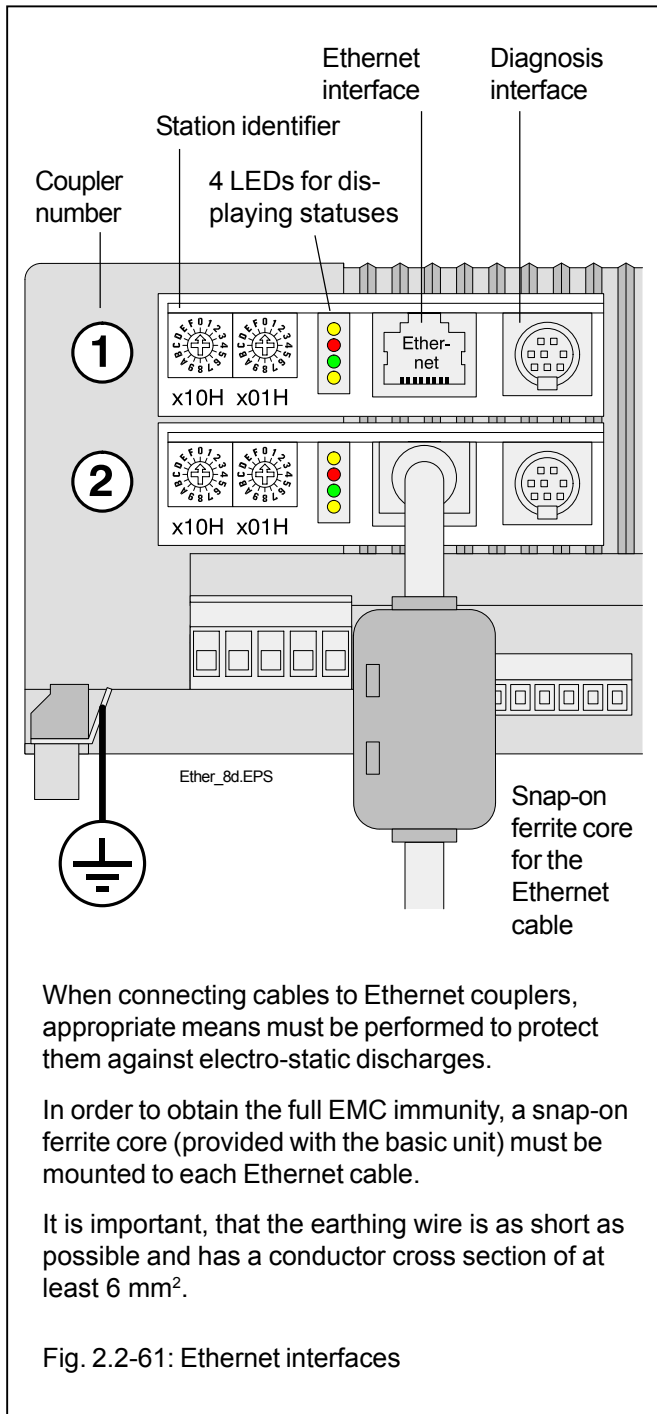

2.2.14.6 Station identifier

The following figure shows the setting of the station identifier.

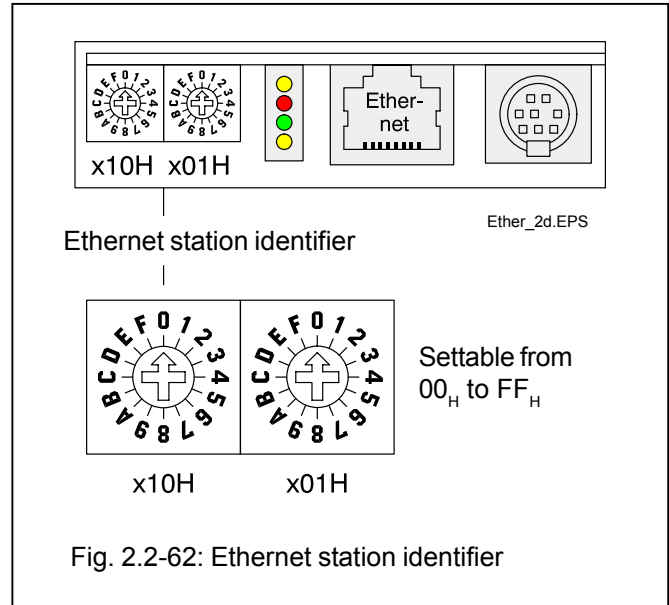

2.2.14.7 Ethernet interface

The following figure shows the Ethernet interface.

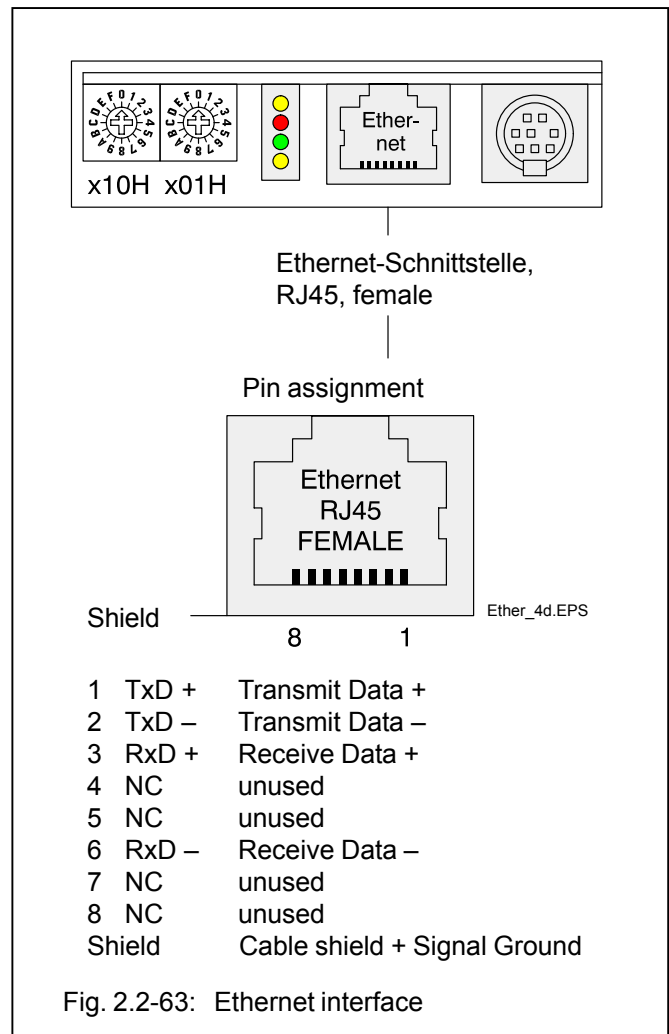

2.2.14.8 Diagnosis interface

The following figure shows the diagnosis interface.

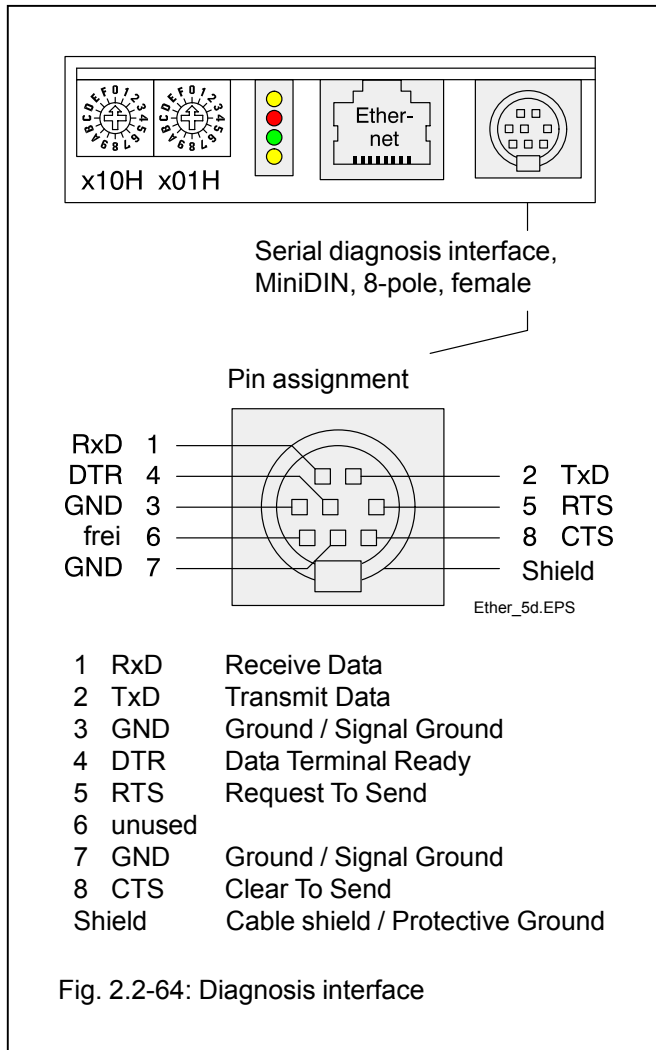

2.2.14.9 Meaning of the LEDs

The following figure shows the 4 status LEDs.

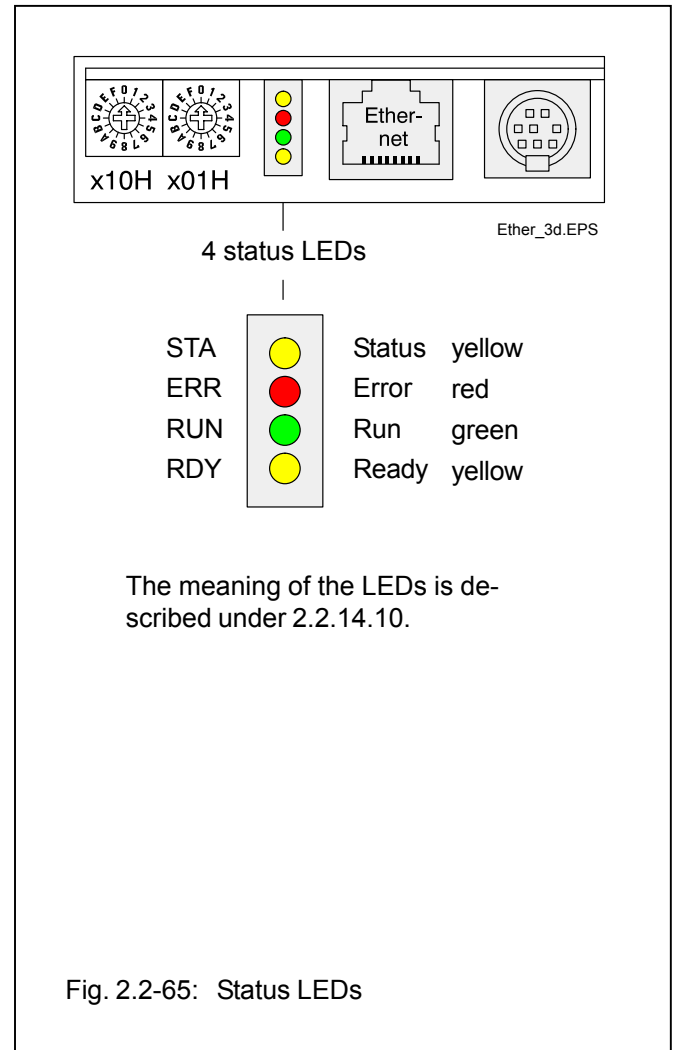

2.2.14.10 Status LEDs

LED	Color	Condition	Meaning
STATUS	yellow	flashes	Ethernet frame detected on the network
ERROR	red	on off	Error No error
RUN	green	eon flashes cyclic flashes non-cyclic off	Communication is running Ready for communication Parameterization error No communication
READY	yellow	on flashes cyclic flashes non-cyclic off	Coupler is ready Bootstrap loader is active Hardware or system error Defektive hardware



ABB STOTZ-KONTAKT GmbH

Eppelheimer Straße 82 Postfach 101680
69123 Heidelberg 69006 Heidelberg
Germany Germany

Telephone +49 6221 701-0
Telefax +49 6221 701-240
E-Mail desst.help@de.abb.com
Internet <http://www.abb.de/stotz-kontakt>