

GFK-0025A

FEBRUARY, 1988

Bus Controller with Diagnostics IC660CBB902 Bus Controller without Diagnostics IC660CBB903

a42187

- Interfaces Genius I/O serial bus to Series Six Plus programmable controller
- Provides channel selection for expanded I/O addressing
- Suitable for high-integrity system applications
- Available with or without diagnostics capabilities
- Supports CPU to CPU peer to peer communications
- Supports selectable baud rate

The Genius™ I/O system **Bus Controller** interfaces a Genius I/O serial bus to the Series Six™ PLC. The Bus Controller can be located in any Series Six High-capacity I/O slot or CPU rack.

One Bus Controller can support up to 31 Genius I/O devices on the serial bus. In a typical application, these devices are Genius I/O blocks and one or more Hand-held Monitors.

The Bus Controller can be used with either Normal I/O addressing, or Expanded addressing. If the system uses Expanded I/O addressing, a DIP switch on the Bus Controller can be used to enable channel selection.

The Bus Controller module is suitable for either standard I/O control applications, or high-integrity control systems. High integrity systems provide redundant operation with dual serial busses and/or dual CPUs on the same bus.

There are two types of Bus Controller, one that sends diagnostic reports to the CPU (Bus Controller IC660CBB902) and one that does not (Bus Controller IC660CBB903). Both send the CPU information about Bus Controller status and serial bus status. The Bus Controller with Diagnostics also sends diagnostic messages from the Genius I/O blocks on the serial bus. These messages indicate the block and individual I/O circuit faults. Once received by the CPU, diagnostic information is accessible to the ladder logic program. Diagnostic information from the CPU can be displayed on a CRT using the Logicmaster™ 6 or Alarm Master™ software.

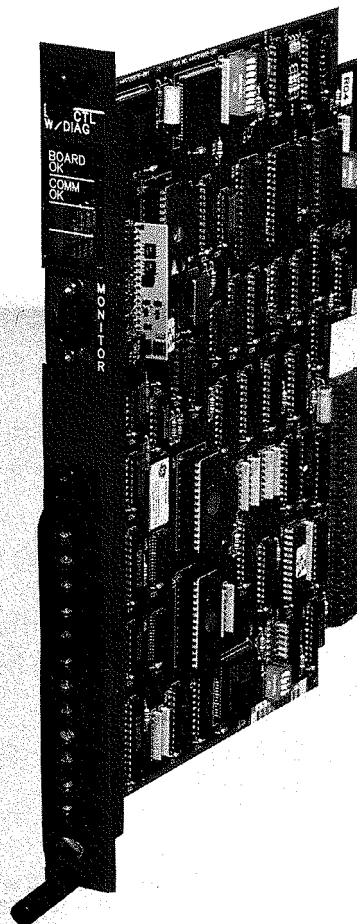

For applications requiring peer to peer information transfer, either Bus Controller can serve as a communications node, linking other devices - Bus Controllers, PCIMs, and other Genius devices - via the serial bus. Such a network can provide communications between multiple Series Six PLCs and host computers.

These communications include transmitting global register data from one CPU to another. The global data area is identified in the ladder logic program at startup. After initialization, the specified data area is transferred between devices automatically and repetitively.

In addition, messages called Datagrams can be transmitted in response to individual commands in the ladder logic. Datagrams can be sent from one device on the network to another, or broadcast to all devices on the bus.

BUS CONTROLLER OPERATION

Each Genius I/O serial bus conveys data by passing a "token" among the devices on the bus.

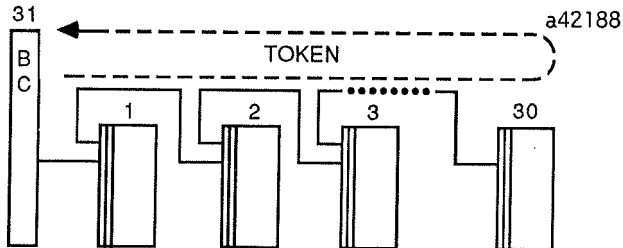

This cycle is called the bus scan. During the bus scan, the Bus Controller:

- Receives all inputs from the I/O blocks.
- A Bus Controller with Diagnostics also receives any faults and stores up to 60 in an internal fault table.
- Updates all outputs on the I/O blocks.
- Sends any command received from the CPU (for example, Clear Circuit Fault) to the appropriate device.

The Genius bus scan is independent of the Series Six CPU sweep.

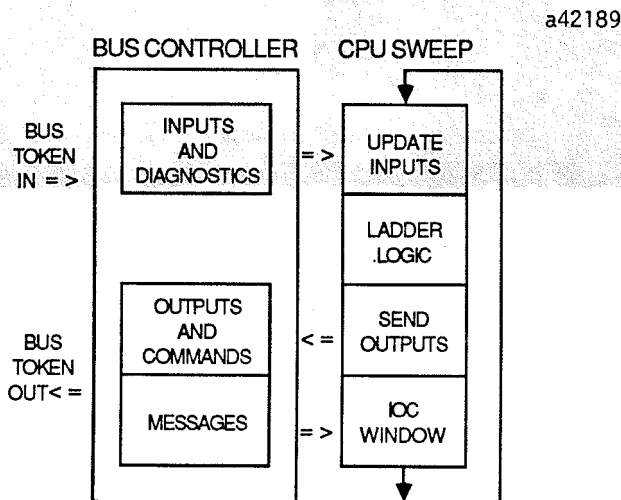

During the I/O service portions of the CPU sweep, the Bus Controller:

- Transfers all discrete inputs and one input value (16 bits) per analog block to the CPU Input Status Table.

- Receives current outputs and new commands from the CPU Output Status Table.
- Reports its status and that of the serial bus. A Bus Controller with Diagnostics also reports the status of the I/O blocks and provides any new diagnostics to the CPU. Diagnostics data is moved to the Input Table starting at the address set with the backplane DIP switches.

For a system with Expanded addressing, I/O and diagnostics data is also stored in the Register Table. For more information about Expanded addressing and channel selection, refer to *the Series Six Plus User's Manual*.

PERIPHERALS WINDOW

The Bus Controller can communicate with the CPU via the peripherals window using the commands:

1 Idle	8 Reserved
2 Read Configuration	9 Read Status Table Address
3 Write Configuration	10 Reserved
4 Read Diagnostics	11 Switch BSM
5 Reserved	12 Send Datagram
6 Reserved	13 Receive Datagram
7 Read analog data	

LADDER LOGIC FOR THE BUS CONTROLLER

No additional ladder logic is needed to use the Bus Controller. However, optional ladder logic for the Bus Controller might include:

- A DPREQ to update all analog inputs during one CPU sweep.
- A data move instruction to capture diagnostic data from the Bus Controller I/O status references.
- A DPREQ to specify communications between devices on the bus.
- A DPREQ with a Write Configuration command to the Bus Controller to enable or disable outputs on a block by block basis.

The DPREQ instruction is for systems using Normal (non-expanded) addressing. For a system with Expanded addressing, the WINDOW instruction is used instead.

GFK-0025

INSTALLING THE BUS CONTROLLER

Before installing the Bus Controller, system configuration should be properly planned. See the *Genius I/O System User's Manual*. To install a Bus Controller, you must:

1. Set the DIP switches and jumpers on the Bus Controller
2. Set the I/O reference DIP switch at rear of rack
3. Insert the Bus Controller in the rack
4. Attach the serial bus wires
5. Power up I/O rack and/or CPU.

STEP 1. SET THE SWITCHES AND JUMPERS ON THE BUS CONTROLLER

Before inserting the Bus Controller in the rack, set these DIP switches and jumpers:

- a. Option Selection Switches (required)
- b. Impedance Selection Jumpers (required)
- c. Channel Selection Switches (optional - for Expanded I/O addressing only)
- d. Output Disable Switches (optional - to disable all outputs at powerup)

Step 1a. Set the Option Selection Switches:

Following the instructions below, set the switches on the Option Selection Switch pack at position U3, top center of the board.

a42190

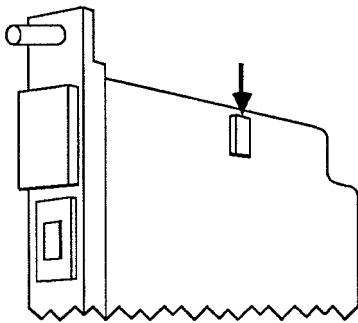

Setting the CPU Shutdown Mode Switch: Set switch 1 to determine what will happen to the CPU sweep should the Bus Controller self-test fail.

Open = CPU sweep will continue if Bus Controller self-test fails.

Closed = CPU sweep will stop if Bus Controller self-test fails.

Setting the Bus Controller Baud Rate: Set switches 2 and 3 to select the baud rate for the Bus Controller. 153.6K baud extended provides data communications at 153.6K baud with delays between messages, allowing the use of longer bus cables.

SWITCH	BAUD RATE (Kbaud)			
	153.6 standard	76.8	38.4	153.6 extended
2	x	x		
3	x		x	

x = open/off (switch in left position)

Note: Select the same baud rate for the Bus Controller as that used for other devices on the bus. *The bus will not operate unless all devices are set to the same baud rate.*

Setting the Device Number: Set switches 4 through 8 to select a Device Number (from 0-31) for the Bus Controller. The Device Number is its address on the serial bus. Be sure the Device Number set is not used for any other device on the bus. If there is just one Bus Controller on the bus, Device Number 31 is typically used. For redundant systems, the Bus Controllers must be set to Device Number 30 or 31. When shipped from the factory, Device Number is 31.

SWITCH	DEVICE NUMBER								
	111111111122222222233 01234567890123456789012345678901								
4									xxxxxxxxxxxxxxxx
5									xxxxxxx xxxxxxxx
6									xxxx xxxx xxxx xxxx
7									xx xx xx xx xx xx xx xx
8									x x x x x x x x x x x x x x x x

x = open/off (switch in left position)

Step 1b. Set the Impedance Selection Jumpers

a42192

The serial bus must be terminated at each end by its characteristic impedance. If the Bus Controller is at the end of the bus, select the correct impedance for the cable length and type, as shown in table 1. If the Bus Controller is not at the end of the bus, select no impedance.

Use jumpers JP1 through JP3, centered at the left side of the module, to select impedance.

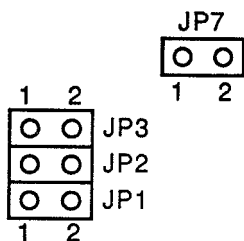

a42191

When the Bus Controller is shipped, a jumper across JP7 selects no impedance. To select an impedance value, move the jumper from JP7 to another position:

- 75Ω : move jumper to JP1
- 100Ω : move jumper to JP2
- 150Ω : move jumper to JP3
- JP4-JP6 are not used

Step 1c. Set the Channel Selection Switches

If the PLC system uses Expanded I/O addressing, the I/O channel used by the devices on the serial bus may be selected by either an I/O Transmitter module or the Bus Controller. The switches in the 4-position DIP switch located at the lower right of the module (position U59) enable Expanded I/O addressing, and specify the channel number.

Switch 4 selects Expanded addressing. If an I/O Transmitter card is being used to select channelization, set switch 4 to CLOSED. If Expanded addressing will be selected by the Bus Controller, set switch 4 to OPEN. Then, select the I/O channel number using switches 1 through 3. *To address a channel in the auxiliary chain, the Bus Controller must be installed downstream of an Auxiliary I/O Module.*

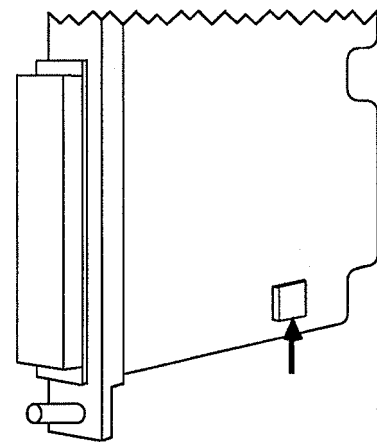

SWITCH	CHANNEL NUMBER (0-F)															
	Main Chain							Aux Chain								
	0	1	2	3	4	5	6	7	AI	9	A	B	C	D	E	F
1		x	x		x	x				x	x		x	x		
2			x	x			x	x			x	x			x	x
3					x	x	x	x					x	x	x	x

x = open/off (switch in left position)

Step 1d. Set the Outputs Disable Switch

The 4-segment DIP switch located at the upper right of the module (position U16) is used to either enable or disable all output circuits on the serial bus following powerup of the Bus Controller. Switches 1-3 must be OPEN. If switch 4 is set to OPEN, outputs on a block are enabled only if the corresponding Disable Outputs bit is subsequently reset from the ladder logic (using a DPREQ to perform a Write Configuration to the Bus Controller.)

a42193

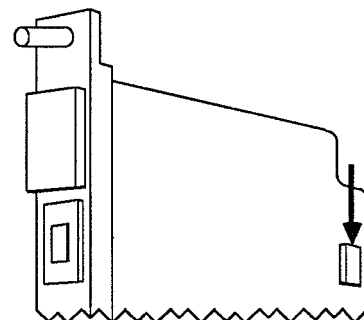

STEP 3. INSERT THE BUS CONTROLLER

After setting board options, install the Bus Controller in the rack by following these steps:

1. Position the Bus Controller to the left of the Reference Selection DIP switches you set. Using the board remover/installer, press the board carefully into the connector until it is securely lodged.

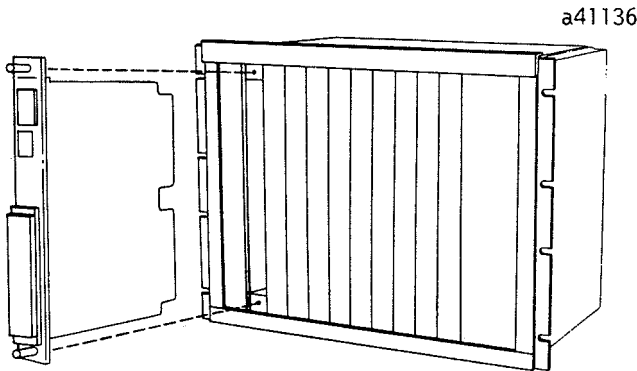

2. Position the faceplate over the Bus Controller and tighten the screws.

STEP 4. WIRE THE SERIAL BUS

Using shielded, twisted pair cable, create a serial bus connecting the Bus Controller, I/O blocks, and other permanently-installed devices.

Cable used for one serial bus must all be the same, or the bus will not work. Other buses connected to the same CPU may use different types of cable (unless joined by a Bus Switching Module, as described on the next page). Cable specifications are listed below. For applications using Belden 9182 type cable, prefabricated cables are available in 15-inch and 3-foot lengths. See the Ordering Information on page 8.

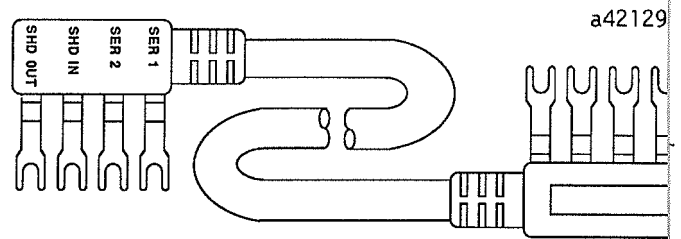

Connect the Serial 1 terminals of adjacent devices together and the Serial 2 terminals of adjacent devices together. Connect each Shield In terminal to the Shield Out terminal of the previous device.

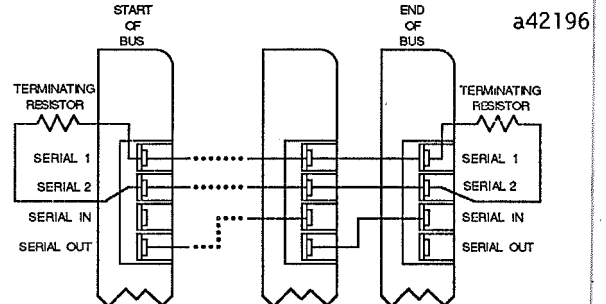

Cable # & Make	Outer Diameter	Terminating Resistor* -10%to+20% ½ Watt	Installation	Number of Conductors/AWG	Di-Electric Voltage Rating	Ambient Temp Rating	Maximum Length Cable Run, feet/meters at baud rate			
							153.6s	153.6e	76.8	38.4
(B)9182 (A)9B23 (C)4596	.350in 8.89mm	150 ohms	In conduit	2 / #22	30v	60°C	2000ft 606m	3500ft 1061m	4500ft 1364m	7500ft 2283m●
(B)89128	.322in 8.18mm	150 ohms	In plenum No conduit	2 / #22	150v	200°C	2000ft 606m	3500ft 1061m	4500ft 1364m	7500ft 2283m●
(B)9841	.270in 6.86mm	120 ohms*	Double Shields In Conduit	2 / #24	30v	80°C	1000ft 303m	1500ft 455m	2500ft 758m	3500ft 1061m●
(B)9207	.330in 8.38mm	100 ohms	In Conduit	2 / #20	300v	80°C	1500ft 455m	2500ft 758m	3500ft 1061m	6000ft 1818m●
(B)89207 (A)4794	.282in 7.16mm	100 ohms	In plenum No conduit	2 / #20	150v	200°C	1500ft 455m	2500ft 758m	3500ft 1061m	6000ft 1818m●
(B)9815	.330in 8.38mm	100 ohms	Direct Burial	2 / #20			1500ft 455m	2500ft 758m	3500ft 1061m	6000ft 1818m●
(B)9855	.315in 8.00mm	100 ohms	In Conduit	4 (two pair) #22	150v	60°C	1200ft 364m	1700ft 516m	3000ft 909m	4500ft 1364m●
(B)89696 (B)89855	.274in 6.96mm	100 ohms	In plenum No Conduit fire resist	4 (two pair) #22	150v	200°C	1200ft 364m	1700ft 516m	3000ft 909m	4500ft 1364m●
(B)9463 (A)9814	.243in 6.17mm	75 ohms	In Conduit	2 / #20	150v	60°C	800ft 242m	1500ft 455m	2500ft 758m	3500ft 1061m
(B)9302	.244in 6.20mm	75 ohms	In Conduit	4 (two pair) #22	300v	80°C	200ft 30m	500ft 152m	1200ft 333m	2500ft 758m

Notes: A = Alpha, B = Belden, C = Consolidated
 ● Limited to 16 taps at maximum length and 38.4 K baud.
 * For the Bus Controller, use on-board jumper to select 150 ohms.

GFK-0025

Terminate each end of the bus with its characteristic impedance, as listed in the table on the previous page. If the Bus Controller completes one end of the serial bus, impedance is set on the board (see page 4). For other bus termination, prefabricated plugs are available.

a42130

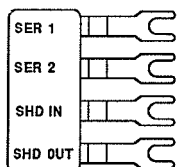

Dual Serial Busses with a BSM

For some applications, a dual serial bus may be used to provide a backup communications path. Bus Switching Modules (BSMs) connect bus stubs containing a few Genius I/O blocks with two serial busses, each with its own Bus Controller(s) or PCIM module(s). Blocks on a stub are connected using short lengths of unterminated cable.

a42360

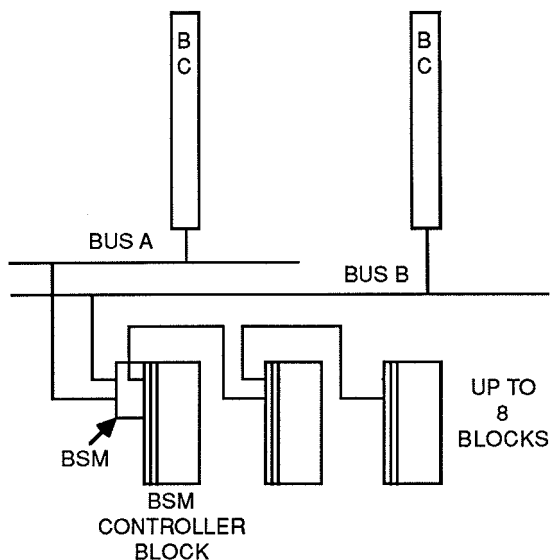

In a dual bus system, cable length and block placement should be planned well. Before installing blocks or cabling for a system using BSMs, read the *Bus Switching Module data sheet* (GFK-0072).

CHECKING THE BUS CONTROLLER LEDS

After powering up the rack, check the status of the Bus Controller LEDS:

BOARD OK	COMM OK	Meaning
ON	ON	Bus Controller functioning Bus communications OK
ON	OFF	Bus Controller functioning No Bus communications
ON	Blinking	Bus Controller functioning Bus communication error
Synchronous blinking		No Bus communications, Device Number Conflict
OFF	Don't care	Bus Controller failure

If both LEDS do not light, check the following:

If BOARD OK is off and COMM OK is on:

1. Be sure the board is in the correct slot.
2. Be sure reference selection DIP switches are set for address below 1000.

If BOARD OK is on and COMM OK is off:

1. Check for correct cable type and length.
2. Check for correct terminating impedance at both ends of bus.
3. Be sure the cable is daisy-chained.
4. Check for switched Serial 1 and Serial 2 wires.
5. Look for broken cable.
6. Determine if another Bus Controller has been given the same reference number.

If both LEDS are off:

1. Be sure the board is seated properly, and is receiving power.
2. Be sure the board is located in a High Capacity rack.

MONITORING BUS STATUS

To display serial bus status, set the Hand held Monitor to Monitor mode. From the Block/Bus Status screen, press F4 (Bus).

S	E	R	I	A	L	B	U	S	S	T	A	T	S
A	C	T	V	D	E	V	I	C	E	S	=		
S	C	A	N	T	I	M	E	=			m	S	
B	U	S	C	N	T	R	L	#	=				

BUS CONTROLLER SPECIFICATIONS**Operational:**

Form Factor	Standard Series Six™ PLC module, can be installed in CPU Rack or High-capacity I/O Rack
Power Requirements	Draws 20 units of load (one unit = 300mW) at +5 volts and 2 units of load at +12 volts
Size	11.0"(280mm) H x 1.2"(31mm) W x 8.15"(208mm) D
Weight	2.4 lbs (1.1 Kg)
LEDs	Board OK, Comm OK
Number of Bus Devices	Up to 32
Bus Type	Shielded, twisted pair cable
Isolation	1500 volts between devices on the bus
Baud Rates	153.6K baud standard, 153.6K baud extended, 76.8K baud, 38.4K baud
Bus Length	Up to 2000 feet (606 meters) at 153.6K baud, up to 7500 feet (2283 meters) at 38.4K baud
Bus Scan Time	3 ms minimum, including 1 ms overhead 10 ms typical, 400 ms maximum
Communications	Transmit Global Data from registers for peer-to-peer communication Transmit Datagram and Transmit Datagram with Reply Read Device and Write Device from device on serial bus to Series Six CPU

Environmental:

Operating Temperature	0°C to +60° C (32°F to 140°F)
Storage Temperature	-25°C to +60° C (-13°F to +140°F)
Humidity	5% to 95% (non-condensing)

ORDERING INFORMATION

Description	Catalog Number
Bus Controller with Diagnostics Board and Faceplate	IC660CBB902
Bus Controller without Diagnostics Board and Faceplate	IC660CBB903
Communications Cable (Belden 9182 type) 15-inch, quantity 3	IC660BLC001
3-foot, quantity 1	IC660BLC003
Bus Terminating Plugs 150 Ohm, quantity 4	IC660BLM506
75 Ohm, quantity 4	IC660BLM508

GE FANUC AUTOMATION NORTH AMERICA, INC., CHARLOTTESVILLE, VIRGINIA