

Safety Manager
Hardware Reference

EP-SM.MAN.6284

Issue 1.0

20 February 2013

Release 151

The table below gives an example per group of modules. For each example module element the module name and function is given.

All groups of modules	Example module element	Module name and function
Chassis	CPCHAS-0002	Chassis for redundant Controller (Safety Manager A.R.T.)
Power supplies	PSU-UNI2450U	25—28 Vdc Power supply (1200 W) – UL508 approved
Control Processor modules	QPP-0002	Quad Processor Pack
	Note: The Power Supply module within this group is the exception to the rule. Naming of this module will be in line with the naming convention for Power supplies.	
Input modules	SDI-1624	Safe digital input module (24 Vdc, 16 channels)
Input converter modules	BSN-1608	Digital converter module for Safety sensor signals (16 channels)
Output modules	SDOL-0424	Safe loop-monitored digital output module (24 Vdc, 1 A, 4 channels)
Output converter modules	BSDOL-04UNI	Range setting module
Universal IO modules	RUSIO-3224	Remote Universal Safe IO device (32 channels, 24 Vdc)
IO busses	FS-IOBUS-CPIOX	IO bus in extension cabinet
FTAs for standard functions	TSAI-1620M	Safe 0-20 mA and 4-20 mA analog input FTA (16 channels)
FTAs for special functions	TSHART-1620M	Safe 0-20 mA and 4-20 mA analog input FTA with HART interface (16 channels)
FTAs for communication purposes	DCOM-232/485	RS232/485 communication FTA
IOTAs for remote applications	IOTA-R24	Redundant IO Termination Assembly
Field Terminal Solutions	TERM-NAMUR-01	NAMUR to 0-20mA analog-IN converter terminal
System Interconnection Cables	SICC-0001/L50	System Interconnection Cable terminating on FTAs (SICC)
Communication Cables	CCE-485-05/L10	External communication cable
Power distribution	PDB-0824P	Power Distribution Board (24Vdc, 2 Amp, 8 channel)
5V and watchdog distribution	PDC-CPX05	Power Distribution Board Controller cabinet (5 Vdc, Watchdog)

Field Termination Assembly modules

15

This chapter describes the field termination assembly modules that are available for Safety Manager.

The following Field Termination Assembly (FTA) modules are described:

FTA		see
Input FTAs		
TSDI-1624	Safe digital input FTA (24 Vdc, 16 channels)	page 505
TSDI-1648	Safe digital input FTA (48 Vdc, 16 channels)	page 509
TSDI-16UNI	Safe digital input FTA (24/48 Vdc, NAMUR, 16 channels)	page 513
TSDI-1624C	Safe current-limited digital input FTA (24 Vdc, 16 channels)	page 516
TSDI-16115	Safe active/passive digital input FTA (115 Vac/dc, 16 channels)	page 519
TIDI-1624	Non-safe Isolated passive digital input FTA (16 channels)	page 528
TSAI-0410	Safe analog input FTA (4 channels)	page 532
TSAI-1620m	Safe 0-20 mA and 4-20 mA analog input FTA (16 channels)	page 535
TSHART-1620m	Safe 0-20 mA and 4-20 mA analog input FTA with HART interface (16 channels)	page 543
TSGAS-1624	Safe gas / flame detector input FTA (0-20 mA, 16 channels)	page 552
TSGASH-1624	Safe gas/flame detector input FTA with HART interface (0-20 mA, 16 channels)	page 557
TSGASH-1624P	Safe gas/flame detector input FTA with HART interface (0-20 mA, 16 channels)	page 563
TSFIRE-1624	Safe fire detector input FTA with line monitoring (24 Vdc, 16 channels)	page 569
Output FTAs		
TSDO-0824	Safe digital output FTA (24 Vdc, 8 channels)	page 575
TSDO-0824C	Conformal coated safe digital output FTA, current limited (24 Vdc, 8 channels)	page 578
TDOL-0724	Line-monitored relay contact digital output (7 channels, 24Vdc)	page 582

Specific FTAs can only be used with particular IO or IO converter modules. Table 72 on page 502 shows possible FTA - IO module combinations and Table 73 on page 503 shows possible FTA-CP module combinations.

Table 72 possible FTA - IO module combinations

FTA module	Input module	Output module	Remarks
TSDI-1624	SDI-1624		
TSDI-1648	SDI-1648		
TSDI-16UNI	SDIL-1608 SDI-1624 SDI-1648		
TSDI-1624C	SDI-1624		
TSDI-16115	SDI-1624		
TIDI-1624	SDI-1624		
TSAI-0410	SAI-0410		
TSAI-1620m	SAI-1620m		
TSHART-1620m	SAI-1620m		with HART connection
TSGAS-1624	SAI-1620m		
TSGASH-1624	SAI-1620m		with HART connection
TSGASH-1624P	SAI-1620m		with HART connection
TSFIRE-1624	SAI-1620m		
TSDO-0824		SDO-0824	
TSDO-0824C		SDO-0824	
TDOL-0724	SDI-1624	SDO-0824	both modules are required
TDOL-0724P	SDI-1624	SDO-0824	both modules are required

TSHART-1620m

Safe 0-20 mA and 4-20 mA analog input FTA with HART interface (16 channels)

Description

Field termination assembly module TSHART-1620m is the interface between field components (sensors, etc.) and the safe high-density analog input module SAI-1620m in Safety Manager. The FTA provides HART interface. It can be used for interfacing signals from Class I, division 2 Hazardous Locations.

The TSHART-1620m module has sixteen analog input channels, which may be used for both safety-related and non-safety-related applications. These sixteen channels (separated into two groups of eight channels with common 0 V) are connected via a system interconnection cable (SICC-0001/Lx), which is plugged into the SIC connector on the FTA module, and connects to a (redundant pair of) SAI-1620m module(s).

The FTA module has a universal snap-in provision for standard DIN EN rails, and screw terminals for connection of power supply, ground and field wiring.

Figure 326 Mechanical layout

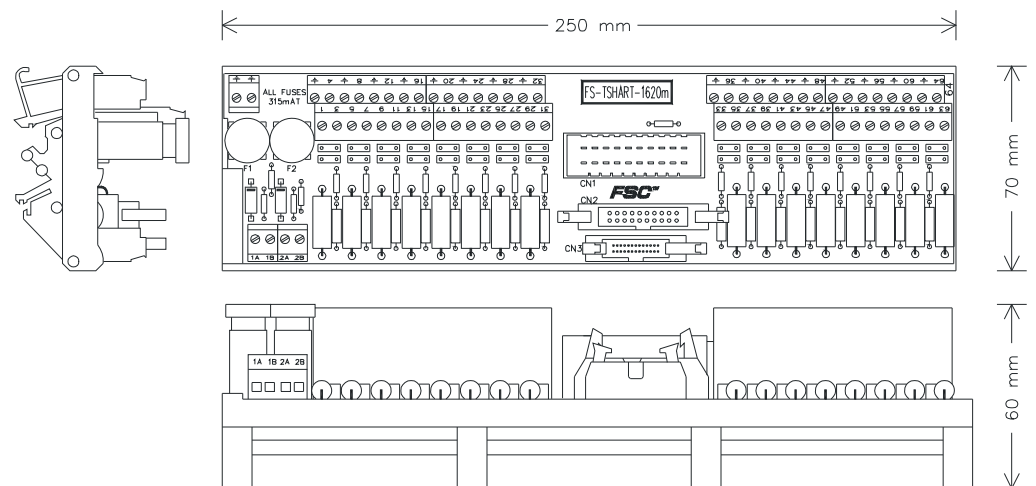

Main functions

The TSHART-1620m module has four main functions:

- Linear direct conversion of 0(4)—20 mA DC field signals to the signal levels of the safe high-density analog input module SAI-1620m
- Enable connection to HART multiplex units of MTL or Pepperl+Fuchs (P+F)
- Power supply distribution to each transmitter with voltage-current limitation in compliance with Hazardous Area Class I Division 2
- Enable monitoring of the external power connected to the FTA module

Linear direct conversion

The input circuit of each channel consists of a high-precision resistor, which converts the input current (0—20 mA) to the input voltage for the high-density analog input module SAI-1620m. The power to the analog transmitter is supplied via a series resistor. Each analog signal has its own terminal for the field cable shield. Figure 327 on page 545 shows the schematic diagram for connecting a transmitter (active and passive).

Figure 327 Schematic diagram for connecting a transmitter

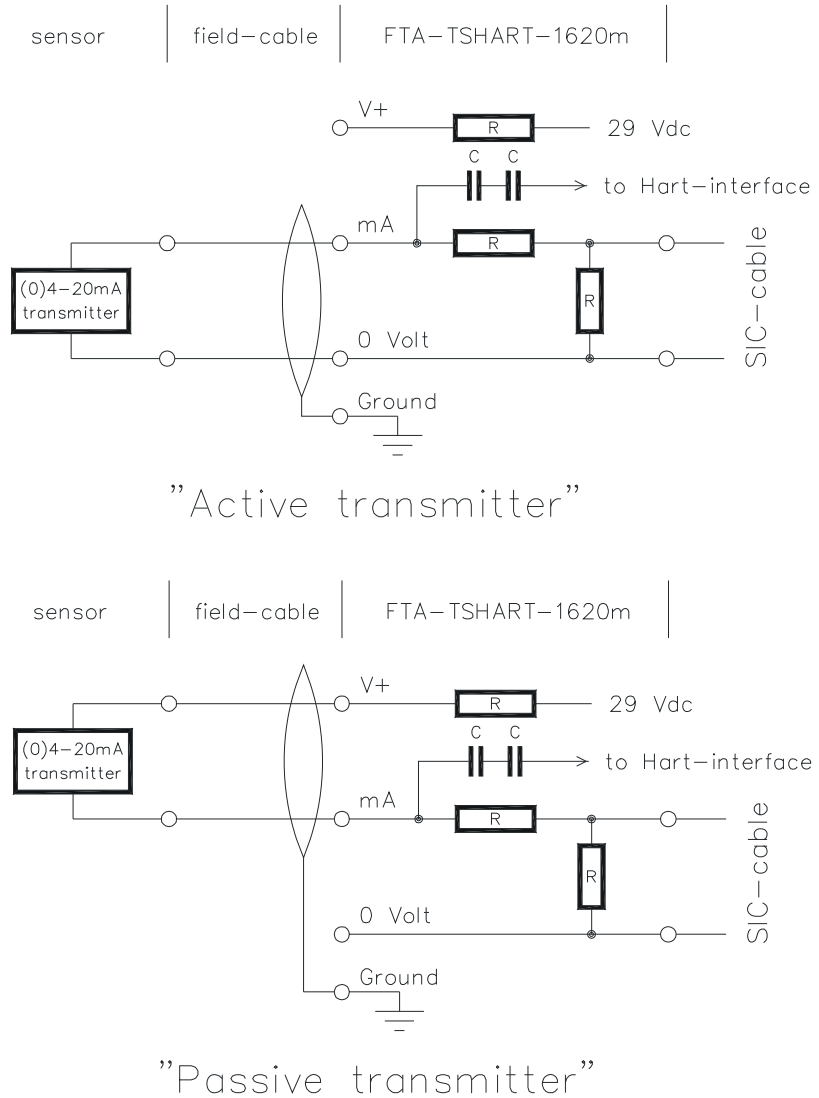

HART interface



Warning:

Suggested HART multiplexers have *no* galvanic isolation between (24 Vdc) supply and the HART signals (common 0 Vdc).

The TSHART-1620m module provides an interface to HART multiplex units from MTL and P+F. Special connectors are installed on the FTA for connection of the standard cables from these suppliers.

The following connections and equipment can be used:

MTL solution:

- Multiplex unit MTL4842
- Cable: MTL FLAT20-2.2
- Connector on FTA: CN2 (see Figure 326 on page 543)

P+F solution:

- Multiplex unit KFD0-HMS-16 or KFD2-HMM-16
- Cable: K-HM26
- Connector on FTA: CN3 (see Figure 326 on page 543)

Class I division 2

The TSHART-1620m module may be used for non-incendiary field circuits to Class I, division 2 applications. The external output voltage (V+) is current-limited by means of a series resistor.

Transmitter voltage

Figure 328 on page 546 shows the available transmitter voltage for passive transmitters.

Figure 328 Transmitter voltage for passive transmitters

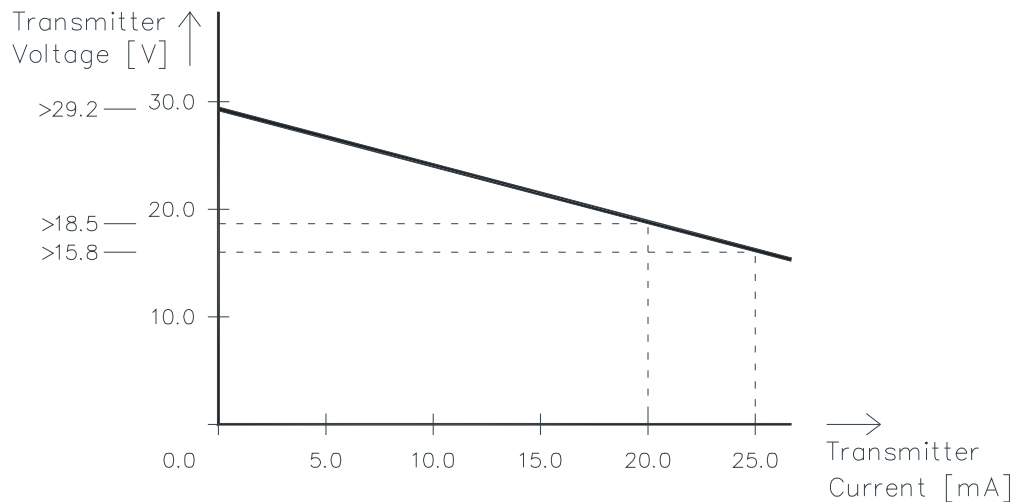

External power

If all inputs are active, no external power is required.

For loops, which contain passive transmitters, analog process data is only available if the supply voltage to the electronics is guaranteed. The high-density analog input concept (using TSHART-1620m / TPSU-2430 modules) offers full monitoring of power that is provided externally. If DC/DC converter modules TPSU-2430 are used, even redundant power supplies are covered.

Redundant external power can be connected to the TSHART-1620m module via two screw terminal pairs marked '1A', '1B', '2A' and '2B'. The screw terminal pairs are interconnected on the FTA module but de-coupled via diodes. The sixteen channels on the FTA module are divided into two groups of eight channels, with each group being protected by a 315 mA fuse. Single-channel errors (shorts from V+ to 0 V) cannot blow the group fuse.



Note

The 0 V connection of the external power is directly connected to the common 0 V of all sixteen analog inputs.

The Safety Manager application software must monitor the external power voltage via the safe high-density analog input module SAI-1620m when safety-related analog input signals are connected to the TSHART-1620m.

Figure 329 on page 547 shows the schematic diagram for power distribution with monitoring.

Figure 329 Schematic diagram for power distribution with monitoring

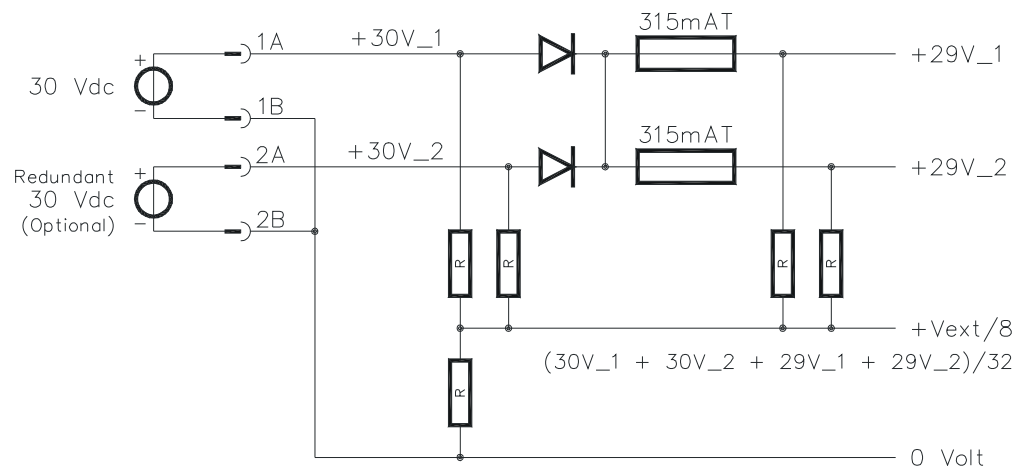

Applications

For details on applications and connection options for the TSHART-1620m module see “SICC-0001/Lx” on page 715.

Connections

External power and ground

The redundant external supply voltage (V_{ext}) and ground are connected to the following screw terminals (marked ‘1A’, ‘1B’, ‘2A’, ‘2B’ and ‘⬇’ on the FTA):

Screw terminal	Function
1A	30 Vdc V_{ext} feeder 1
1B	0 Vdc V_{ext} feeder 1
2A	30 Vdc V_{ext} feeder 2
2B	0 Vdc V_{ext} feeder 2
⬇	Ground connection
⬇	Ground connection (1 ground wire is enough)

Connections diagram

Figure 330 on page 549 shows the connections diagram of the TSHART-1620m module.

The TSHART-1620m module has sixteen groups (= sixteen channels) of four screw terminals to provide optimum connection of field wiring, with a ground terminal per channel for screening of analog input cables. The screw terminals are numbered 1 to 64.

Figure 330 Connections diagram

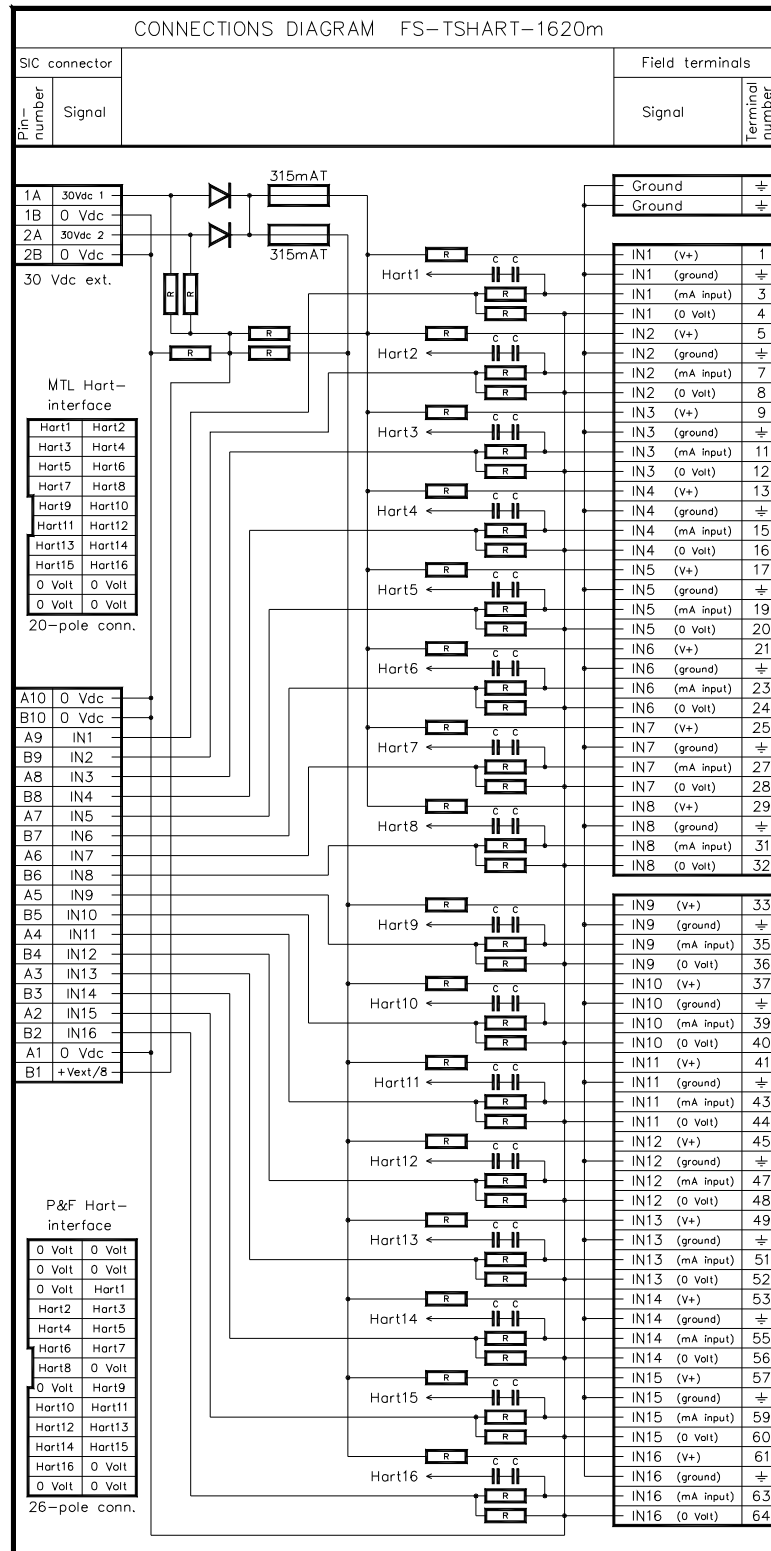

Technical data

The TSHART-1620m module has the following general specifications:

General	Type numbers ¹ :	FS-TSHART-1620m
		FC-TSHART-1620m
	Approvals:	CE, TUV, UL, CSA, FM
Input	Number of input channels:	16 (2 groups of 8 with common 0 V)
	Power requirements:	30 Vdc external, 3 mA (without input loop loads)
	Input current:	0—25 mA
	Input resistance:	250 Ω (\pm 1%)
Output	To passive transmitters (Vext):	
	• Output resistance:	270 Ω (\pm 5%)
	• Igniting current per channel:	< 120 mA at 30 Vdc
	To SAI-1620m module:	
	• Output voltage	0—4 Vdc
	• Accuracy	0.1%
	To HART multiplex unit:	
	• Output voltage	Max. 5 V peak-peak
	• Series impedance	> 100 nF
Fuses	Rating:	315 mAT (slow-acting)
	Dimensions:	5 × 20 mm (0.20 × 0.79 in)
Physical	Module dimensions:	250 × 70 × 60 mm (L × W × H) 9.84 × 2.76 × 2.36 in (L × W × H)
	DIN EN rails:	TS32 / TS35 × 7.5
	Used rail length:	251 mm (9.87 in)
Termination	Screw terminals:	
	• Max. wire diameter	2.5 mm ² (AWG 14)
	• Strip length	7 mm (0.28 in)
	• Tightening torque	0.5 Nm (0.37 ft-lb)

1 FS-type modules are non conformal coated modules.
FC-type modules are conformal coated modules. Conformal coated modules have the letters "CC" preceding the version number.

The TSHART-1620m module has the following specifications for non-incendive field circuits, Class1 Division 2:

Field signal specifications for non-incendive field circuits, Class1 Division 2	HYDROGEN (Group A & B):	
	• Max. loop inductance	6 mH
	• Max. loop capacitance	0.25 μ F
	NON-HYDROGEN (Group C & D):	
	• Max. loop inductance	20 mH
	• Max. loop capacitance	5 μ F